

INHIBITOR SWITCH

AUTOMATIC TRANSMISSION

13. Inhibitor Switch

A: INSPECTION

When the driving condition or starter motor operation is erroneous, first check the shift linkage for improper operation. If the shift linkage is functioning properly, check the inhibitor switch.

- 1) Disconnect the inhibitor switch connector.
- 2) Check continuity in inhibitor switch circuits with the select lever moved to each position.

NOTE:

- Also check that continuity in ignition circuit does not exist when the select lever is in "R", "D", "3", "2" and "1" ranges.
- If the inhibitor switch is inoperative, check for poor contact of connector on transmission side.

	Position	Pin No.
Signal sent to TCM	P	4 — 3
	R	4 — 2
	N	4 — 1
	D	4 — 8
	3	4 — 7
	2	4 — 6
	1	4 — 5
Ignition circuit	P/N	12 — 11
Back-up light circuit	R	10 — 9

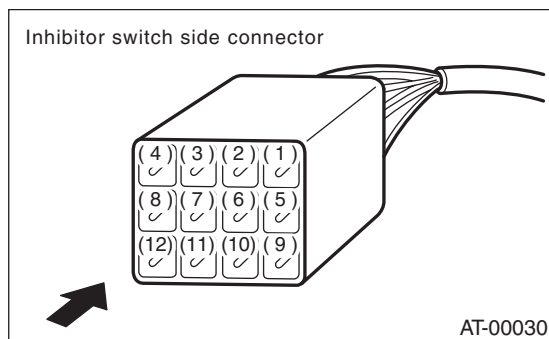

3) Check if there is continuity at equal points when the select lever is turned 1.5° in both directions from "N" range.

If there is continuity in one direction and the continuity in the other or if there is continuity at unequal points, adjust the inhibitor switch. <Ref. to 4AT-50, ADJUSTMENT.>

Except model with SPORTS shift

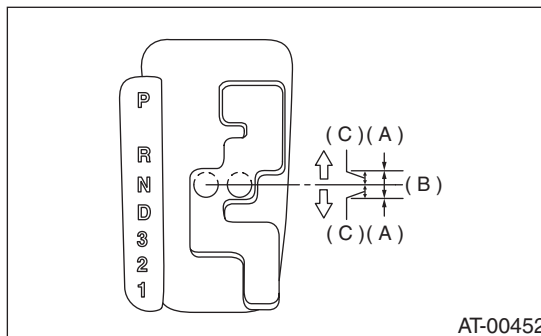

- (A) Continuity does not exist.
- (B) Continuity exists.
- (C) 1.5°

Model with SPORT shift

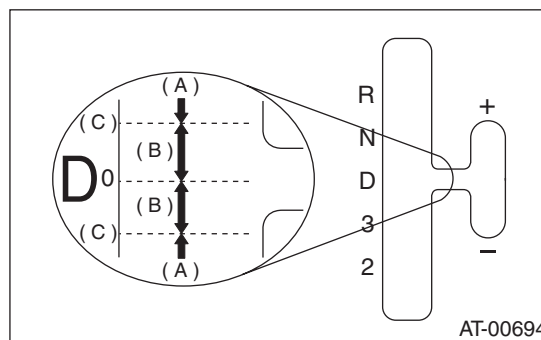

- (A) Continuity does not exist.
- (B) Continuity exists.
- (C) 1.5°

4) Repeat the above checks. If there are abnormalities, adjust the select cable. <Ref. to CS-32, ADJUSTMENT, Select Cable.>

B: ADJUSTMENT

- 1) Shift the select lever to "N" range.
 - 2) Loosen the three inhibitor switch securing bolts.
 - 3) Insert the ST as vertical as possible into the holes in inhibitor switch lever and switch body.
- ST 499267300 STOPPER PIN

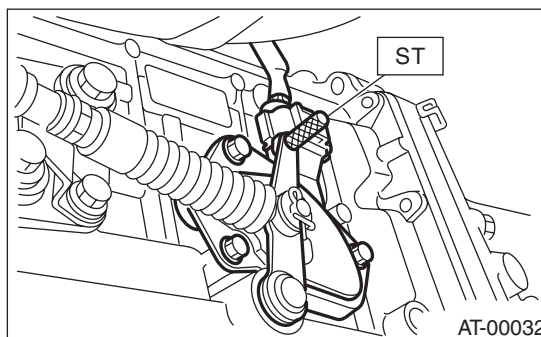

4) Tighten the three inhibitor switch bolts.

Tightening torque:

3.5 N·m (0.36 kgf-m, 2.6 ft-lb)

5) Repeat the above checks. If the inhibitor switch is determined to be "faulty", replace it.

C: REMOVAL

- 1) Set up the vehicle on a lift.
- 2) Move the select lever to "N" range.
- 3) Remove the air cleaner case or air intake chamber. (Non-TURBO model)
<Ref. to IN(H4SO)-6, REMOVAL, Air Cleaner Case.>
- 4) Remove the intercooler. (TURBO model)
<Ref. to IN(H4DOTC)-10, REMOVAL, Intercooler.>
- 5) Disconnect the inhibitor switch connector.

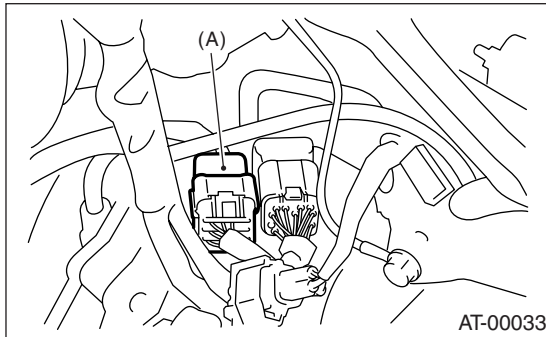

(A) Inhibitor switch connector

- 6) Remove the inhibitor switch connector from stay.
- 7) Lift-up the vehicle.
- 8) Remove the front and center exhaust pipes.
NON-TURBO model
<Ref. to EX(H4SO)-5, REMOVAL, Front Exhaust Pipe.>
TURBO model
<Ref. to EX(H4DOTC)-9, REMOVAL, Center Exhaust Pipe.>

9) Remove the snap pin and washer from range select lever.

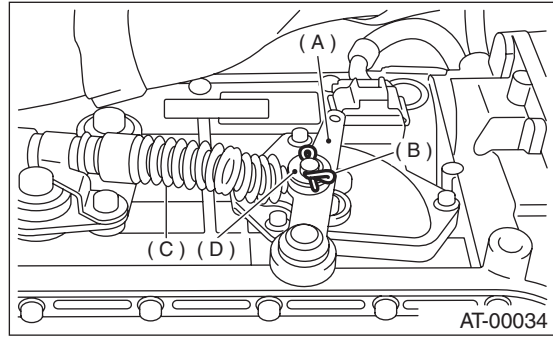

(A) Range select lever
(B) Snap pin
(C) Select cable
(D) Washer

10) Remove the plate assembly from transmission case.

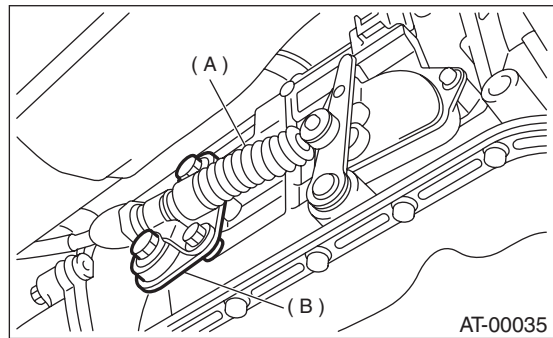

(A) Select cable
(B) Plate ASSY

11) Remove the bolts.

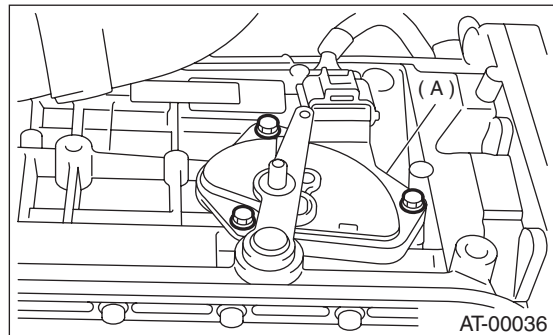

(A) Inhibitor switch

INHIBITOR SWITCH

AUTOMATIC TRANSMISSION

12) Move the range select lever to parking position (left side).

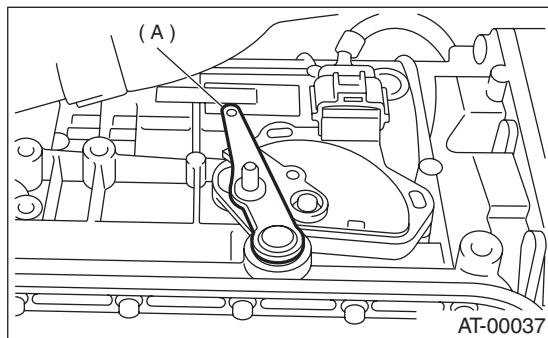

(A) Range select lever

13) Remove the inhibitor switch from transmission.

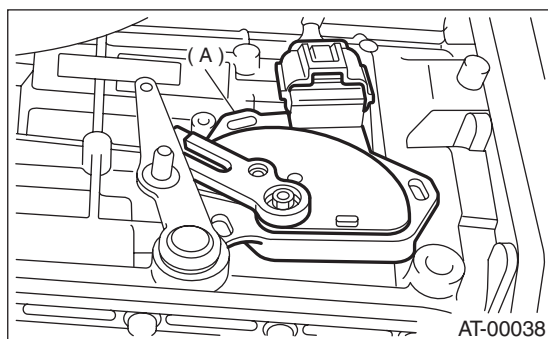

(A) Inhibitor switch

14) Disconnect the inhibitor switch harness connector from inhibitor switch.

D: INSTALLATION

1) Connect the inhibitor switch harness connector to inhibitor switch.

2) Install the inhibitor switch to transmission case.

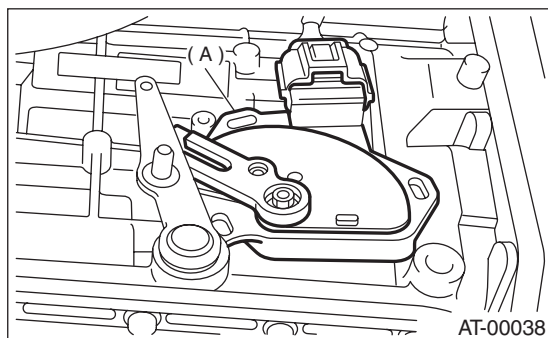

(A) Inhibitor switch

3) Move the range select lever to neutral position.

4) Using the ST, tighten the bolts of inhibitor switch.
ST 499267300 STOPPER PIN

Tightening torque:

3.5 N·m (0.36 kgf·m, 2.6 ft·lb)

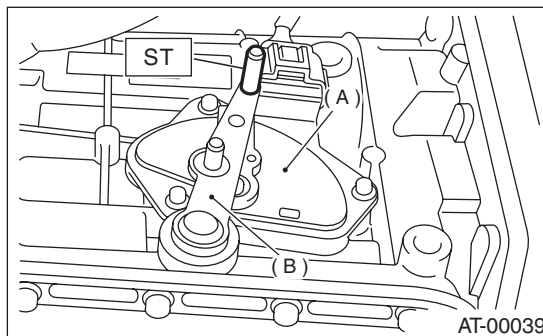

(A) Inhibitor switch
(B) Range select lever

5) Install the select cable to range select lever.

6) Install the plate assembly to transmission.

Tightening torque:

T: 25 N·m (2.5 kgf·m, 18.1 ft·lb)

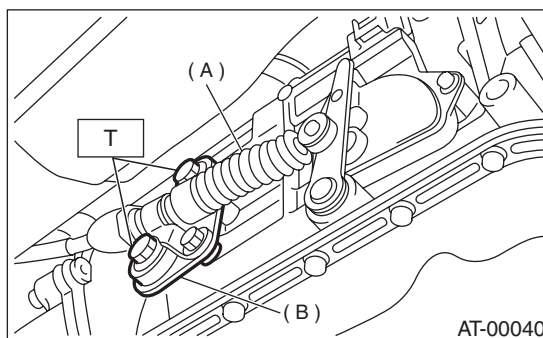

(A) Select cable
(B) Plate ASSY

7) Install the washer and snap pin to range select lever.

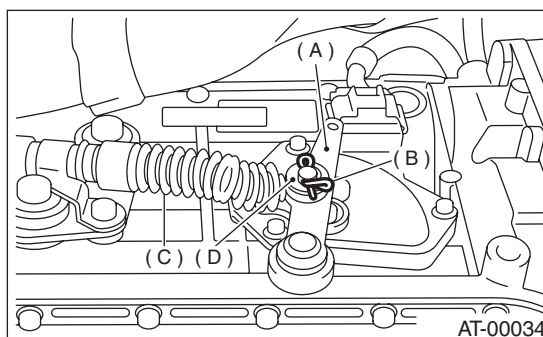

(A) Range select lever
(B) Snap pin
(C) Select cable
(D) Washer

- 8) Install the front and center exhaust pipes. (Non-TURBO model)
<Ref. to EX(H4SO)-6, INSTALLATION, Front Exhaust Pipe.>
- 9) Install the center exhaust pipe. (TURBO model)
<Ref. to EX(H4DOTC)-10, INSTALLATION, Center Exhaust Pipe.>
- 10) Lower the vehicle.
- 11) Install the inhibitor switch connector from stay.
- 12) Connect the inhibitor switch connector.

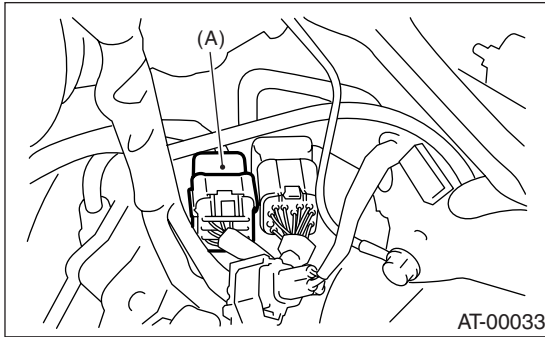

(A) Inhibitor switch connector

- 13) Install the air cleaner case or air intake chamber. (Non-TURBO model)
<Ref. to IN(H4SO)-6, INSTALLATION, Air Cleaner Case.>
- 14) Install the intercooler. (TURBO model)
<Ref. to IN(H4DOTC)-11, INSTALLATION, Intercooler.>
- 15) Inspect the inhibitor switch. <Ref. to 4AT-50, INSPECTION.>