

## 19. Shift Solenoids, Duty Solenoids and ATF Temperature Sensor

### A: REMOVAL

#### 1. SHIFT SOLENOIDS AND DUTY SOLENOIDS

- 1) Lift-up the vehicle.
- 2) Clean the transmission exterior.
- 3) Replace the gasket with a new one, and tighten the drain plug.
- 4) Drain the ATF completely.

#### Tightening torque:

**25 N·m (2.5 kgf-m, 18.1 ft-lb)**

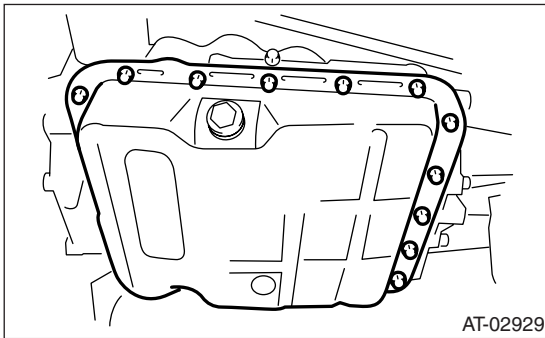

- 5) Remove the oil pan.
- 6) Disconnect the solenoid and duty solenoid connectors.

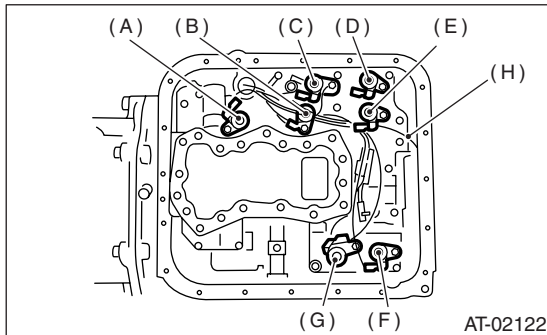

- (A) Lock-up duty solenoid (Blue)
- (B) Low clutch timing solenoid (Gray)
- (C) Line pressure duty solenoid (Red)
- (D) Shift solenoid 2 (Yellow)
- (E) Shift solenoid 1 (Green)
- (F) 2-4 brake timing solenoid (Black)
- (G) 2-4 brake duty solenoid (Red)
- (H) Transfer duty solenoid (Brown)

- 7) Remove the solenoids and duty solenoids.

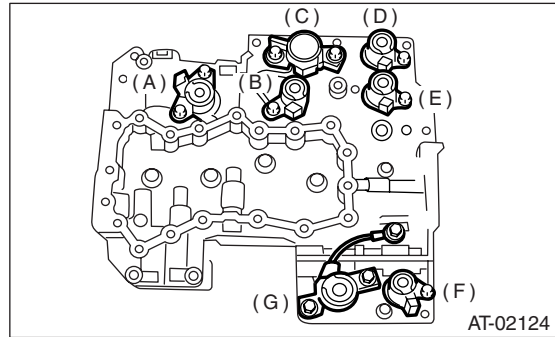

- (A) Lock-up duty solenoid (Blue)
- (B) Low clutch timing solenoid (Gray)
- (C) Line pressure duty solenoid (Red)
- (D) Shift solenoid 2 (Yellow)
- (E) Shift solenoid 1 (Green)
- (F) 2-4 brake timing solenoid (Black)
- (G) 2-4 brake duty solenoid (Red)

#### 2. ATF TEMPERATURE SENSOR

For removal of ATF temperature sensor, refer to "Front Vehicle Speed Sensor." <Ref. to 4AT-54, REMOVAL.>

### B: INSTALLATION

#### 1. SHIFT SOLENOIDS AND DUTY SOLENOIDS

- 1) Insert solenoid and duty solenoid to specified position.

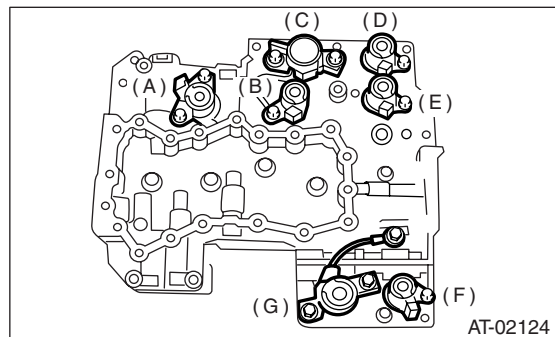

- (A) Lock-up duty solenoid (Blue)
- (B) Low clutch timing solenoid (Gray)
- (C) Line pressure duty solenoid (Red)
- (D) Shift solenoid 2 (Yellow)
- (E) Shift solenoid 1 (Green)
- (F) 2-4 brake timing solenoid (Black)
- (G) 2-4 brake duty solenoid (Red)

# SHIFT SOLENOIDS, DUTY SOLENOIDS AND ATF TEMPERATURE SENSOR

## AUTOMATIC TRANSMISSION

2) Tighten the bolts and nuts.

### Tightening torque:

**8 N-m (0.8 kgf-m, 5.8 ft-lb)**

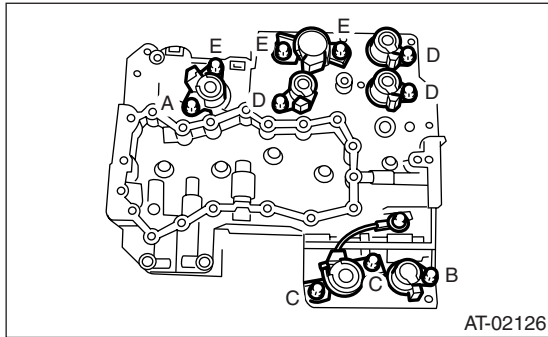

Bolt length mm (in)

- (A) 12 (0.47)
- (B) 40 (1.57)
- (C) 45 (1.77)
- (D) 62 (2.44)
- (E) 73 (2.87)

3) Connect the harness connectors.  
Connect the connectors of same color, and secure the harness to valve body using clips.

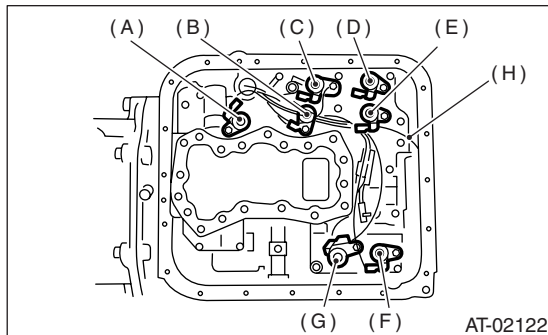

- (A) Lock-up duty solenoid (Blue)
- (B) Low clutch timing solenoid (Gray)
- (C) Line pressure duty solenoid (Red)
- (D) Shift solenoid 2 (Yellow)
- (E) Shift solenoid 1 (Green)
- (F) 2-4 brake timing solenoid (Black)
- (G) 2-4 brake duty solenoid (Red)
- (H) Transfer duty solenoid (Brown)

4) Apply proper amount of liquid gasket to the entire oil pan mating surface.

### Fluid packing:

**THREE BOND 1217B (Part No. K0877YA020)**

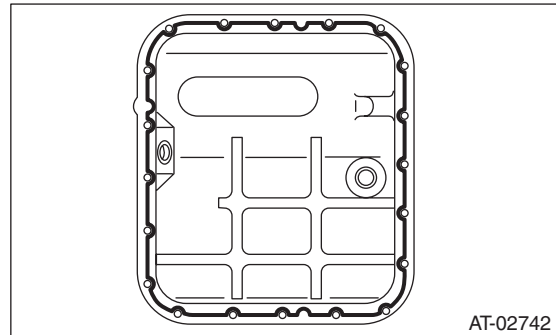

5) Apply liquid gasket fully to three holes other than screw holes on transmission case.

### Fluid packing:

**THREE BOND 1217B (Part No. K0877YA020)**

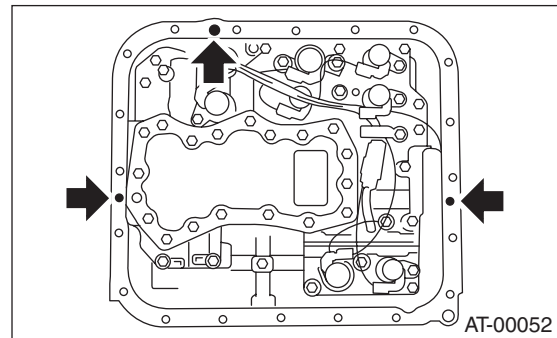

6) Tighten bolts evenly and install the oil pan.

### Tightening torque:

**5 N-m (0.5 kgf-m, 3.6 ft-lb)**

7) Refill with the same amount of ATF that was drained.

8) Check the ATF level. <Ref. to 4AT-31, Automatic Transmission Fluid.>

## 2. ATF TEMPERATURE SENSOR

For installation of ATF temperature sensor, refer to "Front Vehicle Speed Sensor." <Ref. to 4AT-56, INSTALLATION.>