

29. Transfer Clutch

A: REMOVAL

- 1) Remove the transmission assembly from vehicle. <Ref. to 4AT-39, REMOVAL.>
- 2) Remove the extension case and remove the transfer clutch. <Ref. to 4AT-85, REMOVAL.> and <Ref. to 4AT-85, REMOVAL.>

B: INSTALLATION

- 1) Select the thrust needle bearing. <Ref. to 4AT-92, ADJUSTMENT.>
- 2) Install the transfer clutch assembly to the case.

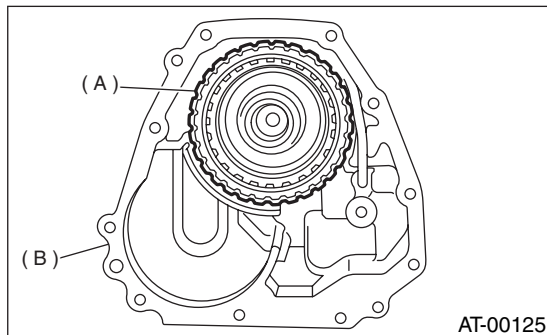

- (A) Transfer clutch
- (B) Extension case

- 3) Tighten bolts to secure the case.

Tightening torque:

25 N·m (2.5 kgf·m, 18.1 ft·lb)

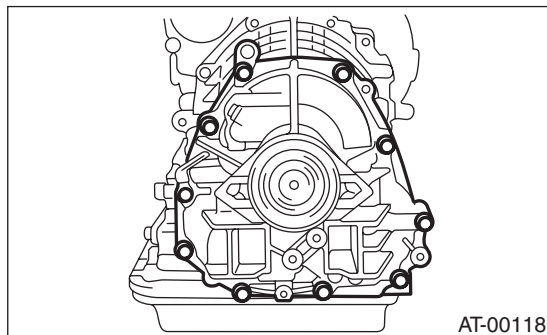

- 4) Install the transmission assembly to vehicle. <Ref. to 4AT-42, INSTALLATION.>

C: DISASSEMBLY

- 1) Remove the seal ring.

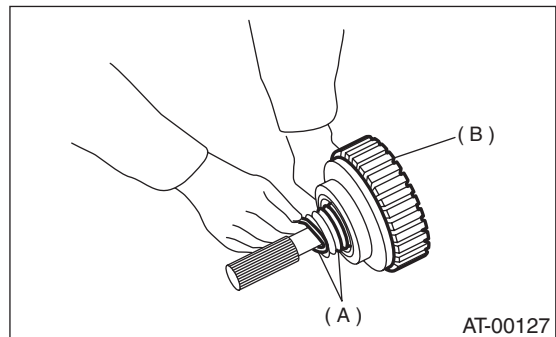

- (A) Seal ring
- (B) Transfer clutch

- 2) Using a press and ST, remove the ball bearing. ST 498077600 REMOVER

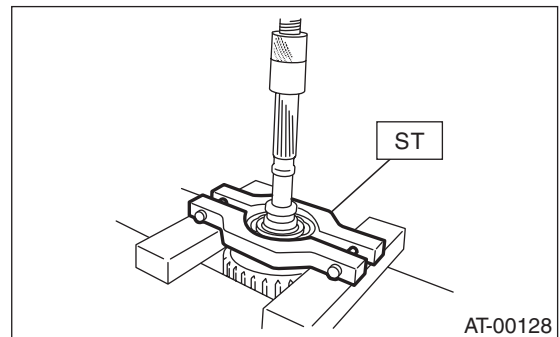

- 3) Remove the snap ring, and take out the pressure plate, drive plates, and driven plates.

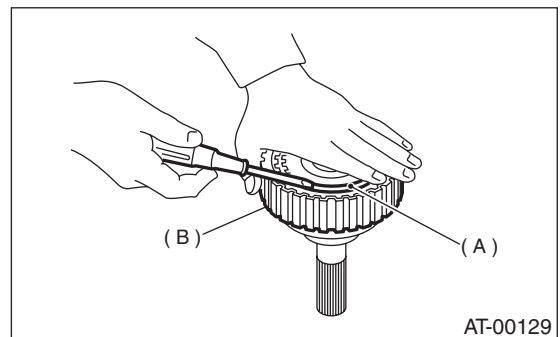

- (A) Snap ring
- (B) Transfer clutch

TRANSFER CLUTCH

AUTOMATIC TRANSMISSION

4) Remove the snap ring with ST1, ST2 and ST3, and take out the return spring and transfer clutch piston seal.

ST1 399893600 PLIERS
ST2 398673600 COMPRESSOR
ST3 398623600 SEAT

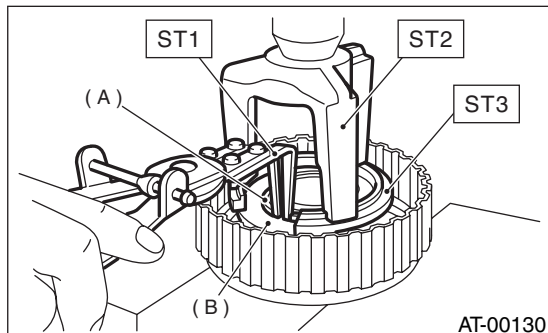

(A) Snap ring
(B) Transfer piston seal

5) Apply compressed air to the rear drive shaft to remove the piston.

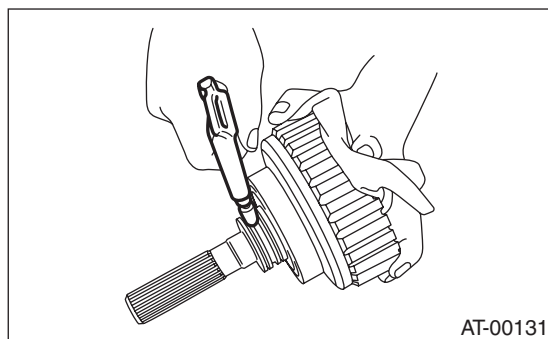

D: ASSEMBLY

1) Install the transfer clutch piston.

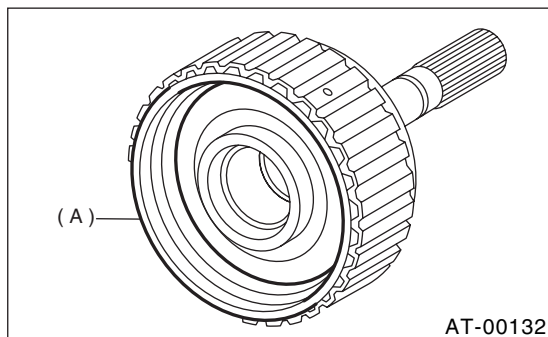

(A) Transfer clutch piston
(B) Rear drive shaft

2) Install return spring to transfer piston.

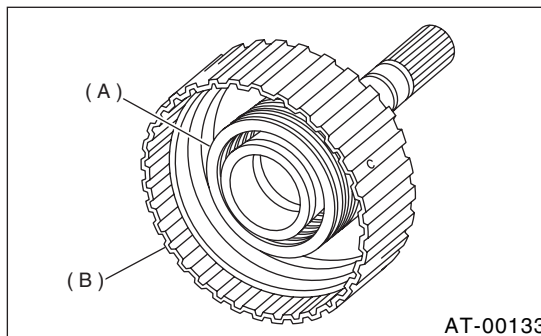

(A) Return spring
(B) Rear drive shaft

3) Install transfer clutch piston seal.

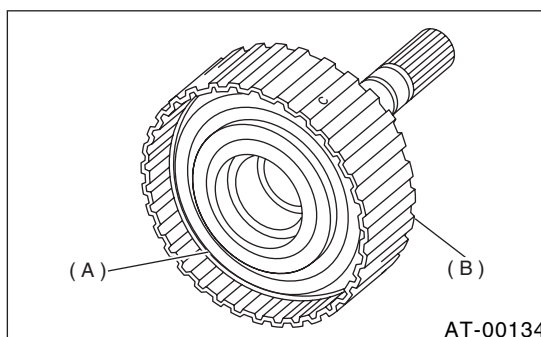

(A) Transfer clutch piston seal
(B) Rear drive shaft

4) Install ST to rear drive shaft.

ST 499257300 SNAP RING OUTER GUIDE

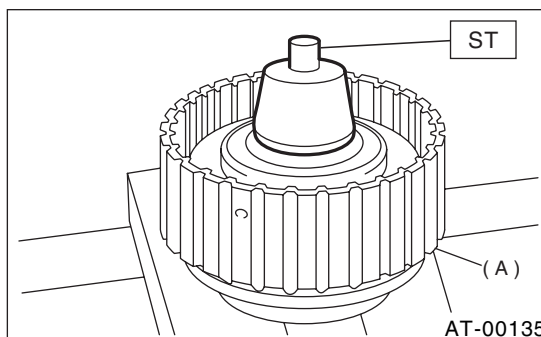

(A) Transfer clutch

TRANSFER CLUTCH

AUTOMATIC TRANSMISSION

5) Install snap ring to ST.
ST 499257300 SNAP RING OUTER GUIDE

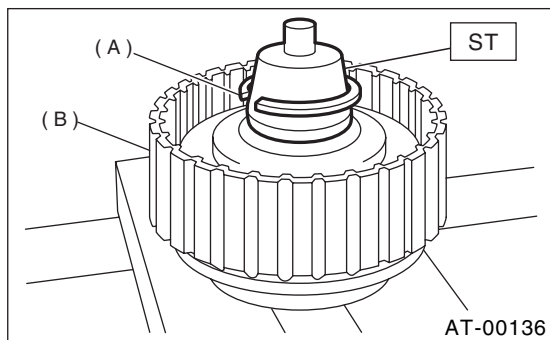

- (A) Snap ring
- (B) Transfer clutch

6) Using ST1 and ST2, install snap ring to rear drive shaft.

ST1 499257300 SNAP RING OUTER GUIDE
ST2 499247400 INSTALLER

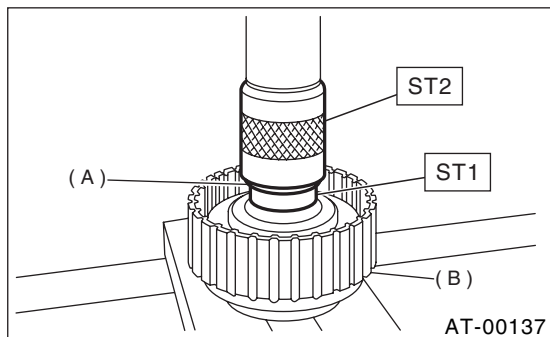

- (A) Snap ring
- (B) Transfer clutch

7) Install the driven plates, drive plates, pressure plate and snap ring.

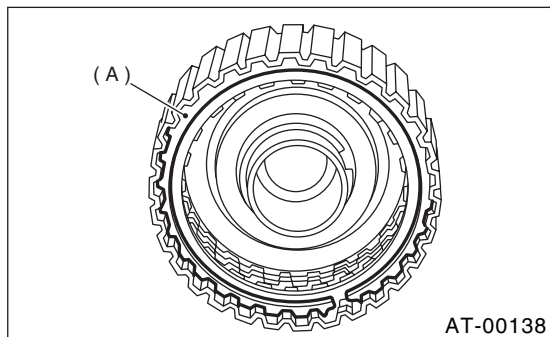

- (A) Snap ring

8) Apply compressed air to see if the assembled parts move smoothly.

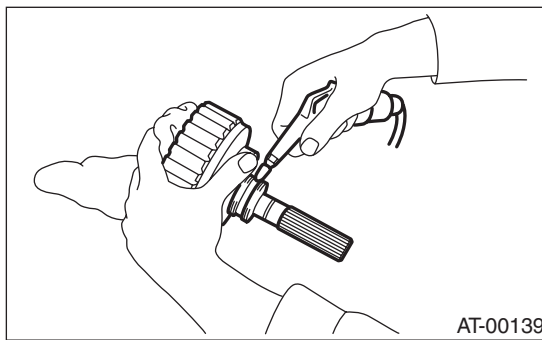

9) Check clearance between snap ring and pressure plate. <Ref. to 4AT-92, INSPECTION.>

10) Press-fit a new ball bearing with ST.
ST 899580100 INSTALLER

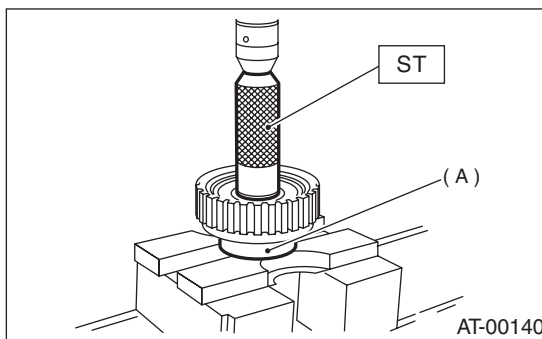

- (A) Ball bearing

11) Coat a new seal ring with vaseline, and install it in the seal ring groove of the shaft.

NOTE:

Do not expand the seal ring excessively when installing.

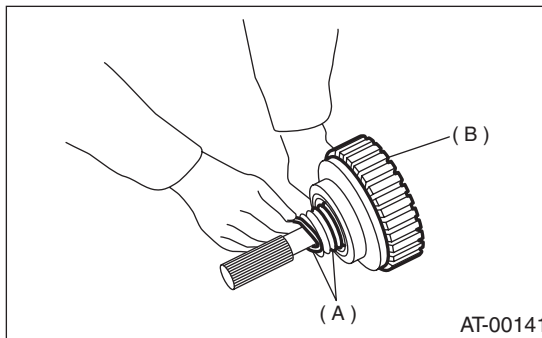

- (A) Snap ring
- (B) Transfer clutch

TRANSFER CLUTCH

AUTOMATIC TRANSMISSION

12) Install the transfer clutch assembly without damaging seal ring.

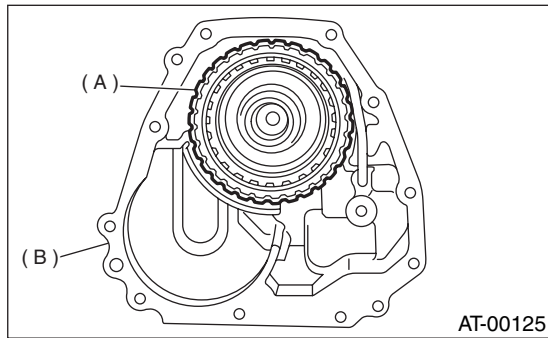

- (A) Transfer clutch
- (B) Extension case

E: INSPECTION

- Check the drive plate facing for wear and damage.
- Check the snap ring for wear, return spring for permanent set and breakage, and return spring for deformation.
- Check the lathe cut seal ring for damage.
- Measure the extension end play and adjust it to within specifications.

<Ref. to 4AT-92, ADJUSTMENT.>

- 1) Inspect clearance between snap ring and pressure plate.
 - 2) Before measuring clearance, place the same thickness of shim on both sides to prevent pressure plate from tilting.
 - 3) If the clearance is not within specification, adjust it by selecting a suitable pressure plate on the transfer clutch piston side.
- If the clearance is above the limit, replace the drive plate with new one and adjust so that the clearance is within specification.

Standard value:

0.7 — 1.1 mm (0.028 — 0.043 in)

Allowable limit:

1.6 mm (0.063 in)

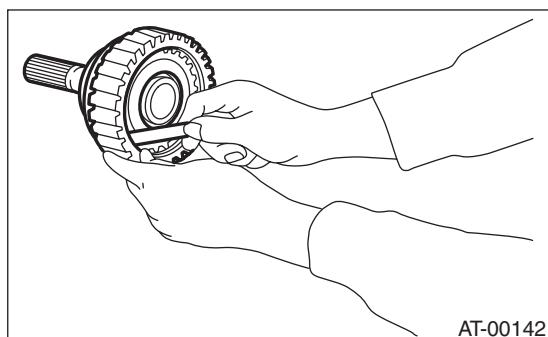

Pressure plates	
Part No.	Thickness mm (in)
31593AA151	3.3 (0.130)
31593AA161	3.7 (0.146)
31593AA171	4.1 (0.161)
31593AA181	4.5 (0.177)

4) Check if the tight corner braking does not occur when the vehicle is started with steering wheel held at fully turned position. If tight corner braking occurs, perform the following procedures.

(1) With the steering wheel held at fully turned position, drive the vehicle in "D" range and with vehicle speed at approx. 5 km/h (3 MPH) in both clockwise and counterclockwise directions for approx. ten times each, while repeating acceleration and braking intermittently.

(2) If the tight corner braking still persists, drive the vehicle again in a circle for several laps.

F: ADJUSTMENT

1. MPT MODEL

1) Measure distance "A" from end of extension case and rear drive shaft with ST.

ST 398643600 GAUGE

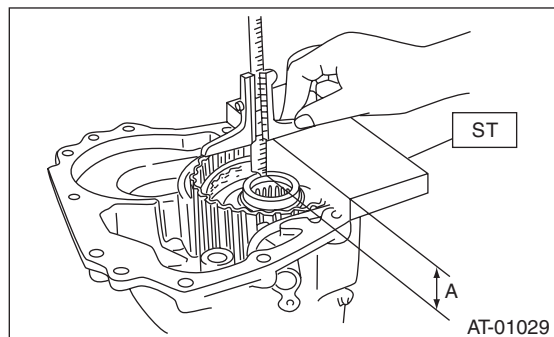

A: Measured value

TRANSFER CLUTCH

AUTOMATIC TRANSMISSION

2) Measure the distance “B” from the transmission case mating surface to the reduction drive gear end surface with ST1 and ST2.

ST1 398643600 GAUGE

ST2 499577000 GAUGE

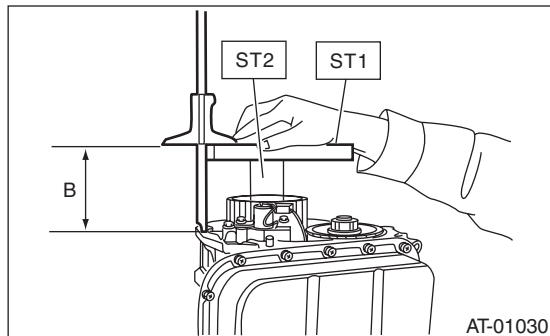

B: Measured value

3) Calculation formula:

NOTE:

- Calculate “T”:

$$T = A - B + 35.4 \text{ mm}$$

$$[T = A - B + 1.3937 \text{ in}]$$

T: Thrust needle bearing thickness

A: Distance from end of extension case to end of rear drive shaft

B: Distance from end of transmission case to end of reduction drive gear

Example:

When, A = 33.6 mm (1.3228 in), B = 65.05 mm (2.5610 in)

$$T = 33.6 - 65.05 + 35.4 = 3.95$$

$$[T = 1.3228 - 2.5610 + 1.3937 = 0.1555]$$

After calculation, the value of “H” becomes 3.95, therefore select bearing thickness of 3.8.

- Calculation formula for “T” is applied when measuring using ST (398643600 GAUGE, 499577000 GAUGE). When not using ST, apply

$$T = (A - \alpha + 0.45 \text{ mm}) - (B - \beta) - H$$

$$[T = (A - \alpha + 0.0177 \text{ in}) - (B - \beta) - H].$$

T: Thrust needle bearing thickness

A: Distance from end of extension case to end of reduction drive shaft

B: Distance from end of transmission case to end of rear drive shaft

α : Collar thickness used when measuring “A”

β : Collar thickness used when measuring “B”

0.45: Gasket thickness (mm)

H: Shim clearance

Thrust needle bearing	
Part No.	Thickness mm (in)
806536020	3.8 (0.150)
806535030	4.0 (0.157)
806535040	4.2 (0.165)
806535050	4.4 (0.173)
806535060	4.6 (0.181)
806535070	4.8 (0.189)
806535090	5.0 (0.197)

2. VTD MODEL

1) Insert the rear driveshaft into the reduction drive gear and center differential assembly.

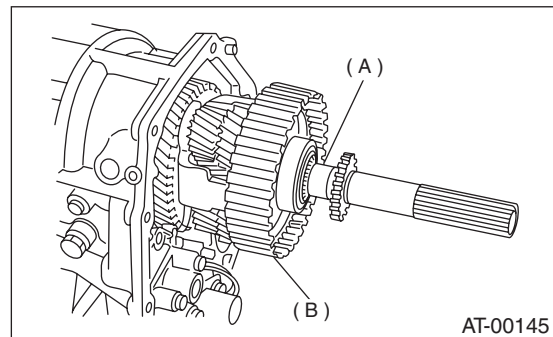

(A) Rear drive plate

(B) Center differential carrier

2) Using the special tool, measure the distance “A” between the mating surface of extension case and multi-plate clutch (LSD) piston.

ST 398643600 GAUGE

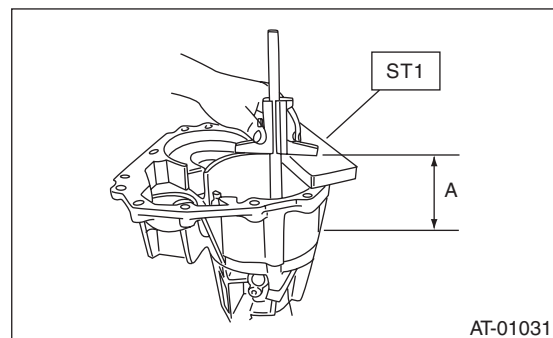

A: Measured value

TRANSFER CLUTCH

AUTOMATIC TRANSMISSION

3) Using the special tool, measure the distance “B” between the mating surface of transmission case and reduction drive gear edge.

ST 398643600 GAUGE

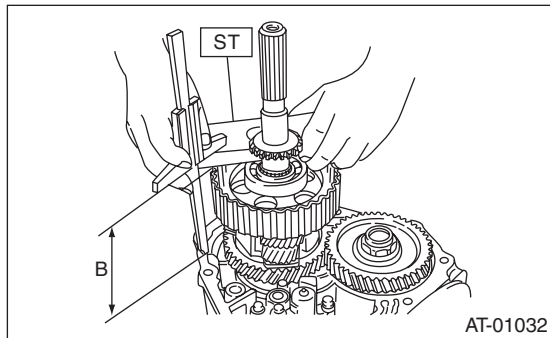

B: Measured value

4) Formula:

NOTE:

- Calculation of “T”:

When clearances are 0.05 mm (0.0020 in), select up to four adjusting shims from the table, suitable for clearance value.

When clearances are 0.05 mm (0.0020 in)

$$T = A - B + 0.40 \text{ mm}$$

$$[T = A - B + 0.0157 \text{ in}]$$

When clearances are 0.25 mm (0.0098 in)

$$T = A - B + 0.20 \text{ mm}$$

$$[T = A - B + 0.0079 \text{ in}]$$

T: Shim clearance

A: Distance between extension case edge and rear driveshaft edge

B: Distance between transmission case edge and reduction drive gear edge

T: Shim thickness

0.05 — 0.25 mm (0.0020 — 0.0098 in)

Example:

When, A = 90.50 mm (3.5630 in), B = 90.35 mm (3.5571 in)

Calculation for 0.05 mm (0.0020 in) of clearance

$$T = 90.50 - 90.35 + 0.4 = 0.55$$

$$[T = 3.5630 - 3.5571 + 0.0157 = 0.0216]$$

Calculation when clearance is 0.25 mm (0.0098 in)

$$T = 90.50 - 90.35 + 0.2 = 0.35$$

$$[T = 3.5630 - 3.5571 + 0.0079 = 0.0138]$$

- Calculation formula for “T” is applied when measuring using ST (398643600 GAUGE). When not using ST, apply

$$T = (A - \alpha + 0.45 \text{ mm}) - (B - \beta) - H$$

$$[T = (A - \alpha + 0.0177 \text{ in}) - (B - \beta) - H]$$

T: Thrust needle bearing thickness

A: Distance from end of extension case to end of reduction drive shaft

B: Distance from end of transmission case to end of rear drive shaft

α : Collar thickness used when measuring “A”

β : Collar thickness used when measuring “B”

0.45: Gasket thickness (mm)

H: Shim clearance

After calculation, the value of “T” becomes between 0.35 mm (0.0138 in) and 0.55 mm (0.0216 in), therefore select two shims with thickness of 0.2 mm (0.010 in) or one shim with thickness of 0.5 mm (0.020 in).

Adjusting shim	
Part No.	Thickness mm (in)
33281AA001	0.2 (0.008)
33281AA011	0.5 (0.020)