

30. Multi-plate Clutch

A: REMOVAL

Remove multi-plate clutch following the same instructions as for the extension case. <Ref. to 4AT-85, REMOVAL.>

B: INSTALLATION

Install multi-plate clutch following the same instructions as for the extension case. <Ref. to 4AT-85, INSTALLATION.>

C: INSPECTION

- Inspect drive plate facing for wear and damage.
- Make sure snap ring is not worn and return spring has no permanent distortion, damage, or deformation.
- Inspect D-ring for damage.
- Measure multi-plate clutch clearance and adjust it to within the specification range. <Ref. to 4AT-95, ADJUSTMENT.>

D: ADJUSTMENT

1) Remove drive plate and driven plate from center differential carrier.

2) Using the special tool, measure distance “A” from extension case joining surface to multi-plate clutch (LSD) piston.

ST 398643600 GAUGE

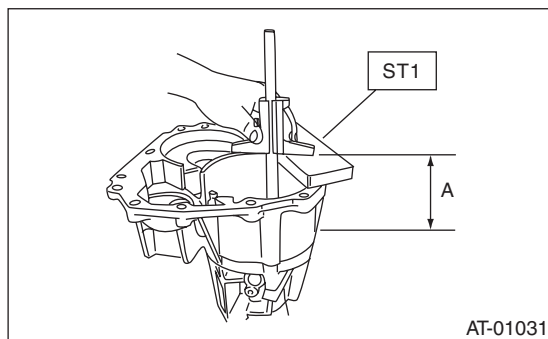

A: Measured value

3) Using ST, measure height “B” from transmission case joining edge to center differential clutch drum edge.

ST 398744300 GAUGE

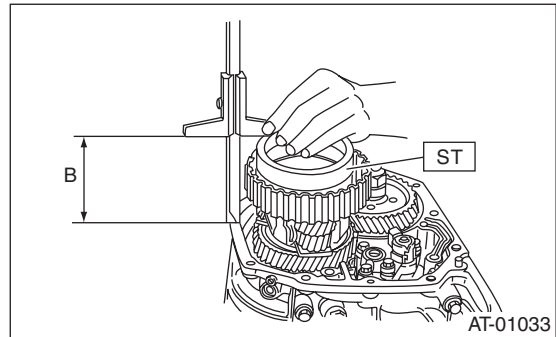

B: Measured value

4) Calculation formula

$$T = A - B + 0.45 \text{ mm}$$

$$[T = A - B + 0.0177 \text{ in}]$$

NOTE:

- Calculation formula for “T” is applied when measuring using ST (398643600 GAUGE, 398744300 GAUGE). When not using ST, apply

$$T = (A - \alpha + 0.45 \text{ mm}) - (B - \beta)$$

$$[T = (A - \alpha + 0.0177 \text{ in}) - (B - \beta)].$$

T: Thrust needle bearing thickness

A: Distance from end of extension case to end of reduction drive shaft

B: Distance from end of transmission case to end of rear drive shaft

α : Collar thickness used when measuring “A”

β : Collar thickness used when measuring “B”

0.45: Gasket thickness (mm)

- Measure multi-plate clutch (LSD) driven and drive plate thickness to find the clearance between measurement value and “T”.

Standard value:

$$0.2 - 0.6 \text{ mm } (0.008 - 0.024 \text{ in})$$

Limit value:

$$0.9 \text{ mm } (0.035 \text{ in})$$

If outside the standard value, select a pressure plate that will bring clearance within the standard value.

If the clearance is above the limit, replace the drive plate with new one and adjust so that the clearance becomes within the standard value.

Pressure plates	
Part No.	Thickness mm (in)
31589AA041	1.6 (0.063)
31589AA050	2.0 (0.079)
31589AA060	2.4 (0.094)
31589AA070	2.8 (0.110)