

## 34.Center Differential Carrier

### A: REMOVAL

- 1) Remove the transmission assembly from vehicle. <Ref. to 4AT-39, REMOVAL.>
- 2) Remove the rear wheel speed sensor, and separate the extension case from the transmission case. <Ref. to 4AT-85, REMOVAL.>
- 3) Pull out the rear driveshaft. <Ref. to 4AT-96, REMOVAL.>
- 4) Using the special tools, pull out the center differential carrier assembly.

ST1 499737000 PULLER  
ST2 899524100 PULLER SET

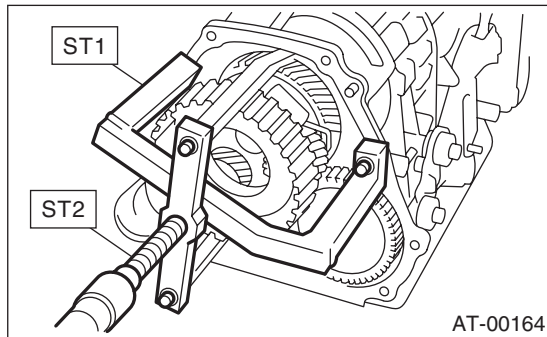

- 5) Pull out the shim(s) from transmission case.

### B: INSTALLATION

- 1) Install the center differential assembly with the shim(s).

#### NOTE:

Insert the center differential assembly and shim(s) completely into the bearing shoulder bottom.

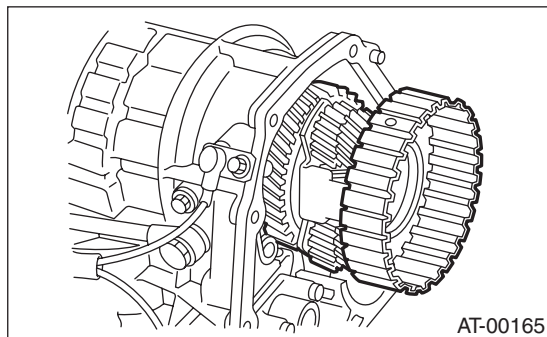

- 2) Insert the rear driveshaft. <Ref. to 4AT-96, INSTALLATION.>
- 3) Connect the transmission case and extension case, and install the rear wheel speed sensor. <Ref. to 4AT-85, INSTALLATION.>
- 4) Install the transmission assembly onto vehicle. <Ref. to 4AT-42, INSTALLATION.>

### C: DISASSEMBLY

- 1) Remove the seal rings.

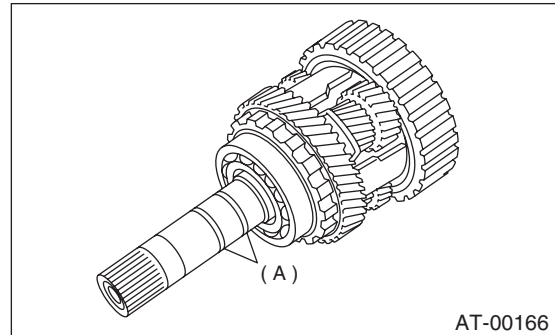

(A) Seal ring

- 2) Using a press and the ST, remove the ball bearing.

ST 498077600 REMOVER

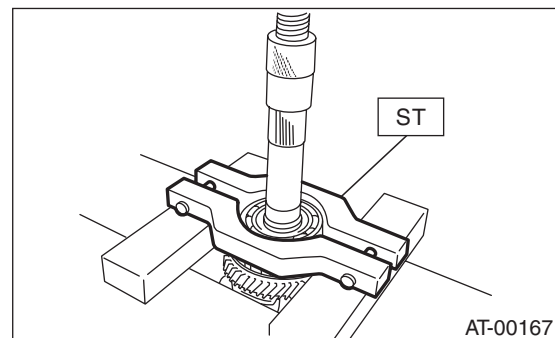

- 3) Remove the snap ring, and pull out the shaft from the center differential assembly.

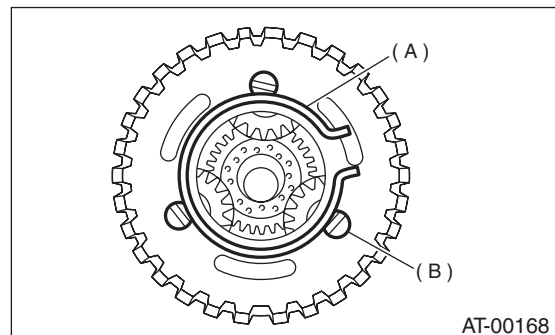

(A) Snap ring  
(B) Shaft

# CENTER DIFFERENTIAL CARRIER

## AUTOMATIC TRANSMISSION

4) Remove the thrust washers, pinion gears, and washers from the center differential assembly.

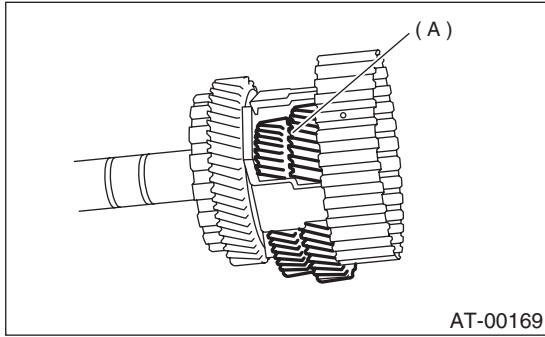

(A) Pinion gear

5) Pull out the intermediate shaft and thrust bearing.

### D: ASSEMBLY

- 1) Install the thrust washer onto the intermediate shaft.
- 2) Install thrust bearing onto the intermediate shaft.
- 3) Install the pinion gears and washers.
- 4) Insert the shaft into the center differential assembly.
- 5) Install the snap ring.
- 6) Using a press, install a new ball bearing into the center differential assembly.

ST 498077000 REMOVER

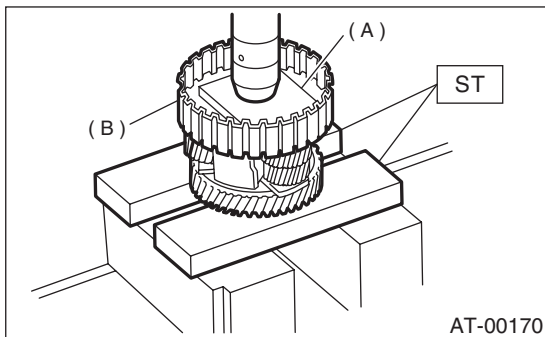

(A) Plate

(B) Center differential carrier

7) Apply Vaseline onto the seal ring outer surface and shaft grooves.

8) Install new seal rings.

### E: INSPECTION

- Check all parts for hole, score, or dirt.
- Check the play of the extension end, and if necessary, adjust it. <Ref. to 4AT-93, VTD MODEL.>