

TORQUE CONVERTER CLUTCH CASE

AUTOMATIC TRANSMISSION

36. Torque Converter Clutch Case

A: REMOVAL

- 1) Remove the transmission assembly from the vehicle. <Ref. to 4AT-39, REMOVAL.>
- 2) Extract the torque converter clutch assembly. <Ref. to 4AT-84, REMOVAL.>
- 3) Remove the input shaft.

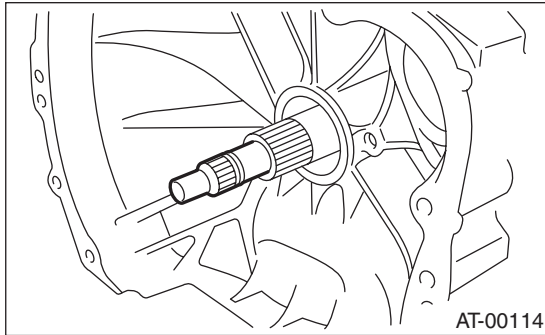

- 4) Lift-up lever behind the connector and disconnect it from stay.
- 5) Disconnect inhibitor switch connector from stay.

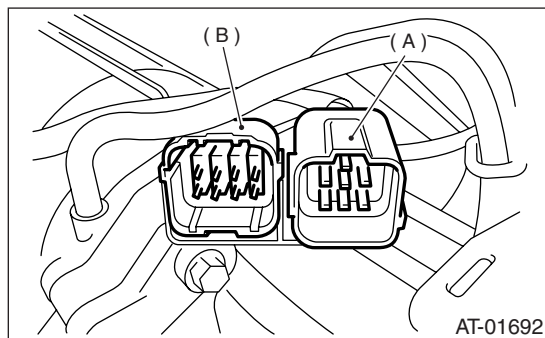

- (A) Transmission harness
- (B) Inhibitor switch harness

- 6) Remove the oil charger pipe. <Ref. to 4AT-83, REMOVAL.>
- 7) Remove the oil cooler inlet and outlet pipes. <Ref. to 4AT-80, REMOVAL.>
- 8) Lightly tapping the torque converter clutch case with plastic hammer, separate the transmission case and torque converter clutch case.

NOTE:

- Be careful not to damage the oil seal and bushing inside the torque converter clutch case by the oil pump cover.

- Be careful not to lose the rubber seal.

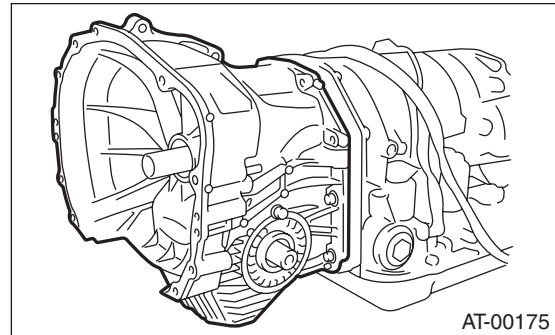

- 9) Remove the seal pipe if it is attached. (Reusing is not allowed.)

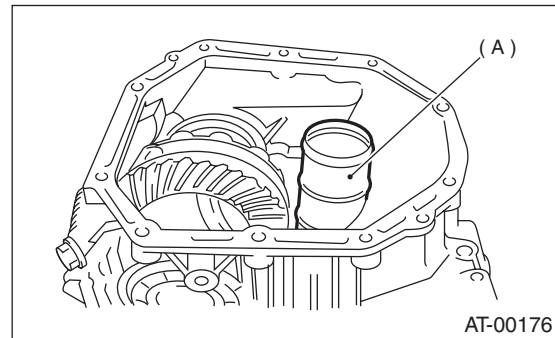

- (A) Seal pipe

- 10) Remove the differential assembly. <Ref. to 4AT-116, REMOVAL.>
- 11) Remove the oil seal from torque converter clutch case.

B: INSTALLATION

- 1) Check the appearance of each component and clean.
- 2) Force-fit the oil seal to the torque converter clutch case with ST.
ST 398437700 DRIFT

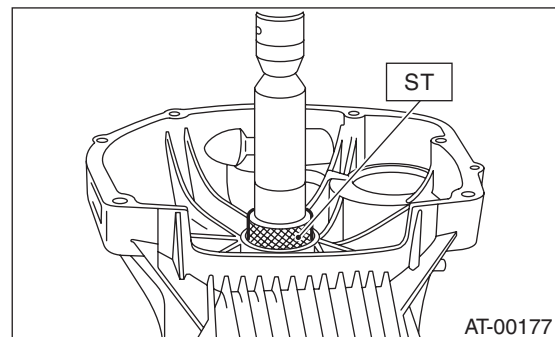

- 3) Install the differential assembly to the case. <Ref. to 4AT-116, INSTALLATION.>
- 4) Install the left and right side retainers. <Ref. to 4AT-120, ADJUSTMENT.>

TORQUE CONVERTER CLUTCH CASE

AUTOMATIC TRANSMISSION

5) Install the new seal pipe to the torque converter clutch case.

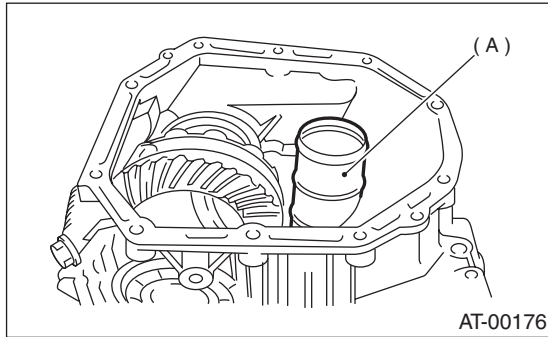

(A) Seal pipe

6) Install the rubber seal to the torque converter clutch case.

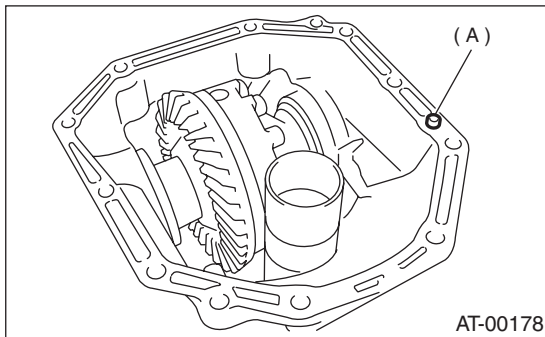

(A) Rubber seal

7) Apply proper amount of liquid gasket to the entire torque converter clutch case mating surface.

Liquid gasket:

THREE BOND 1215 (Part No. 004403007)

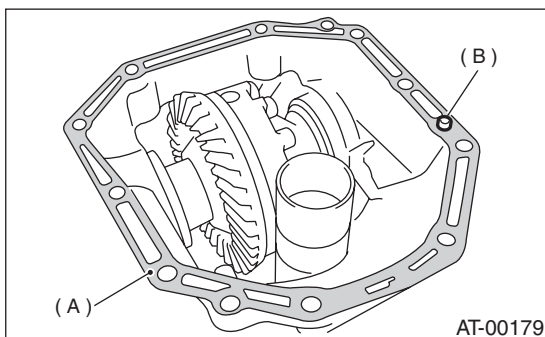

(A) THREE BOND 1215

(B) Rubber seal

8) Install the torque converter clutch case assembly without damaging bush and oil seal and secure with six bolts and four nuts.

Tightening torque:

41 N·m (4.2 kgf·m, 30.4 ft·lb)

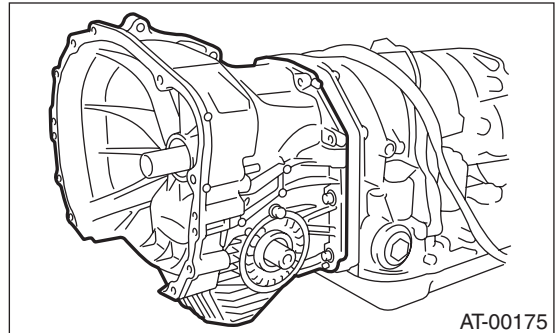

9) Insert inhibitor switch and transmission connector into stay.

10) Install air breather hose. <Ref. to 4AT-82, INSTALLATION.>

11) Install the oil cooler pipes. <Ref. to 4AT-81, INSTALLATION.>

12) Install the oil charger pipe with O-ring. <Ref. to 4AT-83, INSTALLATION.>

13) Insert the input shaft while turning lightly by hand and verify the protrusion amount.

Normal protrusion A:

50 — 55 mm (1.97 — 2.17 in)

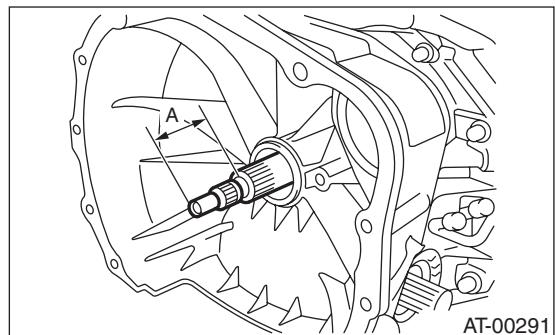

14) Install the torque converter clutch assembly. <Ref. to 4AT-84, INSTALLATION.>

15) Install the transmission assembly to the vehicle. <Ref. to 4AT-42, INSTALLATION.>

C: INSPECTION

Measure the backlash and adjust to within specifications. <Ref. to 4AT-113, ADJUSTMENT.>