

4. Release Bearing and Lever

A: REMOVAL

1. NON-TURBO MODEL

1) Remove the transmission assembly from vehicle body. <Ref. to 5MT-27, REMOVAL, Manual Transmission Assembly.>

2) Remove the two clips from clutch release lever and remove the release bearing.

CAUTION:

Be careful not to deform clips.

3) Remove the dust cover.

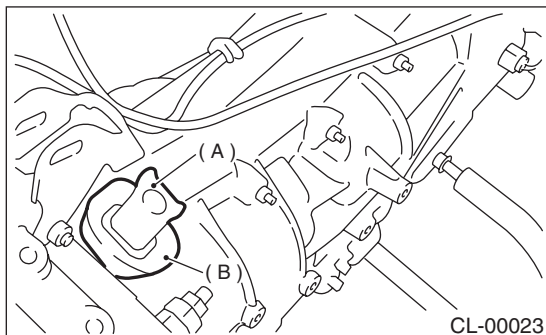

(A) Clutch release lever
(B) Dust cover

4) Remove the retainer spring from pivot with a screwdriver by accessing it through release lever hole. Then remove the release lever.

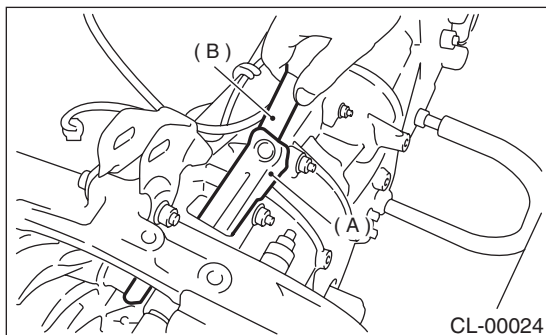

(A) Clutch release lever
(B) Screwdriver

2. TURBO MODEL

1) Remove the transmission assembly from vehicle body.

<Ref. to 5MT-27, REMOVAL, Manual Transmission Assembly.>

2) Remove the clutch release lever from transmission.

3) Put the clutch release bearing in engine side.

4) Remove the clutch release bearing from the clutch cover using flat-type screwdriver.

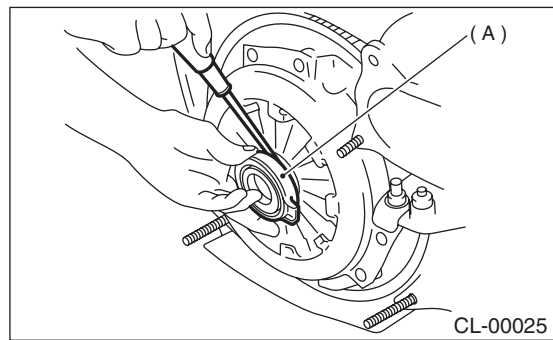

(A) Clutch release bearing

B: INSTALLATION

1. NON-TURBO MODEL

1) Before assembly, lubricate the following points with a coat of grease.

- Contact surface of lever and pivot
- Contact surface of lever and bearing
- Transmission main shaft spline (Use grease containing molybdenum disulphide.)
- Contact surface of lever and operating cylinder

2) While pushing the fork to pivot and twisting it to both sides, fit the retainer spring onto the constricted portion of pivot.

Apply grease (SUNLIGHT 2: P/N 003602010) to the contact point of release lever and operating cylinder.

3) Confirm that the retainer spring is securely fitted by observing it through the release lever hole.

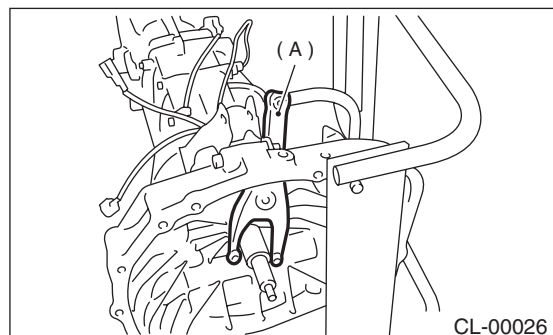

(A) Release lever

4) Install the release bearing and fasten it with two clips.

RELEASE BEARING AND LEVER

CLUTCH SYSTEM

5) Install the release lever dust cover.

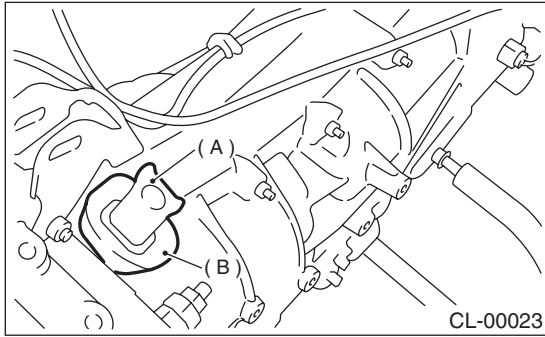

- (A) Release lever
- (B) Dust cover

6) Verify that the bearing moves smoothly with operating release fork.

7) Install the transmission assembly. <Ref. to 5MT-30, INSTALLATION, Manual Transmission Assembly.>

2. TURBO MODEL

- 1) Install the release bearing on transmission.
- 2) Insert the release fork into release bearing tab.

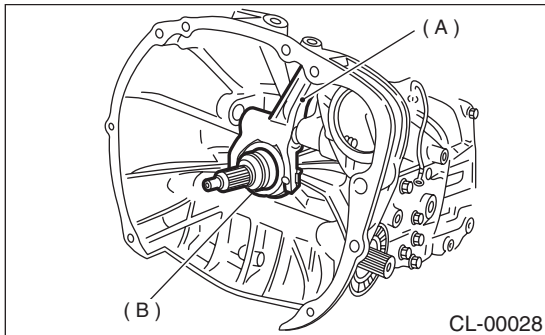

- (A) Release fork
- (B) Release bearing

3) Apply grease to the specified points:
Spline FX2200 (Part No. 000040901)

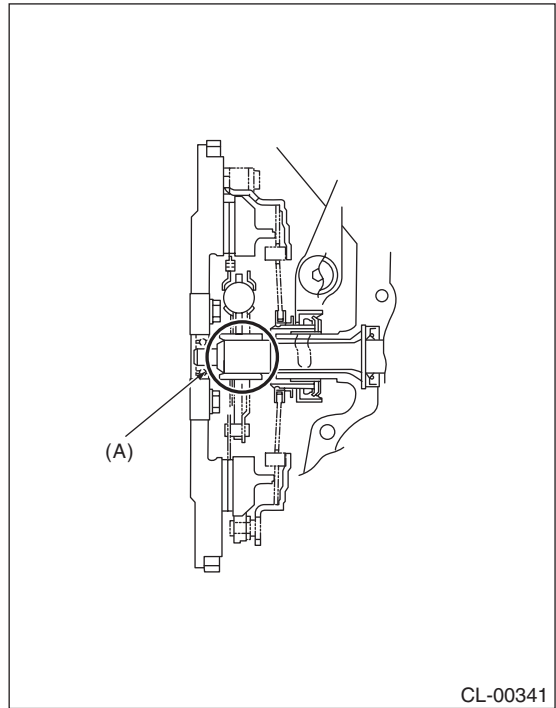

- (A) Spline (FX2200)

4) Insert the fork shaft into release fork.

NOTE:

Make sure the cutout portion of fork shaft contacts spring pin.

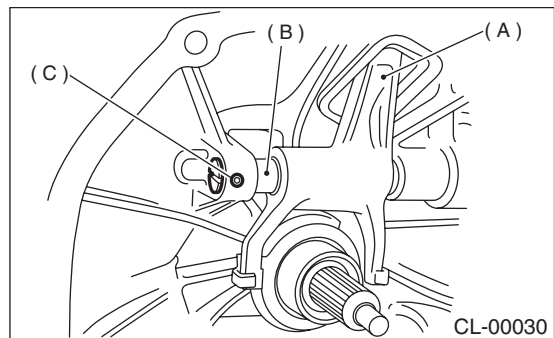

- (A) Release fork
- (B) Release shaft
- (C) Spring pin

5) Tighten the plug.

Tightening torque:
44 N·m (4.5 kgf·m, 32.5 ft·lb)

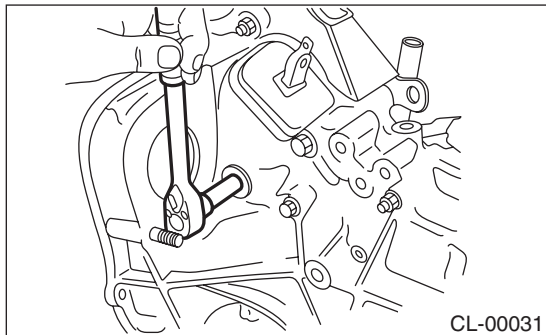

2) Check the bearing for smooth rotation by applying pressure in the thrust direction.

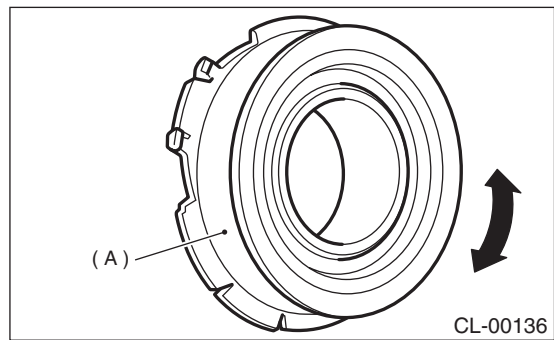

6) Install the transmission assembly.
 <Ref. to 5MT-30, INSTALLATION, Manual Transmission Assembly.>

C: INSPECTION

1. RELEASE BEARING

NOTE:

Since this bearing is grease sealed and is of a non-lubrication type, do not wash with gasoline or any solvent when servicing the clutch.

1) Check the bearing for smooth movement by applying force in the radial direction.

Radial direction stroke:
1.6 mm (0.063 in)

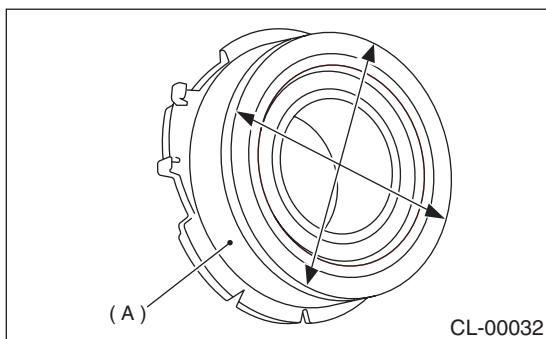

(A) Bearing case

3) Check wear and damage of the bearing case surface contacting with lever.

2. RELEASE LEVER

1) Check the lever pivot portion and the point of contact with release bearing case for wear.

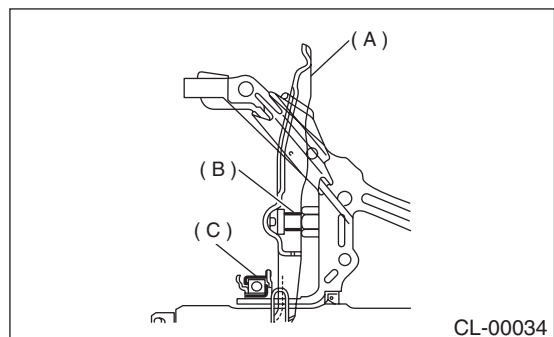

(A) Clutch release lever
 (B) Pivot
 (C) Clutch release bearing