

# MASTER CYLINDER

## CLUTCH SYSTEM

### 6. Master Cylinder

#### A: REMOVAL

- 1) Thoroughly drain the brake fluid from reservoir tank.
- 2) Remove the snap pin, clevis pin and separate the push rod of master cylinder from clutch pedal.

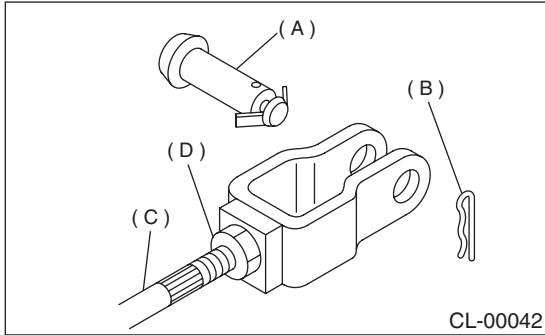

- (A) Clevis pin
- (B) Snap pin
- (C) Push rod
- (D) Lock nut

- 3) Remove the air cleaner case and air intake duct. <Ref. to IN(H4SO)-6, REMOVAL, Air Cleaner Case.> and <Ref. to IN(H4SO)-7, REMOVAL, Air Intake Duct.>
- 4) Remove the intercooler. <Ref. to IN(H4DOTC)-10, REMOVAL, Intercooler.>
- 5) Remove the clutch pipe from master cylinder.
- 6) Remove the master cylinder with reservoir tank.

#### CAUTION:

**Be extremely careful not to spill brake fluid. Brake fluid spilt on the vehicle body will harm the paint surface; immediately flush it away with water, and then wipe it off if spilt.**

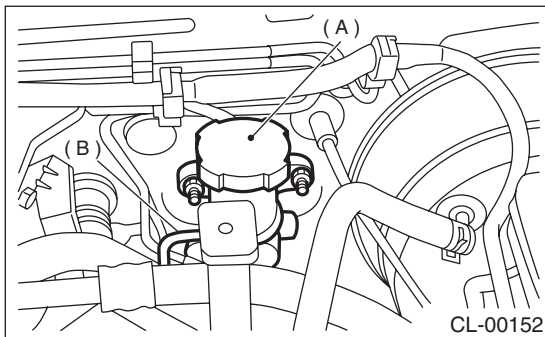

- (A) Master cylinder
- (B) Clutch pipe

#### B: INSTALLATION

- 1) Install the master cylinder to body, and install the clutch pipe to master cylinder.

#### NOTE:

Check that the pipe is routed properly.

#### Tightening torque:

- T1: 15 N·m (1.5 kgf-m, 10.8 ft-lb)
- T2: 18 N·m (1.8 kgf-m, 13.0 ft-lb)

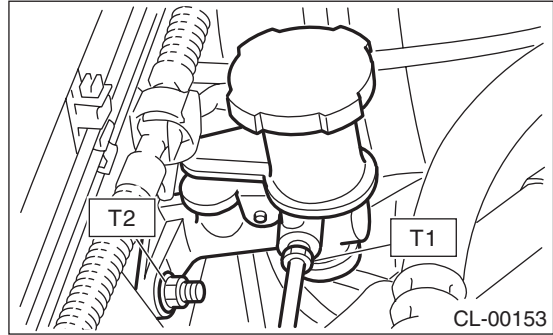

- 2) Apply a coat of grease to the clevis pin.
- 3) Connect the push rod of master cylinder to clutch pedal, and install the new clevis pin and snap pin.

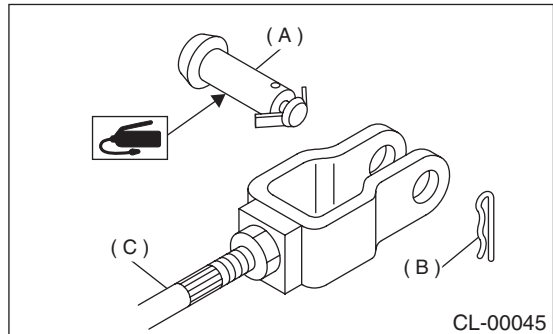

- (A) Clevis pin
- (B) Snap pin
- (C) Push rod

- 4) After bleeding air from the system, ensure that clutch operates properly.
- 5) Adjust the clutch pedal. <Ref. to CL-28, ADJUSTMENT, Clutch Pedal.>
- 6) Install the air cleaner case and air intake duct. <Ref. to IN(H4SO)-6, INSTALLATION, Air Cleaner Case.> and <Ref. to IN(H4SO)-7, INSTALLATION, Air Intake Duct.>
- 7) Install the intercooler. (TURBO model) <Ref. to IN(H4DOTC)-11, INSTALLATION, Intercooler.>

## C: DISASSEMBLY

1) Remove the straight pin and reservoir tank.

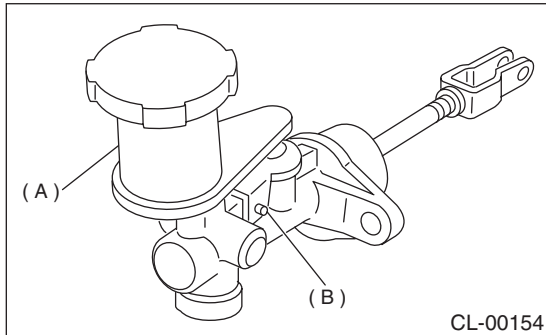

- (A) Reservoir tank
- (B) Straight pin

2) Remove the oil seal.

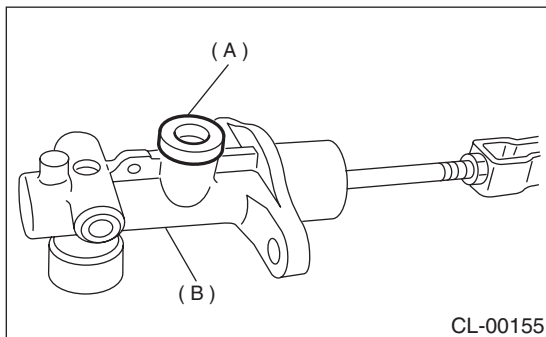

- (A) Oil seal
- (B) Master cylinder

3) Move the cylinder boot backward.

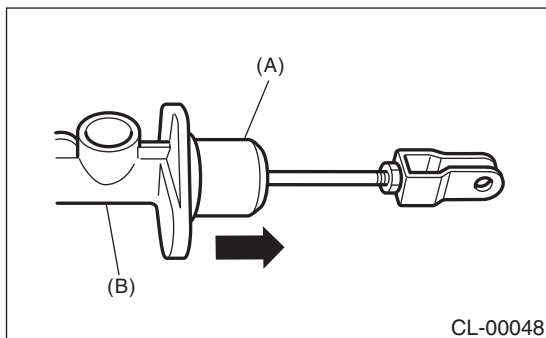

- (A) Cylinder boot
- (B) Master cylinder

4) Remove the stop ring.

**CAUTION:**  
Be careful when removing the snap ring to prevent the rod, washer, piston and return spring from flying out.

5) Remove the clutch damper. (Turbo model)

## D: ASSEMBLY

1) Install the clutch damper. (Turbo model)

**Tightening torque:**

**46.6 N·m (4.8 kgf·m, 34 ft·lb)**

2) Apply a coat of grease to the contacting surfaces of the push rod and piston before installation.

**Grease:**

**SILICONE GREASE G40M (Part No. 004404003)**

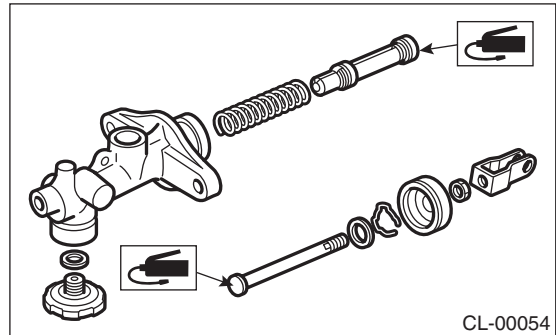

3) To assemble the master cylinder, reverse the sequence of disassembly procedure.

**Tightening torque:**

**10 N·m (1.0 kgf·m, 7 ft·lb)**

## E: INSPECTION

If any damage, deformation, wear, swelling, rust or other faults are found on the cylinder, piston, push rod, fluid reservoir, return spring, gasket, cylinder boot and hose replace the faulty part.

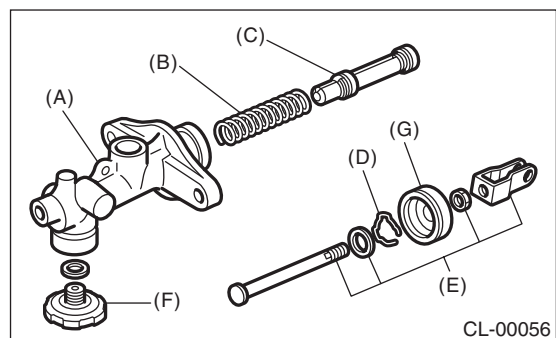

- (A) Master cylinder body
- (B) Return spring
- (C) Piston
- (D) Stop ring
- (E) Rod ASSY
- (F) Clutch damper
- (G) Cylinder boot