

5. Select Cable

A: REMOVAL

- 1) Set the vehicle on a lift.
- 2) Disconnect the ground cable from battery.
- 3) Prior to removal, set the lever to "N" position.
- 4) Lift-up the vehicle.
- 5) Remove the front and center exhaust pipe. (Non-TURBO model)
<Ref. to EX(H4SO)-5, REMOVAL, Front Exhaust Pipe.>
- 6) Remove center exhaust pipe. (TURBO model)
<Ref. to EX(H4DOTC)-9, REMOVAL, Center Exhaust Pipe.>
- 7) Remove the heat shield cover. (If equipped)
- 8) Remove the snap pin from range select lever.

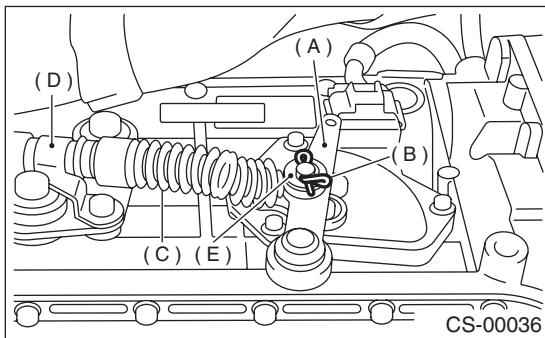

- (A) Range select lever
- (B) Snap pin
- (C) Select cable
- (D) Clamp
- (E) Washer

- 9) Remove the plate assembly from transmission case.

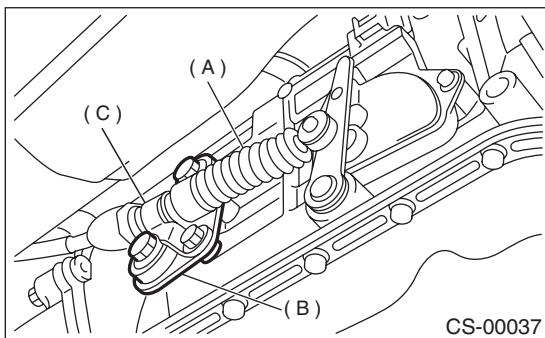

- (A) Select cable
- (B) Plate ASSY
- (C) Clamp

- 10) Disconnect the cable from select lever, and then remove the cable bracket.

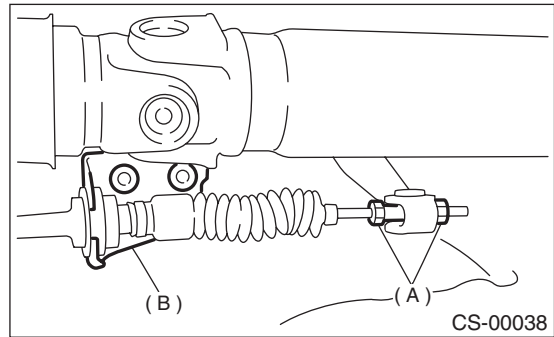

- (A) Adjusting nuts
- (B) Cable bracket

- 11) Remove the select cable from plate assembly.

B: INSTALLATION

- 1) Install the select cable to base plate.

Tightening torque:

18 N·m (1.8 kgf-m, 13.0 ft-lb)

- 2) Install the select cable to range select lever.
- 3) Install the plate assembly to transmission.

Tightening torque:

T: 24.5 N·m (2.5 kgf-m, 18.1 ft-lb)

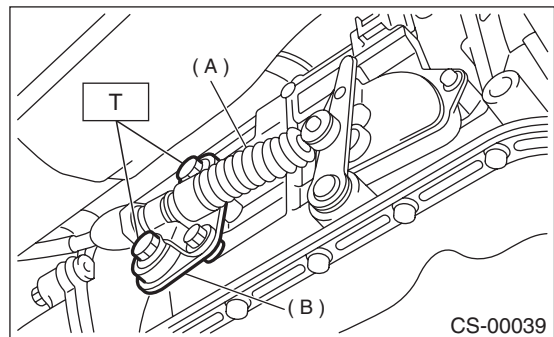

- (A) Select cable
- (B) Plate ASSY

SELECT CABLE

CONTROL SYSTEMS

4) Install the washer and snap pin to range select lever.

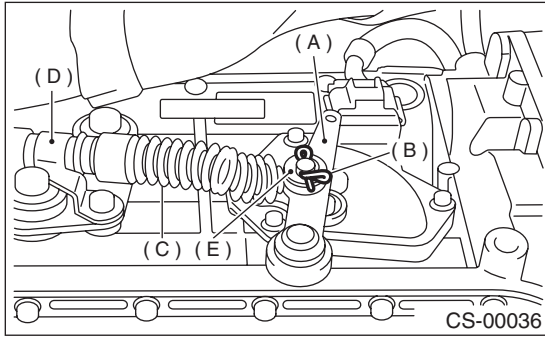

- (A) Range select lever
- (B) Snap pin
- (C) Select cable
- (D) Clamp
- (E) Washer

5) Move the select lever to “N” position, then adjust the select cable position. <Ref. to CS-32, ADJUSTMENT, Select Cable.>

6) Install the heat shield cover. (If equipped)

7) Install the front and center exhaust pipe. (Non-TURBO model)

<Ref. to EX(H4SO)-6, INSTALLATION, Front Exhaust Pipe.>

8) Install center exhaust pipe. (TURBO model)
<Ref. to EX(H4DOTC)-10, INSTALLATION, Center Exhaust Pipe.>

C: INSPECTION

Check the removed cable and replace if damaged, rusty, or malfunctioning.

- 1) Check for smooth operation of the cable.
- 2) Check the inner cable for damage and rust.
- 3) Check the outer cable for damage, bends, and cracks.
- 4) Check the boot for damage, cracks, and deterioration.
- 5) Move the select lever from “P” position to “1” position. You should be able to feel the detentes in each position. If the detentes cannot be felt or the position pointer is improperly aligned, adjust the cable.

D: ADJUSTMENT

- 1) Set the vehicle on a lift.
- 2) Set the lever to “N” position.
- 3) Lift-up the vehicle.
- 4) Remove the rear exhaust pipe and muffler.
- 5) Remove the heat shield cover. (If equipped)

6) Loosen the adjusting nut on each side.

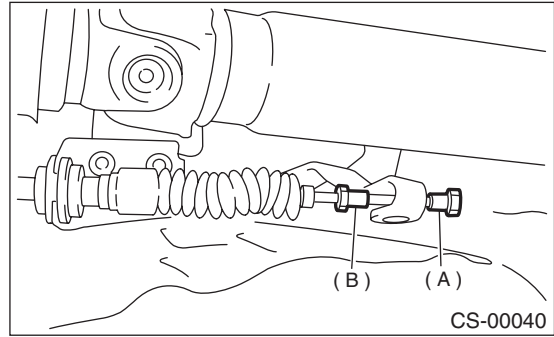

- (A) Adjusting nut A
- (B) Adjusting nut B

7) Turn the adjusting nut B until it lightly touches the connector.

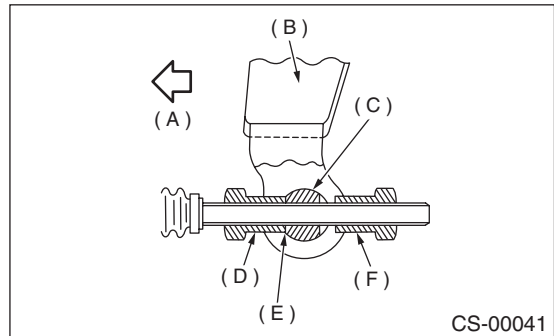

- (A) Front side
- (B) Select lever
- (C) Connector
- (D) Adjusting nut B
- (E) Contact point
- (F) Adjusting nut A

8) While preventing the adjusting nut B from moving with a wrench, tighten the adjusting nut A.

Tightening torque:

7.5 N·m (0.76 kgf·m, 5.5 ft·lb)

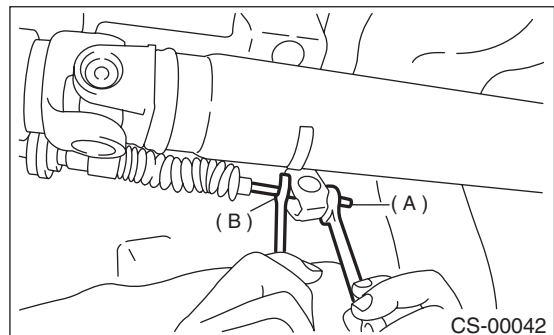

- (A) Adjusting nut A
- (B) Adjusting nut B

- 9) After completion of fitting, make sure that the select lever operates smoothly all across the operating range.
- 10) Install in the reverse order of removal.