

## 8. MT Gear Shift Lever

### A: REMOVAL

- 1) Set the vehicle on a lift.
- 2) Remove the gear shift knob.
- 3) Disconnect the ground cable from battery.
- 4) Remove the console box. <Ref. to EI-36, REMOVAL, Console Box.>
- 5) Remove the clamp.

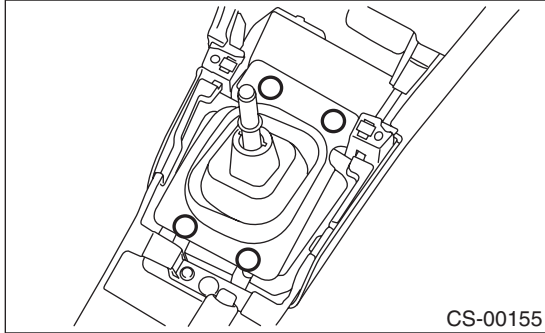

- 6) Remove the boot and insulator assembly.

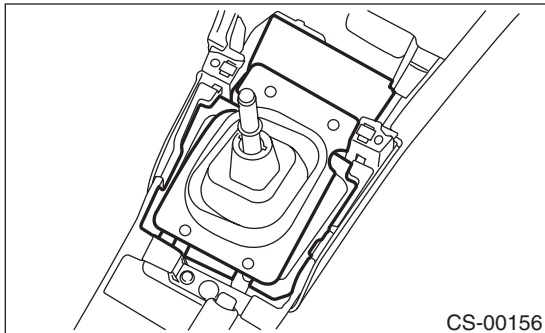

- 7) Remove the plate ASSY from body.

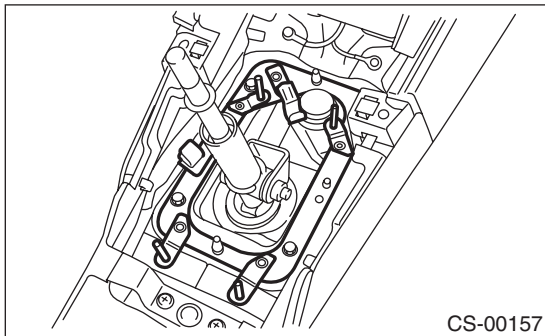

- 8) Lift-up the vehicle.
- 9) Remove the rear exhaust pipe and muffler.  
NON-TURBO model  
<Ref. to EX(H4SO)-9, REMOVAL, Rear Exhaust Pipe.>, <Ref. to EX(H4SO)-10, REMOVAL, Muffler.>  
TURBO model  
<Ref. to EX(H4DOTC)-14, REMOVAL, Rear Exhaust Pipe.>, <Ref. to EX(H4DOTC)-15, REMOVAL, Muffler.>
- 10) Remove the heat shield cover.

- 11) Remove the stay from transmission bracket.

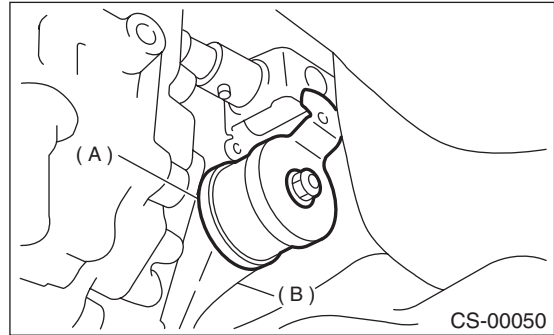

- (A) Stay
- (B) Transmission bracket

- 12) Remove the rod from joint.

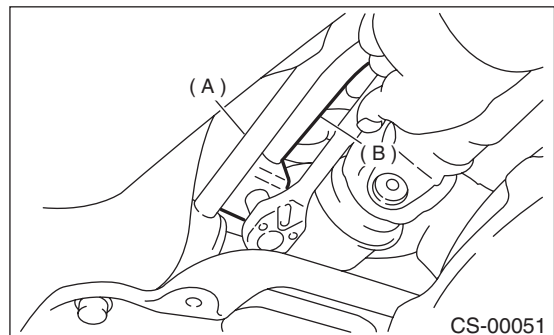

- (A) Stay
- (B) Rod

- 13) Remove the cushion rubber from body.

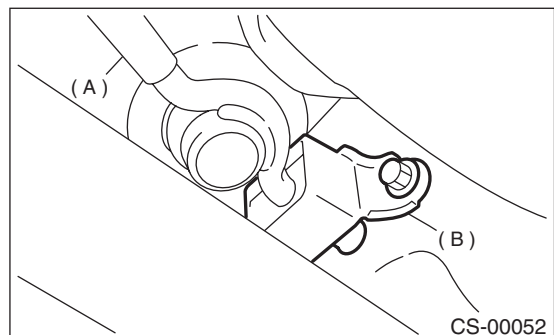

- (A) Stay
- (B) Cushion rubber

14) Remove the spring pin, and then extract the joint.

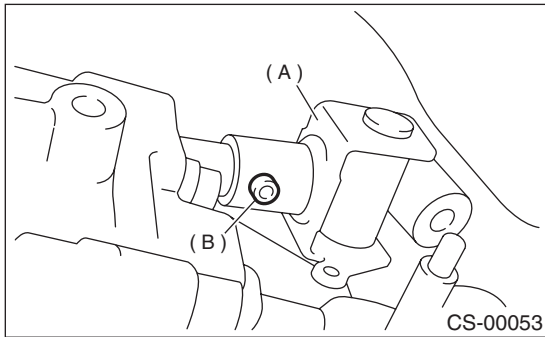

- (A) Joint
- (B) Spring pin

5) Insert the spring pin.

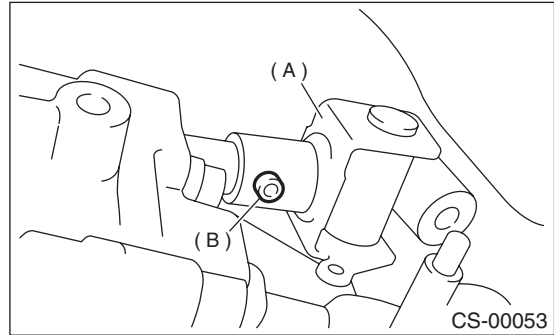

- (A) Joint
- (B) Spring pin

15) Lower the vehicle.

16) Remove the gear shift lever.

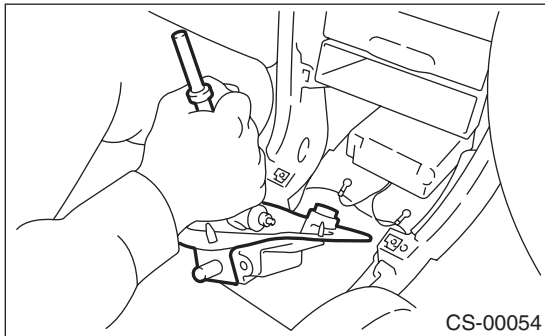

## B: INSTALLATION

1) Install the joint to transmission and secure with the spring pin.

2) Insert the gear shift lever from room side.

### NOTE:

After inserting the rod and stay, temporarily put them onto transmission mount.

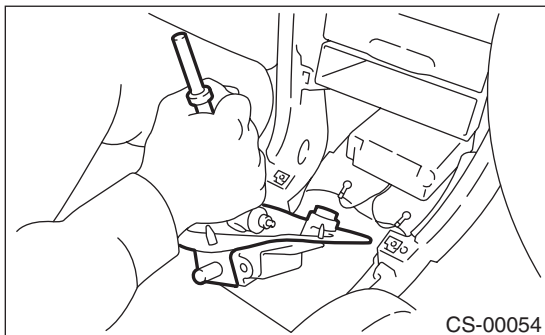

3) Lift-up the vehicle.

4) Install the joint to shifter arm.

6) Mount the cushion rubber on the body.

### **Tightening torque:**

**18 N·m (1.8 kgf-m, 13.0 ft-lb)**

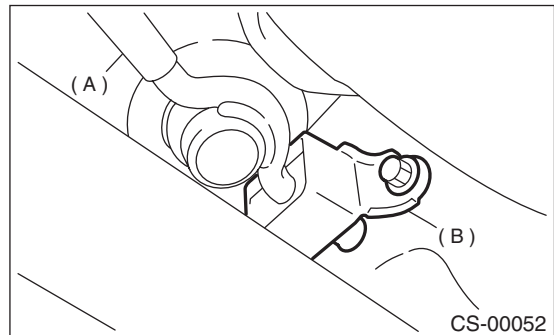

- (A) Stay
- (B) Cushion rubber

7) Connect the rod to the joint.

### **Tightening torque:**

**18 N·m (1.8 kgf-m, 13.0 ft-lb)**

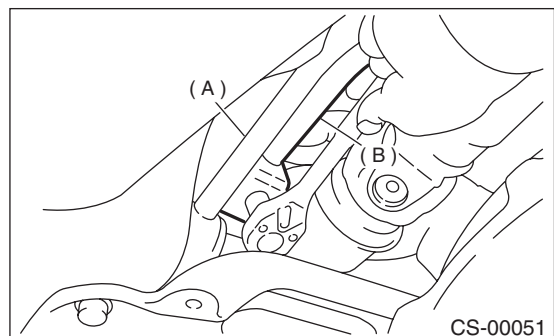

- (A) Stay
- (B) Rod

# MT GEAR SHIFT LEVER

## CONTROL SYSTEMS

8) Connect the stay to transmission bracket.

**Tightening torque:**

**18 N·m (1.8 kgf·m, 13.0 ft·lb)**

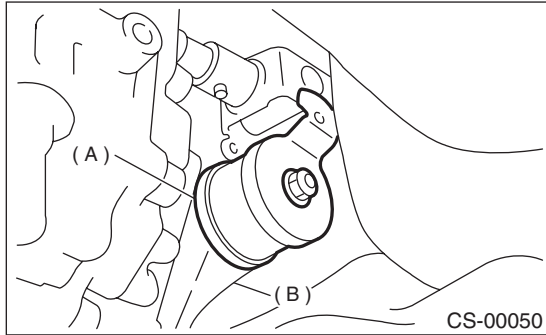

(A) Stay

(B) Transmission bracket

9) Install the heat shield cover. (If equipped)

10) Install the rear exhaust pipe and muffler.

NON-TURBO model

<Ref. to EX(H4SO)-9, INSTALLATION, Rear Exhaust Pipe.>, <Ref. to EX(H4SO)-10, INSTALLATION, Muffler.>

TURBO model

<Ref. to EX(H4DOTC)-14, INSTALLATION, Rear Exhaust Pipe.>, <Ref. to EX(H4DOTC)-15, INSTALLATION, Muffler.>

11) Lower the vehicle.

12) Install the plate ASSY to body.

**Tightening torque:**

**7.5 N·m (0.76 kgf·m, 5.5 ft·lb)**

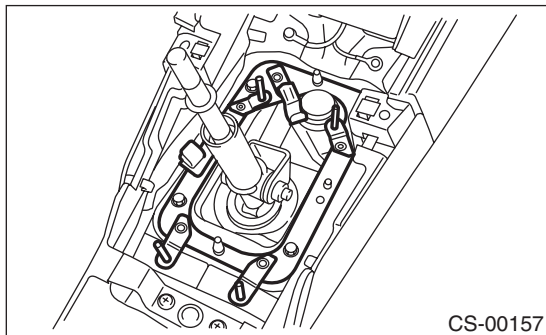

13) Install the boot and insulator assembly to vehicle in proper direction.

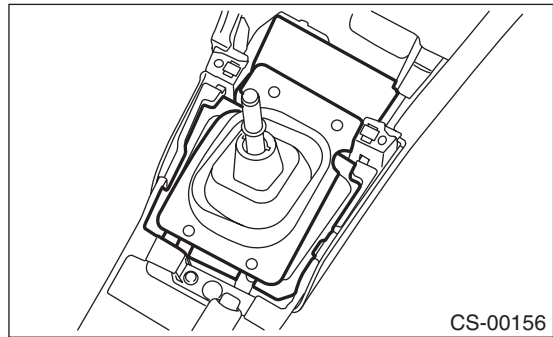

14) Install the clamp.

15) Install the console box. <Ref. to EI-36, INSTALLATION, Console Box.>

## C: DISASSEMBLY

1) Disassemble the lock wire.

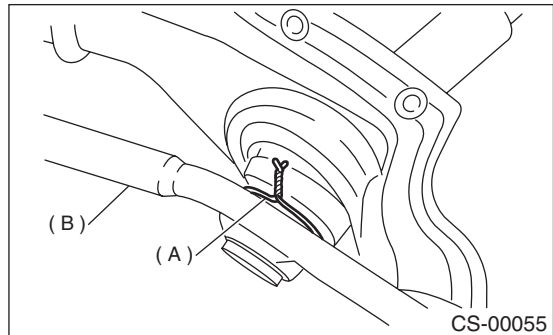

(A) Lock wire

(B) Stay

2) Remove the rod from lever.

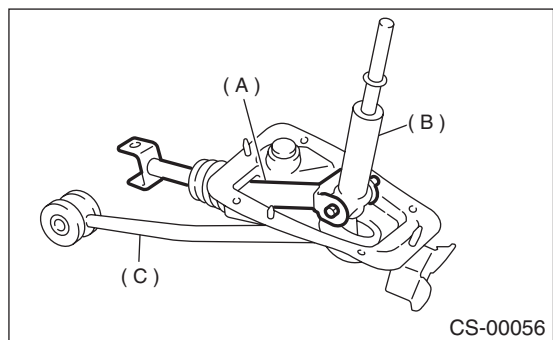

(A) Rod

(B) Lever

(C) Stay

3) Remove the snap ring from bushing B, and then disconnect the stay.

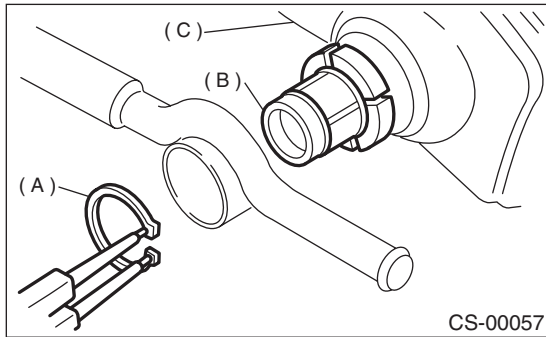

- (A) Snap ring
- (B) Bushing B
- (C) Boot

4) Remove the boot from gear shift lever.  
5) Remove the bushing and cushion rubber from stay.

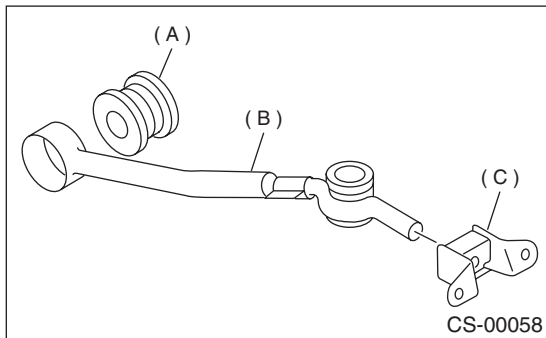

- (A) Bushing
- (B) Stay
- (C) Cushion rubber

6) Remove the O-ring, and then disconnect the bushing B.

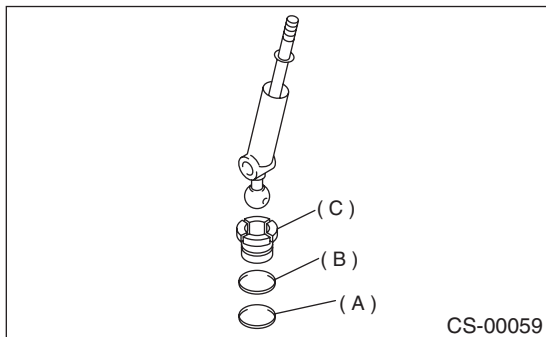

- (A) O-ring
- (B) O-ring
- (C) Bushing B

7) Draw out the spring pin, and then remove the bushing A from gear shift lever.

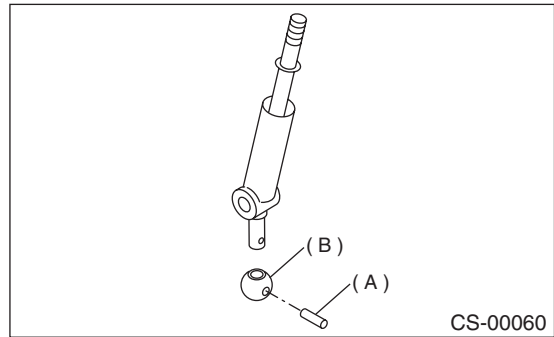

- (A) Spring pin
- (B) Bushing A

## D: ASSEMBLY

1) Clean all parts before assembly.  
2) Mount the bushing and cushion rubber on the stay.

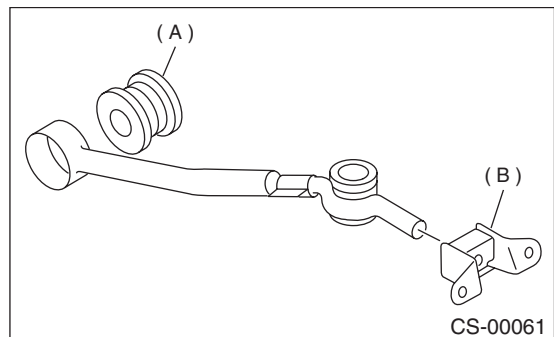

- (A) Bushing
- (B) Cushion rubber

# MT GEAR SHIFT LEVER

## CONTROL SYSTEMS

3) Mount each part; boot, O-ring, bushing A, spacer, bushing B, bushing and spring pin on the gear shift lever.

### NOTE:

- Always use new O-rings.
- Apply grease [KOPR-KOTE (Part No. 003603001) or equivalent] to the inner and side surfaces of the bushing when installing the spacer.

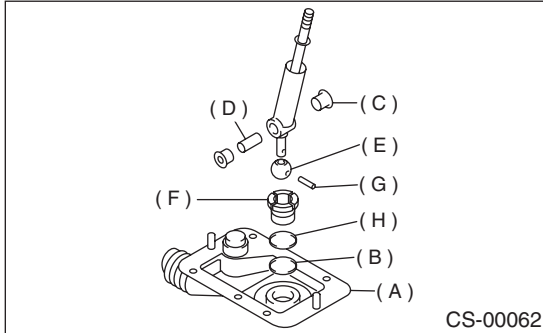

- (A) Boot
- (B) O-ring
- (C) Bushing
- (D) Spacer
- (E) Bushing A
- (F) Bushing B
- (G) Spring pin
- (H) O-ring

4) Insert the gear shift lever into boot hole.  
5) Install the snap ring and stay to bushing B.

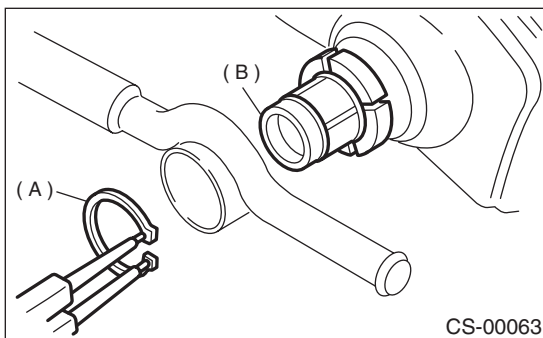

- (A) Snap ring
- (B) Bushing B

6) Tighten with a new lock wire to the extent that the boot will not come off.

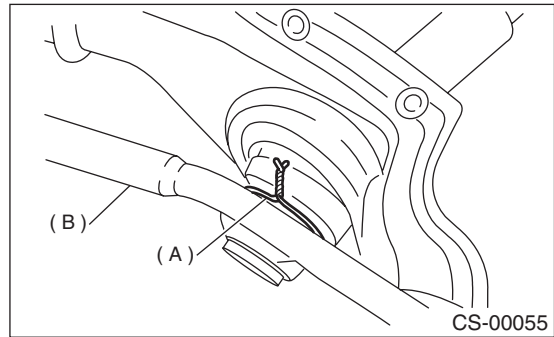

- (A) Lock wire
- (B) Stay

7) Insert the rod into boot hole.  
8) Connect the rod to gear shift lever.

### Tightening torque:

**11.8 N-m (1.2 kgf-m, 8.7 ft-lb)**

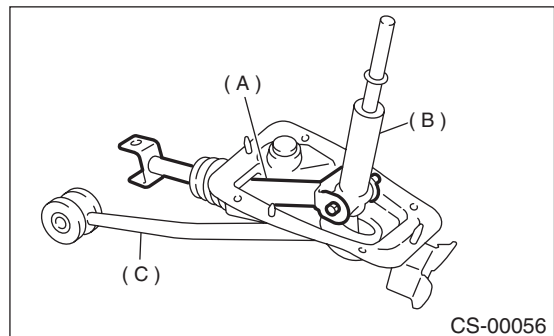

- (A) Rod
- (B) Lever
- (C) Stay

9) Check the swing torque of the rod in relation to gear shift lever.  
10) Check that there is no excessive play and that parts move smoothly.

## E: INSPECTION

1) Check each part (bushing, cushion rubber, spacer, boot, stay and rod, etc.) for deformation, damage and wear. Repair or replace any defective part. Determine defective parts by comparing with new parts.

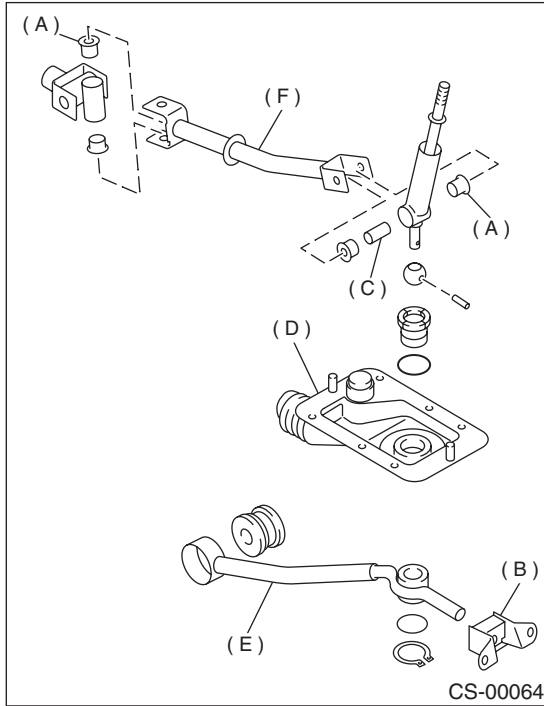

- (A) Bushing
- (B) Cushion rubber
- (C) Spacer
- (D) Boot
- (E) Stay
- (F) Rod

2) Check the swing torque of the rod in relation of gear shift lever.  
If the torque exceeds specification, replace the bushing or retighten nuts.

### Swing torque:

**3.7 N (0.38 kgf, 0.84 lb) or less**

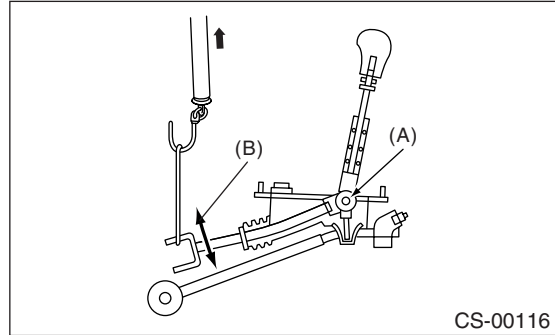

- (A) Center of rotation
- (B) Swing torque