

TRANSFER DRIVE GEAR

MANUAL TRANSMISSION AND DIFFERENTIAL

11. Transfer Drive Gear

A: REMOVAL

- 1) Remove the manual transmission assembly from vehicle. <Ref. to 5MT-27, REMOVAL, Manual Transmission Assembly.>
- 2) Remove the back-up light switch and neutral position switch. <Ref. to 5MT-37, REMOVAL, Switches and Harness.>
- 3) Remove the transfer case with extension case assembly. <Ref. to 5MT-41, REMOVAL, Transfer Case and Extension Case Assembly.>
- 4) Remove the extension case assembly.
- 5) Remove the transfer driven gear.
- 6) Remove the transfer drive gear.

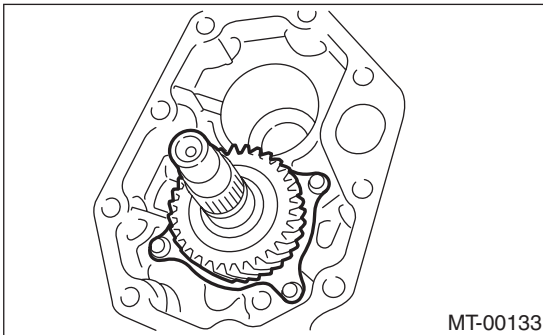

B: INSTALLATION

- 1) Install the transfer drive gear.

Tightening torque:

26 N·m (2.7 kgf·m, 20 ft·lb)

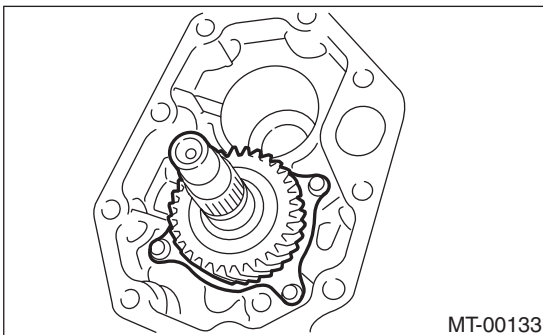

- 2) Install the transfer driven gear.
- 3) Install the extension case assembly.
- 4) Install the transfer case and extension case assembly. <Ref. to 5MT-41, INSTALLATION, Transfer Case and Extension Case Assembly.>
- 5) Install the back-up light switch and neutral position switch. <Ref. to 5MT-37, INSTALLATION, Switches and Harness.>
- 6) Install the manual transmission assembly from vehicle. <Ref. to 5MT-30, INSTALLATION, Manual Transmission Assembly.>

C: DISASSEMBLY

- 1) Remove the snap ring.

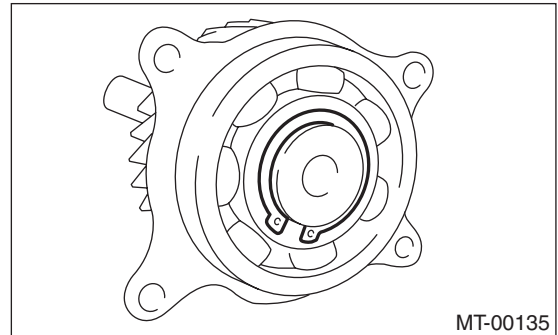

- 2) Remove the ball bearing.

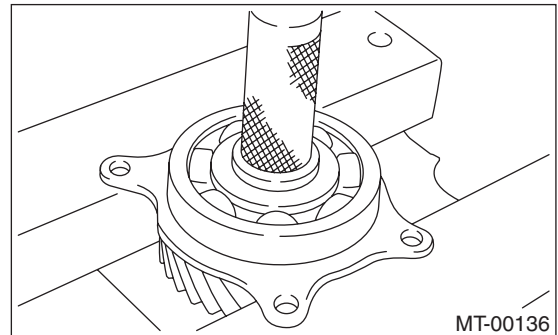

D: ASSEMBLY

- 1) Set the ST applying to inner race of bearing and install to drive shaft.

ST 398177700 INSTALLER

NOTE:

Do not apply pressure in excess of 10 kN (1 ton, 1.1 US ton, 1.0 Imp ton)

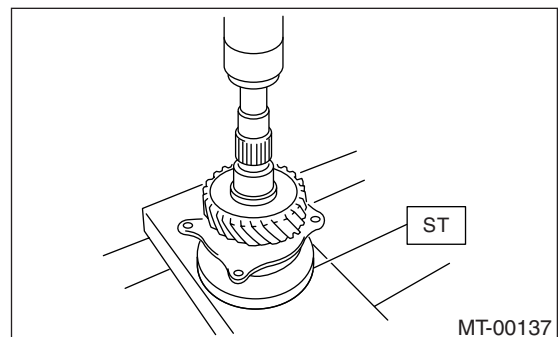

- 2) Install the snap ring on transfer drive shaft.
- 3) Check the clearance between snap ring and ball bearing. <Ref. to 5MT-46, INSPECTION, Transfer Drive Gear.>

TRANSFER DRIVE GEAR

MANUAL TRANSMISSION AND DIFFERENTIAL

E: INSPECTION

1) Bearings

Replace the bearings in the following cases:

- Broken or rusty bearings
- Worn or damaged
- Bearings that fail to turn smoothly or make abnormal noise when turned after gear oil lubrication.

2) Drive gear

Replace the drive gear in the following cases:

- If their tooth surfaces and shaft are excessively broken or damaged.

3) Measure the clearance between snap ring and inner race of ball bearing with a thickness gauge.

Clearance:

0.01 — 0.15 mm (0.0004 — 0.0059 in)

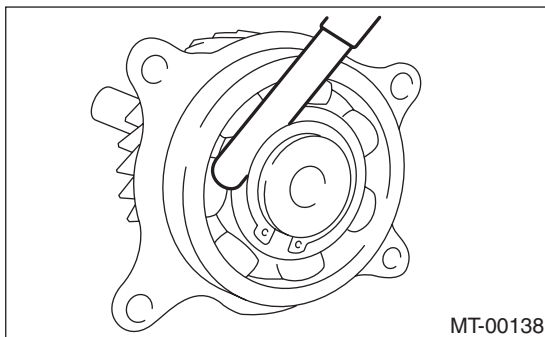

If the measurement is not within specification, select a suitable snap ring.

Snap ring (Outer-30)	
Part No.	Thickness mm (in)
805030041	1.53 (0.0602)
805030042	1.65 (0.0650)
805030043	1.77 (0.0697)