

TRANSMISSION CASE

MANUAL TRANSMISSION AND DIFFERENTIAL

15. Transmission Case

A: REMOVAL

- 1) Remove the manual transmission assembly from vehicle. <Ref. to 5MT-27, REMOVAL, Manual Transmission Assembly.>
- 2) Remove the clutch release lever. <Ref. to CL-15, REMOVAL, Release Bearing and Lever.>
- 3) Remove the transfer case with extension case assembly. <Ref. to 5MT-41, REMOVAL, Transfer Case and Extension Case Assembly.>
- 4) Remove the bearing mounting bolts.

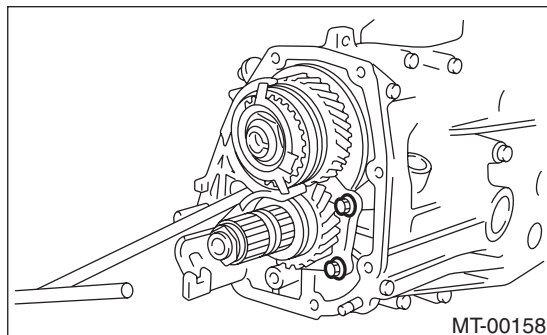

- 5) Remove the main shaft rear plate.

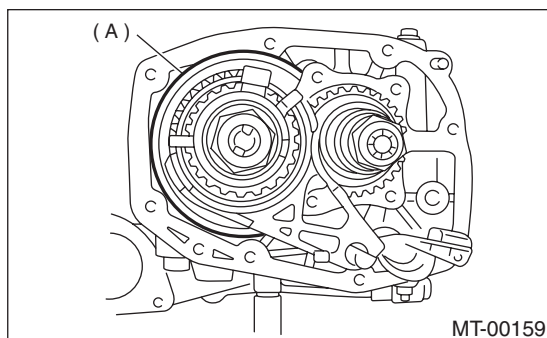

(A) Main shaft rear plate

- 6) Put vinyl tape around the splines of right and left axle drive shafts to prevent damage to oil seal. (Non-TURBO model)

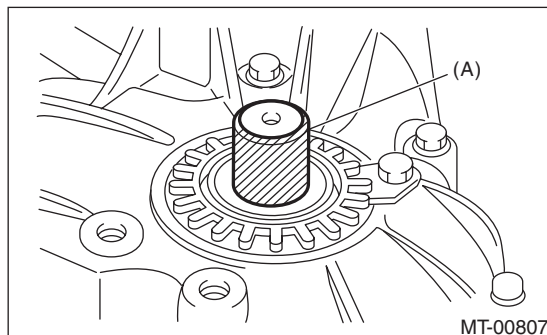

(A) Vinyl tape

- 7) Separate the transmission case into right and left cases by loosening the coupling bolts and nuts.

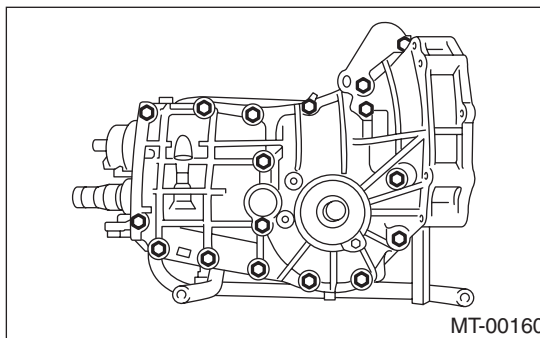

- 8) Remove the drive pinion shaft assembly from left side transmission case.

NOTE:

Use a hammer handle, etc. to remove if too tight.

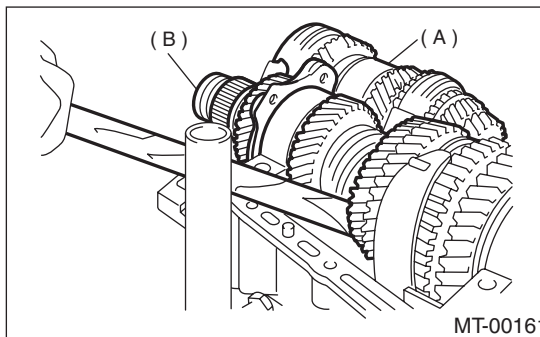

(A) Main shaft assembly

(B) Drive pinion shaft assembly

- 9) Remove the main shaft assembly.
- 10) Remove the differential assembly.

NOTE:

- Be careful not to confuse the right and left roller bearing outer races.
- Be careful not to damage the retainer oil seal.

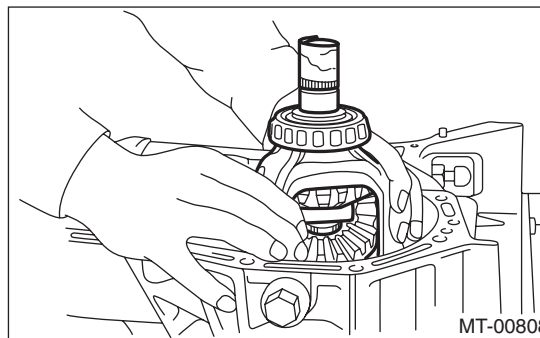

TRANSMISSION CASE

MANUAL TRANSMISSION AND DIFFERENTIAL

B: INSTALLATION

- 1) Wipe off grease, oil and dust on the mating surfaces of transmission cases with white gasoline.
- 2) Install the front differential assembly.
- 3) Install the main shaft assembly.
Install the transmission case knock pin into needle bearing knock pin hole.
- 4) Install the drive pinion shaft assembly.
Install the transmission case knock pin into roller bearing knock pin hole.
- 5) Apply liquid gasket, and then put the case right side and left side together.

Liquid gasket:

THREE BOND 1215 (Part No. 004403007) or equivalent

- 6) Tighten the seventeen bolts with bracket, clip, etc. as shown in the figure.

NOTE:

- Insert the bolts from bottom and tighten the nuts at top.
- Put the cases together so that drive pinion shim and input shaft holder shim are not caught up in between.
- Confirm that the speedometer gear is meshed.

Tightening torque:

8 mm bolt

25 N·m (2.5 kgf·m, 18.1 ft·lb)

★ 10 mm bolt

39 N·m (4.0 kgf·m, 28.9 ft·lb)

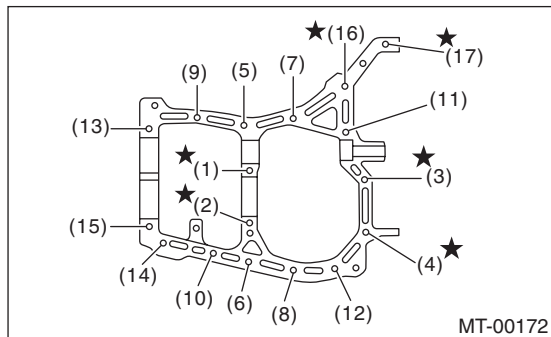

- 7) Tighten the ball bearing attachment bolts.

Tightening torque:

29 N·m (3.0 kgf·m, 21.7 ft·lb)

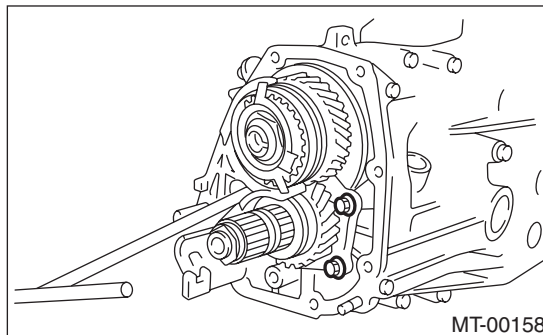

- 8) Backlash adjustment of hypoid gear and preload adjustment of roller bearing:

NOTE:

Support the drive pinion assembly with ST.

ST 498427100 STOPPER

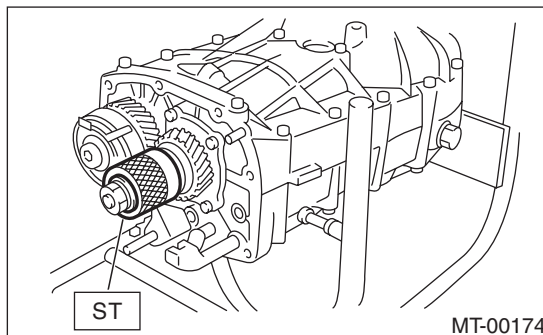

- 9) Place the transmission with case left side facing downward and put ST1 on bearing cup.

- 10) Screw the retainer assembly into left case from the bottom using ST2. Fit the ST3 on transmission main shaft. Shift the gear into 4th or 5th and turn the shaft several times. Screw in the retainer while turning ST3 until a slight resistance is felt on ST2. This is the contact point of hypoid gear and drive pinion shaft. Repeat the above sequence several times to ensure the contact point.

ST1 399780104 WEIGHT

ST2 499787000 WRENCH ASSY

ST3 499927100 HANDLE

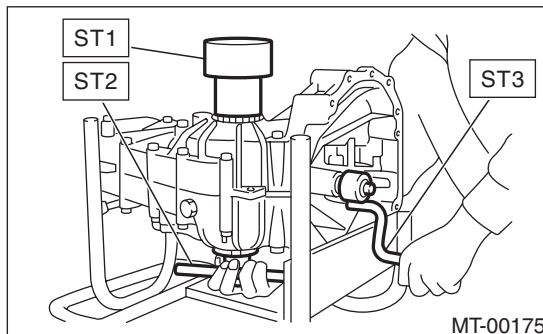

TRANSMISSION CASE

MANUAL TRANSMISSION AND DIFFERENTIAL

11) Remove the weight and screw in the retainer without O-ring on upper side and stop at the point where slight resistance is felt.

NOTE:

At this point, the backlash between hypoid gear and drive pinion shaft is zero.

ST 499787000 WRENCH ASSY

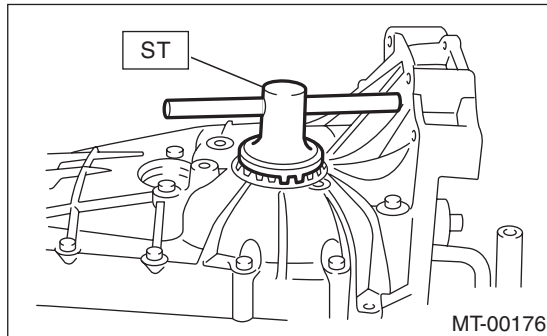

12) Loosen the retainer on the lower side by 3 notches and turn in the retainer on upper side by the same amount in order to obtain the backlash.

13) Turn in the retainer on the upper side additionally by 1 notch in order to apply preload on taper roller bearing.

14) Install temporarily both the upper and lower lock plates and mark both holder and lock plate for later readjustment.

NOTE:

Install the lock plate upside down if it is hard to install.

15) Turn the transmission main shaft several times while tapping around the retainer lightly with plastic hammer.

16) Inspect and adjust the backlash and tooth contact of hypoid gear. <Ref. to 5MT-74, INSPECTION, Front Differential Assembly.>

17) After checking the tooth contact of hypoid gears, remove the lock plate. Then loosen the retainer until the O-ring groove appears. Fit the O-ring into groove and tighten the retainer to the original position.

Install the lock plate.

NOTE:

Record how many times the retainer is turned while loosening.

Carry out this job on both upper and lower retainers.

Tightening torque:

T: 25 N·m (2.5 kgf-m, 18.1 ft-lb)

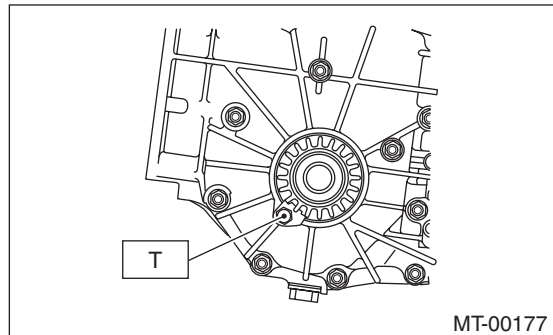

18) Selecting of main shaft rear plate. <Ref. to 5MT-61, ADJUSTMENT, Main Shaft Assembly.>

19) Install the clutch release lever and bearing. <Ref. to CL-15, INSTALLATION, Release Bearing and Lever.>

20) Install the transfer case with extension case assembly. <Ref. to 5MT-41, INSTALLATION, Transfer Case and Extension Case Assembly.>

21) Install the manual transmission assembly into the vehicle. <Ref. to 5MT-30, INSTALLATION, Manual Transmission Assembly.>

C: INSPECTION

Check the transmission case for cracks, damage, and oil leaks.