

# FRONT DIFFERENTIAL ASSEMBLY

## MANUAL TRANSMISSION AND DIFFERENTIAL

### 18. Front Differential Assembly

#### A: REMOVAL

- 1) Remove the manual transmission assembly from vehicle. <Ref. to 5MT-27, REMOVAL, Manual Transmission Assembly.>
- 2) Remove the transfer case with extension case assembly. <Ref. to 5MT-41, REMOVAL, Transfer Case and Extension Case Assembly.>
- 3) Remove the transmission case. <Ref. to 5MT-53, REMOVAL, Transmission Case.>
- 4) Remove the drive pinion shaft assembly. <Ref. to 5MT-62, REMOVAL, Drive Pinion Shaft Assembly.>
- 5) Remove the main shaft assembly. <Ref. to 5MT-56, REMOVAL, Main Shaft Assembly.>
- 6) Remove the differential assembly.

#### NOTE:

- Be careful not to confuse the right and left roller bearing outer races.
- Be careful not to damage the retainer oil seal.

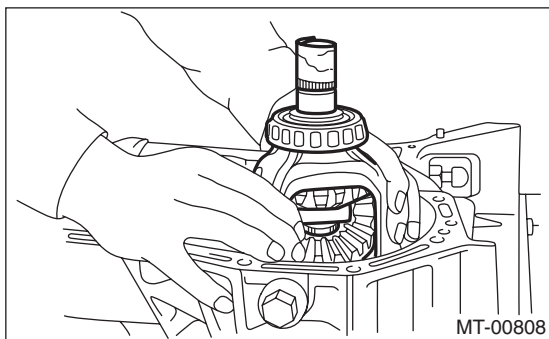

- 7) Remove the differential side retainers using ST. ST 499787000 WRENCH ASSY

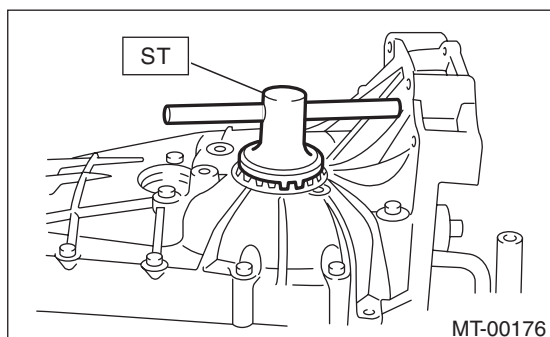

#### B: INSTALLATION

- 1) Install the differential side retainers using ST. ST 499787000 WRENCH ASSY
- 2) Install the bearing outer race to transmission case.
- 3) Install the differential assembly.

#### NOTE:

- Be careful not to fold the sealing lip of oil seal.
- Wrap the right and left spline sections of axle shaft with vinyl tape to prevent scratches.

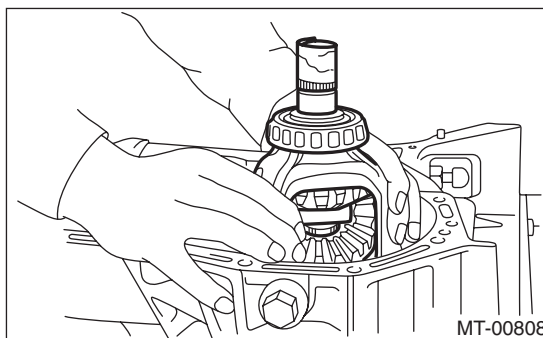

- 4) Install the main shaft assembly. <Ref. to 5MT-56, INSTALLATION, Main Shaft Assembly.>
- 5) Install the drive pinion assembly. <Ref. to 5MT-62, INSTALLATION, Drive Pinion Shaft Assembly.>
- 6) Install the transmission case. <Ref. to 5MT-54, INSTALLATION, Transmission Case.>
- 7) Install the transfer case with extension case assembly. <Ref. to 5MT-41, INSTALLATION, Transfer Case and Extension Case Assembly.>
- 8) Install the manual transmission assembly to vehicle. <Ref. to 5MT-30, INSTALLATION, Manual Transmission Assembly.>

#### C: DISASSEMBLY

##### 1. DIFFERENTIAL CASE ASSEMBLY

- 1) Remove the right and left snap rings from differential, and then remove the two axle drive shafts. (Non-TURBO model)

#### NOTE:

During reassembly, reinstall each axle drive shaft in the same place from which it was removed.

# FRONT DIFFERENTIAL ASSEMBLY

## MANUAL TRANSMISSION AND DIFFERENTIAL

2) Loosen the twelve bolts and remove the hypoid driven gear.

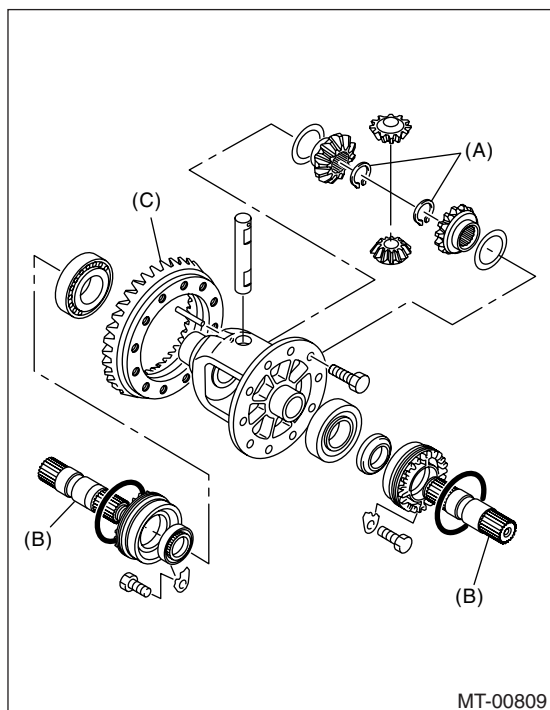

- (A) Snap ring (Non-TURBO model)
- (B) Axle drive shaft (Non-TURBO model)
- (C) Hypoid driven gear

3) Drive out the straight pin from differential assembly toward hypoid driven gear.

ST 899904100 REMOVER

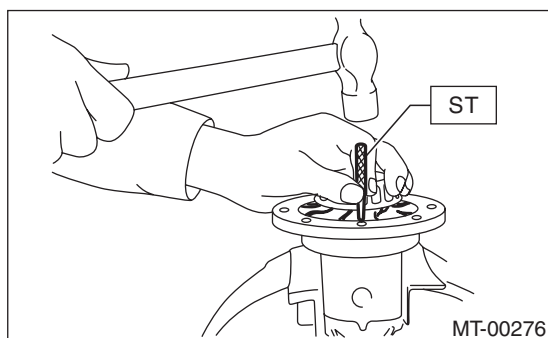

4) Pull out the pinion shaft, and remove the differential bevel pinion and gear and washer.

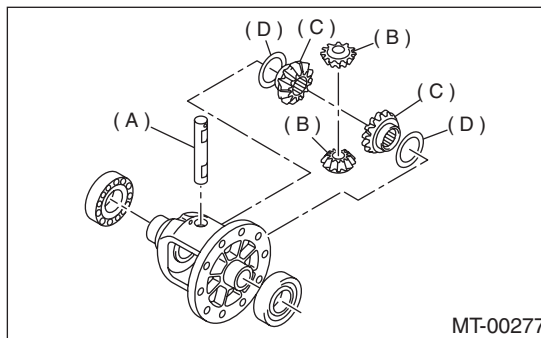

- (A) Pinion shaft
- (B) Bevel pinion
- (C) Bevel gear
- (D) Washer

5) Remove the roller bearing using ST.

ST 899524100 PULLER SET

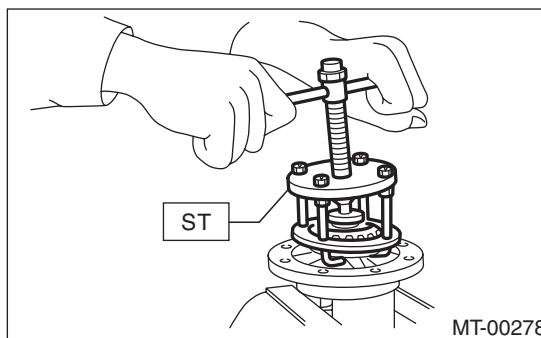

## 2. SIDE RETAINER

1) Remove the O-ring.

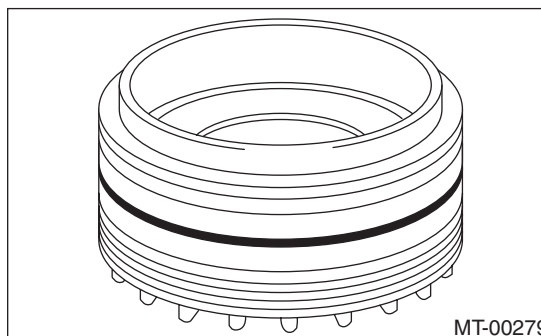

# FRONT DIFFERENTIAL ASSEMBLY

## MANUAL TRANSMISSION AND DIFFERENTIAL

2) Remove the oil seal.

NOTE:

Do not reuse the oil seal. Prepare a new oil seal.

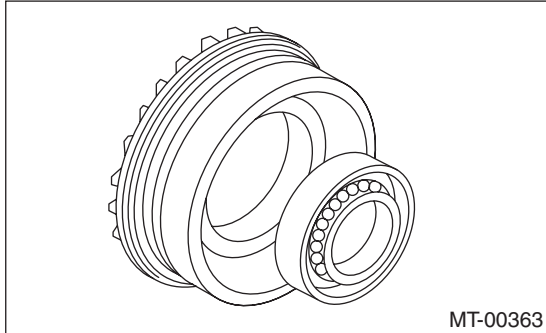

## D: ASSEMBLY

### 1. DIFFERENTIAL CASE ASSEMBLY

1) Install the bevel gear and bevel pinion together with washers, and insert pinion shaft.

NOTE:

Face the chamfered side of washer toward gear.

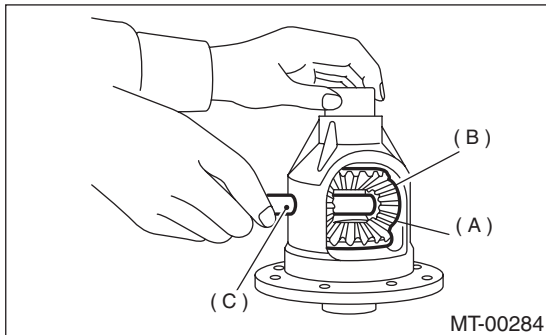

- (A) Bevel pinion
- (B) Bevel gear
- (C) Pinion shaft

2) Measure the backlash between bevel gear and pinion. If it is not within specifications, install a suitable washer to adjust it. <Ref. to 5MT-75, ADJUSTMENT, Front Differential Assembly.>

NOTE:

Be sure the pinion gear tooth contacts adjacent gear teeth during measurement.

- ST1 498247001 MAGNET BASE
- ST2 498247100 DIAL GAUGE

**Standard backlash:**

**0.13 — 0.18 mm (0.0051 — 0.0071 in)**

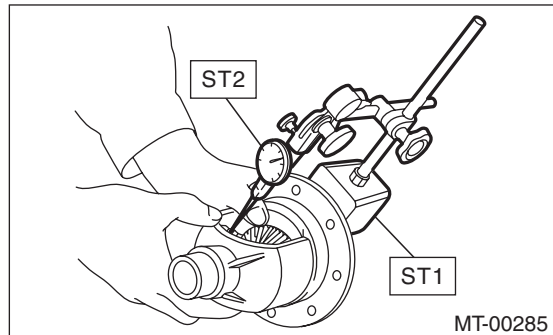

3) Align the pinion shaft and differential case at their holes, and drive the straight pin into holes from the hypoid driven gear side, using ST.

NOTE:

Lock the straight pin after installing.

ST 899904100 REMOVER

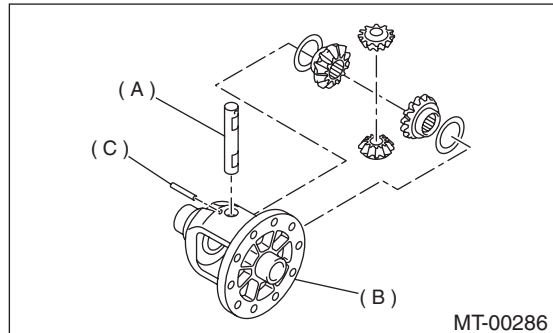

- (A) Pinion shaft
- (B) Differential case
- (C) Straight pin

4) Install the roller bearing to differential case.

NOTE:

- Do not apply pressure in excess of 10 kN (1 ton, 1.1 US ton, 1.0 Imp ton).
- Be careful because the roller bearing outer races are used as a set.

ST1 499277100 BUSH 1-2 INSTALLER

ST2 398497701 ADAPTER

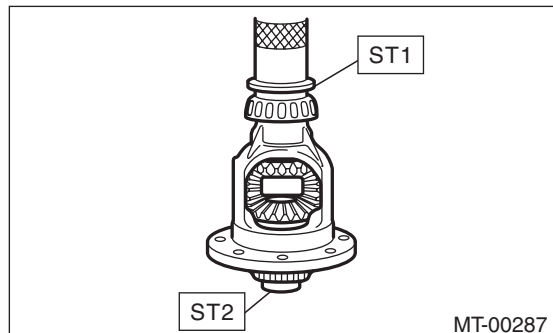

# FRONT DIFFERENTIAL ASSEMBLY

MANUAL TRANSMISSION AND DIFFERENTIAL

5) Install the hypoid driven gear to differential case using twelve bolts.

**Tightening torque:**

**T: 62 N·m (6.3 kgf·m, 45.6 ft·lb)**

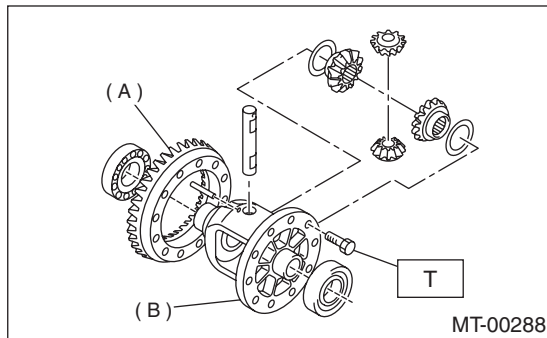

- (A) Hypoid driven gear
- (B) Differential case

6) Set the drive axle shaft into differential case and hold it using outer spring. Measure the shaft to case clearance to check if it is within specifications using thickness gauge. (Non-TURBO model)

**NOTE:**

Replace the snap ring with suitable one, if the measurement is not within specifications.

Snap ring (Outer)	
Part No.	Thickness mm (in)
805028011	1.05 (0.0413)
805028012	1.20 (0.0472)

**Clearance**

**0 — 0.2 mm (0 — 0.008 in)**

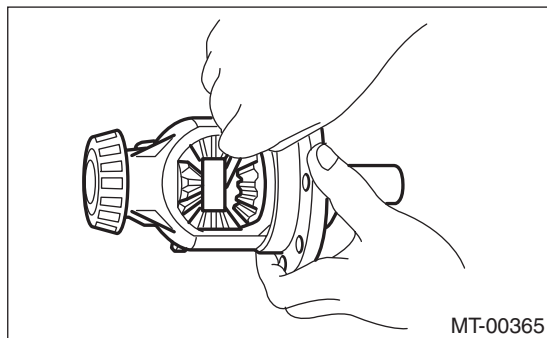

## 2. SIDE RETAINER

1) Install a new oil seal. (Non-TURBO model)

ST 49979700 INSTALLER

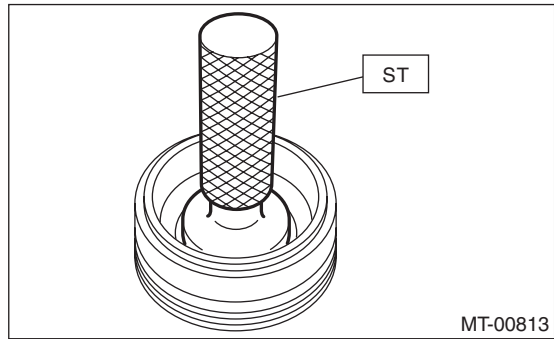

2) Install a new oil seal. (TURBO model)

ST 18675AA000 DIFFERENTIAL OIL SEAL INSTALLER

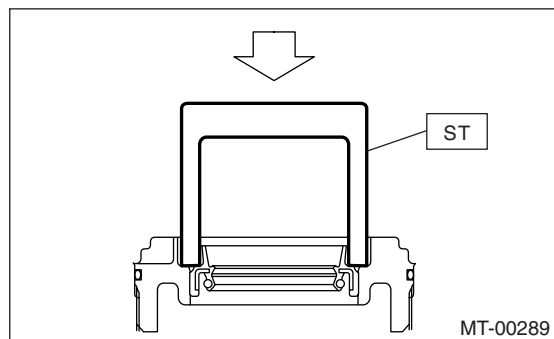

3) Install a new O-ring.

**NOTE:**

Do not stretch or damage the O-ring.

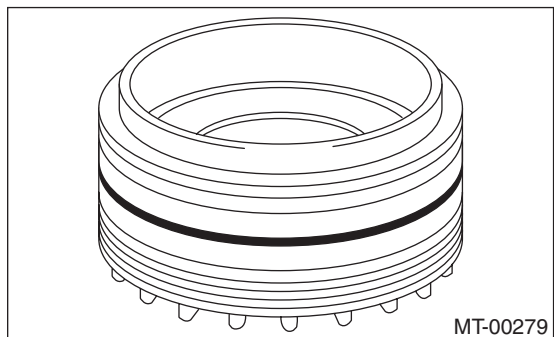

# FRONT DIFFERENTIAL ASSEMBLY

## MANUAL TRANSMISSION AND DIFFERENTIAL

### E: INSPECTION

Repair or replace the differential gear in the following cases:

- The hypoid drive gear and drive pinion shaft tooth surface are damaged, excessively worn, or seized.
- The roller bearing on the drive pinion shaft has a worn or damaged roller path.
- There is damage, wear, or seizure of the differential bevel pinion, differential bevel gear, washer, pinion shaft, and straight pin.
- The differential case has worn or damaged sliding surfaces.

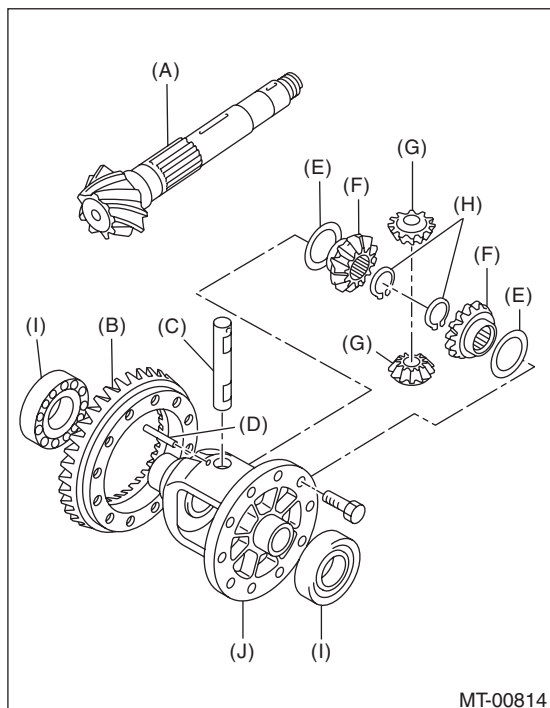

- (A) Drive pinion shaft
- (B) Hypoid driven gear
- (C) Pinion shaft
- (D) Straight pin
- (E) Washer
- (F) Differential bevel gear
- (G) Differential bevel pinion
- (H) Snap ring
- (I) Roller bearing
- (J) Differential case

### 1. BEVEL PINION GEAR BACKLASH

Measure the backlash between bevel gear and pinion. If it is not within specifications, install a suitable washer to adjust it.

#### NOTE:

Be sure the pinion gear tooth contacts adjacent gear teeth during measurement.

- ST1 498247001 MAGNET BASE
- ST2 498247100 DIAL GAUGE

#### Standard backlash:

**0.13 — 0.18 mm (0.0051 — 0.0071 in)**

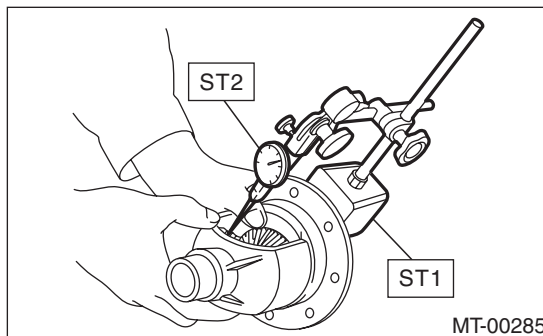

### 2. HYPOID GEAR BACKLASH

1) Insert the SUBARU genuine axle shaft into the left and right side retainer holes. (TURBO model)

ST 38415AA000 AXLE SHAFT

2) Set the ST1, ST2 and ST3. Insert the needle through transmission oil drain plug hole so that the needle comes in contact with the tooth surface at a right angle and check the backlash.

ST1 498247001 MAGNET BASE

ST2 498247100 DIAL GAUGE

ST3 498255400 PLATE

#### Backlash:

**0.13 — 0.18 mm (0.0051 — 0.0071 in)**

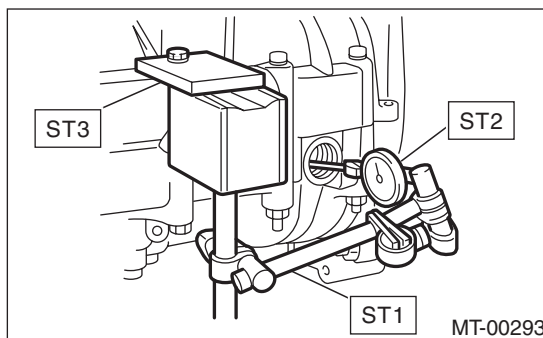

#### NOTE:

If the backlash is outside specified range, adjust it by turning the holder in right side case.

# FRONT DIFFERENTIAL ASSEMBLY

MANUAL TRANSMISSION AND DIFFERENTIAL

## 3. TOOTH CONTACT OF HYPOID GEAR

Check the tooth contact of hypoid gear as follows: Apply a uniform thin coat of red lead on both tooth surfaces of 3 or 4 teeth of the hypoid gear. Move the hypoid gear back and forth by turning the transmission main shaft until a definite contact pattern is developed on hypoid gear, and judge whether face contact is correct. If it is inaccurate, make adjustment. <Ref. to 5MT-75, ADJUSTMENT, Front Differential Assembly.>

- Tooth contact is correct.

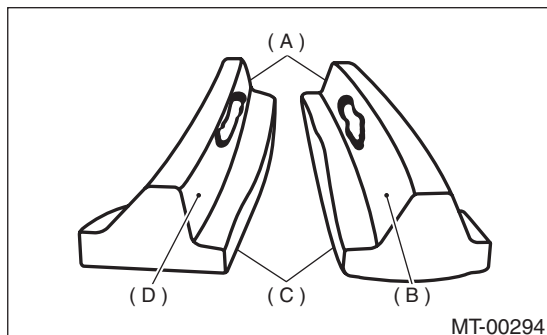

- (A) Toe
- (B) Coast side
- (C) Heel
- (D) Drive side

## F: ADJUSTMENT

### 1. BEVEL PINION GEAR BACKLASH

- 1) Disassemble the front differential. <Ref. to 5MT-70, REMOVAL, Front Differential Assembly.>
- 2) Select a differential washer from the table and install.

Washer	
Part No.	Thickness mm (in)
803038021	0.925 — 0.950 (0.0364 — 0.0374)
803038022	0.975 — 1.000 (0.0384 — 0.0394)
803038023	1.025 — 1.050 (0.0404 — 0.0413)

- 3) Adjust until the specified value is obtained.

#### Standard backlash:

**0.13 — 0.18 mm (0.0051 — 0.0071 in)**

### 2. HYPOID GEAR BACKLASH

Adjust backlash by turning the holder in right side case.

ST 499787000 WRENCH ASSY

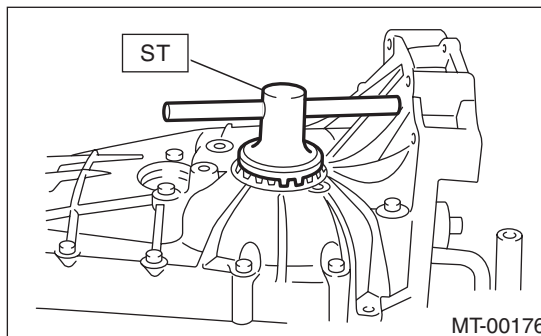

#### NOTE:

Each time holder rotates one tooth, backlash changes by 0.05 mm (0.0020 in).

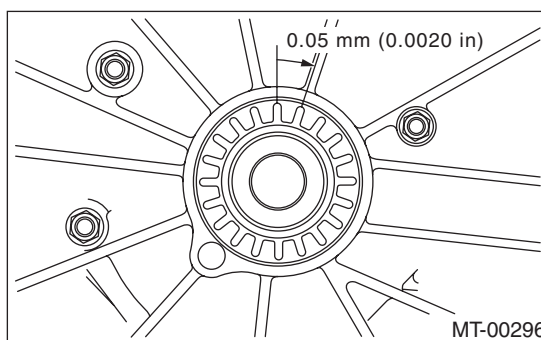

## 3. TOOTH CONTACT OF HYPOID GEAR

- 1) Adjust until the tooth contact is correct.
- 2) Check and adjust the tooth contact with following.

- Tooth contact

**Checking item: Tooth contact pattern is slightly shifted toward to toe side under no-load rotation. [When loaded, contact pattern moves toward heel.]**

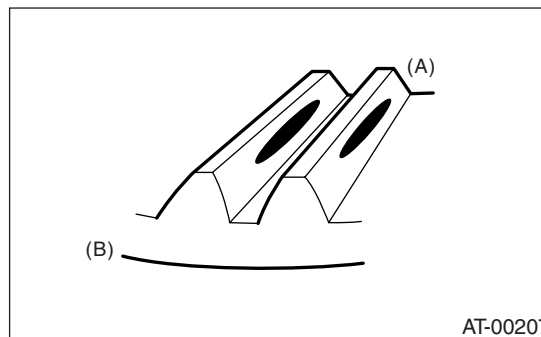

- (A) Toe side
- (B) Heel side

# FRONT DIFFERENTIAL ASSEMBLY

## MANUAL TRANSMISSION AND DIFFERENTIAL

- Face contact

**Checking item: Backlash is too large.**

Contact pattern

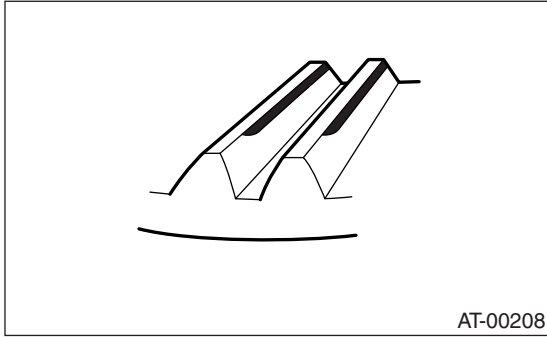

Corrective action: Reduce thickness of drive pinion shim in order to bring drive pinion close to driven gear.

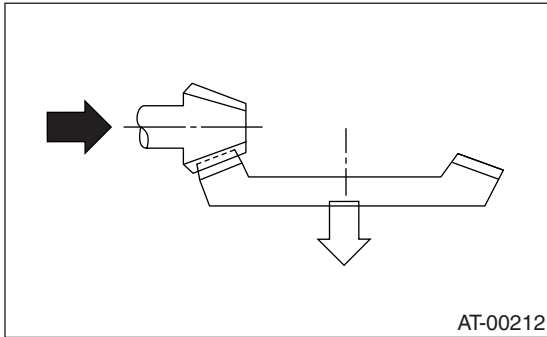

- Flank contact

**Checking item: Backlash is too small.**

Contact pattern

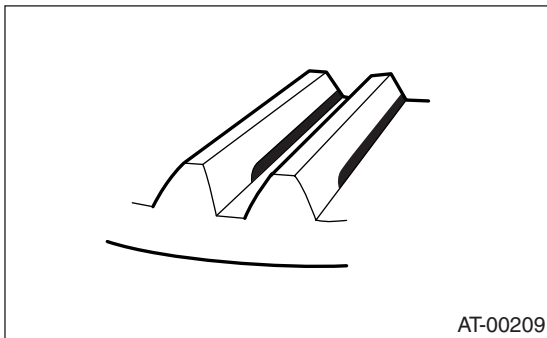

Corrective action: Increase thickness of drive pinion shim in order to move drive pinion away from driven gear.

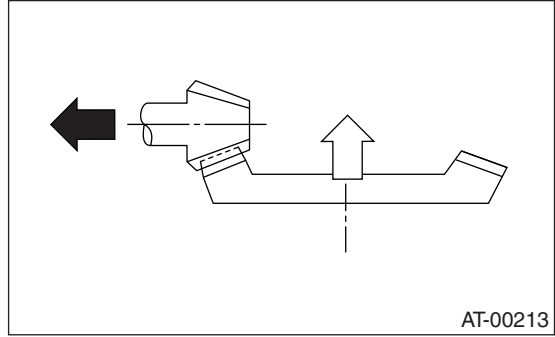

- Toe contact (Inside end contact)

**Checking item: Contact area is small.**

Contact pattern

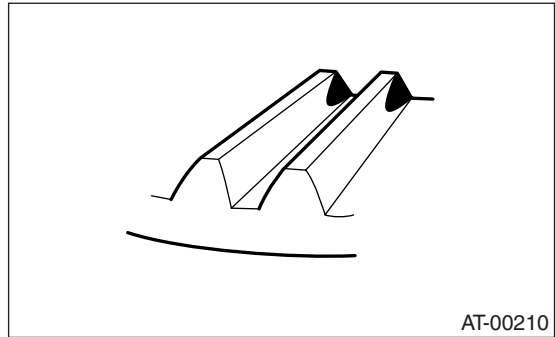

Corrective action: Increase thickness of drive pinion shim in order to bring drive pinion close to driven gear.

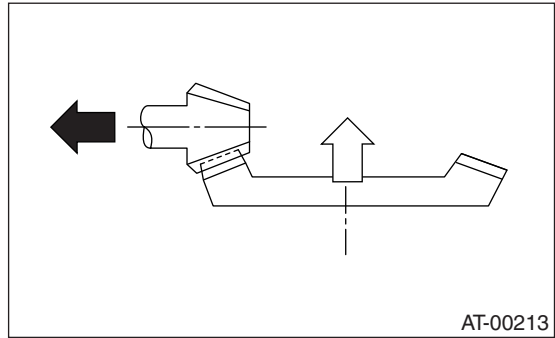

# FRONT DIFFERENTIAL ASSEMBLY

MANUAL TRANSMISSION AND DIFFERENTIAL

- Heel contact (Outside end contact)

**Checking item: Contact area is small.**

Contact pattern

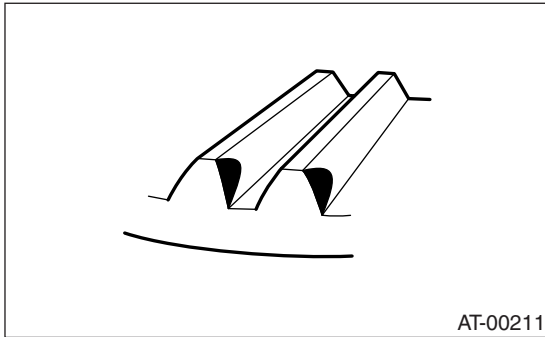

Corrective action: Reduce thickness of drive pinion shim in order to move drive pinion away from driven gear.

