

SHIFTER FORK AND ROD

MANUAL TRANSMISSION AND DIFFERENTIAL

21. Shifter Fork and Rod

A: REMOVAL

- 1) Remove the manual transmission assembly from vehicle. <Ref. to 5MT-27, REMOVAL, Manual Transmission Assembly.>
- 2) Remove the back-up light switch and neutral position switch. <Ref. to 5MT-37, REMOVAL, Switches and Harness.>
- 3) Remove the transfer case with extension case assembly. <Ref. to 5MT-41, REMOVAL, Transfer Case and Extension Case Assembly.>
- 4) Remove the transmission case. <Ref. to 5MT-53, REMOVAL, Transmission Case.>
- 5) Remove the drive pinion shaft assembly. <Ref. to 5MT-62, REMOVAL, Drive Pinion Shaft Assembly.>
- 6) Remove the main shaft assembly. <Ref. to 5MT-56, REMOVAL, Main Shaft Assembly.>
- 7) Remove the differential assembly. <Ref. to 5MT-70, REMOVAL, Front Differential Assembly.>
- 8) Drive out the straight pin with ST, and 5th shifter fork.

ST 398791700 STRAIGHT PIN REMOVER

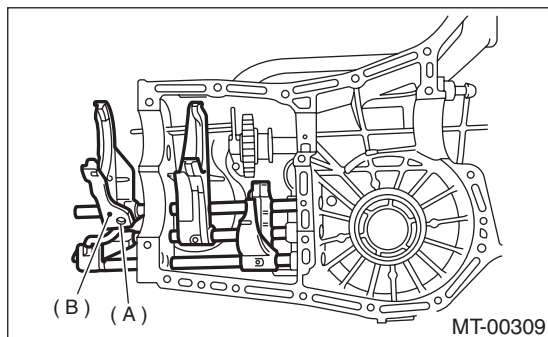

- (A) Straight pin
(B) 5th shifter fork

- 9) Remove the plugs, springs and checking balls.
- 10) Drive out the straight pin, and pull out 3-4 fork rod and shifter fork.

NOTE:

When removing the rod, keep other rods in neutral. Also, when pulling out the straight pin, remove it to-

ward the inside of case so that it does not hit against the case.

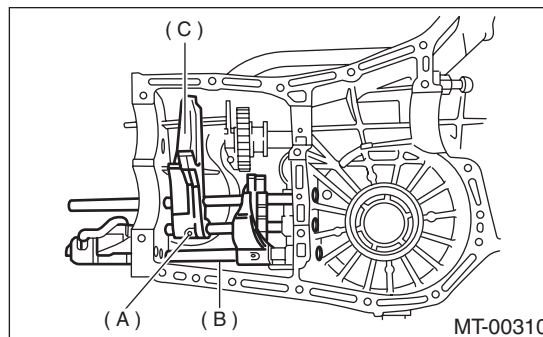

- (A) Straight pin
(B) 3-4 fork rod
(C) Shifter fork

- 11) Drive out the straight pin, and pull out 1-2 fork rod and shifter fork.
- 12) Remove the outer snap ring, and pull out the reverse shifter rod arm from reverse fork rod. Then take out the ball, spring and interlock plunger from rod.

And then remove the rod.

NOTE:

When pulling out the reverse shifter rod arm, be careful not to let the ball pop out of arm.

- 13) Remove the reverse shifter lever.

B: INSTALLATION

- 1) Install the reverse arm fork spring, ball and interlock plunger to reverse fork rod arm. Insert the reverse fork rod into hole in reverse fork rod arm, and hold it with outer snap ring using ST.

NOTE:

Apply grease to plunger to prevent it from falling.

ST 399411700 ACCENT BALL INSTALLER

- 2) Position the ball, spring and new gasket in reverse shifter rod hole, on left side transmission case, and tighten the checking ball plug.
- 3) Install the 1-2 fork rod into 1-2 shifter fork via the hole on the rear of transmission case.
- 4) Align the holes in rod and fork, and new drive straight pin into these holes using ST.

NOTE:

- Set other rods to neutral.
- Make sure the interlock plunger is on the 3-4 fork rod side.

ST 398791700 STRAIGHT PIN REMOVER

- 5) Install the interlock plunger onto 3-4 fork rod.

NOTE:

Apply a coat of grease to plunger to prevent it from falling.

SHIFTER FORK AND ROD

MANUAL TRANSMISSION AND DIFFERENTIAL

6) Install the 3-4 fork rod into 3-4 shifter fork via the hole on the rear of transmission case.

7) Align the holes in rod and fork, and new drive straight pin into these holes.

NOTE:

- Set the reverse fork rod to neutral.
- Make sure the interlock plunger (installing before) is on the reverse fork rod side.

ST 398791700 STRAIGHT PIN REMOVER

8) Install the 5th shifter fork onto the rear of reverse fork rod. Align holes in the two parts and new drive straight pin into place.

ST 398791700 STRAIGHT PIN REMOVER

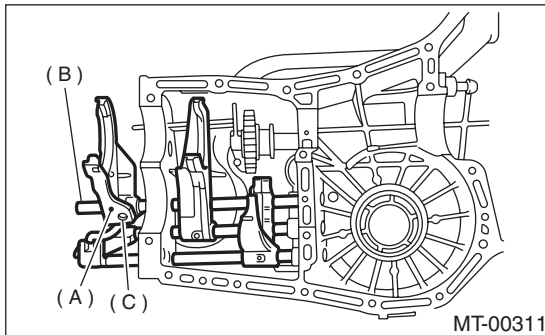

- (A) 5th shifter fork
- (B) Reverse fork rod
- (C) Straight pin

9) Position the balls, checking ball springs and new gaskets into 3-4 and 1-2 rod holes, and install plugs.

Tightening torque:

20 N·m (2.0 kgf·m, 14.1 ft·lb)

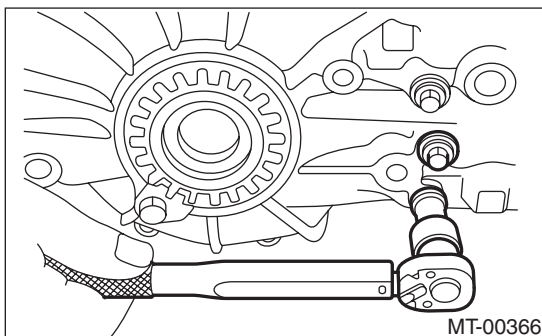

10) Install the differential assembly. <Ref. to 5MT-70, INSTALLATION, Front Differential Assembly.>

11) Install the main shaft assembly.

<Ref. to 5MT-56, INSTALLATION, Main Shaft Assembly.>

12) Install the drive pinion shaft assembly. <Ref. to 5MT-62, INSTALLATION, Drive Pinion Shaft Assembly.>

13) Install the transmission case. <Ref. to 5MT-54, INSTALLATION, Transmission Case.>

14) Install the transfer case with extension case assembly. <Ref. to 5MT-41, INSTALLATION, Transfer Case and Extension Case Assembly.>

15) Install the back-up light switch and neutral position switch. <Ref. to 5MT-37, INSTALLATION, Switches and Harness.>

16) Install the manual transmission assembly to vehicle. <Ref. to 5MT-30, INSTALLATION, Manual Transmission Assembly.>

C: INSPECTION

1) Check the shift shaft and shift rod for damage. Replace if damaged.

2) Gearshift mechanism:

Repair or replace the gearshift mechanism if excessively worn, bent, or defective in any way.

3) Inspect the clearance between 1st, 2nd driven gear and reverse driven gear. If any clearance is not within specifications, replace the shifter fork as required.

Clearance (a) and (b):
9.5 mm (0.374 in)

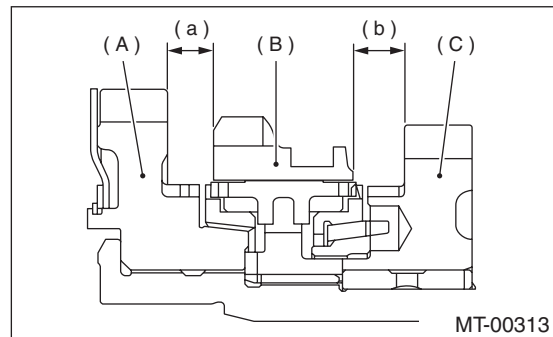

- (A) 1st driven gear
- (B) Reverse driven gear
- (C) 2nd driven gear

| 1st-2nd shifter fork | | |
|----------------------|------|--|
| Part No. | Mark | Remarks |
| 32804AA060 | 1 | Approach to 1st gear by 0.2 mm (0.008 in). |
| 32804AA070 | — | Standard |
| 32804AA080 | 3 | Become distant from 2nd gear by 0.2 mm (0.008 in). |

SHIFTER FORK AND ROD

MANUAL TRANSMISSION AND DIFFERENTIAL

4) Inspect the clearance between 3rd, 4th drive gear and coupling sleeve. If any clearance is not within specifications, replace the shifter fork as required.

Clearance (a) and (b):
9.3 mm (0.366 in)

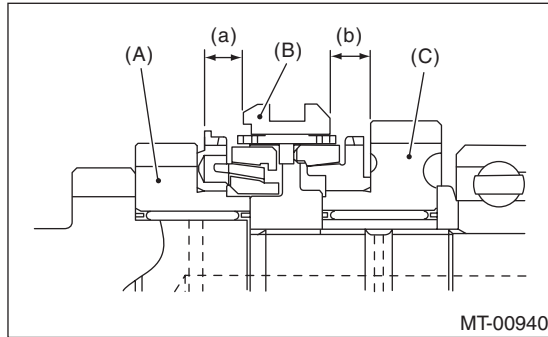

- (A) 3rd drive gear
- (B) Coupling sleeve
- (C) 4th drive gear

| 3rd-4th shifter fork | | |
|----------------------|------|--|
| Part No. | Mark | Remarks |
| 32810AA061 | 1 | Approach to 4th gear by 0.2 mm (0.008 in). |
| 32810AA071 | — | Standard |
| 32810AA101 | 3 | Become distant from 3rd gear by 0.2 mm (0.008 in). |

5) Inspect the clearance between 5th drive gear and coupling sleeve. If any clearance is not within specifications, replace the shifter fork as required.

Clearance (a):
9.3 mm (0.366 in)

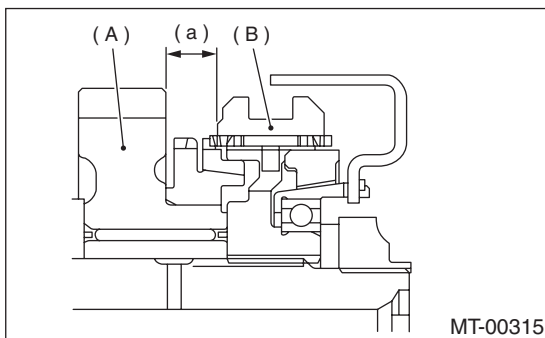

- (A) 5th drive gear
- (B) Coupling sleeve

| 5th shifter fork (Non-TURBO) | | |
|------------------------------|------|--|
| Part No. | Mark | Remarks |
| 32812AA201 | 7 | Approach to 5th gear by 0.2 mm (0.008 in). |
| 32812AA211 | — | Standard |
| 32812AA221 | 9 | Become distant from 5th gear by 0.2 mm (0.008 in). |

| 5th shifter fork (Turbo) | | |
|--------------------------|------|--|
| Part No. | Mark | Remarks |
| 32812AA231 | 7 | Approach to 5th gear by 0.2 mm (0.008 in). |
| 32812AA241 | — | Standard |
| 32812AA251 | 9 | Become distant from 5th gear by 0.2 mm (0.008 in). |

6) Inspect the rod end clearances (A) and (B). If any clearance is not within specifications, replace the rod or fork as required.

Clearance (A):

1st-2nd to 3rd-4th:

0.4 — 1.4 mm (0.016 — 0.055 in)

Clearance (B):

3rd-4th to 5th:

0.5 — 1.3 mm (0.020 — 0.051 in)

