

PROPORTIONING VALVE

BRAKE

10. Proportioning Valve

A: REMOVAL

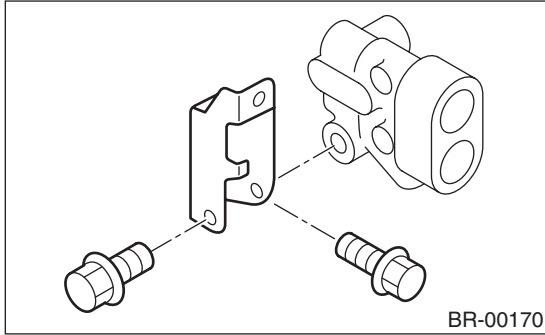

- 1) Pull up parking brake lever, and block the tires.
- 2) Remove brake pipe from proportioning valve at four places.
- 3) Remove proportioning valve from its bracket.

CAUTION:

Do not disassemble or adjust the proportioning valve. (The proportioning valve must be replaced as an assembly.)

B: INSTALLATION

- 1) Install proportioning valve to bracket.
- 2) Connect brake pipes correctly to proportioning valve.
- 3) Bleed air, then check each joint of brake pipe for oil leaks.

Tightening torque:

Proportioning valve to brake pipe flare nut:

15 N·m (1.5 kgf·m, 10.8 ft·lb)

Proportioning valve to bracket:

18 N·m (1.8 kgf·m, 13.0 ft·lb)

C: INSPECTION

- 1) Install oil pressure gauges to measure the master cylinder fluid pressure (front wheel brake fluid pressure) and rear wheel cylinder fluid pressure.
- 2) Bleed air from oil pressure gauges.
- 3) Check the master cylinder fluid pressure and rear wheel cylinder fluid pressure.

The standard values are shown in Figure.

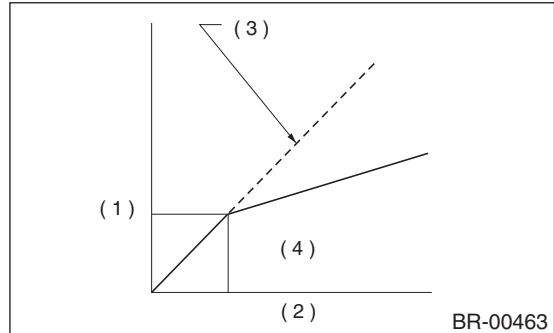

- (1) Rear wheel cylinder fluid pressure: P3
- (2) Master cylinder fluid pressure: P2
- (3) In case of failure in one circuit
- (4) When both circuits are normal

4) For the oil pressure in case of split point, refer to "SPECIFICATIONS".

<Ref. to BR-2, SPECIFICATIONS, General Description.>