

12. Air Bleeding

A: PROCEDURE

CAUTION:

- The FMVSS No. 116, fresh DOT3 or 4 brake fluid must be used.
- Cover bleeder with waste cloth when loosening it to prevent brake fluid from being splashed over surrounding parts.
- Avoid mixing different brands of brake fluid to prevent degrading the quality of the fluid.
- Be careful not to allow dirt or dust to get into the reservoir tank.
- Be extremely careful not to spill brake fluid. Brake fluid spilt on the vehicle body will harm the painted surface; wash it off quickly if spilt.

NOTE:

- Start with the brakes (wheels) connected to the secondary chamber of the master cylinder.
- The time interval between two brake pedal operations (from the time when the pedal is released to the time when it is depressed another time) should be approximately 3 seconds.
- The air bleeder on each brake should be released for 1 to 2 seconds.

1. MASTER CYLINDER

NOTE:

- If master cylinder is disassembled or reservoir tank is empty, bleed master cylinder.
 - During bleeding operation, keep the brake reservoir tank filled with brake fluid to eliminate entry of air.
 - Brake pedal operation must be very slow.
 - For convenience and safety, two people should do the work.
- 1) Loosen wheel nuts, jack-up vehicle, support it with safety stands, and remove wheel.
 - 2) Disconnect brake line at primary and secondary sides.
 - 3) Put plastic bag cover on the master cylinder.
 - 4) Carefully depress and hold brake pedal.

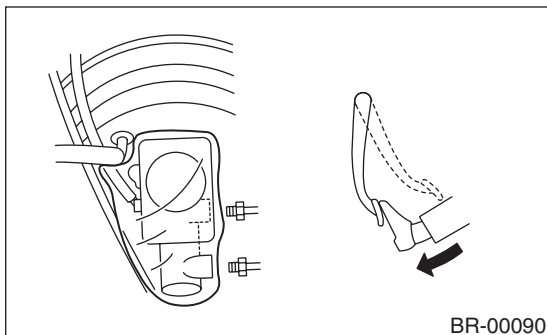

- 5) Close outlet plug with your finger, and release brake pedal.

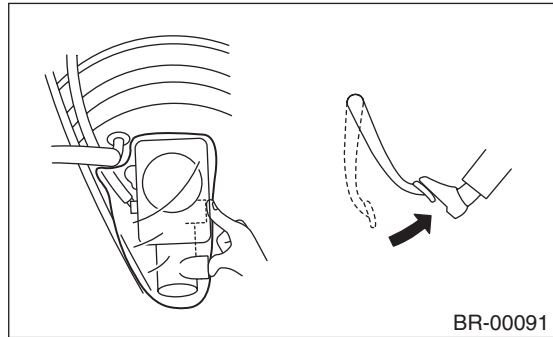

- 6) Repeat above steps 4) and 5) until master cylinder is completely bled.
- 7) Install brake pipes to master cylinder.

Tightening torque:

8 N-m (0.8 kgf-m, 5.8 ft-lb)

- 8) Cleanly wash away brake fluid spilt on master cylinder etc.
- 9) Bleed air from brake system. <Ref. to BR-33, BRAKE LINE, PROCEDURE, Air Bleeding.>

2. BRAKE LINE

NOTE:

- During bleeding operation, keep the brake reservoir tank filled with brake fluid to eliminate entry of air.
 - Brake pedal operation must be very slow.
 - For convenience and safety, two people should do the work.
- 1) Make sure that there is no leak from joints and connections of the brake system.
 - 2) Fit one end of vinyl tube into the air bleeder and put the other end into a brake fluid container.

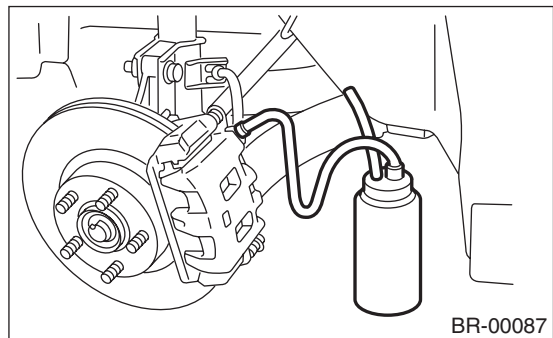

AIR BLEEDING

BRAKE

CAUTION:

Brake fluid replacement sequence; (A) Front right → (B) Rear left → (C) Front left → (D) Rear right

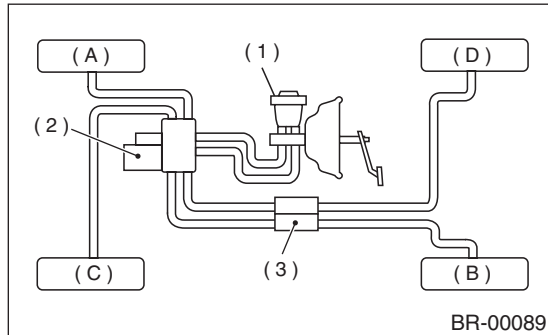

- (1) Master cylinder
- (2) Hydraulic unit
- (3) Proportioning valve

3) Slowly depress the brake pedal and keep it depressed. Then, open the air bleeder to discharge air together with the fluid.

Release air bleeder for 1 to 2 seconds.

Next, with the bleeder closed, slowly release the brake pedal.

Repeat these steps until there are no more air bubbles in the vinyl tube.

Allow 3 to 4 seconds between two brake pedal operations.

CAUTION:

Cover bleeder with waste cloth, when loosening it, to prevent brake fluid from being splashed over surrounding parts.

NOTE:

Brake pedal operating must be very slow.

4) Tighten air bleeder securely when no air bubbles are visible.

Air bleeder tightening torque:

8 N·m (0.8 kgf·m, 5.8 ft·lb)

5) Perform these steps for the brakes connecting to the secondary chamber of master cylinder, first, and then for the ones connecting to primary chamber. With all procedures completed, fully depress the brake pedal and keep it in that position for approximately 20 seconds to make sure that there is no leak evident in the entire system.

6) Check the pedal stroke.

While the engine is idling, depress the brake pedal with a 490 N (50 kgf, 110 lb) load and measure the distance between the brake pedal and steering wheel. With the brake pedal released, measure the distance between the pedal and steering wheel again. The difference between the two measurements must be more than specified.

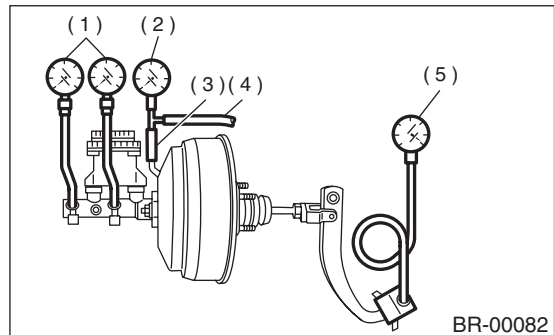

- (1) Pressure gauge
- (2) Vacuum gauge
- (3) Adapter hose
- (4) Vacuum hose
- (5) Pedal force gauge

Specified pedal stroke:

95 mm (3.74 in)

When depressing brake pedal with a 490 N (50 kgf, 110 lb) load.

7) If the distance is more than specifications, there is a possibility that air is in the brake line. Bleed brake line until pedal stroke meets the specification.

8) Operate hydraulic control unit in the sequence control mode.

With ABS: <Ref. to ABS-11, ABS Sequence Control.>

9) Recheck the brake stroke.

10) If the distance is more than specifications, there is a possibility air is in the inside of the hydraulic unit. Repeat above steps 2) to 9) above until pedal stroke meets the specification.

11) Add brake fluid to the required level (MAX. level) of reservoir tank.

12) As a final step, test run the vehicle at low speed and apply brakes relatively hard 2 to 3 times to ensure that brakes provide normal braking action on all four wheels without dragging and uneven braking.