

15. Brake Pedal

A: REMOVAL

1. MT MODEL

- 1) Pull up parking brake lever and block tires.
- 2) Disconnect ground cable from battery.
- 3) Remove steering column.
<Ref. to PS-20, REMOVAL, Tilt Steering Column.>
- 4) Disconnect connectors from stop light and clutch switches.
- 5) Remove snap pins which secure lever to push rod and operating rod.
- 6) Remove clevis pins which secure lever to push rod and operating rod.

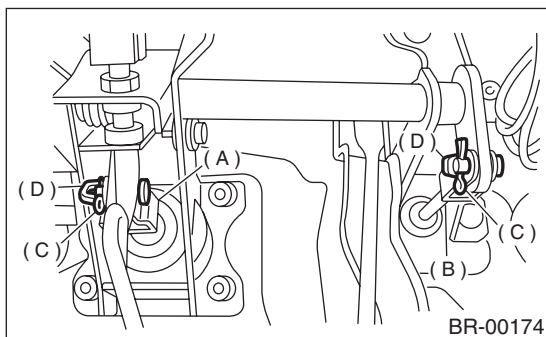

- (A) Operating rod
- (B) Push rod
- (C) Snap pin
- (D) Clevis pin

- 7) Remove nut which secures clutch master cylinder.

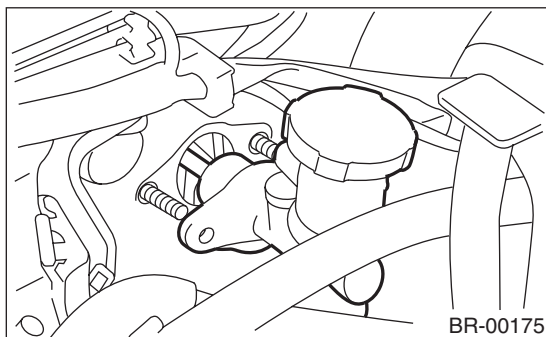

- 8) Remove bolts and nuts which secure brake and clutch pedals, and remove pedal assembly.

2. AT MODEL

- 1) Pull up parking brake lever.
- 2) Disconnect ground cable from battery.
- 3) Remove instrument panel lower cover from instrument panel.
- 4) Remove clevis pin which secures brake pedal to brake booster operating rod. Also disconnect stop light switch connector.

- 5) Remove AT unit from brake panel (2 nuts).
- 6) Remove two bolts and four nuts which secure brake pedal to pedal.

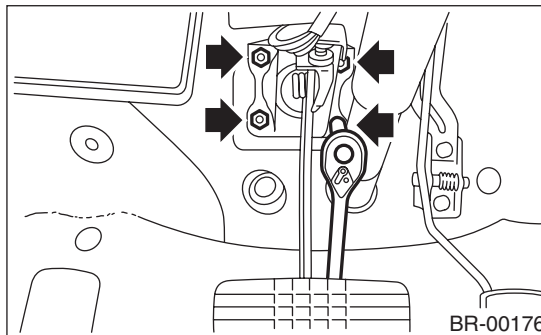

B: INSTALLATION

- 1) Install in the reverse order of removal.

CAUTION:

- If cable clamp is damaged, replace it with a new one.
- Never fail to cover outer cable end with boot.
- Be careful not to kink accelerator cable.
- Always use new clevis pins.

- 2) Adjustment of clutch pedal <Ref. to BR-39, ASSEMBLY, Brake Pedal.>
- 3) Inspect after pedal installation <Ref. to BR-40, INSPECTION, Brake Pedal.>

C: DISASSEMBLY

1. MT MODEL

- 1) Remove the brake switch.
<Ref. to BR-41, REMOVAL, Stop Light Switch.>
- 2) Remove the clutch pedal.
<Ref. to CL-27, DISASSEMBLY, Clutch Pedal.>
- 3) Remove the clutch master cylinder bracket.

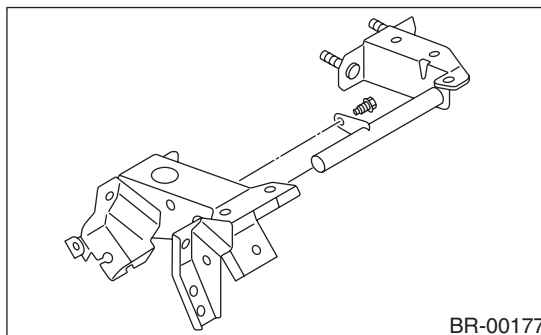

4) Remove bushing, spring and stopper.

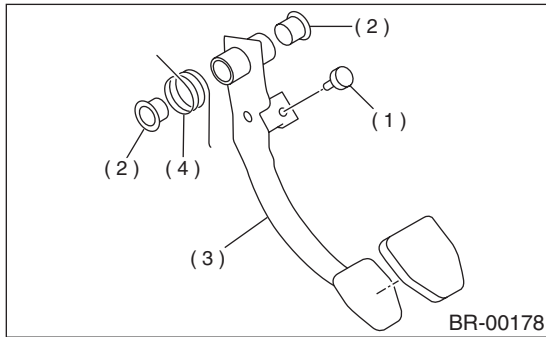

- (1) Stopper
- (2) Bushing
- (3) Brake pedal
- (4) Brake pedal spring

5) Remove the brake pedal pad.

2. AT MODEL

- 1) Remove the brake switch.
- 2) Unbolt, and then remove the brake pedal.

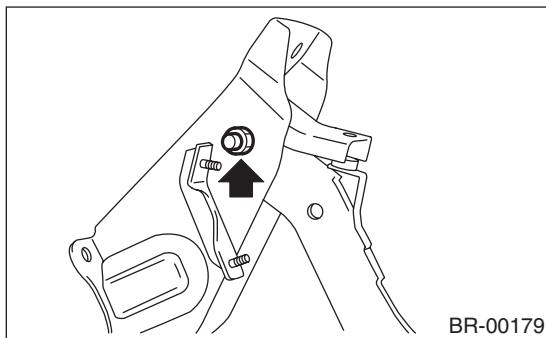

3) Remove bushing, spacer and spring.

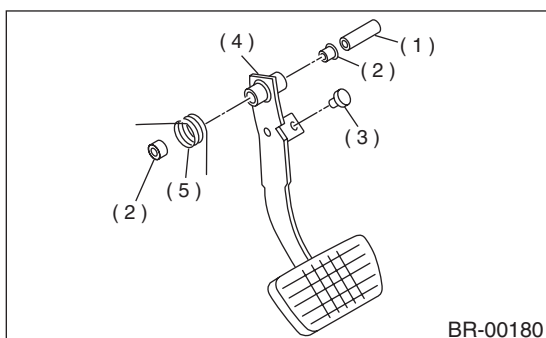

- (1) Spacer
- (2) Bushing
- (3) Stopper
- (4) Brake pedal
- (5) Brake pedal spring

4) Remove the brake pedal pad.

D: ASSEMBLY

- 1) Attach stop light switch, etc. to pedal bracket temporarily.
- 2) Clean inside of bores of clutch pedal and brake pedal, apply grease, and set bushings into bores.
- 3) Align bores of pedal bracket, clutch pedal and brake pedal, attach brake pedal return spring and clutch pedal effort reducing spring (vehicle with hill holder), and then install pedal bolt.

NOTE:

Clean up inside of bushings and apply grease before installing spacer.

Tightening torque:

T: 29 N·m (3.0 kgf-m, 21.7 ft-lb)

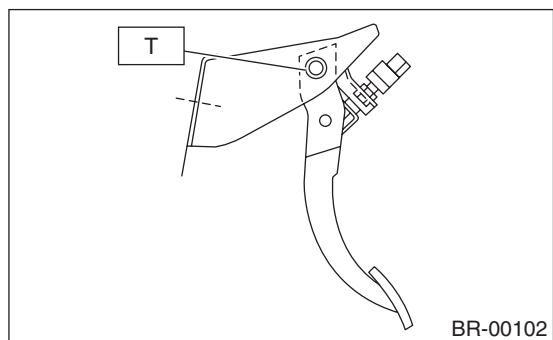

4) Set brake pedal position by adjusting position of stop light switch.

Pedal position: L

126.4 mm (4.98 in)

Tightening torque:

T: 8 N·m (0.8 kgf-m, 5.8 ft-lb)

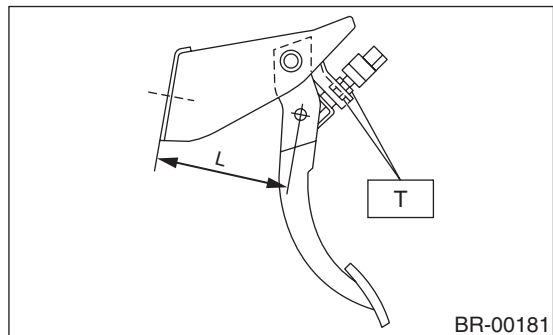

BRAKE PEDAL

BRAKE

E: INSPECTION

1) Move brake and clutch pedal pads in the lateral direction with a force of approximately 10 N (1 kgf, 2 lb) to ensure pedal deflection is in specified range.

CAUTION:

If excessive deflection is noted, replace bushings with new ones.

Deflection of brake and clutch pedal:

Service limit

5.0 mm (0.197 in) or less

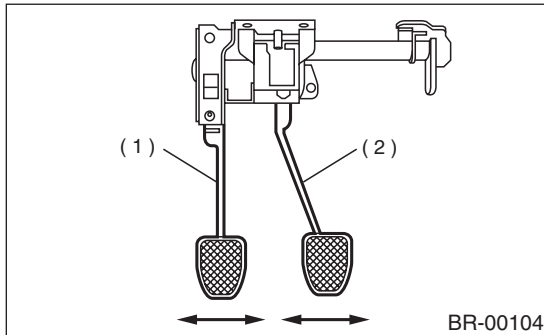

- (1) Clutch pedal
- (2) Brake pedal

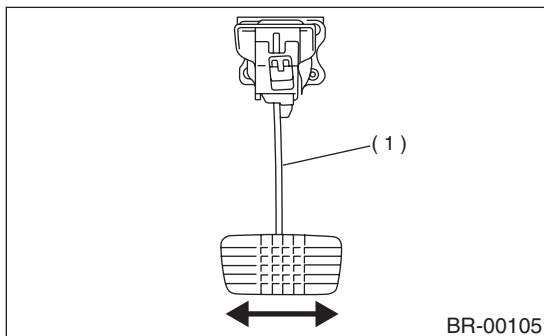

- (1) Brake pedal

2) Check position of pedal pad.

Pedal height: L

AT: 158 mm (6.22 in)

MT: 153 mm (6.02 in)

Brake pedal free play: A

1 — 3 mm (0.04 — 0.12 in) [Depress brake pedal pad with a force of less than 10 N (1 kgf, 2 lb).]

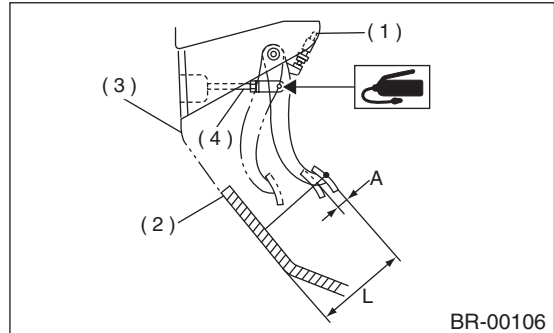

- (1) Stop light switch
- (2) Mat
- (3) Toe board
- (4) Brake booster operating rod

3) If it is not in specified value, adjust it by adjusting brake booster operating rod length.