

BRAKE BOOSTER

BRAKE

9. Brake Booster

A: REMOVAL

CAUTION:

If external force is applied from above when brake booster is placed in this position, the resin portion as indicated by "P", may be damaged.

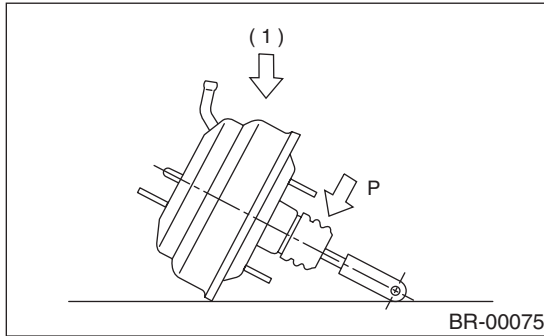

(1) Force

- 1) Pull up parking brake lever, and block tires.
- 2) Disconnect ground cable from battery.
- 3) Remove or disconnect the following parts at engine compartment.
 - (1) Disconnect connector for brake fluid level indicator.
 - (2) Remove brake pipes from master cylinder.
 - (3) Remove master cylinder installing nuts.
 - (4) Disconnect vacuum hose from brake booster.
- 4) Remove the following parts from the pedal bracket.
 - (1) Snap pin and clevis pin
 - (2) Four brake booster installing nuts
- 5) Remove brake booster while shunning brake pipes.

NOTE:

- Be careful not to drop brake booster. Brake booster should be discarded if it has been dropped.
- Use special care when handling operating rod. If excessive force is applied to operating rod, sufficient to cause a change in the angle in excess of $\pm 3^\circ$, it may result in damage to the power piston cylinder.
- Use care when placing brake booster on the floor.
- Do not change the push rod length. If it has been changed, reset the projected length "L" to the standard length.

Standard:

L = 10 mm (0.39 in)

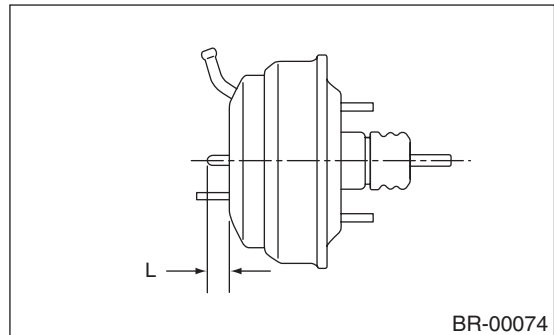

BR-00074

B: INSTALLATION

- 1) Mount brake booster in position.
- 2) Connect operating rod to brake pedal with clevis pin and snap pin.

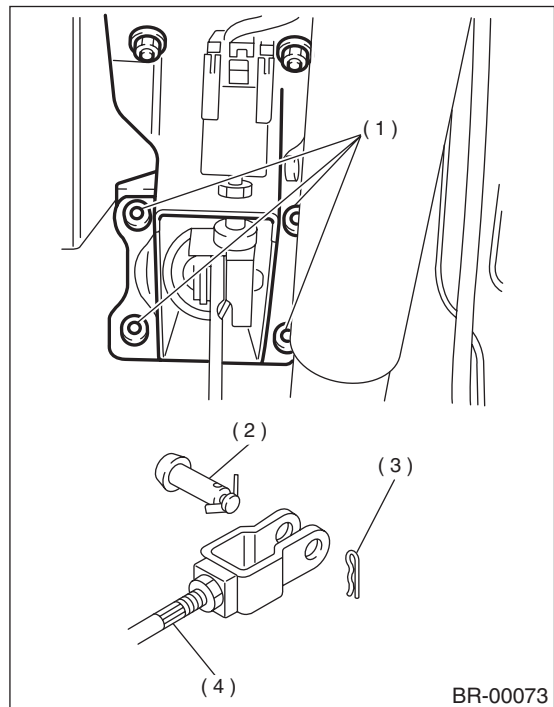

BR-00073

- (1) Nuts
- (2) Clevis pin
- (3) Snap pin
- (4) Operating rod

3) Connect vacuum hose to brake booster.

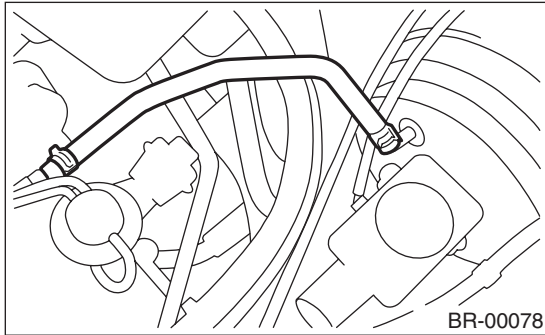

- 4) Mount master cylinder onto brake booster.
- 5) Connect brake pipes to master cylinder.
- 6) Connect electric connector for brake fluid level indicator.
- 7) Adjust operating rod of brake booster.

Standard: L
145.3 mm (5.72 in)

If it is not in specified value, adjust it by adjusting brake booster operating rod.

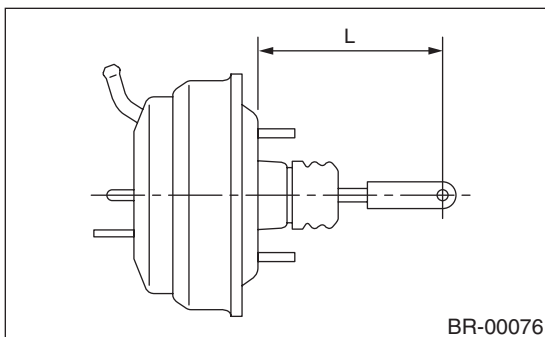

- 8) Measure the clearance between threaded end of stop light switch and stopper.
- If it is not in specified value, adjust it by adjusting position of stop light switch.

CAUTION:
Be careful not to rotate stop light switch.

Stop light switch clearance: A
0.3 mm (0.012 in)

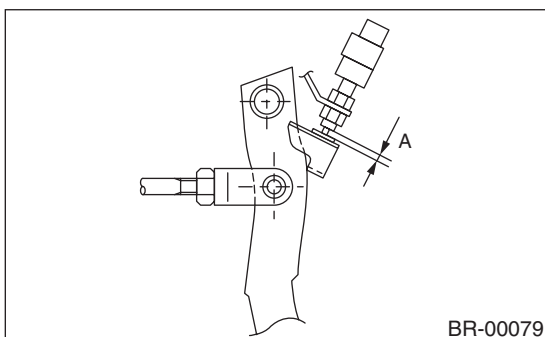

- 9) Apply grease to operating rod connecting pin to prevent it from wearing.

10) Bleed air from brake system.

Tightening torque (Air bleeder screw):
8 N·m (0.8 kgf·m, 5.8 ft·lb)

11) Conduct road tests to ensure brakes do not drag.

C: INSPECTION

1. OPERATION CHECK (WITHOUT GAUGES)

CAUTION:
When checking operation, be sure to securely apply the hand brake.

• Checking without gauges

This method cannot determine the exact portion which has failed, but it can provide a rough understanding of the nature of the failure if checking is conducted in accordance with the following procedures.

• Air tightness check

Start engine, and run it for 1 to 2 minutes, then turn it off. Depress brake pedal several times applying the same pedal force as that used in ordinary braking operations. The pedal stroke should be greatest on the 1st depression, and it should become smaller with each successive depression. If no change occurs in the pedal height while in a depressed state, brake booster is faulty.

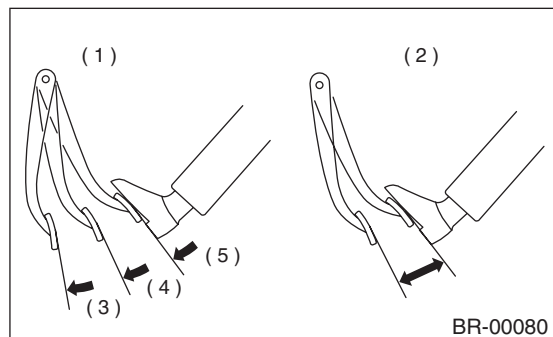

- (1) OK
- (2) NOT OK
- (3) 1st
- (4) 2nd
- (5) 3rd

NOTE:

- In the event of defective operation, inspect the condition of the check valve and vacuum hose.
- Replace them if faulty and conduct the test again.
- If no improvement is observed, check precisely with gauges.

BRAKE BOOSTER

BRAKE

• Operation check

1) With engine off, depress brake pedal several times applying the same pedal force and make sure that the pedal height does not vary with each depression of the pedal.

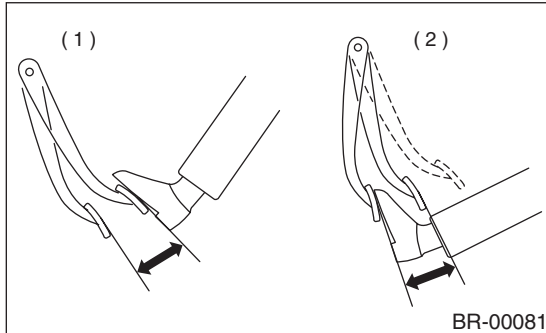

- (1) When engine is stopped
- (2) When engine is started

2) With brake pedal depressed, start engine.
3) As engine starts, brake pedal should move slightly toward the floor. If no change occurs in the pedal height, brake booster is faulty.

NOTE:

If faulty, check precisely with gauges.

• Loaded air tightness check

Depress brake pedal while engine is running, and turn off engine while the pedal is still depressed. Keep the pedal depressed for 30 seconds; if no change occurs in the pedal height, brake booster is functioning normally; if the pedal height increases, it is faulty.

NOTE:

If faulty, check precisely with gauges.

2. OPERATION CHECK (WITH GAUGES)

CAUTION:

When checking operation, be sure to securely apply the hand brake.

• Checking with gauges

Connect gauges as shown in Figure. After bleeding air from pressure gauges, proceed to each check.

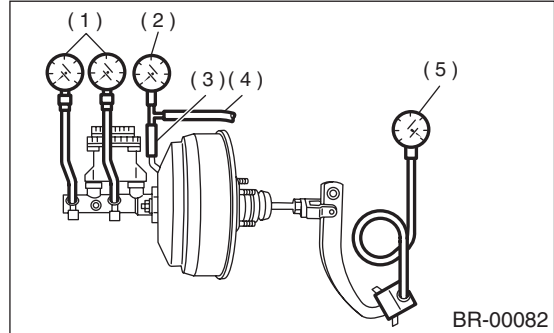

- (1) Pressure gauge
- (2) Vacuum gauge
- (3) Adapter hose
- (4) Vacuum hose
- (5) Pedal force gauge

• Air tightness check

1) Start engine and keep it running until a vacuum of 66.7 kPa (500 mmHg, 19.69 inHg) = point A is indicated on vacuum gauge. Do not depress brake pedal.

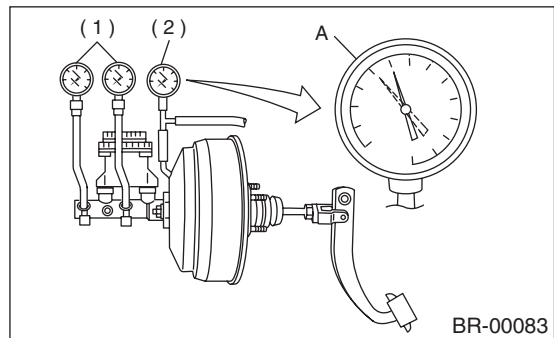

- (1) Pressure gauge
- (2) Vacuum gauge

2) Stop engine and watch the gauge. If the vacuum drop range is less than 3.3 kPa (25 mmHg, 0.98 inHg) within 15 seconds after stopping engine, brake booster is functioning properly.

If defective, the cause may be one of those listed below.

- Check valve malfunction
- Leak from vacuum hose
- Leak from the shell jointed portion or stud bolt welded portion

- Damaged diaphragm
- Leak from valve body seal and bearing portion
- Leak from plate and seal assembly portion
- Leak from poppet valve assembly portion
- **Loaded air tightness check**

1) Start engine and depress brake pedal with pedal force of 196 N (20 kgf, 44 lb). Keep engine running until a vacuum of 66.7 kPa (500 mmHg, 19.69 inHg) = point B is indicated on vacuum gauge while the pedal is still depressed.

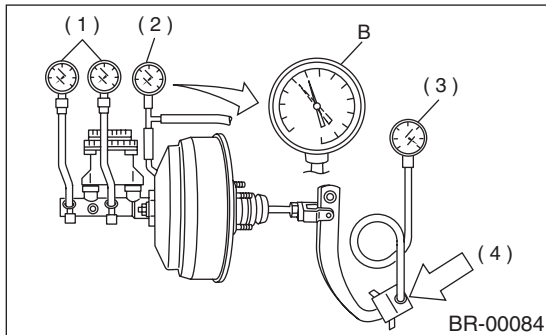

- (1) Pressure gauge
- (2) Vacuum gauge
- (3) Pedal force gauge
- (4) Depress

2) Stop engine and watch vacuum gauge. If the vacuum drop range is less than 3.3 kPa (25 mmHg, 0.98 inHg) within 15 seconds after stopping engine, brake booster is functioning properly. If defective, refer to "AIR TIGHTNESS CHECK".
 <Ref. to BR-27, INSPECTION, Brake Booster.>

• **Lack of boosting action check**

Turn off engine, and set the vacuum gauge reading at "0". Then, check the fluid pressure when brake pedal is depressed. The pressure must be greater than the standard value listed.

Brake pedal force	147 N (15 kgf, 33 lb)	294 N (30 kgf, 66 lb)
Fluid pressure	588 kPa (6 kg/cm ² , 85 psi)	1,569 kPa (16 kg/cm ² , 228 psi)

• **Boosting action check**

Set the vacuum gauge reading at 66.7 kPa (500 mmHg, 19.69 inHg) by running engine. Then, check the fluid pressure when brake pedal is depressed. The pressure must be greater than the standard value listed.

Brake pedal force	147 N (15 kgf, 33 lb)	294 N (30 kgf, 66 lb)
Fluid pressure	6,178 kPa (63 kg/cm ² , 896 psi)	9,709 kPa (99 /cm ² , 1,408 psi)