

4. Rear Differential for T-type

A: REMOVAL

- 1) Disconnect ground cable from battery.
- 2) Move select lever or gear shift lever to "N".
- 3) Loosen wheel nuts.
- 4) Release the parking brake.
- 5) Jack-up vehicle and support it with sturdy racks.
- 6) Remove wheels.
- 7) Remove rear exhaust pipe and muffler.
- 8) Remove heat shield cover.

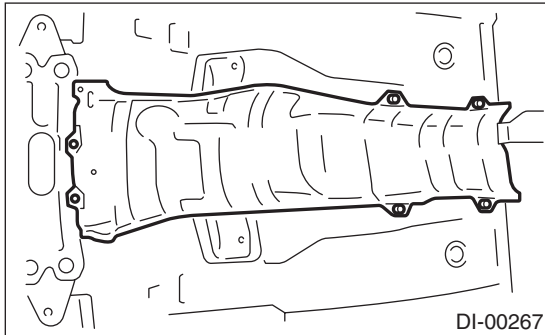

- 9) Remove propeller shaft.
<Ref. to DS-15, REMOVAL, Propeller Shaft.>
- 10) Remove rear differential protector (if equipped).
- 11) Prepare a transmission jack and a band.

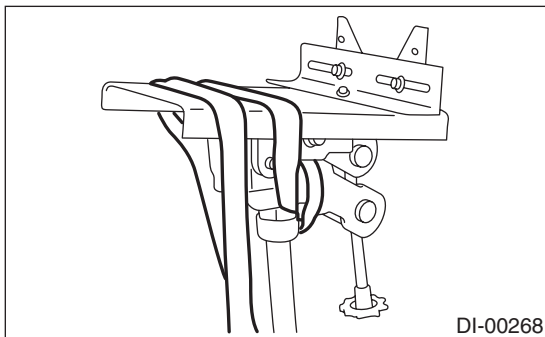

- 12) Loosen self-locking nuts connecting rear differential to rear crossmember.

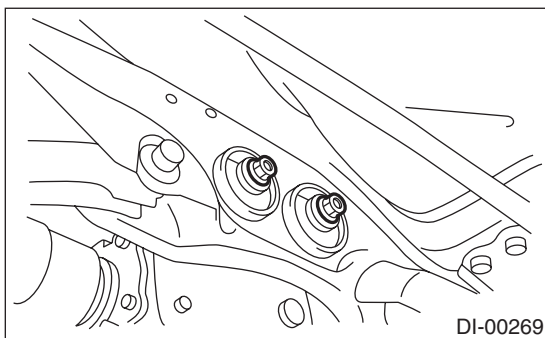

- 13) Remove DOJ of rear drive shaft from rear differential using ST.

ST 28099PA100 DRIVE SHAFT REMOVER

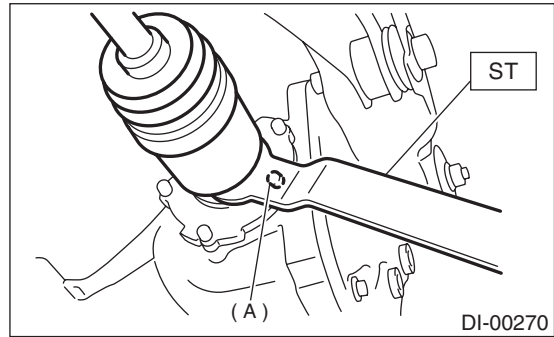

(A) Bolt

- 14) Remove protector nuts.

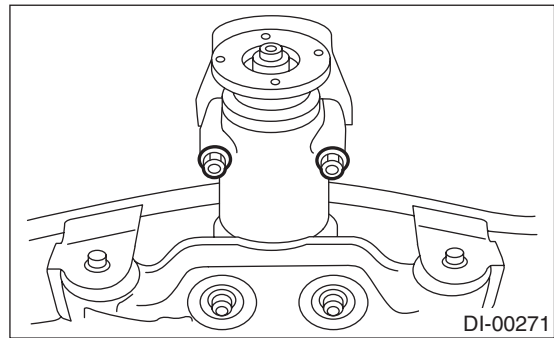

- 15) Remove rear differential front member.

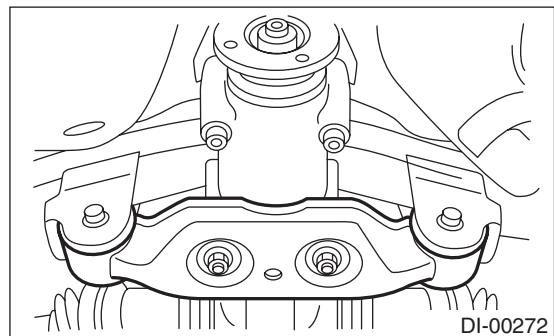

- 16) Support rear differential with transmission jack.

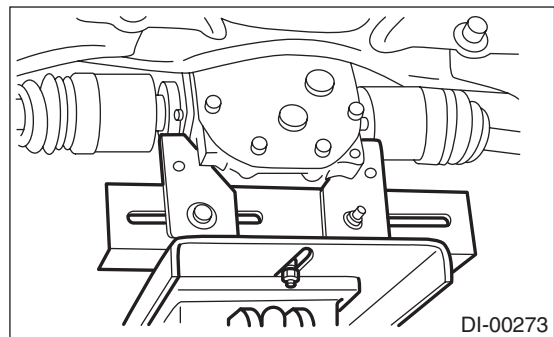

REAR DIFFERENTIAL FOR T-TYPE

DIFFERENTIALS

- 17) Be sure to secure differential to transmission jack by hand.
- 18) Remove self-locking nuts connecting rear differential to crossmember.
- 19) Remove rear differential stud bolt from rear crossmember bushing.

NOTE:

Carefully adjust angle and position of transmission jack and jack stand as required during stud bolt removal.

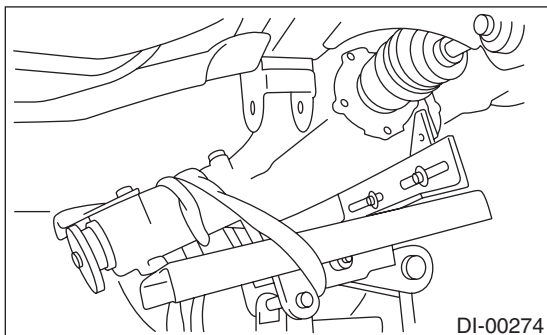

- 20) After removing rear differential stud bolt from rear crossmember, lower transmission jack stand. Do not allow rear drive shaft to strike lateral link bolt.

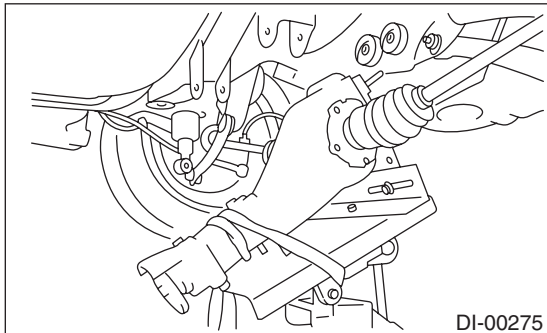

- 21) Pull out axle shaft from rear differential.

NOTE:

If axle shaft is difficult to remove from rear differential, use ST to remove it.

ST 28099PA100 DRIVE SHAFT REMOVER

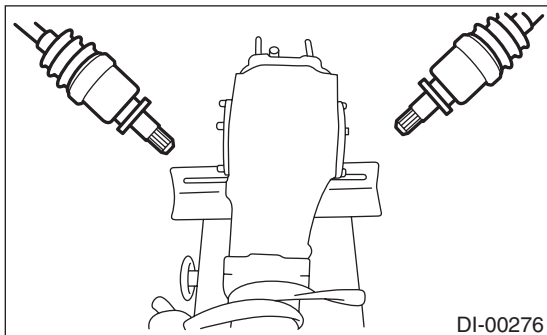

- 22) Take down transmission jack.
- 23) Secure rear drive shaft to lateral link use wire.

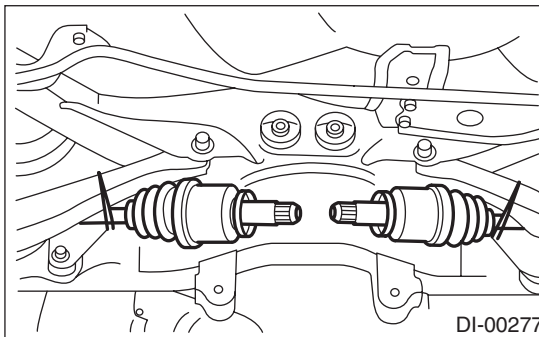

- 24) Remove protector and rear differential member plate from rear differential.

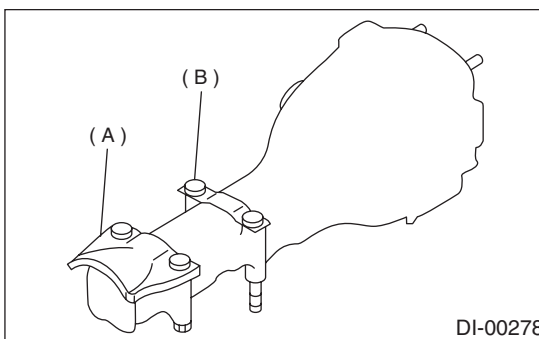

- (A) Protector
- (B) Rear differential member plate

B: INSTALLATION

- 1) Install protector and rear differential member plate to rear differential.

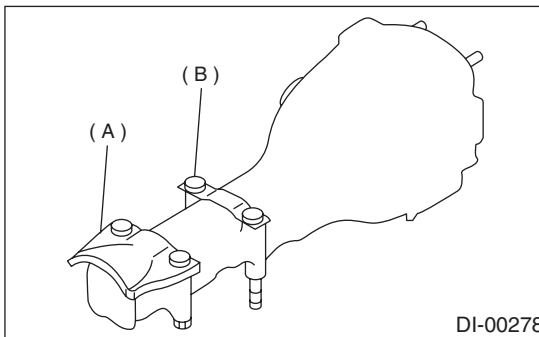

- (A) Protector
- (B) Rear differential member plate

- 2) Set rear differential to transmission jack.

NOTE:

Secure rear differential to transmission jack using a band.

- 3) Install ST to rear differential.
ST 28099PA090 OIL SEAL PROTECTOR

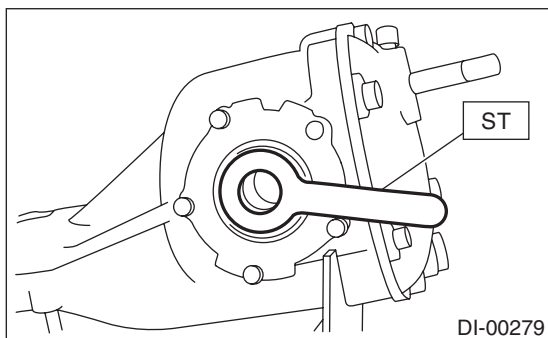

- 4) Insert the spline shaft until the spline portion is inside the side oil seal.

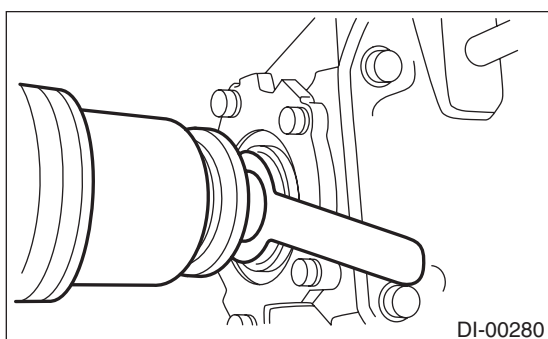

- 5) Remove ST from rear differential.
ST 28099PA090 OIL SEAL PROTECTOR
6) Completely insert axle shaft into rear differential by pressing rear differential.

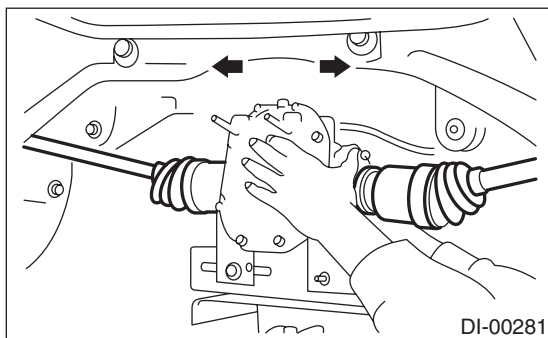

- 7) Adjust transmission jack as required so rear differential stud bolt is properly inserted into rear crossmember bushing.

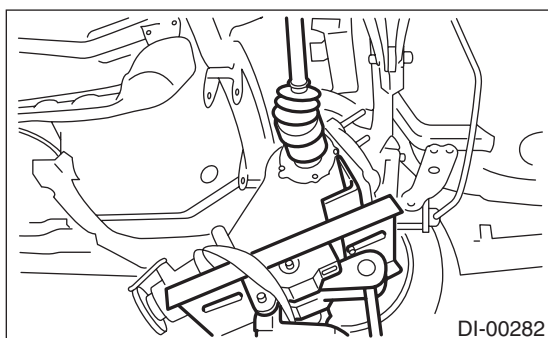

- 8) After rear differential stud bolt has been inserted into rear crossmember bushing, raise transmission jack to make jack rear differential level.

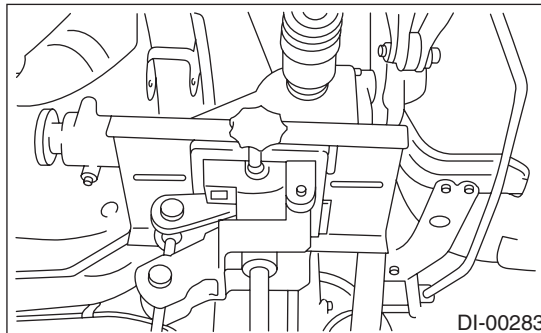

- 9) Temporarily tighten rear crossmember self-locking nuts.

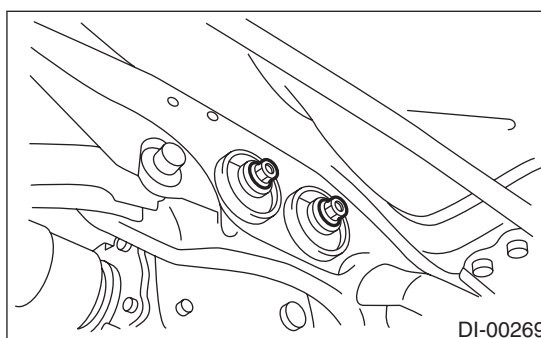

- 10) Remove band from rear differential. Raise rear differential just enough to move transmission jack away from it.

- 11) Install rear differential front member.

Tightening torque:

T1: 65 N·m (6.6 kgf-m, 48 ft-lb)

T2: 110 N·m (11.2 kgf-m, 81 ft-lb)

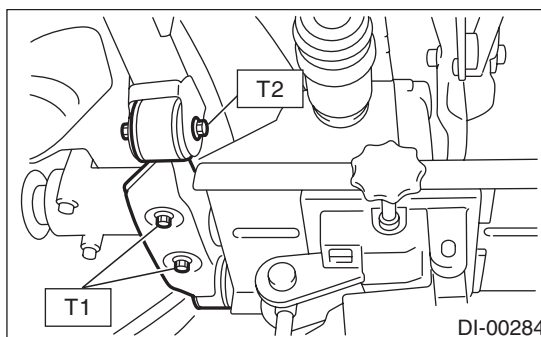

REAR DIFFERENTIAL FOR T-TYPE

DIFFERENTIALS

12) Tighten self-locking nuts.

Tightening torque:

70 N·m (7.1 kgf·m, 51 ft·lb)

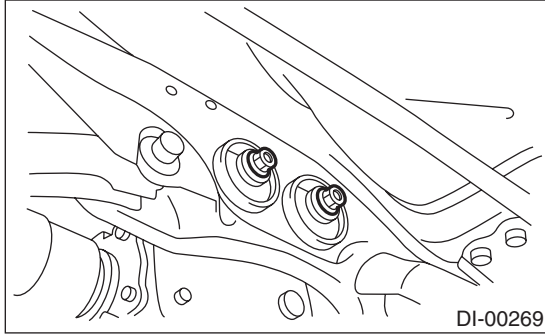

13) Tighten protector nut.

Tightening torque:

65 N·m (6.6 kgf·m, 48.0 ft·lb)

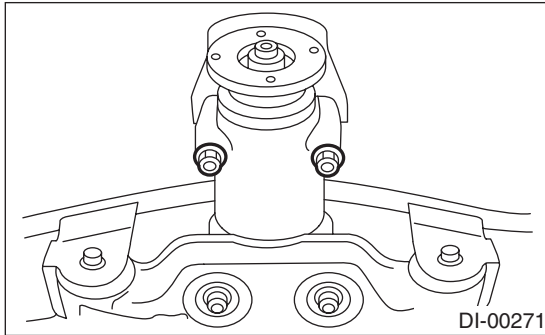

14) Take down transmission jack.

15) Install propeller shaft.

<Ref. to DS-16, INSTALLATION, Propeller Shaft.>

16) Install heat shield cover.

17) Install rear exhaust pipe and muffler.

18) After installing rear differential carrier on vehicle, remove filler plug and replenish gear oil up to upper level mark.

Oil capacity:

0.8 ℓ (0.8 US qt, 0.7 Imp qt)

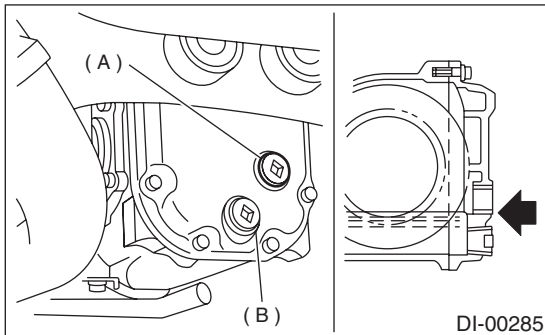

- (A) Filler plug
- (B) Drain plug

19) Tighten filler plug.

NOTE:

Apply fluid gasket to plug.

Fluid gasket:

THREE BOND 1105 (Part No. 04403010) or equivalent

Tightening torque:

49.0 N·m (5.0 kgf·m, 36.2 ft·lb)

C: DISASSEMBLY

To detect real cause of trouble, inspect the following items before disassembling.

- Tooth contact of crown gear and pinion, and backlash
- Runout of crown gear at its back surface
- Turning resistance of drive pinion

1) Set ST on vise and install the differential assembly to ST.

ST 398217700 ATTACHMENT

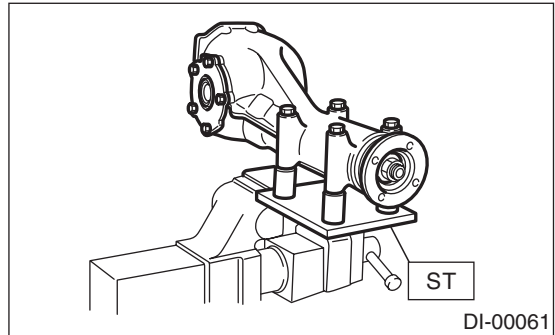

2) Drain gear oil by removing plug.

3) Remove the air breather cap.

NOTE:

- Do not attempt to remove the air breather cap unless necessary.
- When the air breather cap is removed, replace it with a new one.

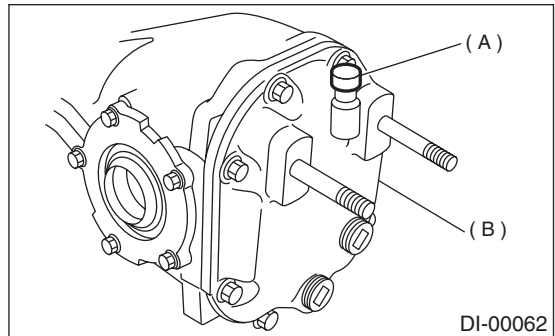

- (A) Air breather cap
- (B) Rear cover

4) Remove rear cover by loosening bolts.

NOTE:

Remove rear cover while tapping it lightly with plastic hammer, if it is hard to remove.

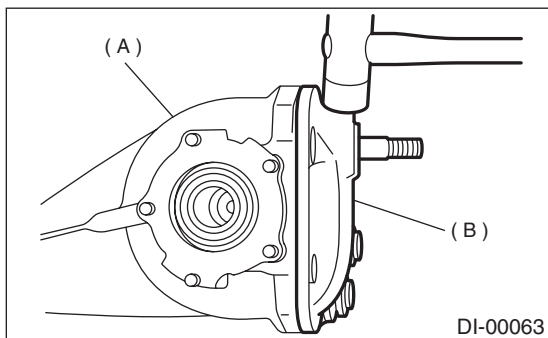

(A) Rear cover
(B) Differential carrier

5) Make right and left side bearing retainers in order to identify them at reassembly. Remove side bearing retainer attaching bolts, set ST to differential case, and extract right and left side bearing retainers with a puller.

NOTE:

Each shim, which is installed to adjust the side bearing preload, should be kept together with its mating retainer.

ST 398457700 ATTACHMENT

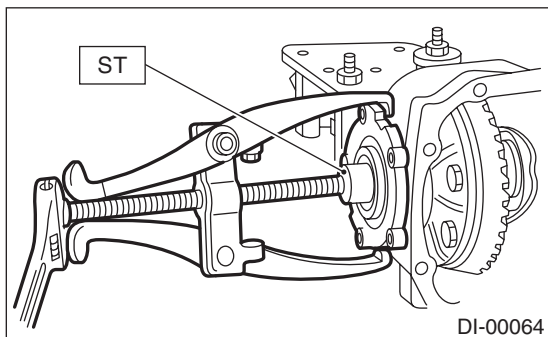

6) Pull out differential case assembly from differential carrier.

CAUTION:

Be careful not to hit the teeth against the case.

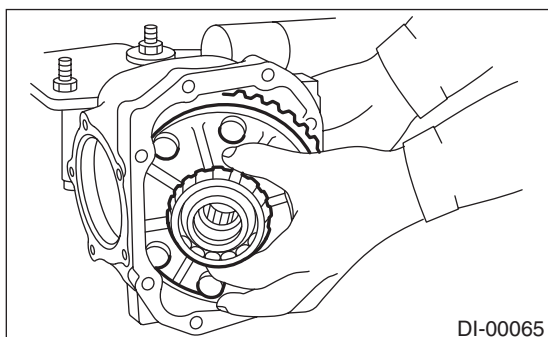

7) Remove O-ring from side bearing retainer.

8) Remove oil seal from side bearing retainer.

9) Remove bearing cup from side bearing retainer using ST.

ST 398527700 PULLER ASSY

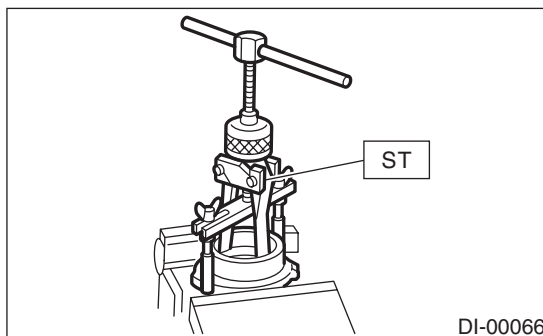

10) Extract bearing cone with ST.

NOTE:

- Do not attempt to disassemble the parts unless necessary.

- Set puller so that its claws catch the edge of the bearing cone.

- Never mix up the right and left hand bearing races and cones.

ST 399527700 PULLER SET

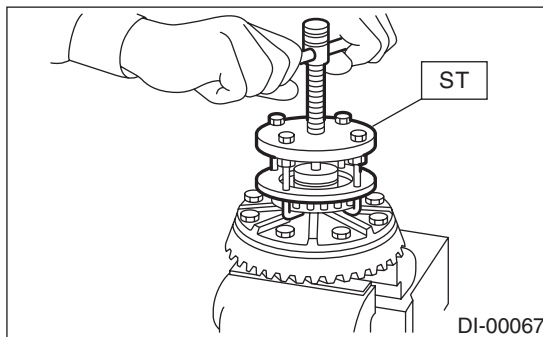

11) Remove crown gear by loosening crown gear bolts.

NOTE:

Further disassembling is not allowed.

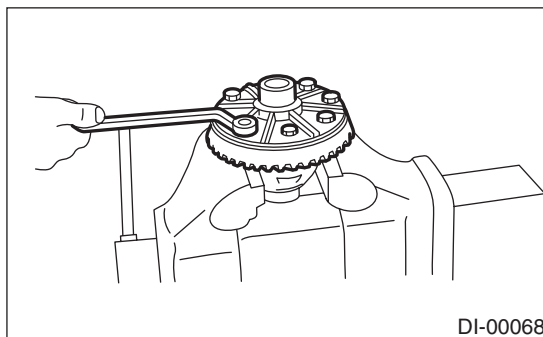

REAR DIFFERENTIAL FOR T-TYPE

DIFFERENTIALS

12) Hold companion flange with ST and remove drive pinion nut.

ST 498427200 FLANGE WRENCH

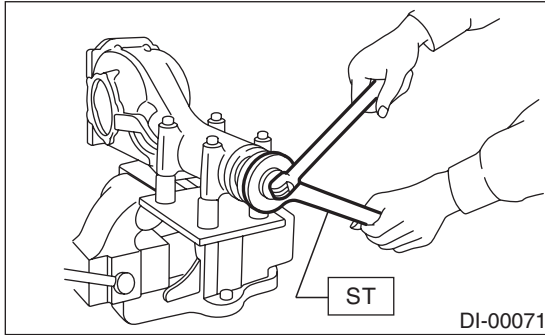

13) Extract the companion flange with a puller.

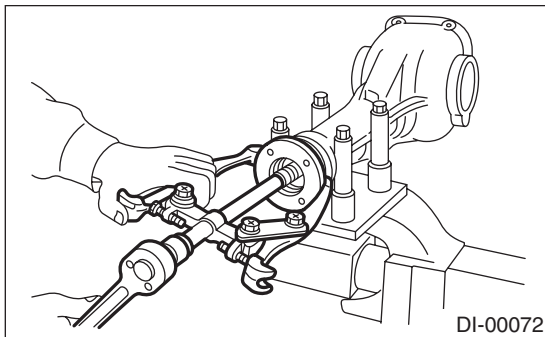

14) Press the end of drive pinion shaft and extract it together with rear bearing cone, preload adjusting spacer and washer.

NOTE:

Hold the drive pinion so as not to drop it.

ST 398467700 DRIFT

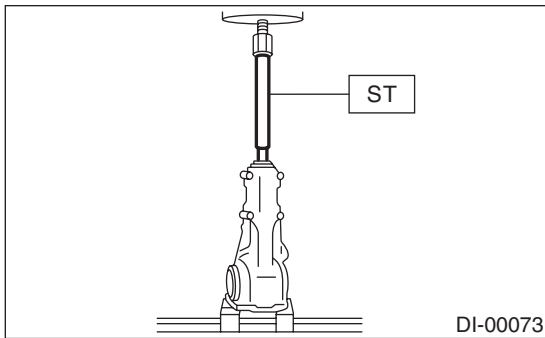

15) Remove rear bearing cone from drive pinion by supporting cone with ST.

NOTE:

Place the replacer so that its center-recessed side faces the pinion gear.

ST 398517700 REPLACER

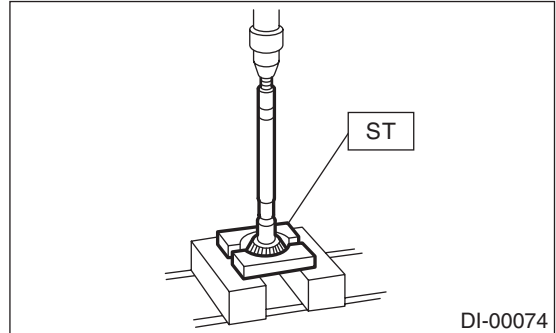

16) Remove front oil seal from differential carrier using ST.

ST 398527700 PULLER ASSY

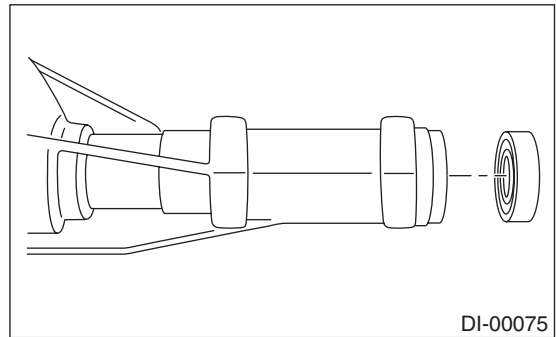

17) Remove pilot bearing together with front bearing cone using ST.

ST 398467700 DRIFT

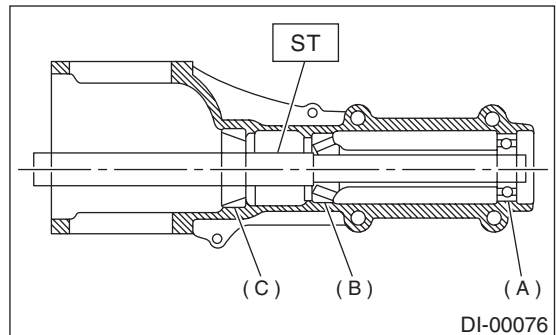

- (A) Pinion bearing
- (B) Front bearing
- (C) Rear bearing cup

18) When replacing bearings, tap front bearing cup and rear bearing cup in this order out of case by using a brass bar.

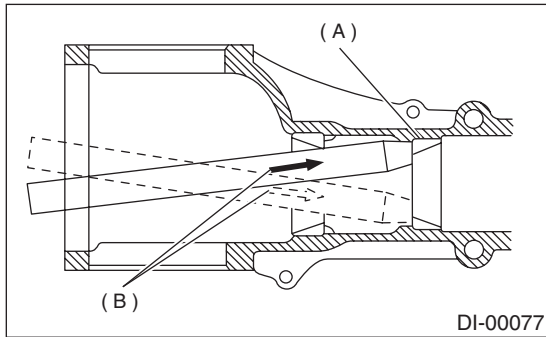

- (A) 2 cutouts along diagonal lines
- (B) Tap alternately with brass bar.

D: ASSEMBLY

NOTE:

- Assemble in the reverse order of disassembling.
- Check and adjust each part during assembly.
- Keep the shims and washers in order, so that they are not misinstalled.
- Thoroughly clean the surfaces on which the shims, washers and bearings are to be installed.
- Apply gear oil when installing the bearings and thrust washers.
- Be careful not to mix up the right and left hand races of the bearings.
- Replace the oil seal with new one at every disassembly. Apply chassis grease between the lips when installing the oil seal.

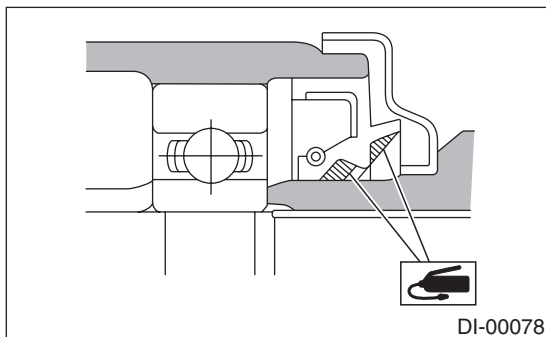

- Use new O-ring and gasket.

- 1) Adjusting preload for front and rear bearings
 - Adjust the bearing preload with spacer and washer between front and rear bearings.
 - Pinion height adjusting washer are not affected by this adjustment.
 - The adjustment must be carried out without oil seal inserted.

(1) Press rear bearing race rear into differential carrier with ST1 and ST2.

- ST1 398477701 HANDLE
- ST2 398477703 DRIFT 2

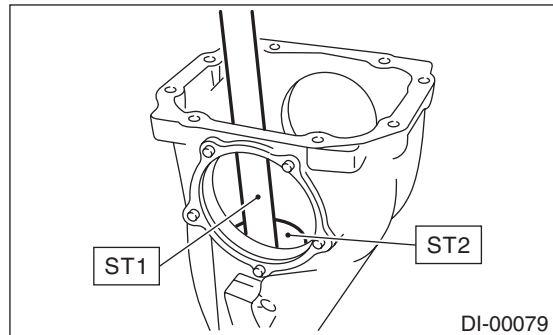

(2) Install rear bearing race (front) in differential carrier using ST1 and ST2.

- ST1 398477701 HANDLE
- ST2 398477702 DRIFT

(3) Measure and record the thickness of pinion height adjusting washer.

NOTE:

The used washer can be used after checking that it is not deformed when the tooth contact of drive gear and driven gear is correct during pre-disassembly.

(4) Insert ST1 into carrier with pinion height adjusting washer and new rear bearing cone fitted onto it.

REAR DIFFERENTIAL FOR T-TYPE

DIFFERENTIALS

(5) Then install preload adjusting spacer and washer, front bearing cone, ST2, companion flange, and washer and drive pinion nut.

ST1 398507702 DUMMY SHAFT
 ST2 398507703 DUMMY COLLAR

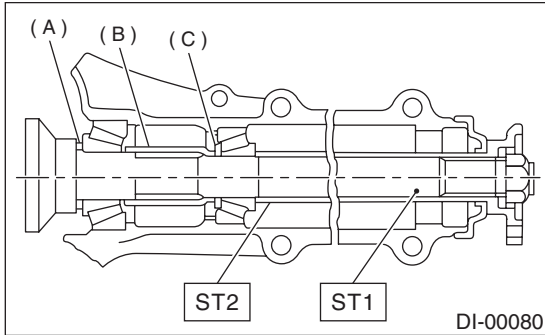

- (A) Pinion height adjusting shim
- (B) Preload adjusting spacer
- (C) Preload adjusting washer

(6) Turn ST1 with hand to make it seated, and tighten drive pinion nut while measuring the preload with spring balance. Select preload adjusting washer and spacer so that the specified preload is obtained when nut is tightened to the specified torque.

NOTE:

- Use a new lock nut.
- Be careful not to give excessive preload.
- When tightening the drive pinion nut, lock ST2 with ST1 as shown in the figure.

ST1 398507704 BLOCK
 ST2 398507702 DUMMY SHAFT

Tightening torque:
181 N·m (18.5 kgf·m, 134 ft·lb)

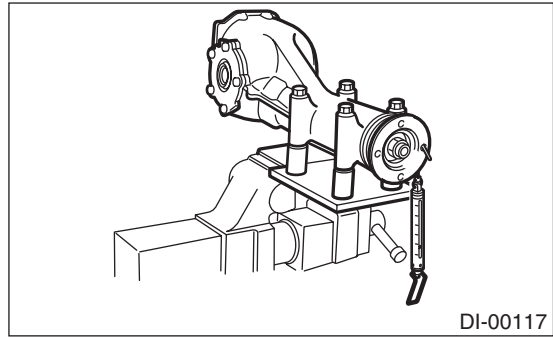
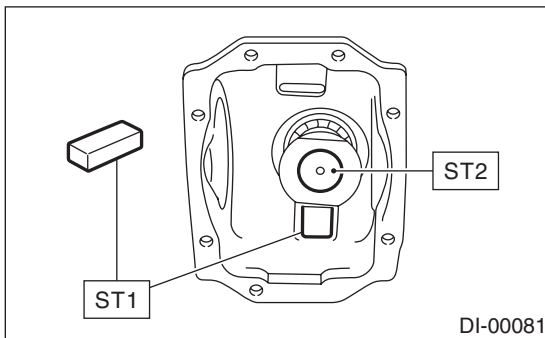

Preload adjusting washer	Part No.	Thickness mm (in)
	383705200	2.59 (0.1020)
	383715200	2.57 (0.1012)
	383725200	2.55 (0.1004)
	383735200	2.53 (0.0996)
	383745200	2.51 (0.0988)
	383755200	2.49 (0.0980)
	383765200	2.47 (0.0972)
	383775200	2.45 (0.0965)
	383785200	2.43 (0.0957)
	383795200	2.41 (0.0949)
	383805200	2.39 (0.0941)
	383815200	2.37 (0.0933)
383825200	2.35 (0.0925)	
383835200	2.33 (0.0917)	
383845200	2.31 (0.0909)	
Preload adjusting spacer	Part No.	Length mm (in)
	383695201	56.2 (2.213)
	383695202	56.4 (2.220)
	383695203	56.6 (2.228)
	383695204	56.8 (2.236)
	383695205	57.0 (2.244)
383695206	57.2 (2.252)	

Front and rear bearing preload
For new bearing: 18.1 — 38.8 N (1.8 — 4.0 kgf, 4.1 — 8.71 lb) at companion flange bolt hole

REAR DIFFERENTIAL FOR T-TYPE

DIFFERENTIALS

2) Adjusting drive pinion height

Adjust drive pinion height with shim installed between rear bearing cone and the back of pinion gear.

(1) Set ST2.

- ST1 398507702 DUMMY SHAFT
- ST2 398507701 DIFFERENTIAL CARRIER GAUGE
- ST3 398507703 DUMMY COLLAR

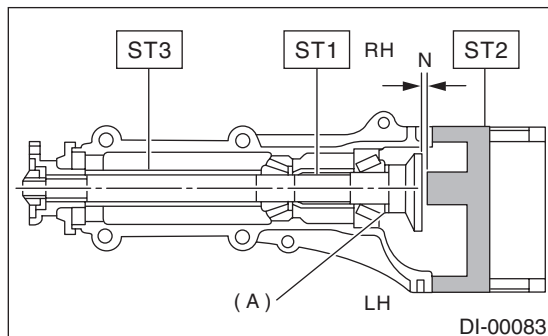

(A) Pinion height adjusting shim

(2) Measure the clearance N between the end of ST2 and the end surface of ST1 by using a thickness gauge.

NOTE:

Make sure there is no clearance between the case and ST2.

- ST1 398507702 DUMMY SHAFT
- ST2 398507701 DIFFERENTIAL CARRIER GAUGE

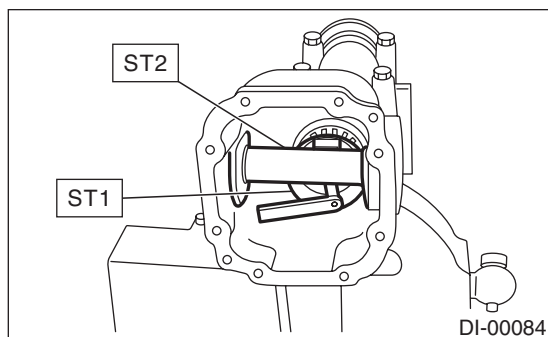

(3) Obtain the thickness of pinion height adjusting shim to be inserted from the following formula, and replace the temporarily installed shim with this one.

$$T = T_o + N - (H \times 0.01) - 0.20 \text{ mm (0.0079 in)}$$

NOTE:

Use copies of this page.

T	Thickness of pinion height adjusting shim mm (in)	
To	Thickness of shim temporarily inserted mm (in)	
N	Reading of thickness gauge mm (in)	
H	Figure marked on drive pinion head	
Memo:		

(Example of calculation)

$$T_o = 2.20 + 1.20 = 3.40 \text{ mm}$$

$$N = 0.23 \text{ mm}$$

$$H = + 1$$

$$T = 3.40 + 0.23 - 0.01 - 0.20 = 3.42$$

$$\text{Result: Thickness} = 3.42 \text{ mm}$$

Therefore use the shim 383605200.

Pinion height adjusting shim	
Part No.	Thickness mm (in)
383495200	3.09 (0.1217)
383505200	3.12 (0.1228)
383515200	3.15 (0.1240)
383525200	3.18 (0.1252)
383535200	3.21 (0.1264)
383545200	3.24 (0.1276)
383555200	3.27 (0.1287)
383565200	3.30 (0.1299)
383575200	3.33 (0.1311)
383585200	3.36 (0.1323)
383595200	3.39 (0.1335)
383605200	3.42 (0.1346)
383615200	3.45 (0.1358)
383625200	3.48 (0.1370)
383635200	3.51 (0.1382)
383645200	3.54 (0.1394)
383655200	3.57 (0.1406)
383665200	3.60 (0.1417)
383675200	3.63 (0.1429)
383685200	3.66 (0.1441)

REAR DIFFERENTIAL FOR T-TYPE

DIFFERENTIALS

3) Install the selected pinion height adjusting shim on drive pinion, and press the rear bearing cone into position with ST.

ST 398177700 INSTALLER

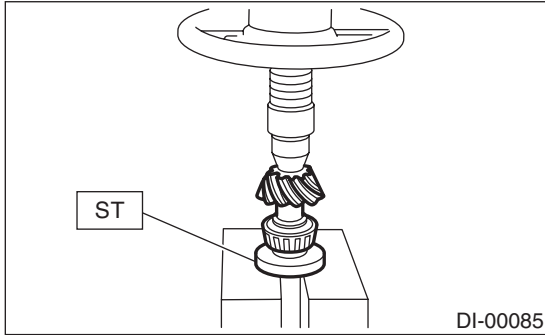

4) Insert drive pinion into differential carrier, install the previously selected bearing preload adjusting spacer and washer.

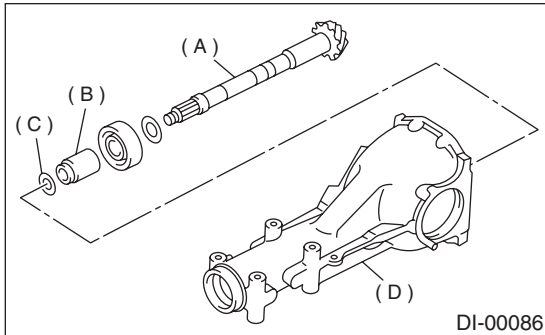

- (A) Drive pinion
- (B) Bearing adjusting spacer
- (C) Bearing adjusting washer
- (D) Differential carrier

5) Press-fit front bearing cone into case with ST1, ST2 and ST3.

ST1 398507703 DUMMY COLLAR
ST2 399780104 WEIGHT
ST3 899580100 INSTALLER

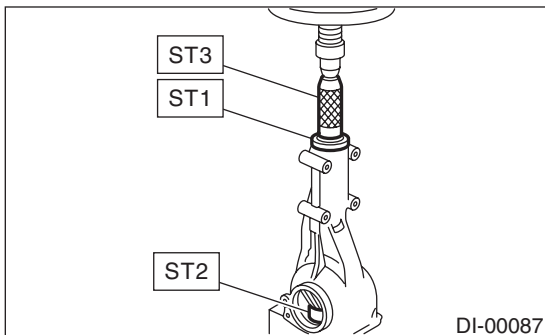

6) Insert spacer, then press-fit pilot bearing with ST1 and ST2.

ST1 399780104 WEIGHT
ST2 899580100 INSTALLER

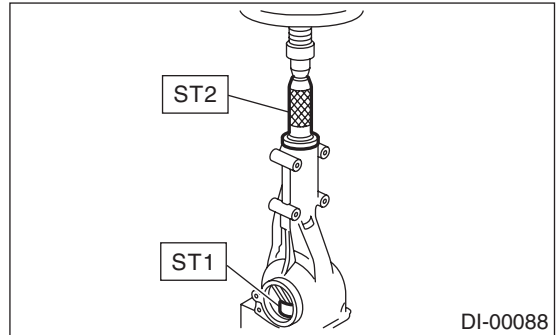

7) Fit a new oil seal with ST.

NOTE:

- Press-fit until end of oil seal is 1 mm (0.04 in) inward from end of carrier.
- Apply grease between the oil seal lips.

ST 498447120 OIL SEAL INSTALLER

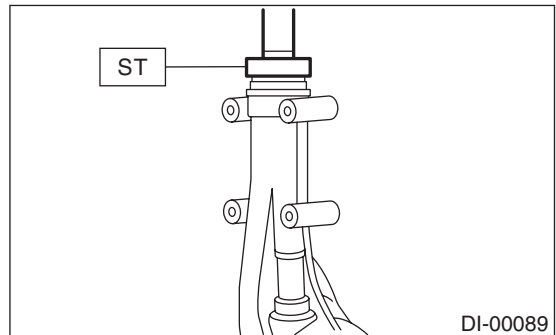

8) Press-fit companion flange with ST1 and ST2.

NOTE:

Be careful not to damage bearing.

ST1 899874100 INSTALLER
ST2 399780104 WEIGHT

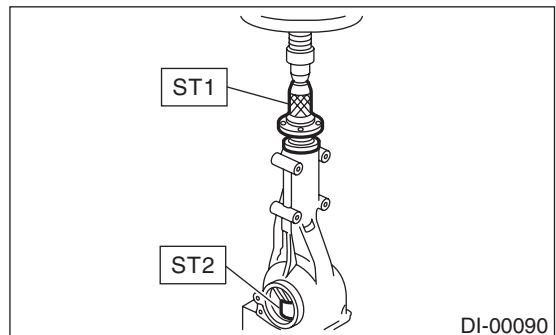

9) Install new self-locking nut. Then fix and tighten companion flange with ST.

ST 498427200 FLANGE WRENCH

Tightening torque:

181 N·m (18.5 kgf·m, 134 ft·lb)

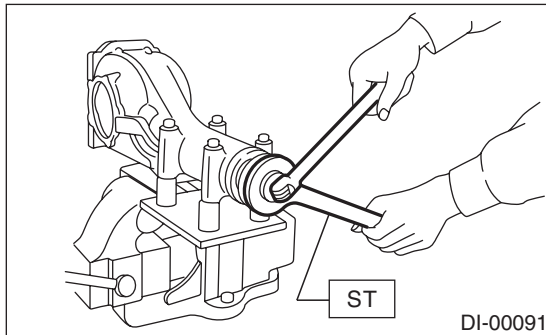

10) Install crown gear on differential case.

NOTE:

- Before installing bolts, apply Lock Tite to bolt threads.

Lock Tite:

THREE BOND 1324 (Part No. 004403042) or equivalent

- Tighten diagonally while tapping the bolt heads.

Tightening torque:

105 N·m (10.7 kgf·m, 77.4 ft·lb)

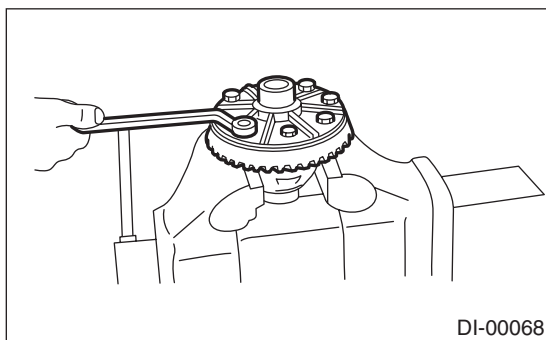

11) Press side bearing onto differential case with ST.

ST 398237700 DRIFT

NOTE:

When replacing bearing cone, replace it with bearing cap as a set.

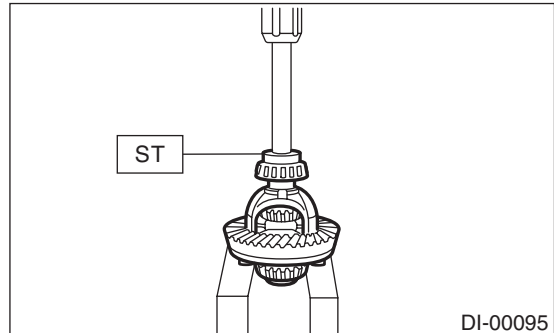

12) Install bearing cup to side bearing retainer.

NOTE:

- Press in while be careful not to scratch bearing cup and side bearing retainer.
- When replacing bearing cup, replace it with bearing cone as a set.

13) Using ST, press in new oil seal to side bearing retainer.

ST 398437700 DRIFT

NOTE:

Apply thin oil gear oil on the mating surface of side bearing retainer and oil seal.

14) Adjusting side bearing retainer shims

- (1) The driven gear backlash and side bearing preload can be determined by the side bearing retainer shim thickness.
- (2) Install the differential case assembly into differential carrier in the reverse order of disassembly.

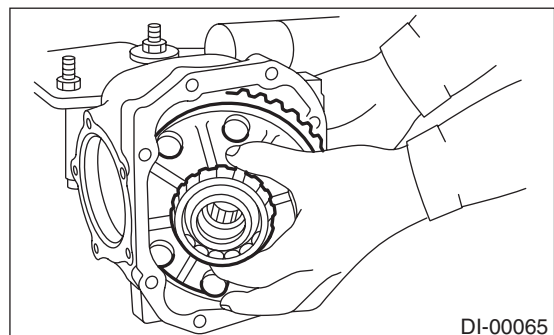

REAR DIFFERENTIAL FOR T-TYPE

DIFFERENTIALS

(3) Install side retainer shims to the left and right retainers from which they were removed.

NOTE:

Replace broken or corroded side retainer shim with new one of same thickness.

Side bearing retainer shim	
Part No.	Thickness mm (in)
383475201	0.20 (0.0079)
383475202	0.25 (0.0098)
383475203	0.30 (0.0118)
383475204	0.40 (0.0157)
383475205	0.50 (0.0197)

(4) Align arrow marked on differential carrier with that marked on side retainer during installation.

NOTE:

Be careful that side bearing outer race is not damaged by bearing roller.

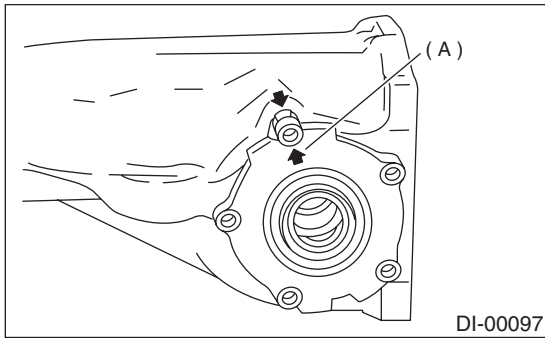

(A) Arrow mark

(5) Tighten side bearing retainer bolts.

Tightening torque:

10.3 N·m (1.05 kgf·m, 7.6 ft·lb)

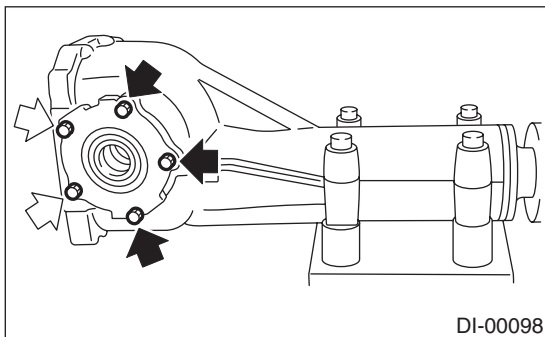

DI-00098

(6) Measure the crown gear-to-drive pinion backlash. Set magnet base on differential carrier. Align contact point of dial gauge with tooth face of crown gear, and move crown gear while holding drive pinion still. Read value indicated on dial gauge.

If the measured backlash is not within the specified range, adjust side bearing retainer shims as follows:

Backlash is over 0.2 mm (0.008 in):

Reduce the shim thickness of crown gear back-side and increase crown gear tooth-side.

Backlash is less than 0.1 mm (0.004 in):

Increase the shim thickness of crown gear back-side and reduce crown gear tooth-side.

Backlash:

0.10 — 0.20 mm (0.0039 — 0.0079 in)

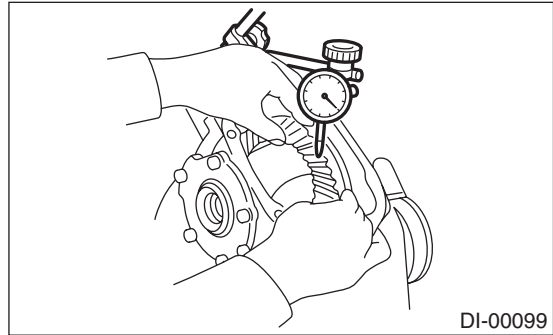

DI-00099

(7) At the same time, measure the turning resistance of drive pinion. Compare with the resistance when differential case is not installed, if the increase of the resistance is not within the specified range, adjust thickness of side bearing retainer shims so that the back- and tooth-sides are the same thickness.

Turning resistance increase:

20.7 — 54.4 N (2.1 — 5.5 kgf, 4.7 — 12.2 lb)

15) Re-check crown gear-to-pinion backlash.

Backlash:

0.10 — 0.20 mm (0.0039 — 0.0079 in)

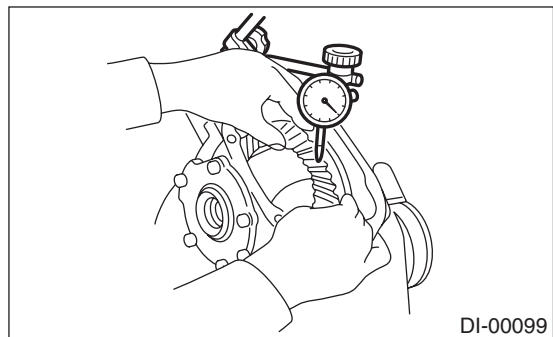

DI-00099

16) Check the crown gear runout on its back surface, and make sure pinion and crown gear rotate smoothly.

Limit of runout:

Less than 0.05 mm (0.0020 in)

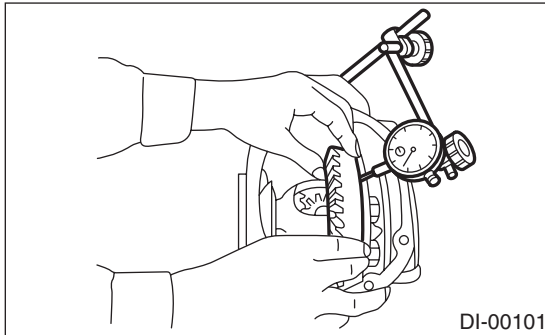

- Face contact

Checking item: Backlash is too large.

Contact pattern

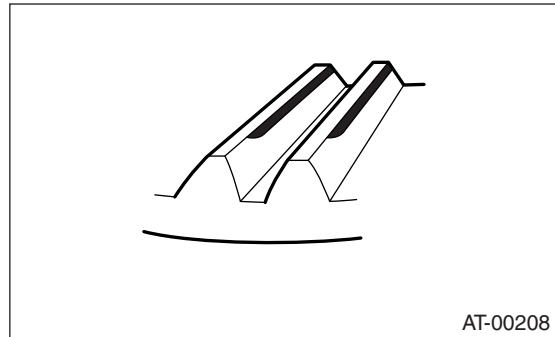

Corrective action: Increase thickness of drive pinion height adjusting shim in order to bring drive pinion close to crown gear.

17) Checking and adjusting tooth contact of crown gear

(1) Apply an even coat of red lead on both sides of three or four teeth on the crown gear. Check the contact pattern after rotating crown gear several revolutions back and forth until a definite contact pattern appears on the crown gear.

(2) When the contact pattern is incorrect, readjust according to the instructions given in "TOOTH CONTACT PATTERN".

NOTE:

Be sure to wipe off red lead completely after adjustment is completed.

- Correct tooth contact

Checking item: Tooth contact pattern is slightly shifted toward to toe side under no-load rotation. (When loaded, contact pattern moves toward heel)

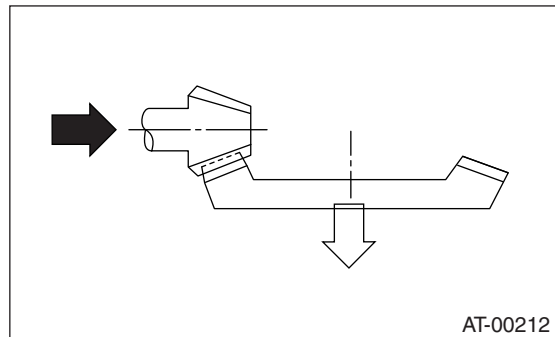

- Flank contact

Checking item: Backlash is too small.

Contact pattern

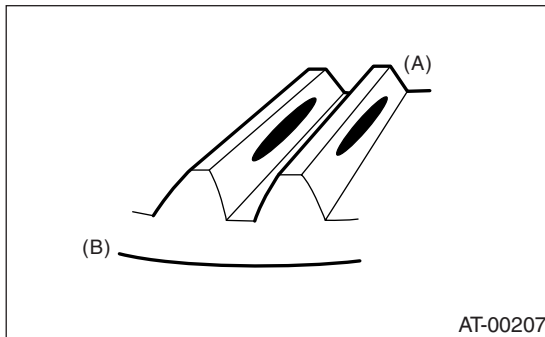
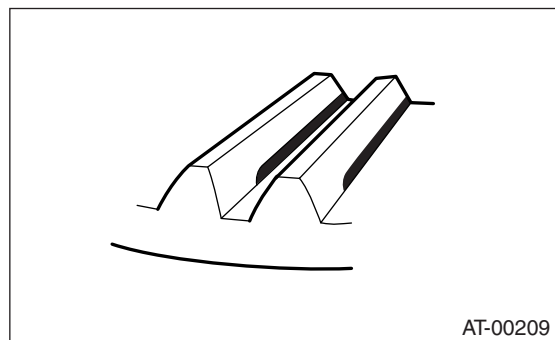

- (A) Toe side
- (B) Heel side

REAR DIFFERENTIAL FOR T-TYPE

DIFFERENTIALS

Corrective action: Reduce thickness of drive pinion height adjusting shim in order to move drive pinion away from crown gear.

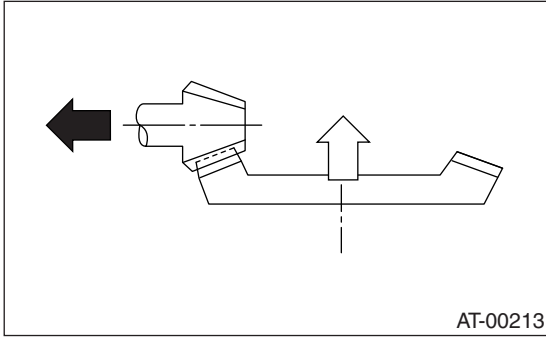

• Toe contact (Inside end contact)
Checking item: Contact area is small.
 Contact pattern

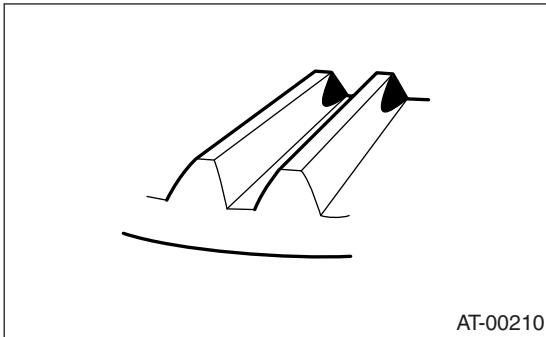

Corrective action: Reduce thickness of drive pinion height adjusting shim in order to move drive pinion away from crown gear.

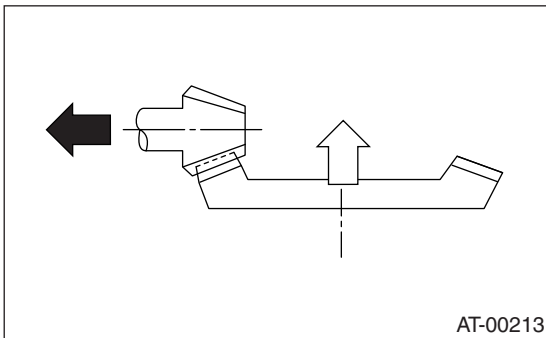

• Heel contact (Outside end contact)
Checking item: Contact area is small.
 Contact pattern

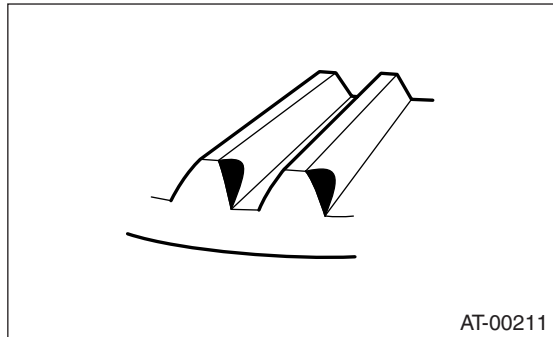

Corrective action: Increase thickness of drive pinion height adjusting shim in order to bring drive pinion close to crown gear.

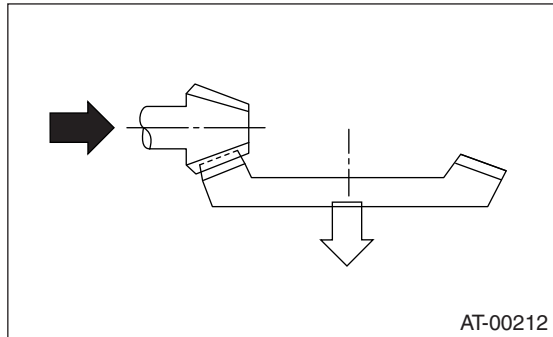

18) If proper tooth contact is not obtained, once again adjust the drive pinion height changing RH and LH side bearing retainer shims and the hypoid gear backlash.

19) Remove left and right side retainer.

20) Install left and right side bearing retainer, new O-rings and side retainer shims.

21) Align the arrow mark on differential carrier with the mark on side retainer during installation.

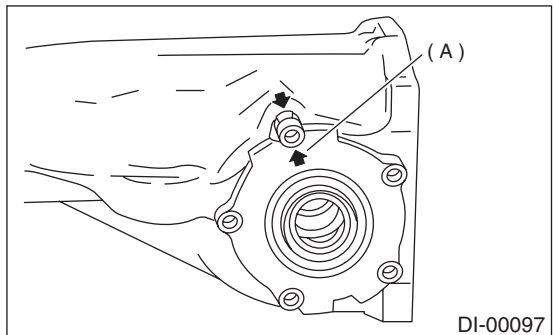

(A) Arrow mark

22) Tighten the side bearing retainer bolts.

Lock Tite:

THREE BOND 1105 (Part No. 004403010) or equivalent

Tightening torque:

10.3 N·m (1.05 kgf-m, 7.6 ft-lb)

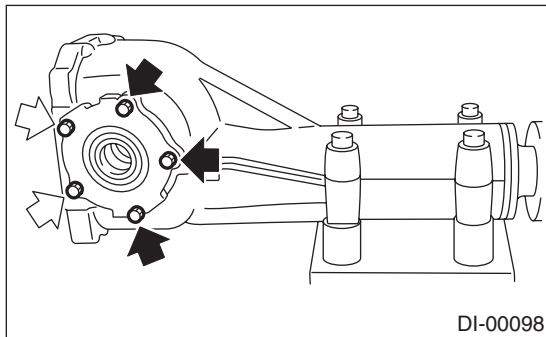

23) Install new gasket and rear cover, and tighten bolts to specified torque.

Tightening torque:

29 N·m (3.0 kgf-m, 21.7 ft-lb)

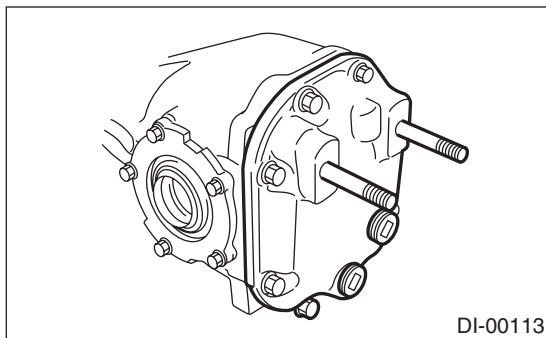

E: INSPECTION

Wash all the disassembled parts clean, and examine them for wear, damage, or other defects. Repair or replace defective parts as necessary.

1) Crown gear and drive pinion

- If abnormal tooth contact is evident, find out the cause and adjust to give correct tooth contact at assembly. Replace the gear if excessively worn or incapable of adjustment.

- If crack, score, or seizure is evident, replace as a set. Slight damage of tooth can be corrected by oil stone or the like.

2) Side gear and pinion mate gear

- Replace if crack, score, or other defects are evident on tooth surface.

- Replace if thrust washer contacting surface is worn or seized. Slight damage of the surface can be corrected by oil stone or the like.

3) Bearing

Replace if seizure, peeling, wear, rust, dragging during rotation, abnormal noise or other defect is evident.

4) Thrust washers of side gear and pinion mate gear

Replace if seizure, flaw, abnormal wear or other defect is evident.

5) Oil seal

Replace if deformed or damaged, and at every disassembling.

6) Differential carrier

Replace if the bearing bores are worn or damaged.

7) Differential case

Replace if its sliding surfaces are worn or cracked.

8) Companion flange

Replace if the oil seal lip contacting surfaces have flaws.

1. SIDE GEAR BACKLASH

Using a dial gauge, check the backlash of the side gear.

Side gear backlash:

0.1 — 0.2 mm (0.004 — 0.008 in)

If side gear backlash is not within the specification, adjust clearance as specified by selecting side gear thrust washer.

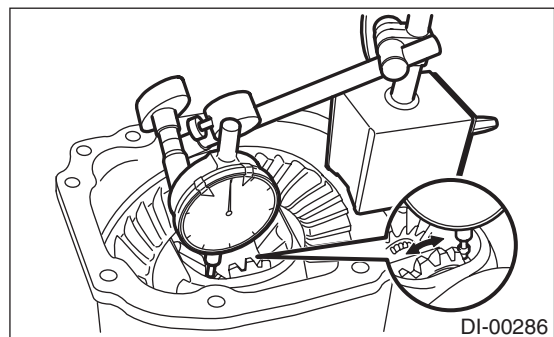

REAR DIFFERENTIAL FOR T-TYPE

DIFFERENTIALS

2. CROWN GEAR BACKLASH

Using a dial gauge, check the backlash of the crown gear.

Crown gear backlash:

0.1 — 0.2 mm (0.004 — 0.008 in)

If crown gear backlash is not within the specification, adjust the side bearing preload or repair if necessary.

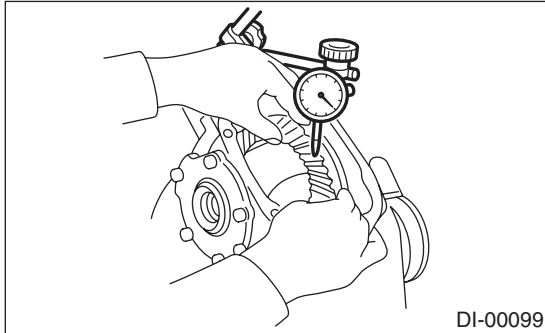

3. CROWN GEAR RUNOUT

Using a dial gauge, check the crown gear runout.

Crown gear runout:

Less than 0.05 mm (0.0020 in)

If the crown gear runout exceeds 0.05 mm (0.0020 in), replace the crown gear.

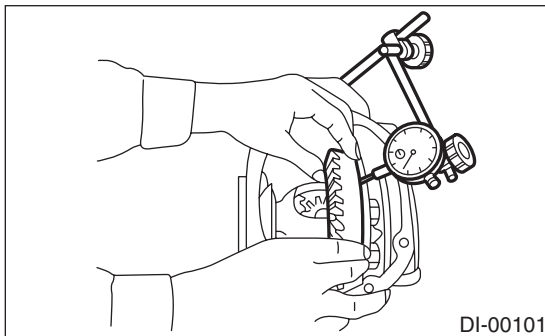

4. TOOTH CONTACT BETWEEN CROWN GEAR AND DRIVE PINION

Inspect tooth contact between crown gear and driven pinion. <Ref. to DI-29, ASSEMBLY, Rear Differential for T-type.>

5. TOTAL PRELOAD

Using a gauge, check the turning resistance increase.

Turning resistance increase:

2.9 — 10.8 N (0.3 — 1.1 kgf, 0.7 — 2.4 lb)

If the increase of the resistance is not within the specification, adjust the side bearing retainer shims.

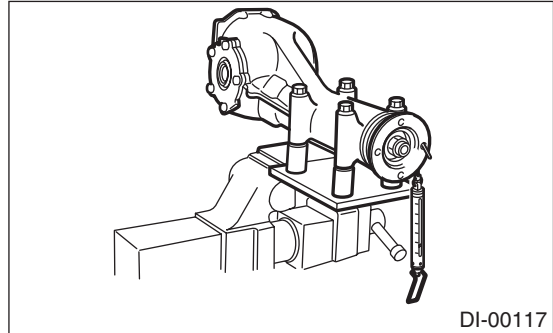

F: ADJUSTMENT

1. SIDE GEAR BACKLASH

Adjust side gear backlash.

<Ref. to DI-29, ASSEMBLY, Rear Differential for T-type.>

2. CROWN GEAR BACKLASH

Adjust crown gear backlash.

<Ref. to DI-29, ASSEMBLY, Rear Differential for T-type.>

3. TOOTH CONTACT BETWEEN CROWN GEAR AND DRIVE PINION

Adjust the tooth contact between crown gear and drive pinion gear.

<Ref. to DI-29, ASSEMBLY, Rear Differential for T-type.>

4. TOTAL PRELOAD

Adjust side bearing shim.

<Ref. to DI-29, ASSEMBLY, Rear Differential for T-type.>