

FRONT STRUT

FRONT SUSPENSION

5. Front Strut

A: REMOVAL

- 1) Set vehicle on a lift.
- 2) Disconnect ground cable from battery.
- 3) Lift-up the vehicle and remove the wheel.
- 4) Remove bolt securing brake hose to strut.

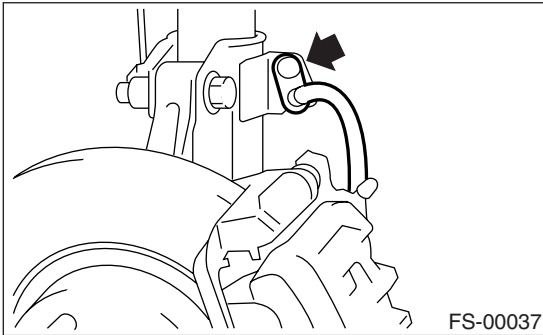

- 5) Scribe an alignment mark on the camber adjusting bolt which secures strut to housing.
- 6) Remove bolt securing the ABS sensor harness.

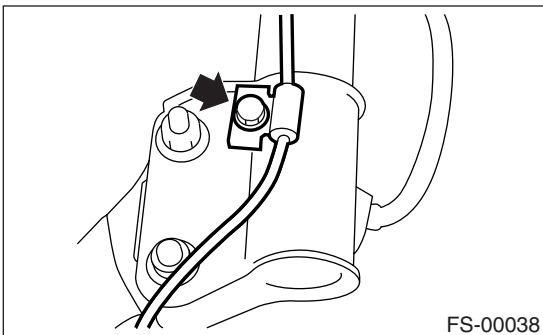

- 7) Remove two bolts securing housing to strut.

CAUTION:

While holding head of adjusting bolt, loosen self-locking nut.

- 8) Remove the three nuts securing strut mount to body.

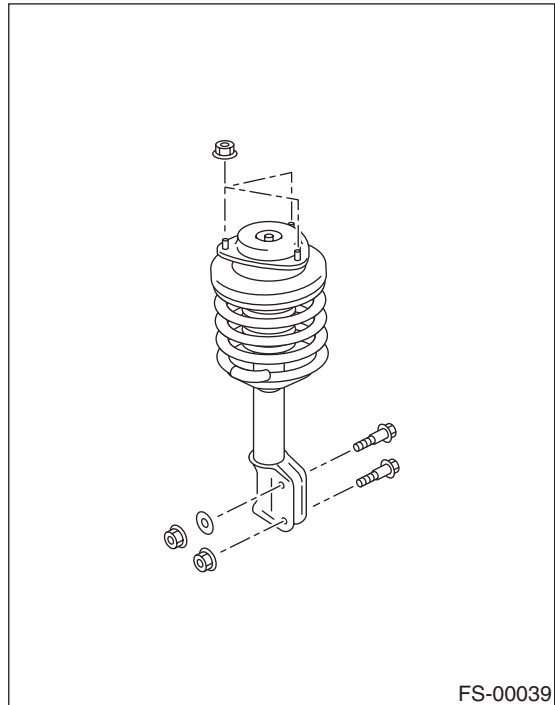

B: INSTALLATION

- 1) Install strut mount at upper side of strut to body and tighten with nuts.

Tightening torque:

20 N-m (2.0 kgf-m, 14.5 ft-lb)

- 2) Position aligning mark on camber adjustment bolt with aligning mark on lower side of strut.

CAUTION:

- While holding head of adjusting bolt, tighten self-locking nut.
- When self-locking nut is removed, replace with a new one.

Tightening torque:

152 N-m (16 kgf-m, 112 ft-lb)

- 3) Install ABS sensor harness to strut.

Tightening torque:

32 N-m (3.3 kgf-m, 23.9 ft-lb)

- 4) Install bolts which secure brake hose to strut.

Tightening torque:

32 N-m (3.3 kgf-m, 23.9 ft-lb)

- 5) Install wheels.

NOTE:

Check wheel alignment and adjust if necessary.

C: DISASSEMBLY

- 1) Using a coil spring compressor, compress coil spring.

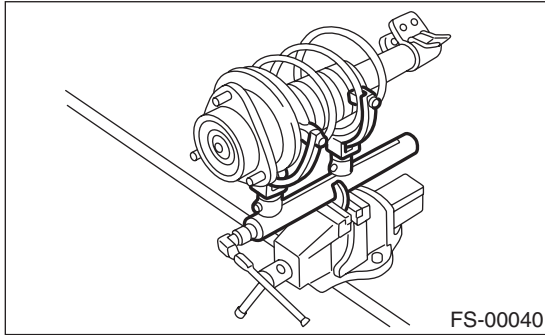

- 2) Using ST, remove self-locking nut.
ST 927760000 STRUT MOUNT SOCKET

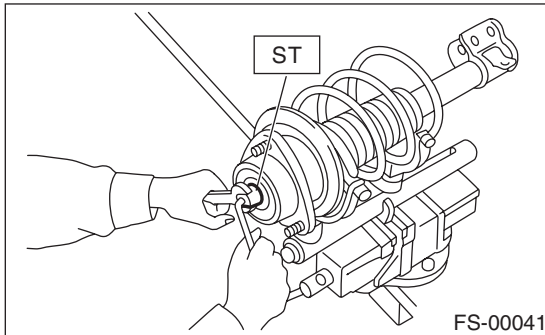

- 3) Remove strut mount, upper spring seat and rubber seat from strut.
- 4) Gradually decreasing compression force, and remove coil spring.
- 5) Remove dust cover and helper spring.

D: ASSEMBLY

- 1) Before installing coil spring, strut mount, etc., on the strut, check for the presence of air in the dampening force generating mechanism of the strut since air prevents proper dampening force from being produced.

- 2) Checking for the presence of air

- (1) Place the strut vertically with the piston rod facing up.
- (2) Move the piston rod to the center of its entire stroke.
- (3) While holding the piston rod end with fingertips, move the rod up and down.
- (4) If the piston rod moves at least 10 mm (0.39 in) in the former step, purge air from the strut.

- 3) Air purging procedure

- (1) Place the strut vertically with the piston rod facing up.
- (2) Fully extend the piston rod.
- (3) With the piston rod fully extended, place the piston rod side down. The strut must stand vertically.

- (4) Fully contract the piston rod.
- (5) Repeat 3 or 4 times from the first step.

NOTE:

After completely purging air from the strut, be sure to place the strut with the piston rod facing up. If it is laid down, check for entry of air in the strut as outlined under "Checking for the presence of air".

- 4) Using a coil spring compressor, compress the coil spring.

NOTE:

Make sure that the vertical installing direction of coil spring is as shown in figure.

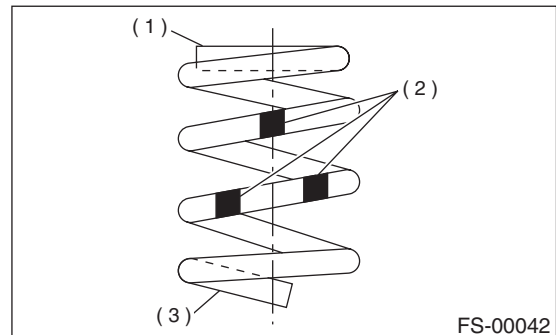

- (1) Flat (top side)
- (2) Identification paint
- (3) Inclined (bottom side)

- 5) Set the coil spring correctly so that its end face (1) fits well into the spring seat as shown in the figure.

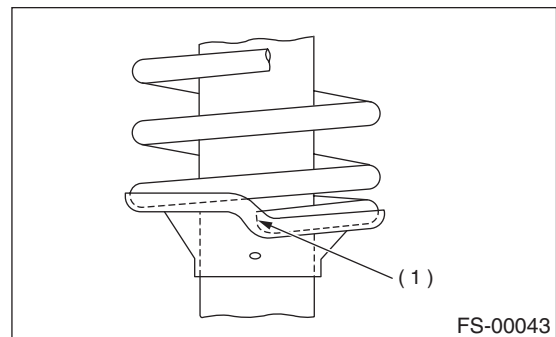

- 6) Install helper and dust cover to the piston rod.

FRONT STRUT

FRONT SUSPENSION

7) Pull the piston rod fully upward, and install rubber seat and upper spring seat.

NOTE:

Ensure that upper spring seat is positioned as shown in figure.

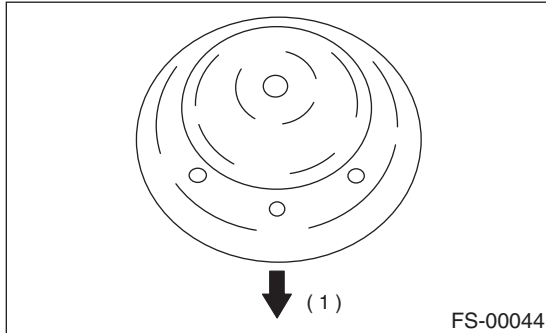

(1) Outside of body

8) Install strut mount to the piston rod, and tighten the self-locking nut temporarily.

CAUTION:

Be sure to use a new self-locking nut.

9) Using hexagon wrench to prevent strut rod from turning, tighten self-locking nut with ST.

ST 927760000 STRUT MOUNT SOCKET

Tightening torque:

55 N·m (5.6 kgf·m, 41 ft·lb)

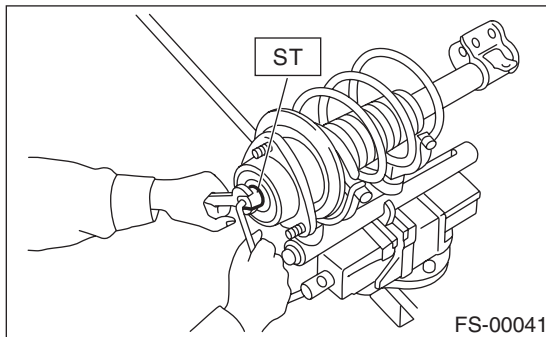

10) Loosen the coil spring carefully.

E: INSPECTION

Check the disassembled parts for cracks, damage and wear, and replace with new parts if defective.

1. DAMPER STRUT

1) Check for oil leakage.

2) Move the piston rod up and down to check it operates smoothly without any binding.

3) Play of piston rod

- Measure the play as follows:

Fix outer shell and fully extend the rod. Set a dial gauge at the end of the rod: L [10 mm (0.39 in)], then apply a force of W [20 N (2 kgf, 4 lb)] to threaded portion. With the force of 20 N (2 kgf, 4 lb) applied, read dial gauge indication: P₁. Apply a force of 20 N (2 kgf, 4 lb) in the opposite direction of "W", then read dial gauge indication: P₂.

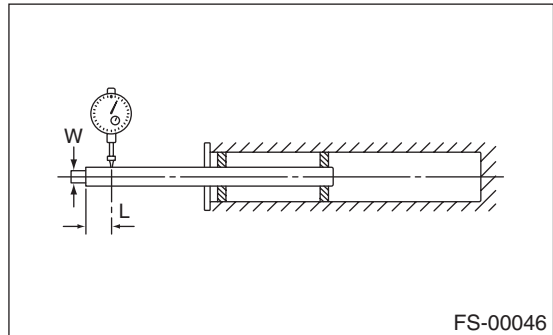

The free play is determined by the following equation:

$$\text{Play} = P_1, P_2$$

Standard of play:

Less than 0.8 mm (0.031 in)

If the play is greater than the standard, replace the strut.

2. STRUT MOUNT

Check rubber part for creep, cracks and deterioration, and replace it with new one if defective.

3. DUST COVER

If any cracks or damage are found, replace it with a new one.

4. COIL SPRING

One having permanent strain should be replaced with a new one. When vehicle posture is uneven, although there are no considerable reasons like tire puncture, uneven loading, etc., check coil spring for its free length referring to specifications, cracks, etc., and replace it with a new one if defective.

5. HELPER

Replace it with new one if cracked or damaged.

F: DISPOSAL**CAUTION:**

- Do not disassemble the strut damper or place it into a fire.
- Drill a hole before disposal of strut.
- Before handling gas filled struts, be sure to wear goggles to protect eyes from gas, oil and/or filings.

- 1) Place the gas filled strut (A) on a flat and level surface with piston rod (B) fully extended.
- 2) Using a 2 to 3 mm (0.08 to 0.12 in) dia. drill, make a hole in area shown in the figure.

