

3. Inspection Locations After a Collision

A: INSPECTION

If the vehicle is involved in a collision on any side, even if it is a slight collision, be sure to check the following system parts.

1. AIRBAG MODULE (DRIVER)

1) Check for the following, and replace damaged parts with new parts.

- Airbag module is cracked or deformed.
- Harness and/or connector is cracked, deformed or open. Lead wire is exposed.
- Mounting bracket is cracked or deformed.
- The module surface is fouled with grease, oil, water or cleaning solvent.

2) When installing a new driver's airbag module, check the following. If necessary, install a new airbag module and steering wheel.

- The clearance between the driver's airbag module and steering wheel is not constant.
- Free play of the steering wheel is over specifications in axial and radial directions.

Specifications:

Height deflection A

Less than 6 mm (0.24 in)

O.D. deflection L

Less than 7 mm (0.28 in) [Excluding steering offset 5 mm (0.20 in)]

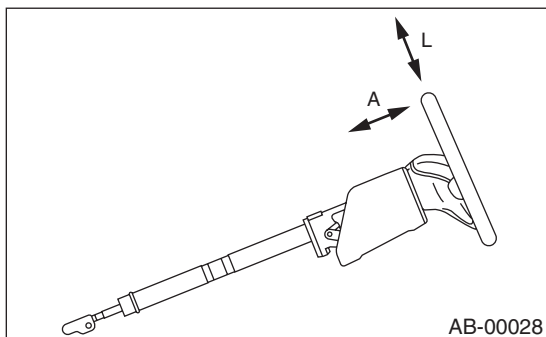

2. AIRBAG MODULE (PASSENGER)

Check for the following, and replace damaged parts with new parts.

- Airbag module is cracked or deformed.
- Harness and/or connector is cracked, deformed or open. Lead wire is exposed.
- Mounting bracket is cracked or deformed.
- The module surface is fouled with grease, oil, water or cleaning solvent.

3. AIRBAG CONTROL MODULE

Check for the following, and replace damaged parts with new parts.

- Control module is cracked or deformed.
- Mounting bracket is cracked or deformed.
- Connector is scratched or deformed.
- Airbag is deployed.

4. FRONT SUB SENSOR

If the front section of vehicle as shown in the figure is damaged:

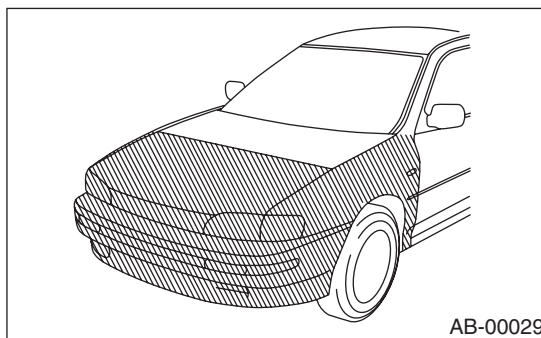

Check for the following, and replace damaged parts with new parts.

- Front sub sensor is cracked or deformed.
- Mounting bracket is cracked or deformed.
- Connector is scratched or cracked.
- Airbag is deployed.

5. FRONT SUB SENSOR HARNESS

Check for the following, and replace damaged parts with new parts.

- Harness is open, lead wire is exposed, and corrugated tube is noticeably cracked.
- Connector is scratched or cracked.

6. MAIN HARNESS

Check for the following, and replace damaged parts with new parts.

- Harness is open, lead wire is exposed, and corrugated tube is noticeably cracked.
- Connector is scratched or cracked.

7. ROLL CONNECTOR

Check for the following, and replace damaged parts with new parts.

- Combination switch or steering roll connector is cracked or deformed.

INSPECTION LOCATIONS AFTER A COLLISION

AIRBAG SYSTEM

8. STEERING SHAFT

Check for the following, and replace damaged parts with new parts.

The clearance between capsule (A) and tip of column bracket (B) on steering column upper side should be within specifications.

Specifications:

Clearance between capsule and tip of column bracket L

More than 1.3 mm (0.051 in)

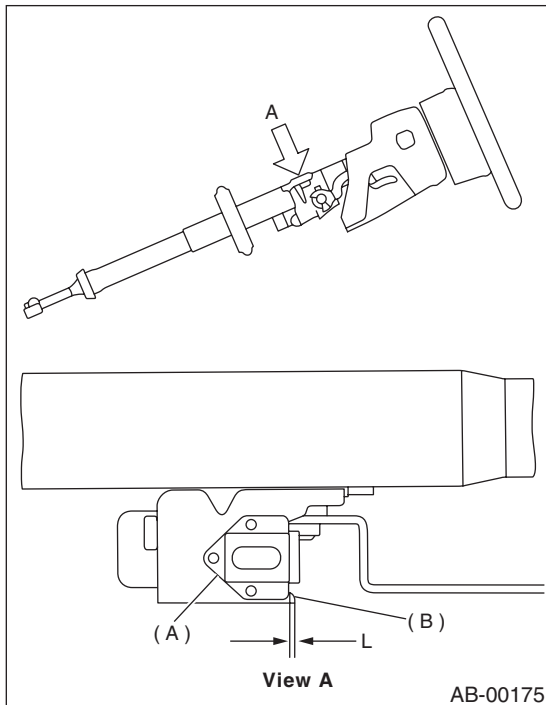

If necessary, replace them with new parts.