

DIAGNOSTIC PROCEDURE WITH SYMPTOM

CRUISE CONTROL SYSTEM (DIAGNOSTICS)

6. Diagnostic Procedure with Symptom

A: SYMPTOM CHART

Symptom		Repair area	Reference
1	Cruise control main switch is not turned to ON. (Cruise indicator light does not illuminate)	(1) Check the cruise indicator light.	<Ref. to CC(ETC)-12, CHECK CRUISE INDICATOR LIGHT, Diagnostic Procedure with Symptom.>
		(2) Check the cruise control command switch.	<Ref. to CC(ETC)-18, DTC 11, 15, 21 AND 24 CRUISE CONTROL SWITCH, Diagnostic Procedure with DTC.>
2	Cruise control cannot be set.	(1) Check the cruise control command switch	<Ref. to CC(ETC)-18, DTC 11, 15, 21 AND 24 CRUISE CONTROL SWITCH, Diagnostic Procedure with DTC.>
		(2) Check the stop light switch and brake switch.	<Ref. to CC(ETC)-22, DTC 12 AND 25 STOP LIGHT SWITCH AND BRAKE SWITCH, Diagnostic Procedure with DTC.>
		(3) Check the clutch switch.	<Ref. to CC(ETC)-24, DTC 13 CLUTCH SWITCH, Diagnostic Procedure with DTC.>
		(4) Check the neutral switch.	<Ref. to CC(ETC)-26, DTC 14 NEUTRAL POSITION SWITCH, Diagnostic Procedure with DTC.>
		(5) Check the vehicle speed sensor.	<Ref. to CC(ETC)-30, DTC 22 AND 32 VEHICLE SPEED SENSOR, Diagnostic Procedure with DTC.>
3	Cruise set indicator light does not illuminate.	Check the cruise set indicator light.	<Ref. to CC(ETC)-14, CHECK CRUISE SET INDICATOR LIGHT, Diagnostic Procedure with Symptom.>
4	Vehicle speed is not held within set speed ± 3 km/h (± 2 MPH).	Check the vehicle speed sensor.	<Ref. to CC(ETC)-30, DTC 22 AND 32 VEHICLE SPEED SENSOR, Diagnostic Procedure with DTC.>
5	Vehicle speed does not increase or does not return to set speed after RESUME/ACCEL switch has been pressed.	Check the RESUME/ACCEL switch.	<Ref. to CC(ETC)-18, DTC 11, 15, 21 AND 24 CRUISE CONTROL SWITCH, Diagnostic Procedure with DTC.>
6	Vehicle speed does not decrease after SET/COAST switch has been pressed.	Check the SET/COAST switch.	<Ref. to CC(ETC)-18, DTC 11, 15, 21 AND 24 CRUISE CONTROL SWITCH, Diagnostic Procedure with DTC.>
7	Cruise control is not released after CANCEL switch has been pressed.	Check the CANCEL switch.	<Ref. to CC(ETC)-18, DTC 11, 15, 21 AND 24 CRUISE CONTROL SWITCH, Diagnostic Procedure with DTC.>
8	Cruise control is not released after the brake pedal has been depressed.	Check the stop light switch and brake switch.	<Ref. to CC(ETC)-22, DTC 12 AND 25 STOP LIGHT SWITCH AND BRAKE SWITCH, Diagnostic Procedure with DTC.>
9	Cruise control is not released after the clutch pedal has been depressed.	Check the clutch switch.	<Ref. to CC(ETC)-24, DTC 13 CLUTCH SWITCH, Diagnostic Procedure with DTC.>
10	Cruise control is not released after shifting to neutral position.	Check the neutral switch.	<Ref. to CC(ETC)-26, DTC 14 NEUTRAL POSITION SWITCH, Diagnostic Procedure with DTC.>

DIAGNOSTIC PROCEDURE WITH SYMPTOM

CRUISE CONTROL SYSTEM (DIAGNOSTICS)

B: CHECK CRUISE INDICATOR LIGHT

TROUBLE SYMPTOM:

Cruise control can be set, but cruise indicator light does not illuminate.

WIRING DIAGRAM:

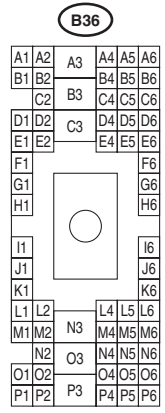
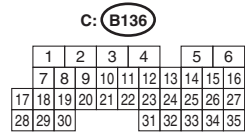
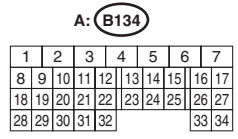
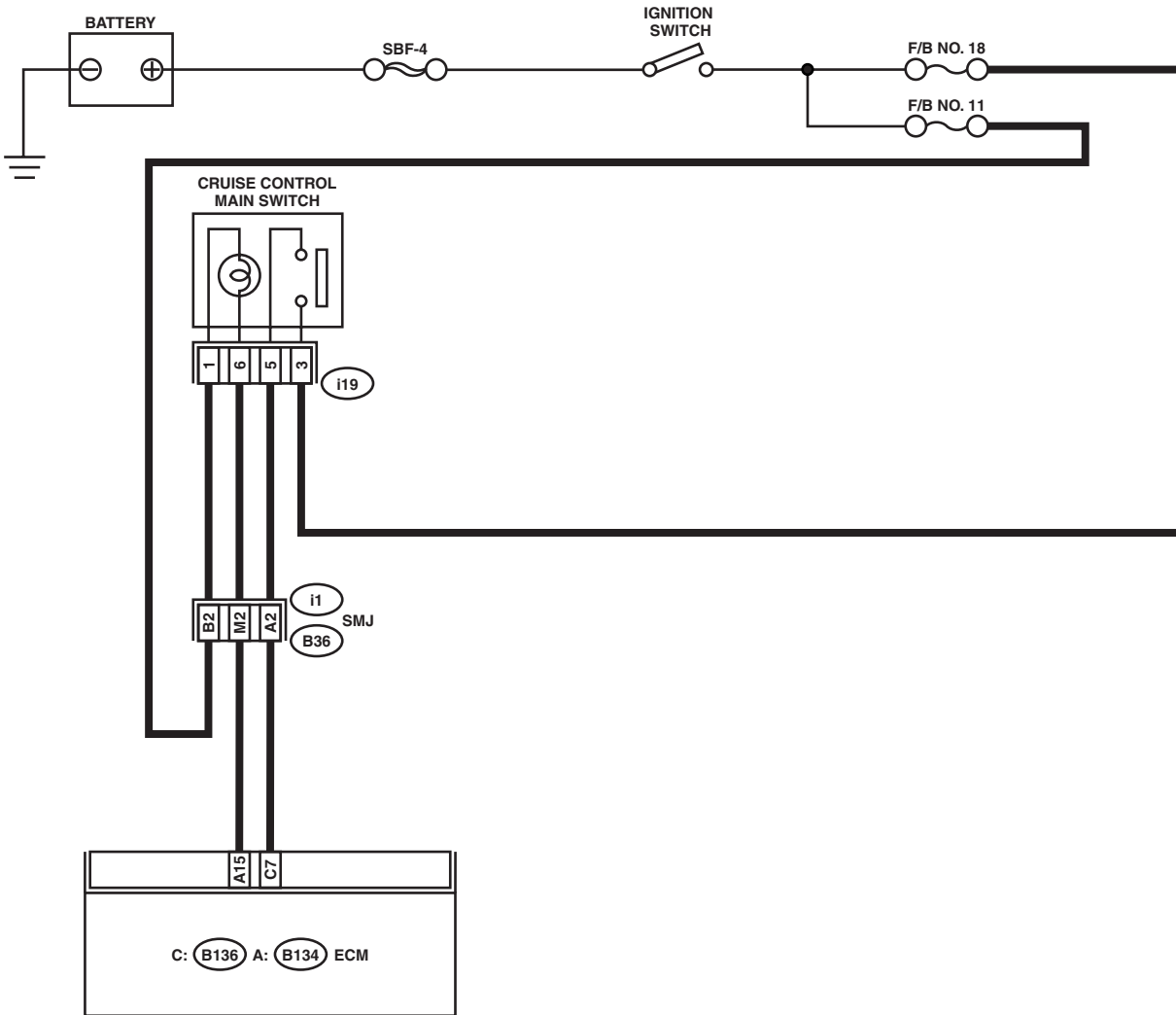

CC-00329

DIAGNOSTIC PROCEDURE WITH SYMPTOM

CRUISE CONTROL SYSTEM (DIAGNOSTICS)

Step	Check	Yes	No
1 CHECK CRUISE INDICATOR LIGHT CIRCUIT. 1) Turn the ignition switch to OFF. 2) Disconnect the cruise control main switch harness connector. 3) Turn the ignition switch to ON. 4) Measure the voltage between harness connector terminal and chassis ground. Connector & terminal <i>(i19) No. 1 (+) — Chassis ground (-):</i>	Is the voltage more than 10 V?	Go to step 2.	<ul style="list-style-type: none"> • Check the fuse No. 11 (in fuse & relay box). • Check the harness for open or short between cruise control main switch and fuse & relay box.
2 CHECK CRUISE INDICATOR LIGHT CIRCUIT. 1) Turn the ignition switch to OFF. 2) Disconnect the ECM harness connector. 3) Measure the resistance between ECM harness connector terminal and cruise control main switch harness connector terminal. Connector & terminal <i>(B134) No. 15 — (i19) No. 6:</i>	Is the resistance less than 10 Ω ?	Go to step 3.	Repair the harness.
3 CHECK CRUISE INDICATOR LIGHT CIRCUIT. Ground the ECM harness connector terminal with a suitable wire. Connector & terminal <i>(B134) No. 15 — Chassis ground:</i>	Does the cruise indicator light illuminate?	Check the poor contact of ECM connector.	Replace the cruise control main switch.

DIAGNOSTIC PROCEDURE WITH SYMPTOM

CRUISE CONTROL SYSTEM (DIAGNOSTICS)

C: CHECK CRUISE SET INDICATOR LIGHT

TROUBLE SYMPTOM:

Cruise control can be set, but cruise set indicator light does not illuminate.

WIRING DIAGRAM:

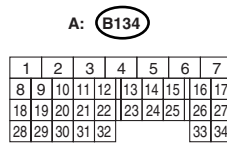
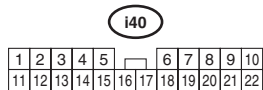
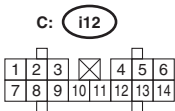
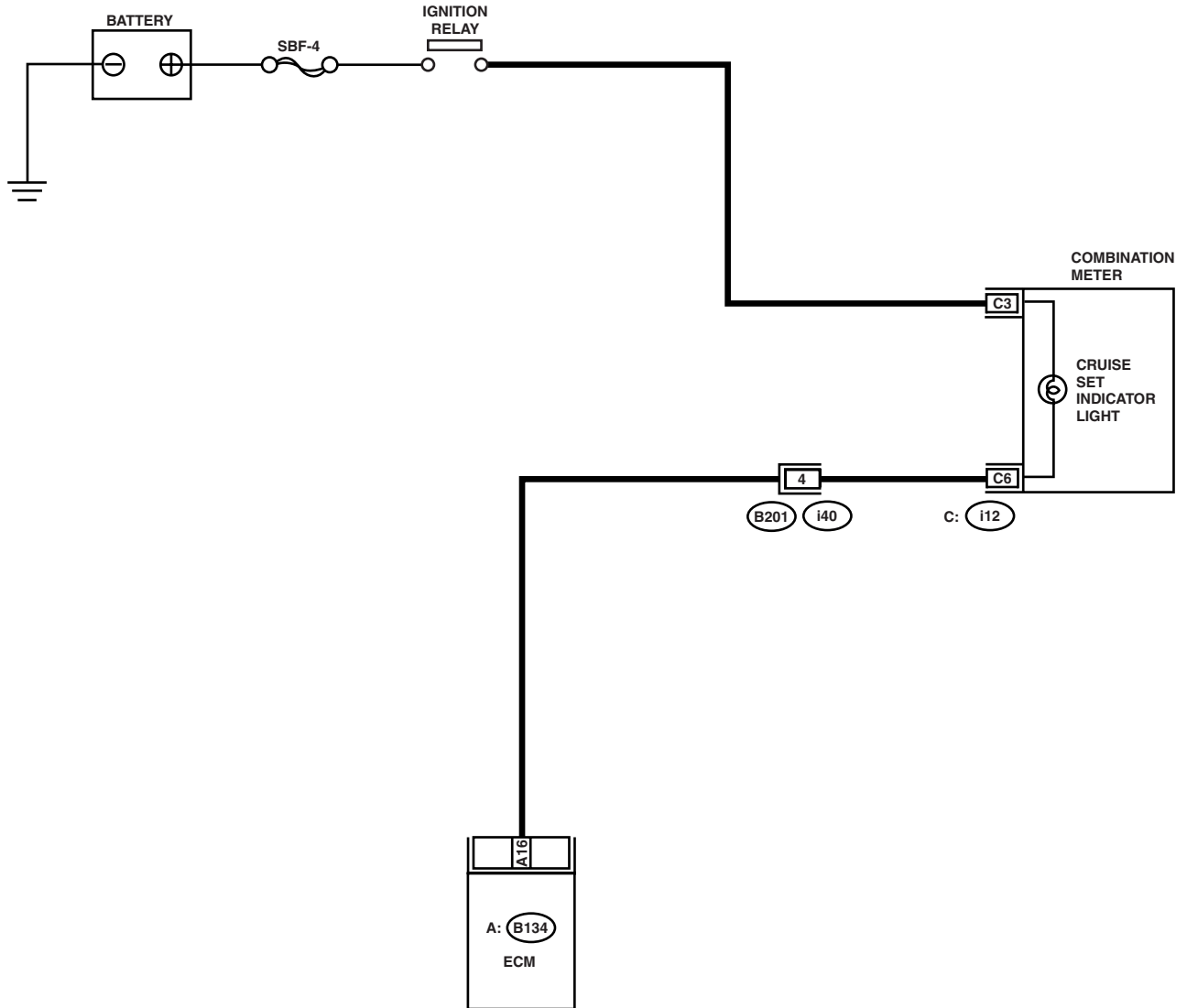

CC-00330

DIAGNOSTIC PROCEDURE WITH SYMPTOM

CRUISE CONTROL SYSTEM (DIAGNOSTICS)

Step	Check	Yes	No
1 CHECK CRUISE SET INDICATOR LIGHT CIRCUIT. 1) Turn the ignition switch to OFF. 2) Disconnect the combination meter harness connector. 3) Measure the voltage between harness connector terminal and chassis ground. Connector & terminal <i>(i12) No. 3 (+) — Chassis ground (-):</i>	Is the voltage more than 10 V?	Go to step 2.	Check the harness for open or short between combination meter and ignition relay.
2 CHECK CRUISE SET INDICATOR LIGHT CIRCUIT. 1) Turn the ignition switch to OFF. 2) Disconnect the ECM harness connector. 3) Measure the resistance between ECM harness connector terminal and combination meter harness connector terminal. Connector & terminal <i>(i12) No. 6 — (B134) No. 16:</i>	Is the resistance less than 10 Ω ?	Go to step 3.	Repair the harness.
3 CHECK CRUISE SET INDICATOR LIGHT CIRCUIT. Ground the ECM harness connector terminal with a suitable wire. Connector & terminal <i>(B134) No. 16 — Chassis ground:</i>	Does the cruise set indicator light illuminate?	Check the poor contact of ECM connector.	Replace the meter main assembly.