

26. Cargo Bed Upper Molding

A: REMOVAL

- 1) Remove cargo bed side tray. <Ref. to EI-46, REMOVAL, Cargo Bed Side Tray.>
- 2) Remove cargo bed side molding. <Ref. to EI-47, REMOVAL, Cargo Bed Side Molding.>
- 3) Remove cargo bed C pillar molding. <Ref. to EI-48, REMOVAL, Cargo Bed C Pillar Molding.>
- 4) Remove high-mounted stop light.

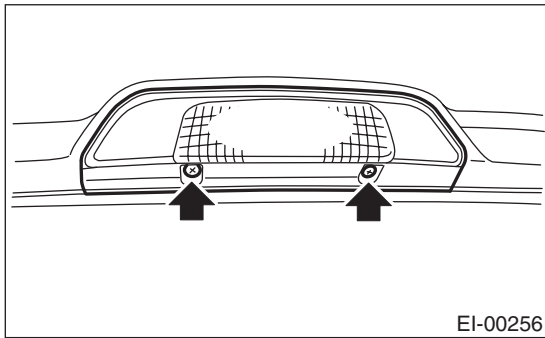

- 5) Remove cap and bolt using TORX® bit T25.

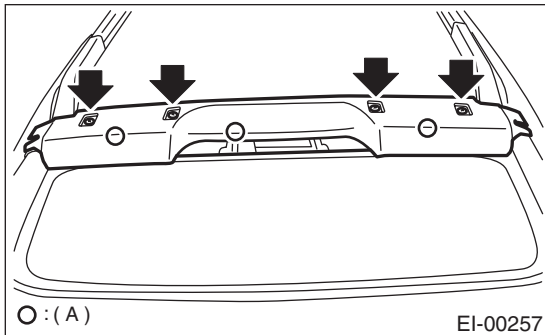

○ : (A) Clip

NOTE:

Do not reuse the removed clips; use new ones.

B: INSTALLATION

- 1) Replace all clips on the reverse of cargo bed upper molding with new ones.

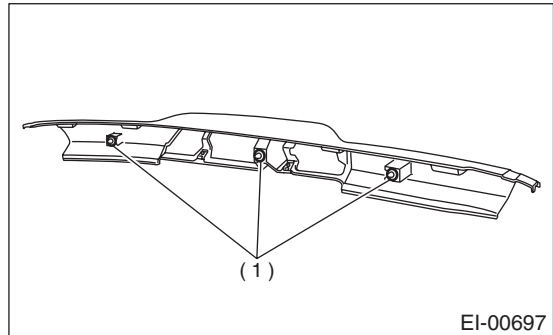

- 2) Install in the reverse order of removal.

Tightening torque:

- Cargo bed upper molding;**
7.5 N·m (0.76 kgf-m, 5.53 ft-lb)
- Cargo bed side molding;**
7.5 N·m (0.76 kgf-m, 5.53 ft-lb)
- Cargo bed side tray;**
7.5 N·m (0.76 kgf-m, 5.53 ft-lb)