

33. Tail Gate Molding

A: REMOVAL

- 1) Remove tail gate tray. <Ref. to EI-56, REMOVAL, Tail Gate Tray.>
- 2) Remove bolt using TORX® bit T25.

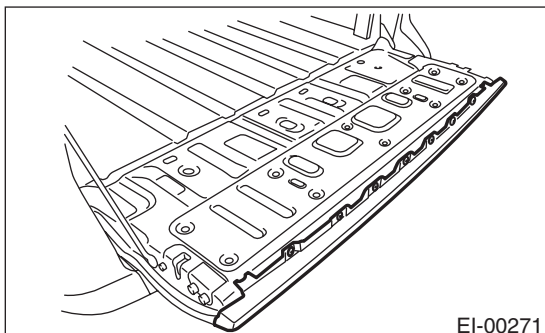

- 3) Remove clip and tail gate molding.

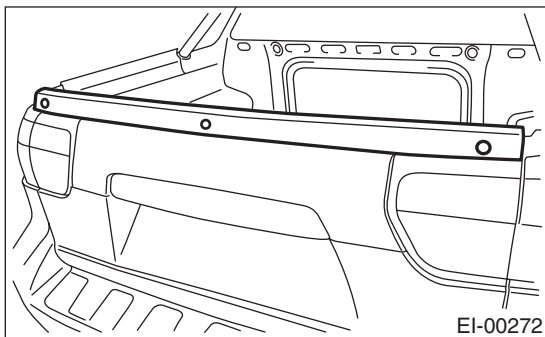

B: INSTALLATION

Install in the reverse order of removal.

NOTE:

Do not reuse the removed clips; use new ones.

Tightening torque:

7.5 N·m (0.76 kgf-m, 5.53 ft-lb)