

# 8. Protector

## A: REMOVAL

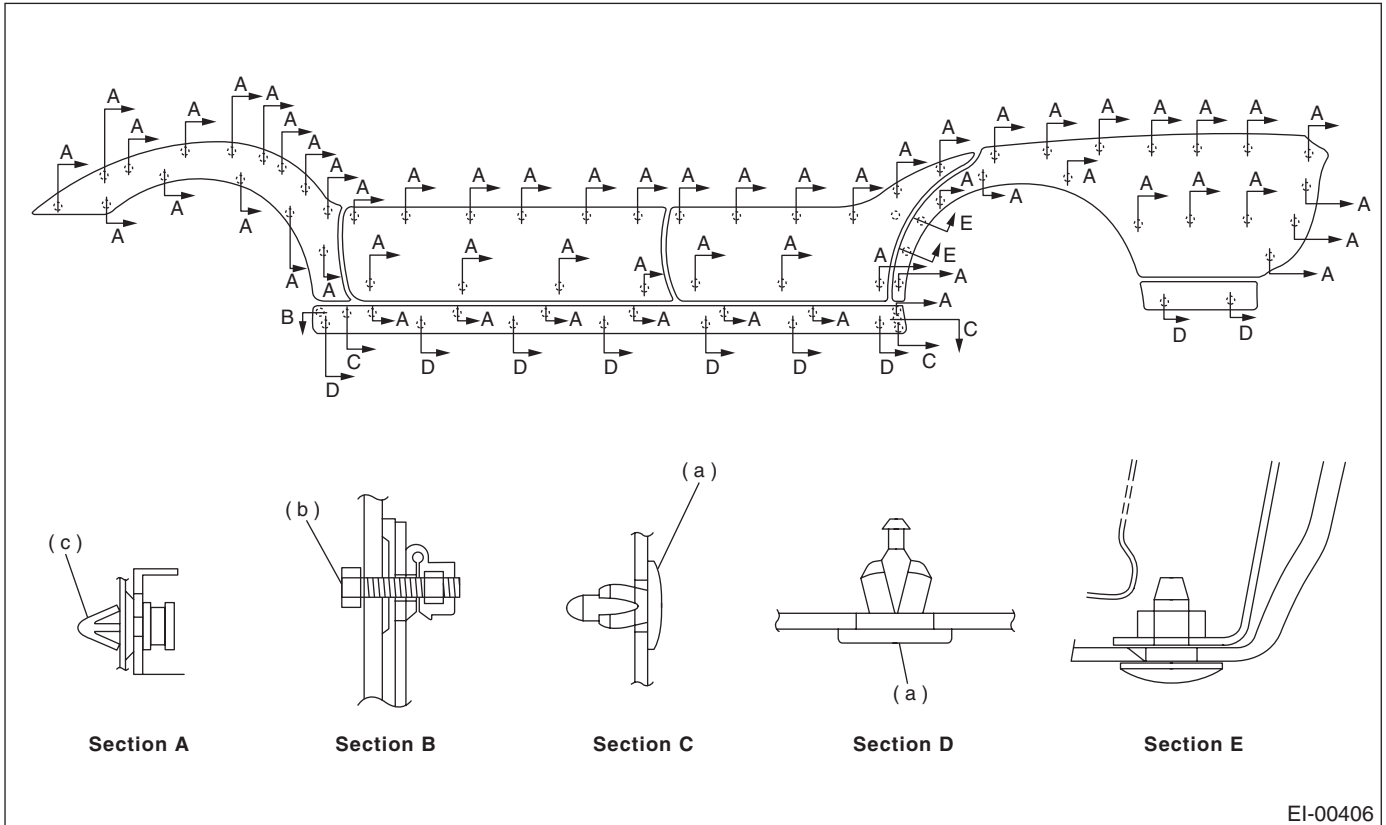

EI-00406

1) Attach masking tape to outer perimeter of side protector. (If original side protector is re-installed, tape the entire protector.)

2) Insert fishing line [0.8 mm (0.031 in) dia.] (A) between side protector (B) and vehicle body. Cut (pull the line) through two-sided tape (C) along side protector on the body. Using a puller, remove clips from vehicle body while pulling side protector towards yourself as required.

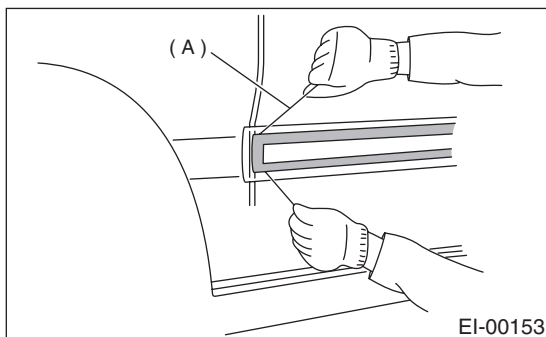

EI-00153

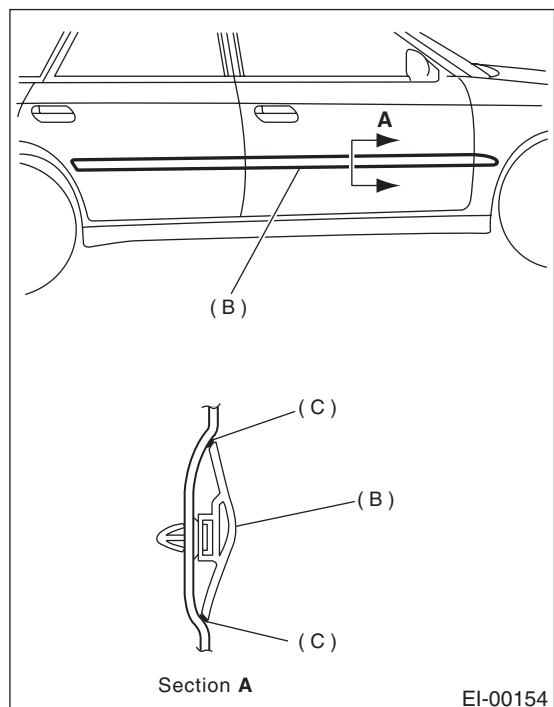

EI-00154

# PROTECTOR

## EXTERIOR/INTERIOR TRIM

### NOTE:

- To increase adhesive remover strength, leave two-sided tape on body and side protector.
- If two-sided tape is too thick, use a putty knife to cut it thin so that adhesive remover is ready for use.
- If two-sided tape is hard to remove, heat to approximately 40°C (104°F).

3) Apply an even coat of adhesive remover to the two-sided tape.

### Recommended adhesive remover:

**SUMITOMO 3M4000 or equivalent**

### CAUTION:

**Do not apply adhesive remover to lacquer base coated body panels.**

4) Attach plastic wrap (A) to adhesive remover coated areas and heat to 40 to 60°C (104 to 140°F) for 5 to 10 minutes using an infrared lamp (B).

### CAUTION:

**Do not overheat until plastic wrap is somewhat white.**

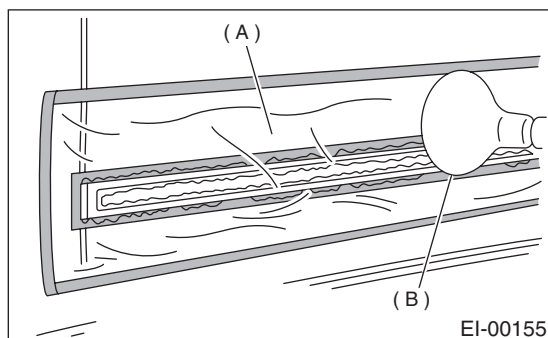

5) Using a plastic spatula, remove traces of two-sided tape from body panel.

6) Remove masking tape and clean traces of two-sided tape using a cloth dampened with white gasoline.

7) Similarly, clean traces of adhesive from two-sided tape on side protector.

### CAUTION:

**Make sure side protector is clean and free of adhesive remover. Clean if necessary.**

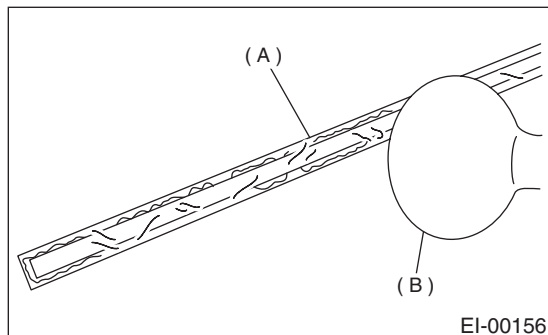

## B: INSTALLATION

1) Apply primer to original side protector (if used), and attach two-sided tape to side protectors as shown.

### Two-sided tape:

**Thickness; 1.2 mm (0.047 in)**

**Width; 5 mm (0.20 in)**

### Recommended primer:

**SUMITOMO 3MK-500 or equivalent**

### Recommended two-sided tape:

**SUMITOMO 3M4210 or equivalent**

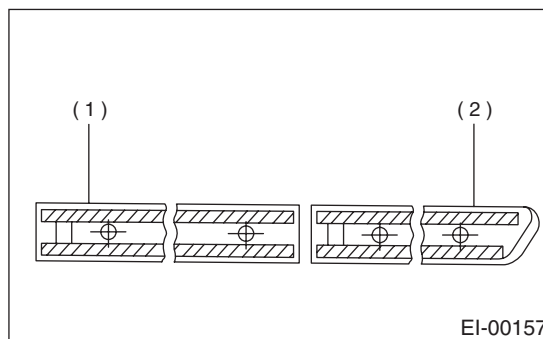

(1) Front door part

(2) Rear door part

2) Using an infrared lamp, heat body panel to 40 to 60°C (104 to 140°F) and rear surface of side protector to 20 to 30°C (68 to 86°F).

3) Remove tack paper from two-sided paper. While aligning clips with holes in body panel, attach two-sided tape to side protector and body panel with a force of more than 49 N (5 kgf, 11 lb) with roller. Do not allow air to enter mating surface of the two.

### CAUTION:

• **To maintain adhesive power, do not wash the vehicle for 24 hours after tape application.**

• **Push clip in securely using hands.**

**(To prevent deformation, do not use excessive force.)**