

16. Rear Window Defogger

A: INSPECTION

CAUTION:

When wiping stain on glass off with cloth, use a dry and soft cloth and move it in the direction of the heat wire extension to avoid damage to the heat wire.

- 1) Turn ignition switch to ON.
- 2) Turn defogger switch to ON.
- 3) Wrap tips of tester pins with aluminum foil to avoid damage to heat wire.

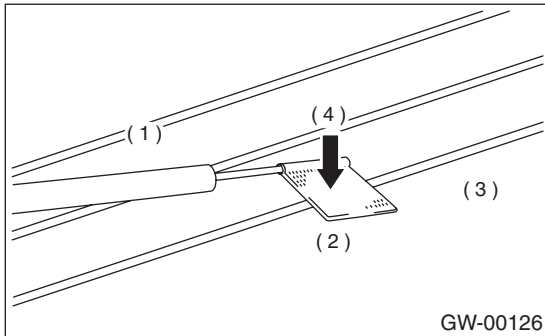

- (1) Tester probe
- (2) Tin foil
- (3) Heat wire
- (4) PRESS

4) Measure voltage at wire center (A) with DC voltmeter.

Standard voltage:
Approx. 6 volts

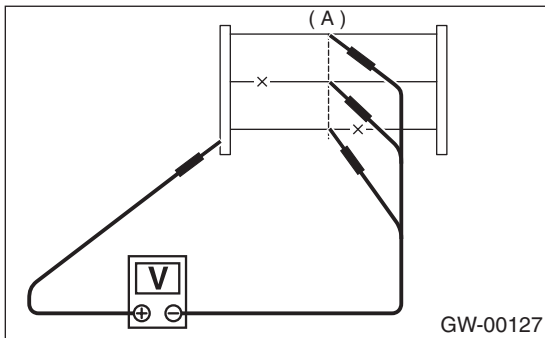

Voltage	Criteria
Approx. 6 V	OK
Approx. 12 V or 0 V	Broken

NOTE:

- If the measured value is 12 volts, heat wire is open between wire center and positive (+) end.
- If zero volt, heat wire is open between wire center and ground.

5) Apply positive lead of voltmeter to positive terminal of voltmeter, and then move negative lead along the wire up to the negative terminal end. If voltage changes from zero to several volts during movement of lead, heat wire is open at the voltage change point.

B: REPAIR

- 1) Clean broken portion with alcohol or white gasoline.
- 2) Mask both side of wire with thin film.
- 3) Apply conductive silver composition (DUPONT No. 4817) to broken portion.

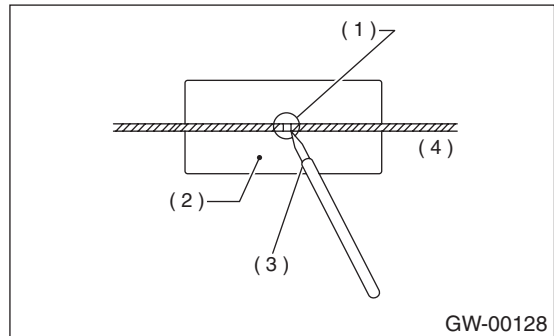

- (1) Broken portion
- (2) Masking thin film
- (3) Conductive silver composition
- (4) Broken wire

4) After repair, check wire.