

6. Front Door Glass

A: REMOVAL

- 1) Remove door trim. <Ref. to EI-32, REMOVAL, Front Door Trim.>
- 2) Remove sealing cover. <Ref. to EB-13, REMOVAL, Front Sealing Cover.>
- 3) Remove outer weatherstrip.
- 4) Remove inner stabilizer.

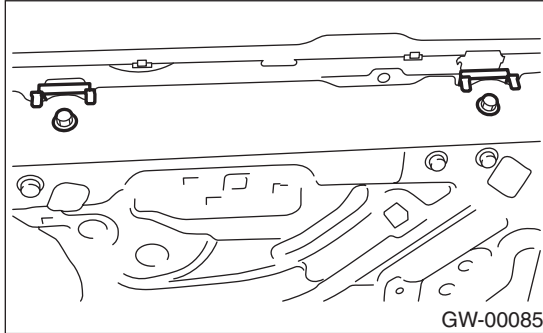

- 5) Remove outer mirror. <Ref. to GW-30, REMOVAL, Outer Mirror Assembly.>
- 6) Remove gusset.

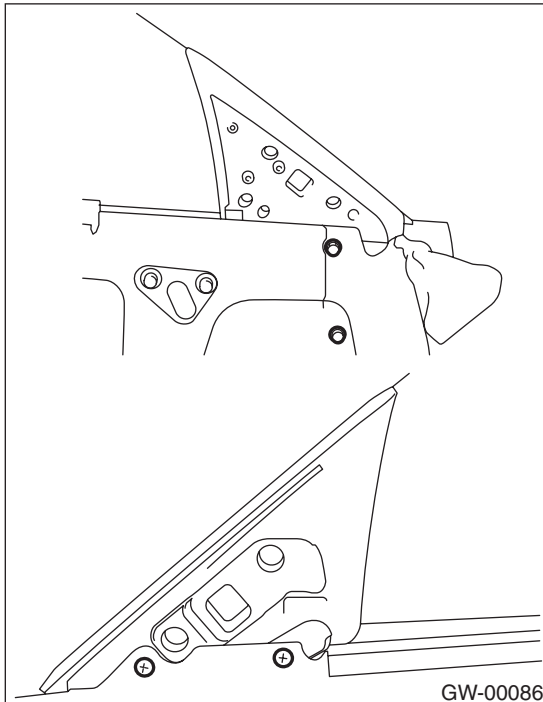

- 7) Operate the power window switch to move glass to the position shown in the figure, and then remove the two nuts from service holes.

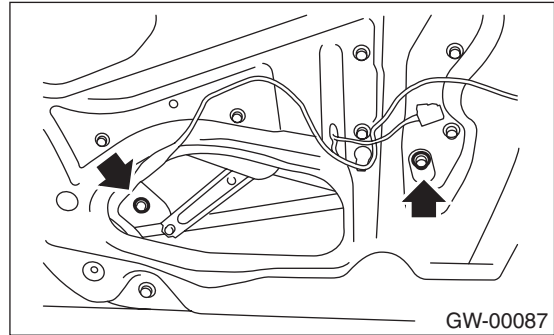

- 8) Take out glass from above of door panel.

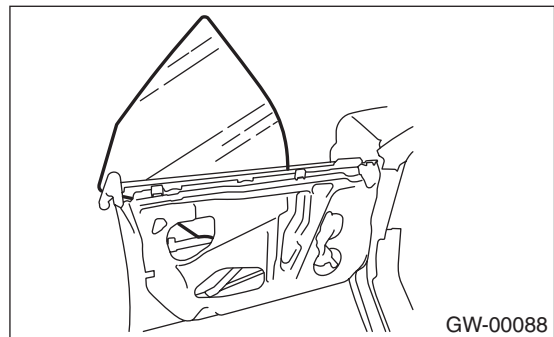

CAUTION:

- Do not turn regulator in the closing direction after removal of the glass. Otherwise gear may be disengaged.
- Avoid impact and damage to the glass.

B: INSTALLATION

- 1) Install in the reverse order of removal.

CAUTION:

Make sure that glass stay is placed securely in sash.

- 2) Adjust front door glass. <Ref. to GW-12, ADJUSTMENT, Front Door Glass.>

Tightening torque:

Refer to **COMPONENT** in *General Description*. <Ref. to EB-4, FRONT DOOR PANEL, COMPONENT, General Description.> and <Ref. to GW-3, FRONT DOOR GLASS, COMPONENT, General Description.>

FRONT DOOR GLASS

GLASS/WINDOWS/MIRRORS

C: ADJUSTMENT

NOTE:

Before adjustment, ensure that all adjusting bolts of stabilizer, upper stopper, and sash are loose and door glass is raised so that it is in contact with weatherstrip.

1) Temporarily tighten one adjusting bolt on one side of rear sash at the midpoint of slotted hole in the inner panel.

2) Temporarily tighten regulator B-channel in a position slightly lower than midpoint of slotted hole.

3) Lower door glass 10 to 15 mm (0.39 to 0.59 in) from fully closed position. While applying outward pressure of 45 ± 5 N (4.59 ± 0.51 kgf, 10.1 ± 1.1 lb) (F) to upper edge of glass above midpoint of two outer stabilizers, press inner stabilizer at 10 ± 5 N (1.02 ± 0.51 kgf, 2.2 ± 1.1 lb) until it just touches the glass, then secure it.

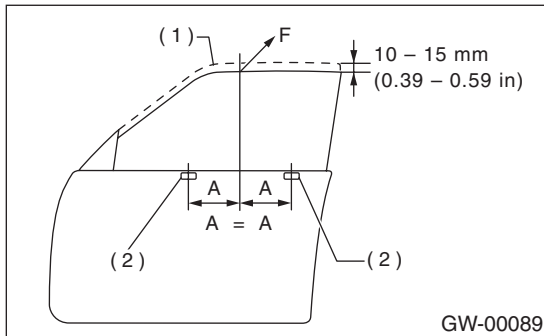

- (1) Full close
- (2) Stabilizer

4) For adjustment of clearance between front and rear glasses, loosen nuts (A), and move glass sash back and forth until clearance becomes the value shown.

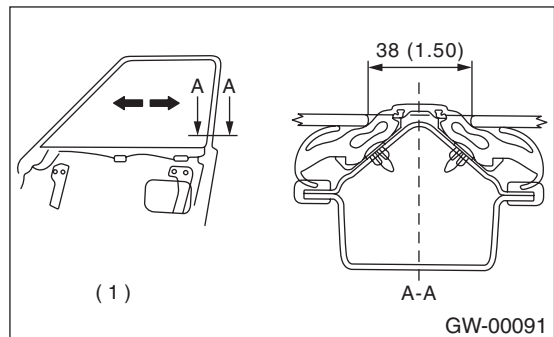
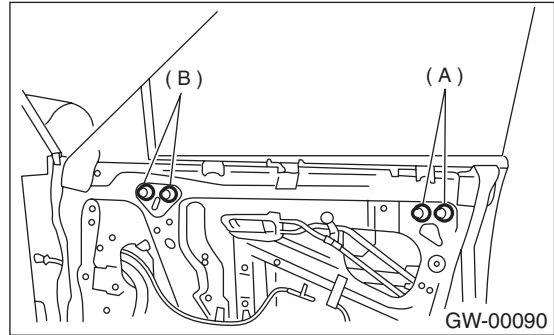

(1) Unit: mm (in)

5) For adjustment of upper and lower ends of center pillar, loosen adjusting nut (A) of B-channel (B).

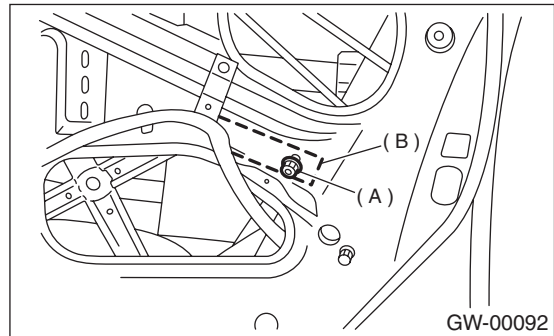

6) Adjust so that upper and lower ends of center pillar are the same size.

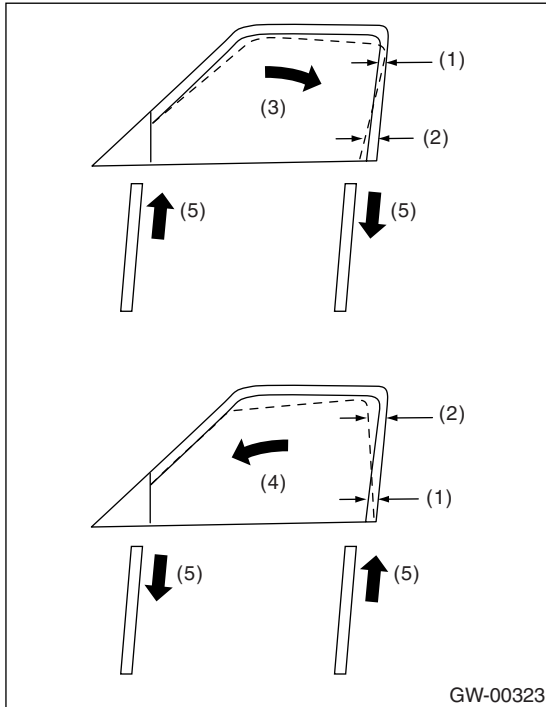

- (1) Narrow
- (2) Wide
- (3) Glass tilts too far rearward
- (4) Glass tilts too far forward
- (5) Stopper adjustment direction

7) After adjusting the clearance between center pillar, up and down the glass several times to check glass contact to stopper when glass is fully closed. Adjust it to contact the front and rear stopper simultaneously.

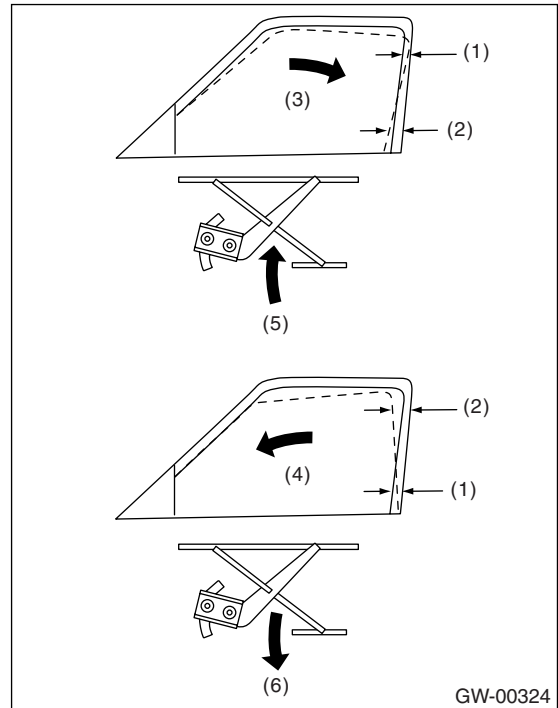

- (1) Narrow
- (2) Wide
- (3) When the stopper of door sash (rear) contacts first
- (4) When the stopper of door sash (front) contacts first
- (5) Raise B channel
- (6) Lower B channel

FRONT DOOR GLASS

GLASS/WINDOWS/MIRRORS

8) For glass stroke adjustment, install ST to glass, close door, raise glass until positional relationship between glass and weatherstrip becomes the value shown in the figure. And secure the glass so that the upper stopper correctly touches the glass holder.

ST 61299AE000 SPACER [Glass thickness: 5 mm (0.197 in) for front door glass]

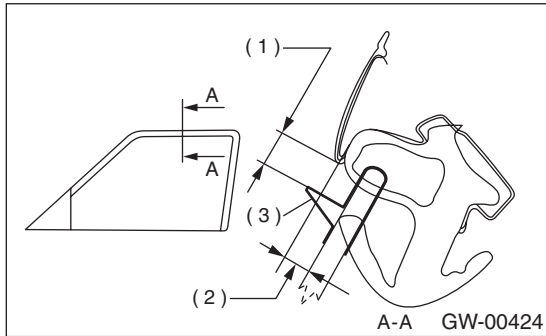

- (1) 3.2 - 4.8 mm (0.126 - 0.189 in)
- (2) 6 mm (0.24 in)
- (3) ST

9) After stabilizer adjustment, carry out degree of adhesion adjustment. First, visually ensure positional relationship between retainer & molding and glass of the roof side, and then begin with rear sash adjustment. Install the ST to glass and adjust two adjusting bolts alternately step by step to obtain dimensions shown below (cross-section A).

NOTE:

If two nuts are loosened at the same time, sash moves back and forth. Therefore, when one nut is adjusted, secure the other.

10) Make the same adjustment of two adjusting bolts of rear sash.

ST 61299AE000 SPACER [Glass thickness: 5 mm (0.197 in) for front door glass]

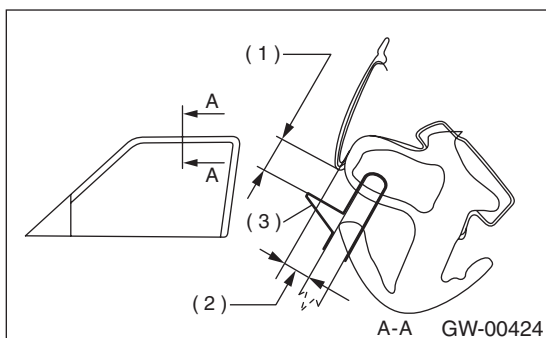

- (1) 3.2 - 4.8 mm (0.126 - 0.189 in)
- (2) 6 mm (0.24 in)
- (3) ST

CAUTION:

Do not tilt sash bracket to inner panel during adjustment. Otherwise smooth regulator operation cannot be achieved.

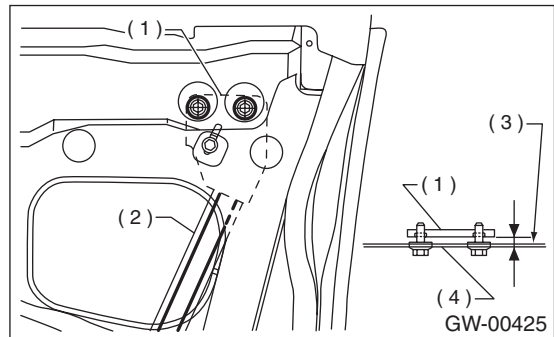

- (1) Sash bracket
- (2) Rear sash
- (3) Adjust a line parallel
- (4) Inner panel

11) Make adjustment of front sash in the same manner as that of rear sash.

NOTE:

Although front and rear sashes must, as a rule, be adjusted in the same manner, in some door installation, the adjustment in a different manner may be required. However, adjustment of one sash to the maximum amount and the other to the minimum amount is not permitted. Such adjustment may result in application of excessive load to regulator.

12) After adjustments, tighten nuts.

13) After adjustment of glass, if there is a gap between outer lip of gusset and glass surface, adjust the gap with adjusting bolt (A) in lower fitting part of gusset to prevent generation of wind noise.

14) During adjustments, loosen other three clamping bolts.

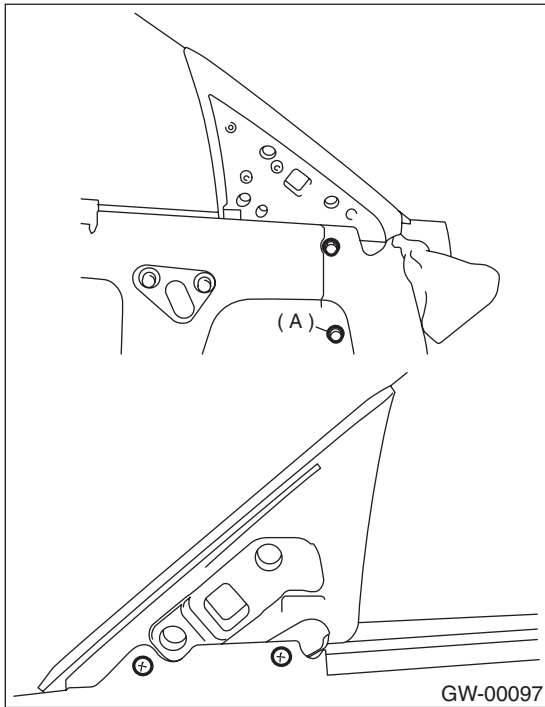

15) After adjustment, tighten bolts and nuts.