

10. Headlight Bulb

A: REMOVAL

CAUTION:

- Because the halogen bulb operates at a high temperature, dirt and oil on the bulb surface reduces the bulb's service life. Hold the flange portion when replacing the bulb. Never touch the glass portion.
- Do not leave the headlight without a bulb for a long time. Dust, moisture, etc. entering the headlight may affect its the performance.

1. SINGLE-BULB TYPE

- 1) Disconnect ground cable from battery.
- 2) Remove duct (A) (when right side headlight is removed).

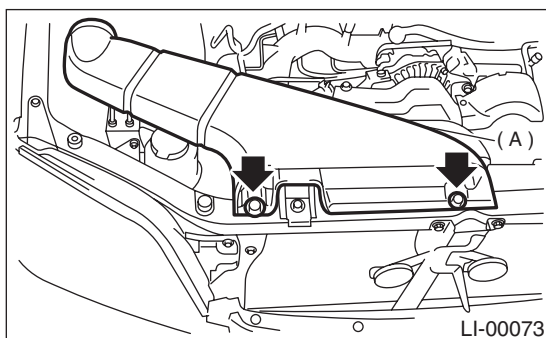

- 3) Disconnect harness connector.
- 4) Remove rubber cover.
- 5) Push to remove spring retainer, and then detach the headlight bulb.

2. DUAL-BULB TYPE

- 1) Disconnect ground cable from battery.
- 2) Remove duct (A) (when right side headlight is removed).

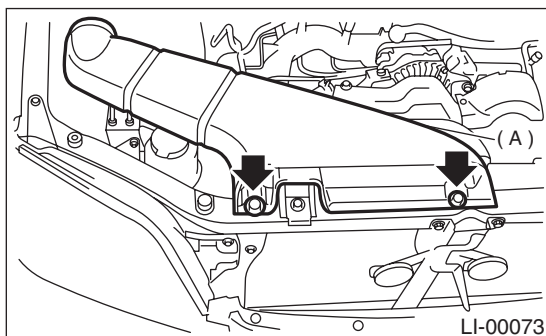

- 3) Remove back cover (A).

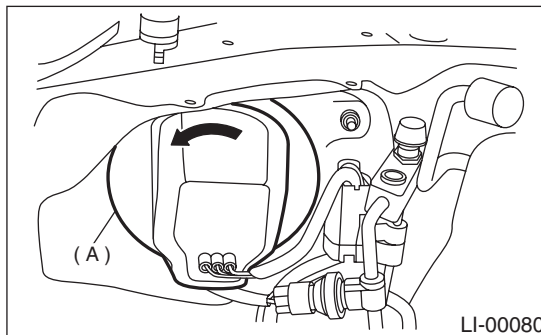

- 4) Disconnect harness connector.
- 5) Push to remove spring retainer (A) (low beam) or turn bulb assembly (B) counterclockwise (high beam), and then detach headlight bulb.

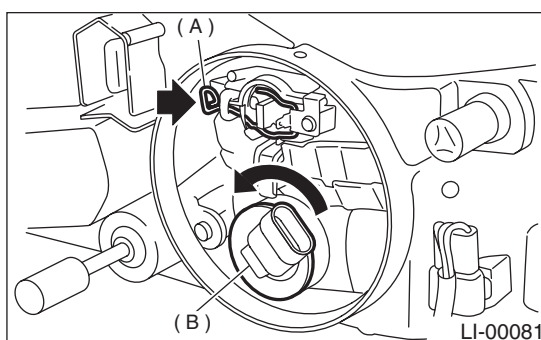

B: INSTALLATION

Install in the reverse order of removal.

C: INSPECTION

- 1) Visually check the bulb for blow out.
- 2) Check the bulb specification. <Ref. to LI-2, SPECIFICATIONS, General Description.>
- 3) If NG, replace the bulb with a new one.