

In case of emergency

<i>Hazard warning flasher</i>	8-2
<i>Engine overheating</i>	8-2
<i>If steam is coming from the engine compartment</i>	8-2
<i>If no steam is coming from the engine compartment</i>	8-3
<i>Jump starting</i>	8-3
<i>How to jump start</i>	8-4
<i>Flat tires</i>	8-6
<i>Changing a flat tire</i>	8-6
<i>Tire changing tools</i>	8-10
<i>Towing</i>	8-12
<i>Transporting your vehicle using a flat-bed truck</i>	8-12
<i>Towing with the front wheels raised off the ground</i> <i>for AT vehicles only</i>	8-12
<i>Towing with all wheels on the ground</i>	8-13
<i>Towing eyelet</i>	8-15

Hazard warning flasher

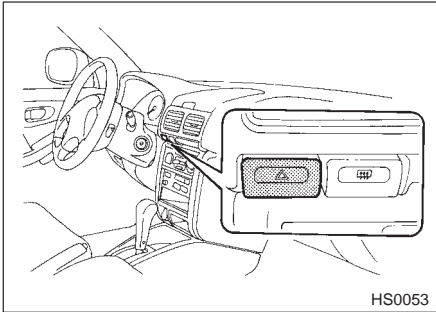

Day or night, if your vehicle becomes a traffic hazard, use the hazard warning flasher. Avoid stopping on the road. It is best to safely pull off the road if a problem occurs. The hazard warning flasher can be activated regardless of the ignition switch position.

Turn on the hazard warning by pushing the hazard warning flasher switch. Turn it off by pushing the switch again.

Engine overheating



WARNING

Never attempt to remove the radiator cap until the engine has been shut off and has fully cooled down. When the engine is hot, the coolant is under pressure. Removing the cap while the engine is still hot could release a spray of boiling hot coolant, which could burn you very seriously.

If the engine overheats, safely pull off the road and stop the vehicle in a safe place.

■ If steam is coming from the engine compartment

Turn the engine off and get everyone away from the vehicle until it cools down.

■ **If no steam is coming from the engine compartment**

1. Keep the engine running at idling speed.
2. Open the hood to ventilate the engine compartment.
Confirm that the cooling fan is turning. If the fan is not turning, immediately turn the engine off and contact your authorized dealer for repair.
3. After the engine coolant temperature has dropped, turn off the engine.

If the temperature gauge stays at the overheated zone, turn the engine off.

4. After the engine has fully cooled down, check the coolant level in the reserve tank.

If the coolant level is below the "MIN" mark, add coolant up to the "MAX" mark.

5. If there is no coolant in the reserve tank, add coolant to the reserve tank. Then remove the radiator cap and fill the radiator with coolant.

If you remove the radiator cap from a hot radiator, first wrap a thick cloth around the radiator cap, then turn the cap counterclockwise slowly without pressing down until it stops. Release the pressure from the radiator. After the pressure has been fully released, remove the cap by pressing down and turning it.

Jump starting



WARNING

- **Battery fluid is SULFURIC ACID. Do not let it come in contact with the eyes, skin, clothing or the vehicle.**

If battery fluid gets on you, thoroughly flush the exposed area with water immediately. Get medical help if the fluid has entered your eyes.

If battery fluid is accidentally swallowed, immediately drink a large amount of milk or water, and obtain immediate medical help.

Keep everyone including children away from the battery.

-
- The gas generated by a battery explodes if a flame or spark is brought near it. Do not smoke or light a match while jump starting.
 - Never attempt jump starting if the discharged battery is frozen. It could cause the battery to burst or explode.
 - Whenever working on or around a battery, always wear suitable eye protectors, and remove metal objects such as rings, bands or other metal jewelry.
 - Be sure the jumper cables and clamps on them do not have loose or missing insulation.
- Do not jump start unless cables in suitable condition are available.
- A running engine can be dangerous. Keep your fingers, hands, clothing, hair and tools away from the cooling fan, belts and any other moving engine parts. Removing rings, watches and ties is advisable.

When your vehicle does not start due to a run down (discharged) battery, the vehicle may be jump started by connecting your battery to another battery (called the booster battery) with jumper cables.

Jump starting is dangerous if it done incorrectly. If you are unsure about the proper procedure for jump starting, consult a competent mechanic.

■ How to jump start

1. Make sure the booster battery is 12 volts and the negative terminal is grounded.
2. If the booster battery is in another vehicle, do not let the two vehicles touch.
3. Turn off all unnecessary lights and accessories.
4. Connect the jumper cables exactly in the sequence illustrated.

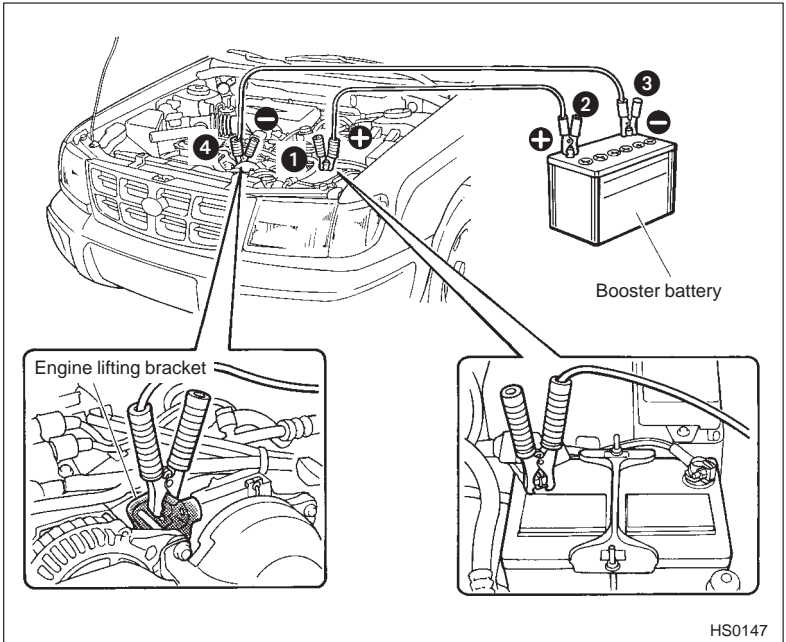

- ① Connect one jumper cable to the positive (+) terminal on the discharged battery.
- ② Connect the other end of the jumper cable to the positive (+) terminal of the booster battery.
- ③ Connect one end of the other cable to the negative (-) terminal of the booster battery.
- ④ Connect the other end of the cable to the engine lifting bracket.

Make sure that the cables are not near any moving parts and that the cable clamps are not in contact with any other metal.

5. Start the engine of the vehicle with the booster battery and run it at moderate speed. Then start the engine of the vehicle that has the discharged battery.
6. When finished, carefully disconnect the cables in exactly the reverse order.

Flat tires



WARNING

- Do not jack up the vehicle on an incline or a loose road surface. The jack can come out of the jacking point or sink into the ground and this can result in a severe accident.
- Use only the jack provided with your vehicle. The jack supplied with the vehicle is designed only for changing a tire. Never get under the vehicle while supporting the vehicle with this jack.
- Always turn the engine off before raising the flat tire off the ground using the jack. Never swing or push the vehicle supported with the jack. The jack can come out of the jacking point due to a jolt and this can result in a severe accident.

If you have a flat tire while driving, never brake suddenly; keep driving straight ahead while gradually reducing speed. Then slowly pull off the road to a safe place.

■ Changing a flat tire



WARNING

- Do not use oil or grease on the wheel studs or nuts when the spare tire is installed. This could cause the nuts to become loose and lead to an accident.
- Never place a tire or tire changing tools in the passenger compartment after changing wheels. In a sudden stop or collisions, loose equipment could strike occupants and cause injury. Store the tire and all tools in the proper place.

1. Park on a hard, level surface, whenever possible, then stop the engine.
2. Set the parking brake securely and shift a manual transmission vehicle in reverse or an automatic transmission vehicle in the "P" (Park) position.
3. Turn on the hazard warning flasher and have everyone get out of the vehicle.

- Put wheel blocks at the front and rear of the tire diagonally opposite the flat tire.

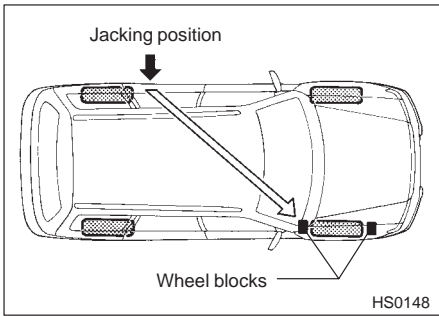

- Take out the spare tire, jack, and wheel nut wrench. See Tire Changing Tools in this chapter.
- Loosen the wheel nuts using the wheel nut wrench but do not remove the nuts.

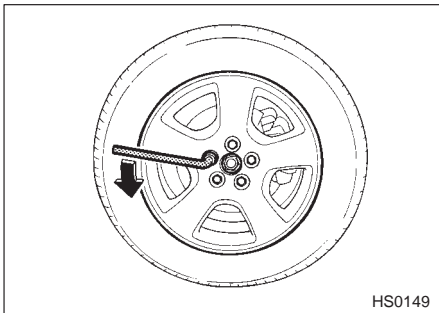

- Place the jack under the side sill at the front or rear jack-up point closest to the flat tire.
Turn the jackscrew by hand until the jack head engages firmly into the jack-up point.

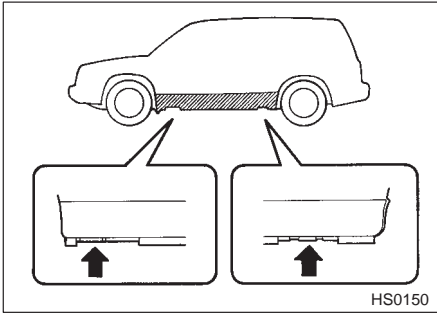

8. Insert the jack handle into the jackscrew, and turn the handle clockwise until the tire clears the ground. Do not raise the vehicle higher than necessary.

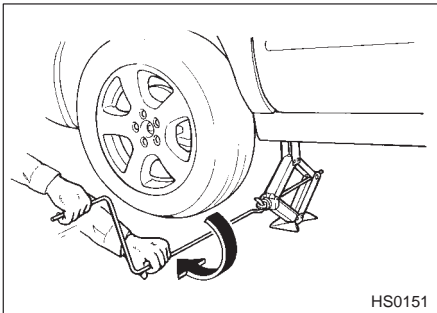

9. Remove the wheel nuts and the flat tire.

10. Before putting the spare tire on, clean the mounting surface of the wheel and hub with a cloth.

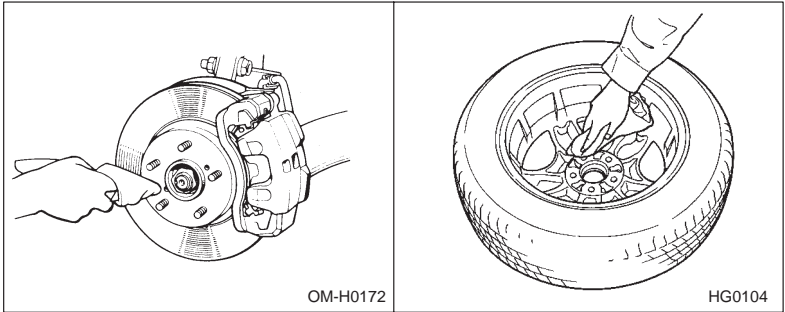

11. Put on the spare tire. Replace the wheel nuts. Tighten them by hand.
12. Turn the jack handle counterclockwise to lower the vehicle.
13. Use the wheel nut wrench to securely tighten the wheel nuts to the specified torque, following the tightening order in the illustration.

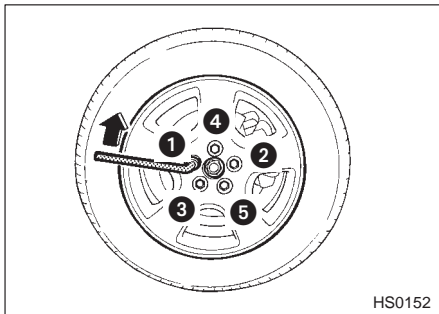

The torque for tightening the nuts is 58 to 72 ft-lb (78 to 98 N-m, 8 to 10 kg-m). This torque is equivalent to applying about 88 to 110 lbs (40 to 50 kg) at the top of the wheel nut wrench. Never use your foot on the wheel nut wrench or a pipe extension on the wrench because you may exceed the specified torque. Have the wheel nut torque checked at a nearest automotive service facility.

14. Store the flat tire in the spare tire compartment.

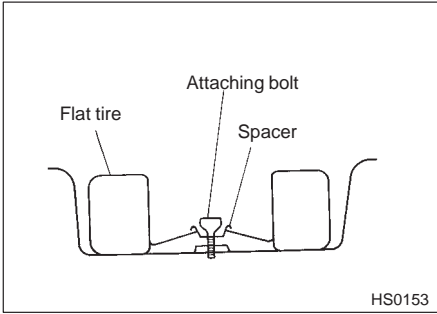

Also store the jack and wheel nut wrench in their storage locations. See Tire Changing Tools in this section.

■ Tire changing tools

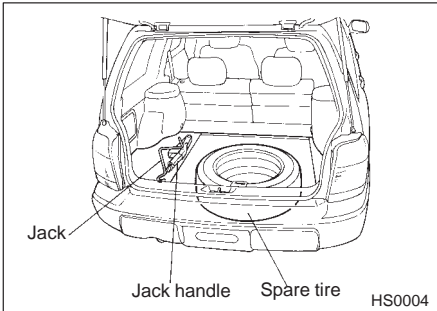

▼ Spare tire

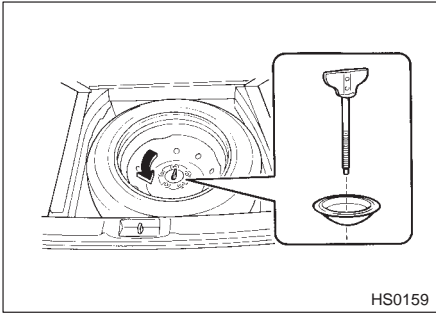

The spare tire is stored under the floor of the luggage compartment. To remove the spare tire, first open the spare tire cover and remove the storage tray, turn the attaching bolt counterclockwise, then take the spare tire out.

▼ Jack and jack handle

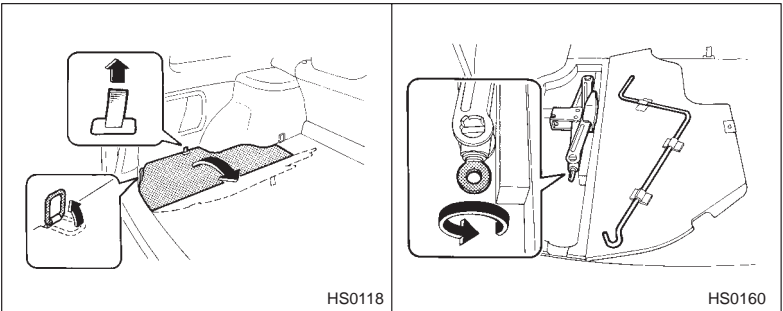

The jack is stored under the left side of the luggage floor.

To take out the jack:

First raise the cargo anchorage eyelet on the rear-left side of the luggage compartment and pull the tab to open the lid, turn the jack screw counterclockwise to loosen it, then remove the jack.

The jack handle is stored under the lid.

Towing

If towing is necessary, it is best done by your SUBARU dealer or a commercial towing service. Observe the following procedures for safety.

■ Transporting your vehicle using a flat-bed truck

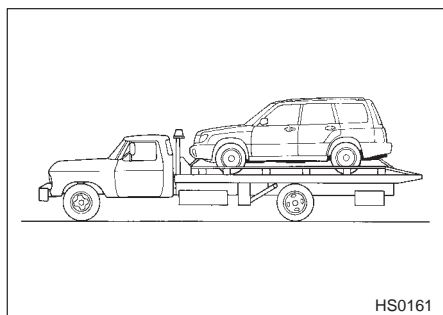

This is the best way to transport your vehicle. Use the following procedures to ensure safe transportation.

1. Shift the selector lever into the "P" position for automatic transmission vehicles or "1st" for manual transmission vehicles.
2. Pull up the parking brake lever firmly.
3. Secure the vehicle onto the carrier properly with safety chains. Each of safety chain should be equally tightened and care must be taken not to pull the chains so tightly that the suspension bottoms out.

■ Towing with the front wheels raised off the ground (for AT vehicles only)



WARNING

Never tow manual transmission AWD vehicles with the front wheels raised off the ground while the rear wheels are on the ground. This will cause the vehicle to spin away due to the operation or deterioration of the viscous coupling.



CAUTION

When transmission failure occurs, transport your vehicle on a flat-bed truck.

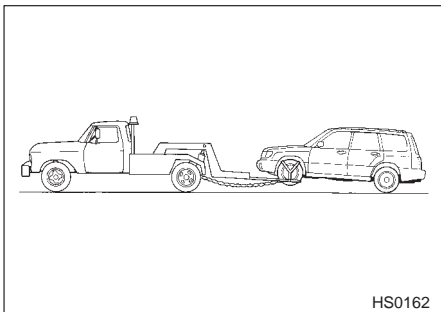

1. Check the transmission and differential oil levels and add oil to bring it to the upper level if necessary.
2. Release the parking brake and put the transmission in neutral.
3. The ignition switch should be in the "ACC" position while the vehicle is being towed.
4. Take up slack in the towline slowly to prevent damage to the vehicle.

■ Towing with all wheels on the ground



WARNING

- **Never turn the ignition switch to the "LOCK" position while the vehicle is being towed because the steering wheel and the direction of the wheels will be locked.**
- **Remember that the brake booster and power steering do not function when the engine is not running. Because the engine is turned off, it will take greater effort to operate the brake pedal and steering wheel.**

⚠ CAUTION

- When transmission failure occurs, transport your vehicle on a flat-bed truck.
- For AWD vehicles, the traveling speed must be limited to less than 20 mph (30 km/h) and the traveling distance to less than 31 miles (50 km). For greater speeds and distances, transport your vehicle on a flat-bed truck.

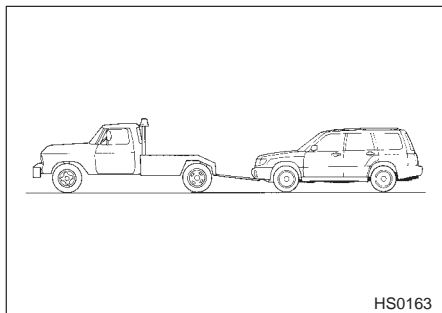

We do not recommend this method of towing. Use this method only when towing service by a SUBARU dealer or a commercial towing service is not available.

1. Check the transmission and differential oil levels and add oil to bring it to the upper level if necessary.
2. Release the parking brake and put the transmission in neutral.
3. The ignition switch should be in the "ACC" position while the vehicle is being towed.
4. Take up slack in the towline slowly to prevent damage to the vehicle.

■ Towing eyelet

⚠ CAUTION

- Never use the tie-down eyelet closest to the muffler under the vehicle for towing purposes.
- Do not apply excessive lateral load to the towing eyelets.

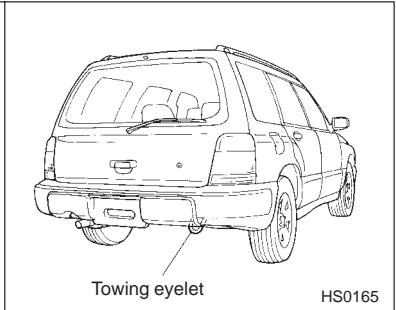
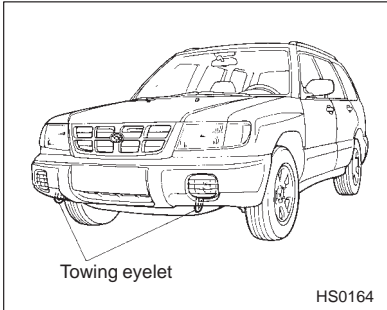

⚠ Never use tie-down eyelet for towing purpose.

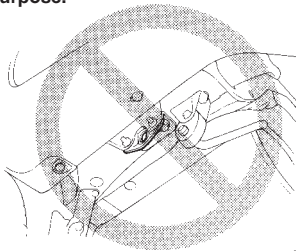

The towing eyelets should be used only in an emergency (e.g., to free a stuck vehicle from mud, sand or snow).