

E: INSTALLATION

Installation is in the reverse order of removal. Observe the following:

- 1) Apply fluid packing to matching surfaces of oil pump.

Fluid packing:

THREE BOND 1215 or equivalent

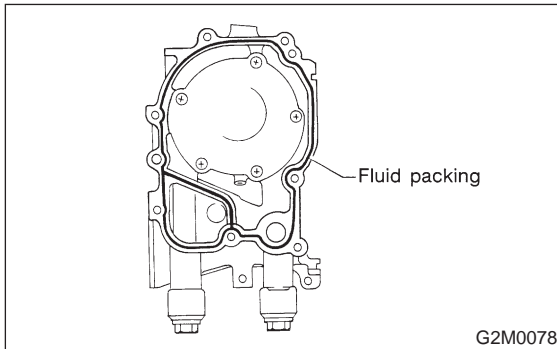

- 2) Replace O-ring with a new one.
- 3) Apply a coat of engine oil to the inside of the oil seal.

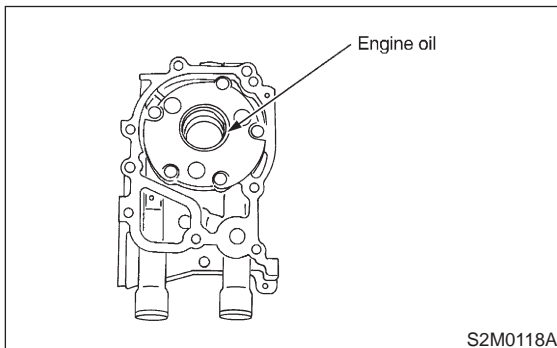

- 4) Be careful not to scratch oil seal when installing oil pump on cylinder block.
- 5) Position the oil pump, aligning the notched area with the crankshaft, and push the oil pump straight.

CAUTION:

Make sure the oil seal lip is not folded.

- 6) Install oil pump.

Tightening torque:

6.4 N·m (0.65 kg·m, 4.7 ft·lb)

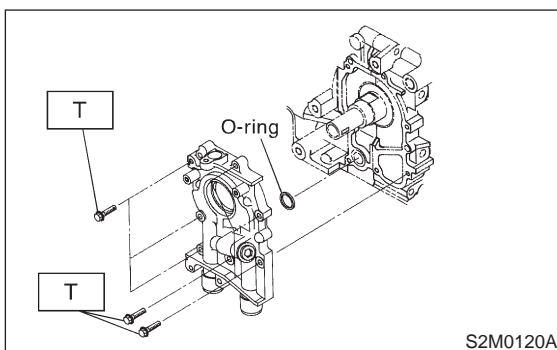

2. Oil Pan and Oil Strainer

A: REMOVAL

- 1) Disconnect battery ground cable.

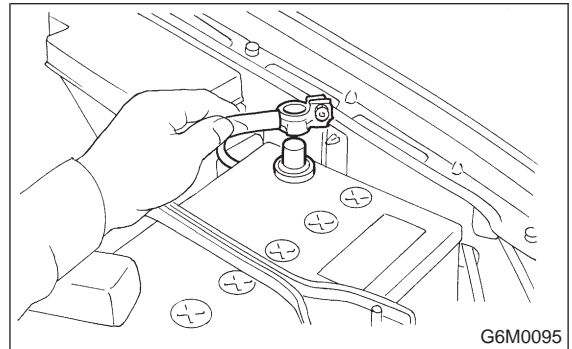

- 2) Remove front wheels.
- 3) Remove air intake duct and air intake chamber.

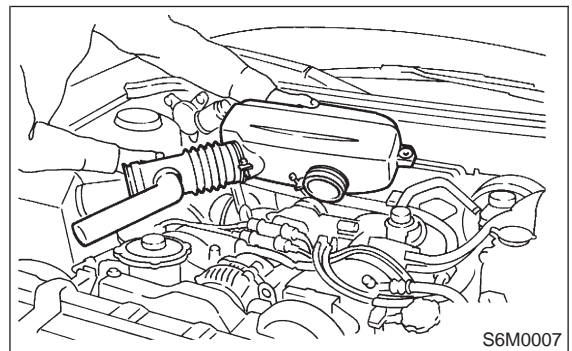

- 4) Disconnect front oxygen sensor connector.

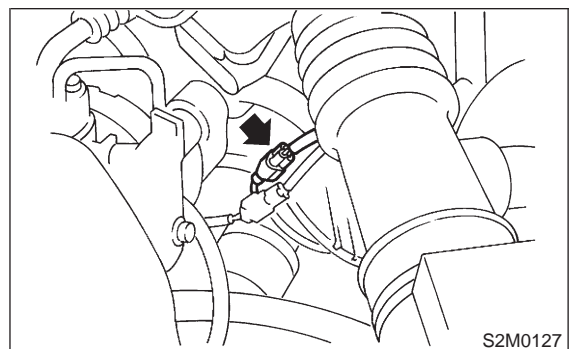

- 5) Disconnect rear oxygen sensor connector. (California spec. vehicles)

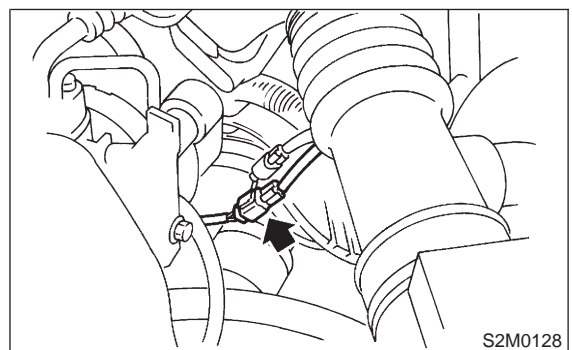

6) Remove pitching stopper.

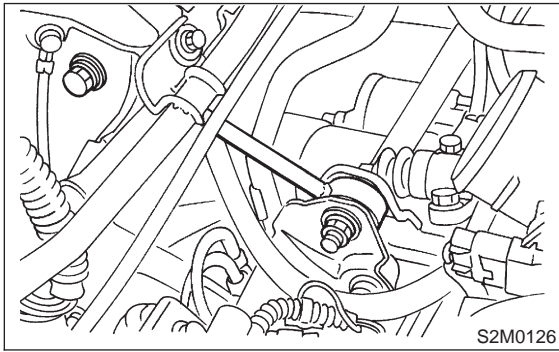

7) Remove radiator upper bracket.

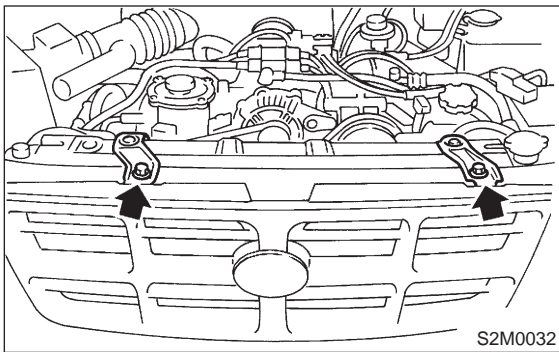

8) Support engine with a lifting device and wire ropes.

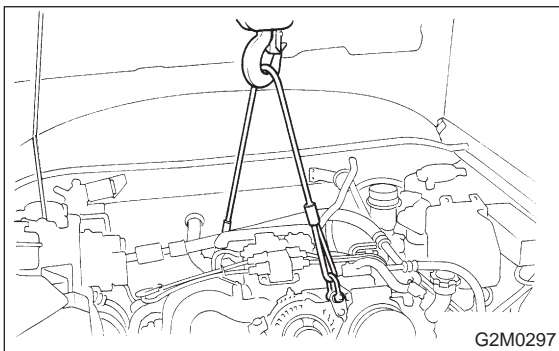

9) Lift-up the vehicle.

CAUTION:
At this time, raise up wire ropes.

10) Remove under cover.

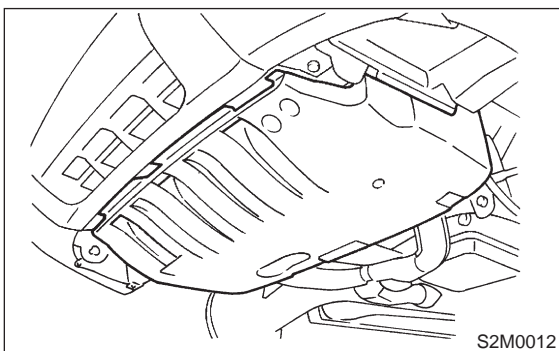

11) Drain engine oil.

Set container under the vehicle, and remove drain plug from oil pan.

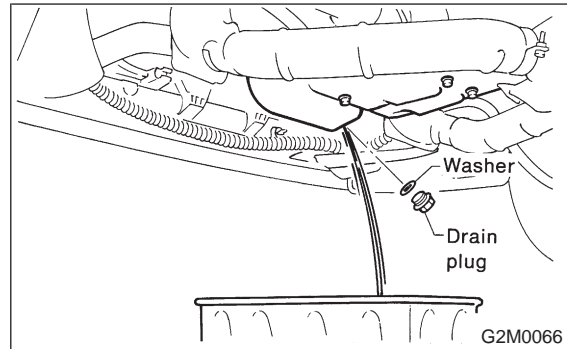

12) Disconnect connector from rear oxygen sensor. (Except California spec. vehicles)

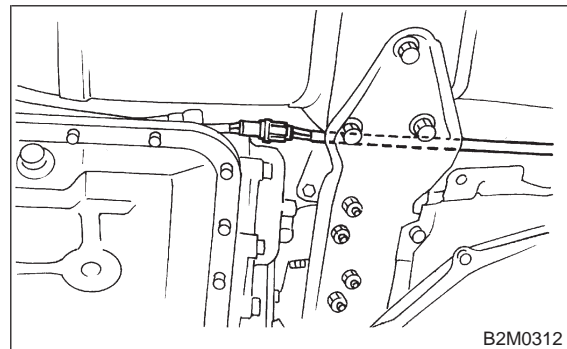

13) Remove front exhaust pipe.

(1) Separate front catalytic converter from center exhaust pipe.

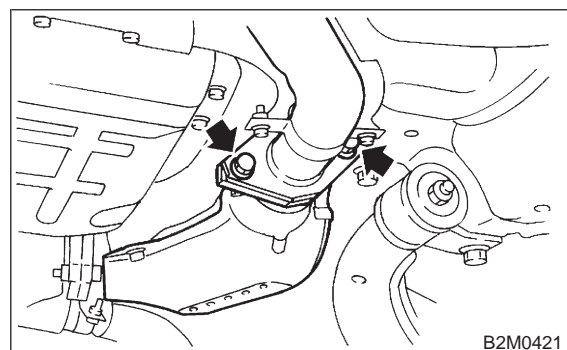

(2) Remove front exhaust pipe from engine.

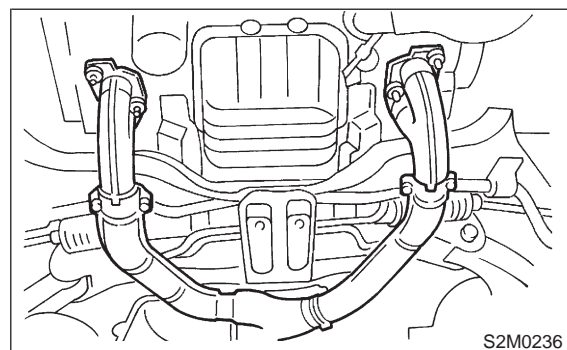

2. Oil Pan and Oil Strainer

(3) Remove bolt which installs front exhaust pipe on bracket.

14) Remove nuts which install front cushion rubber onto front crossmember.

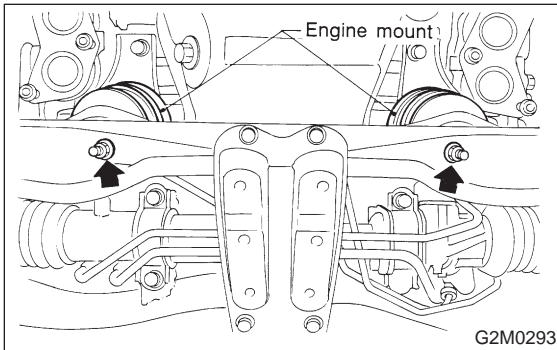

15) Remove bolts which install oil pan on cylinder block while raising up engine.

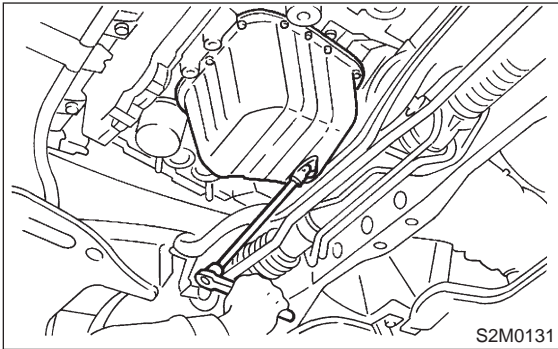

16) Insert oil pan cutter blade between cylinder block-to-oil pan clearance.

CAUTION:

Do not use a screwdriver or similar tool in place of oil pan cutter.

17) Remove oil strainer.

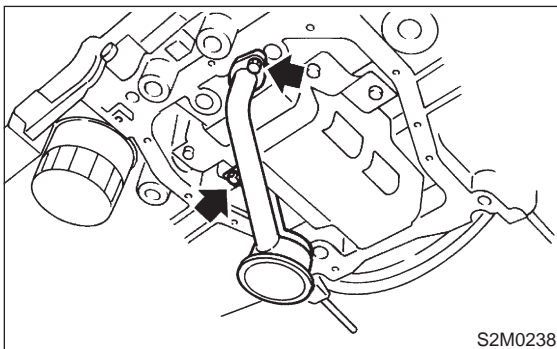

18) Remove baffle plate.

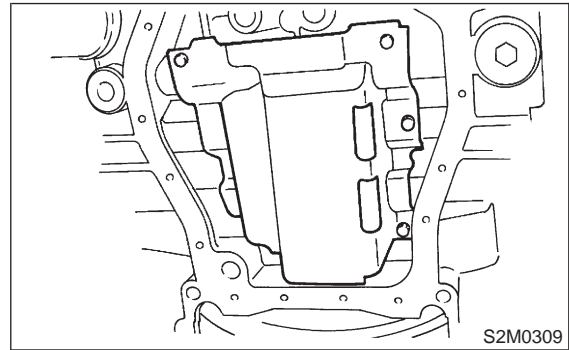
**B: INSPECTION**

By visual check make sure oil pan, oil strainer and baffle plate are not damaged.

C: INSTALLATION**CAUTION:**

Before installing oil pan, clean sealant from oil pan and engine block.

1) Install baffle plate.

Tightening torque:

6.4 N-m (0.65 kg-m, 4.7 ft-lb)

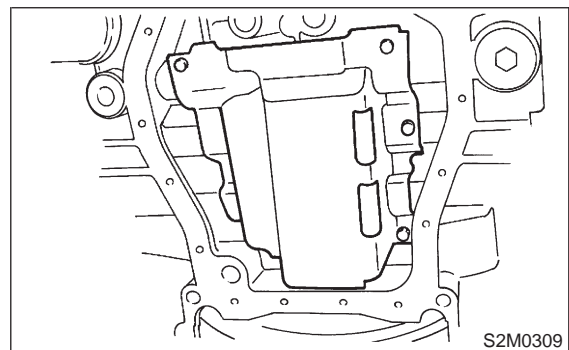

2) Install oil strainer onto baffle plate.

CAUTION:

Replace O-ring with a new one.

Tightening torque:

10 N-m (1.0 kg-m, 7 ft-lb)

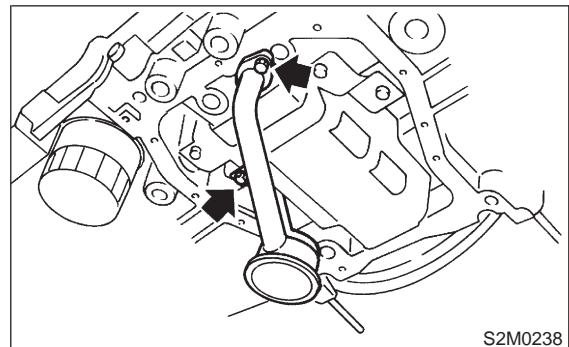

3) Apply fluid packing to mating surfaces and install oil pan.

Fluid packing:

THREE BOND 1215 or equivalent

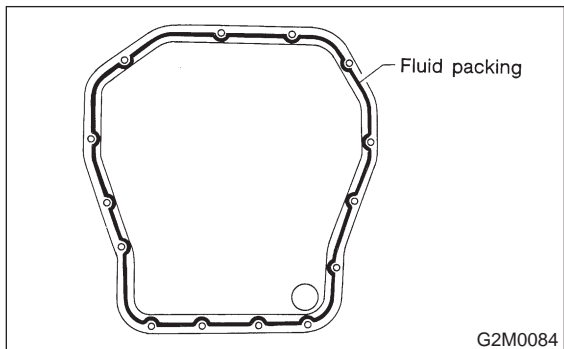

4) Tighten bolts which install oil pan onto engine block.

Tightening torque:

5 N-m (0.5 kg-m, 3.6 ft-lb)

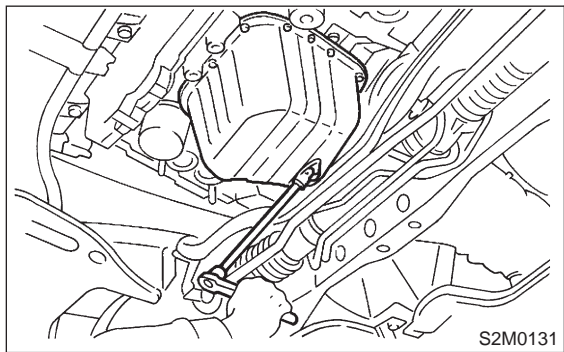

5) Lower engine onto front crossmember.
6) Tighten nuts which install front cushion rubber onto front crossmember.

Tightening torque:

69±15 N-m (7.0±1.5 kg-m, 51±11 ft-lb)

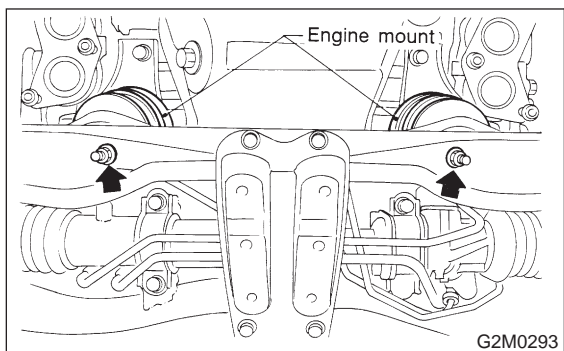

7) Install front exhaust pipe.

CAUTION:

Always use the new gaskets.

- (1) Place front exhaust pipe on bracket.
- (2) Tighten nuts which install front exhaust pipe on engine.

Tightening torque:

30±5 N-m (3.1±0.5 kg-m, 22.4±3.6 ft-lb)

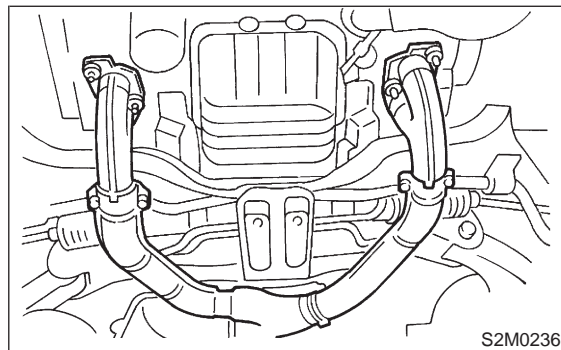

(3) Tighten nuts which install front catalytic converter to center exhaust pipe.

Tightening torque:

35±5 N-m (3.6±0.5 kg-m, 26.0±3.6 ft-lb)

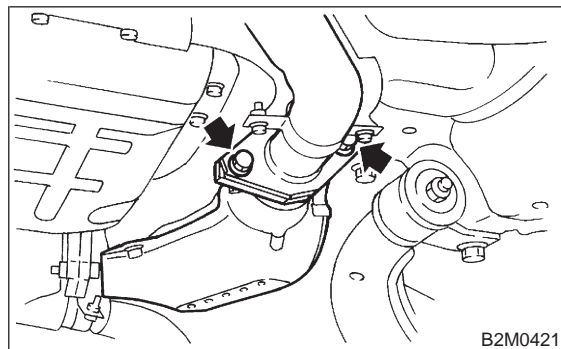

(4) Tighten bolt which installs front exhaust pipe on bracket.

Tightening torque:

24±3 N-m (2.4±0.3 kg-m, 17.4±2.2 ft-lb)

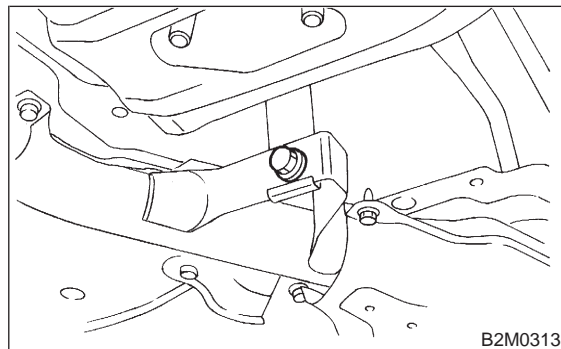

8) Connect connector to rear oxygen sensor.
(Except California spec. vehicles)

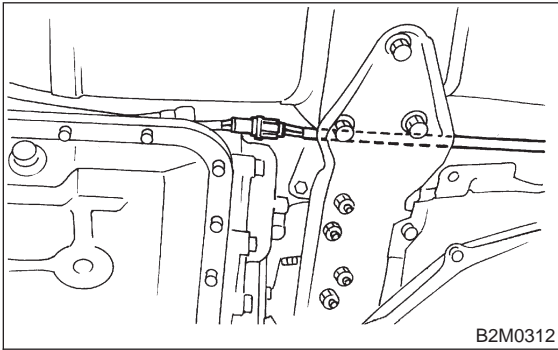

9) Install under cover.

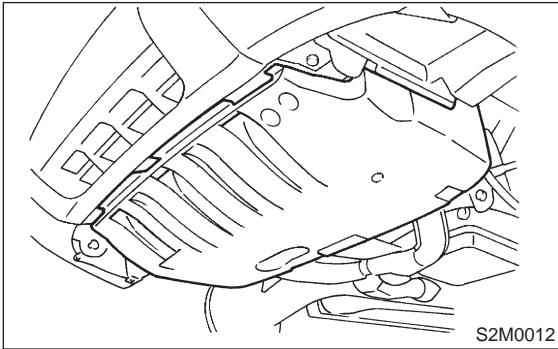

10) Lower the vehicle.

CAUTION:
At this time, lower lifting device and release steel cables.

11) Remove lifting device and steel cables.

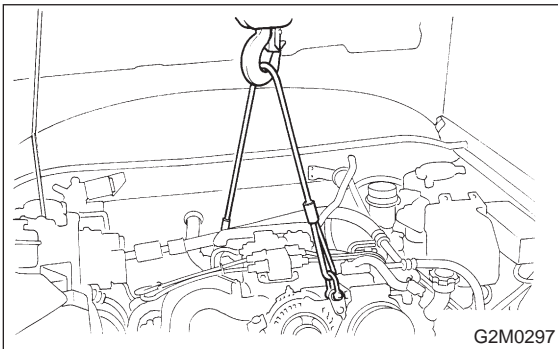

12) Connect connector to front oxygen sensor.

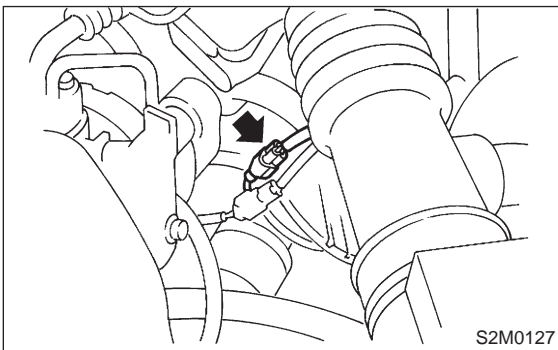

13) Connect connector to rear oxygen sensor.
(California spec. vehicles)

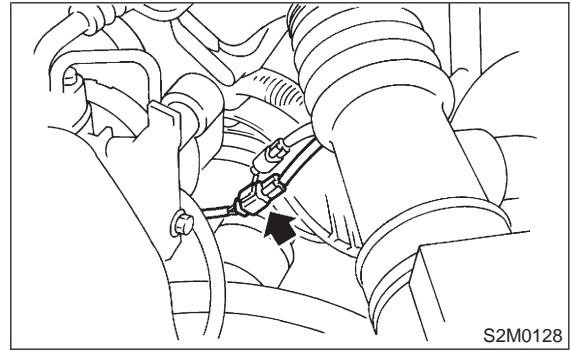

14) Install pitching stopper.

Tightening torque:

T1: 49±5 N·m (5.0±0.5 kg·m, 36.2±3.6 ft·lb)

T2: 57±10 N·m (5.8±1.0 kg·m, 42±7 ft·lb)

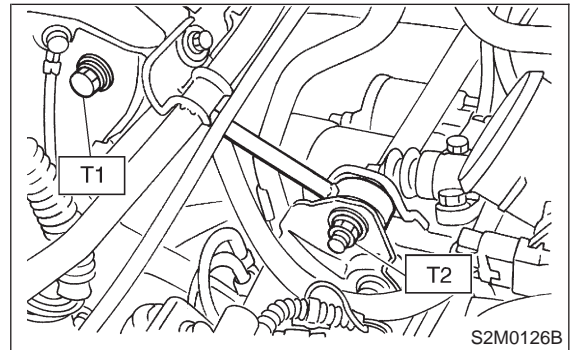

15) Install radiator upper brackets.

Tightening torque:

18±5 N·m (1.8±0.5 kg·m, 13±4 ft·lb)

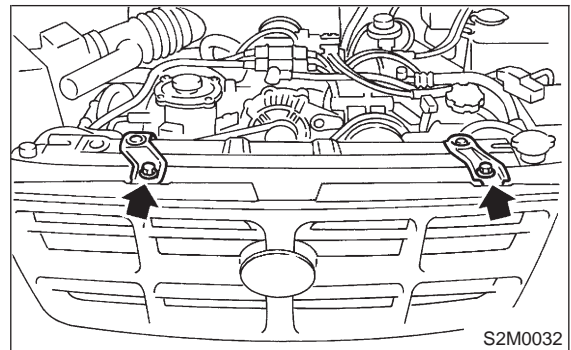

16) Install air intake duct and air intake chamber.

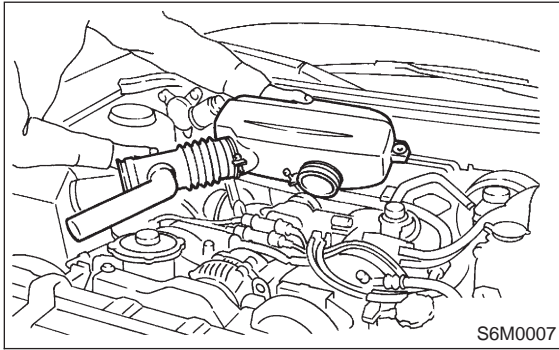

3. Oil Pressure Switch

A: REMOVAL

- 1) Remove alternator from bracket.
 - (1) Disconnect connector and terminal from generator.

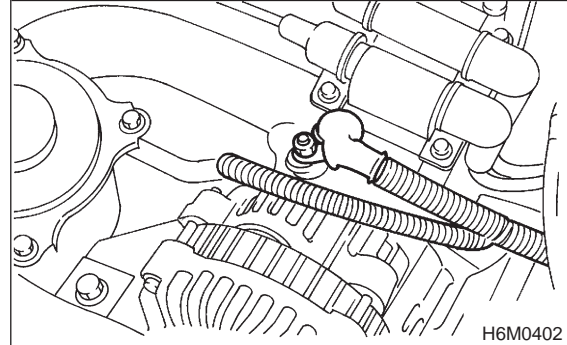

- (2) Remove V-belt cover.

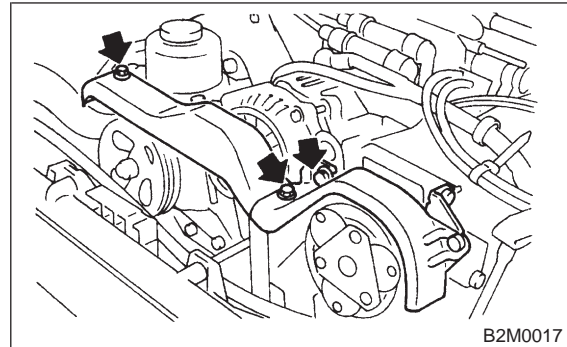

- (3) Loosen lock bolt and slider bolt, and remove front side V-belt.
- (4) Remove bolts which install generator on bracket.

