

## 8. Main Fuel Level Sensor

### A: REMOVAL

- 1) Release fuel pressure. <Ref. to 2-8 [W1A0].>
- 2) Open fuel flap lid, and remove fuel filler cap.

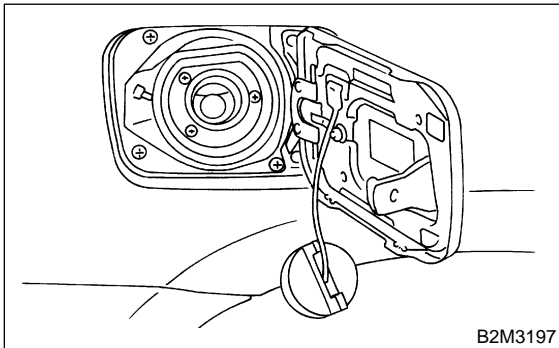

- 3) Disconnect battery ground cable.

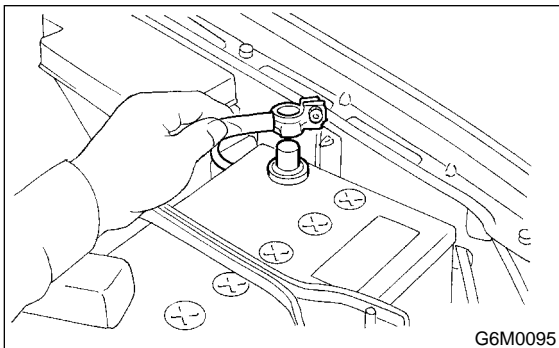

- 4) Remove the floor box located just behind the rear seat.
- 5) Remove service hole cover.

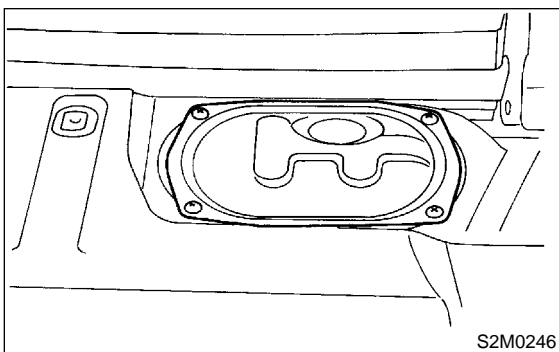

- 6) Disconnect connector from fuel pump.

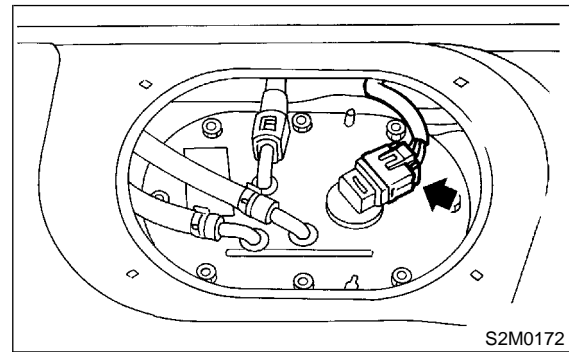

- 7) Move clips, and then disconnect fuel delivery hose (A), return hose (B) and jet pump hose (C).
- 8) Disconnect quick connector, and then disconnect fuel delivery hose (A). <Ref. to 2-8 [W7A0].>

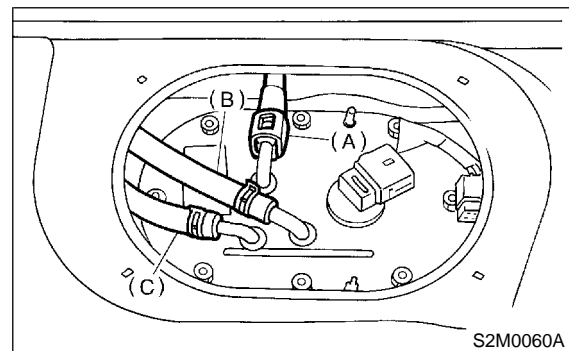

- 9) Remove nuts which install fuel pump assembly onto fuel tank.

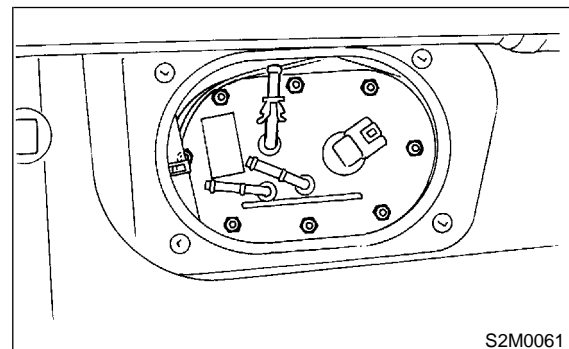

- 10) Take off fuel pump assembly from fuel tank.
- 11) Disconnect connector from fuel pump bracket.

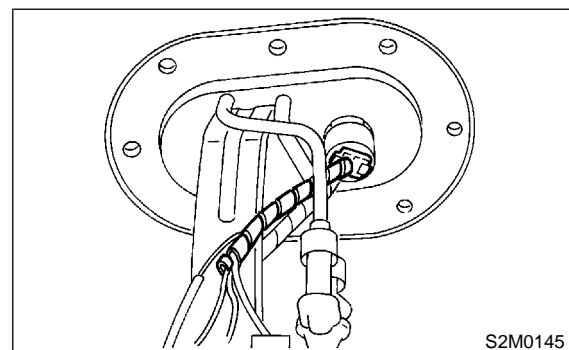

## 8. Main Fuel Level Sensor

12) Remove bolt which installs fuel level sensor on mounting bracket.

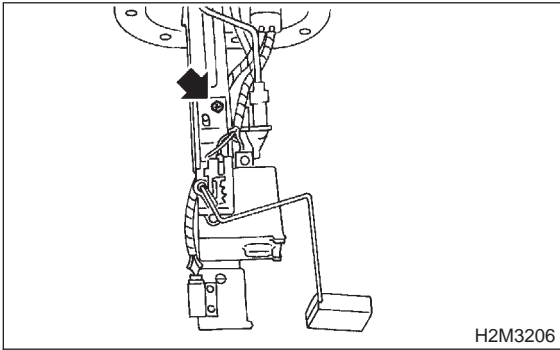

5) Connect connector to fuel pump relay.

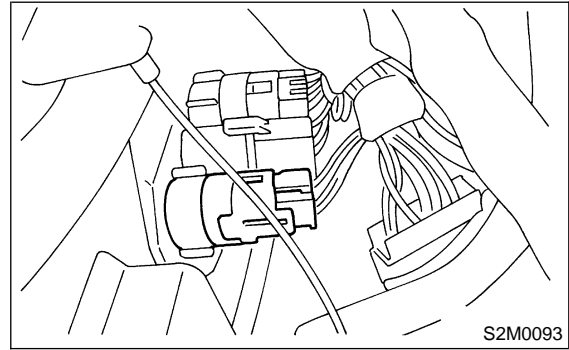

## B: INSTALLATION

### CAUTION:

Leave fuel filler cap open when tightening nuts, to prevent fuel from flowing out through fuel delivery and return pipes. Close fuel filler cap after tightening nuts.

Install in the reverse order of removal. Do the following:

1) Install the fuel level sensor onto the mounting bracket.

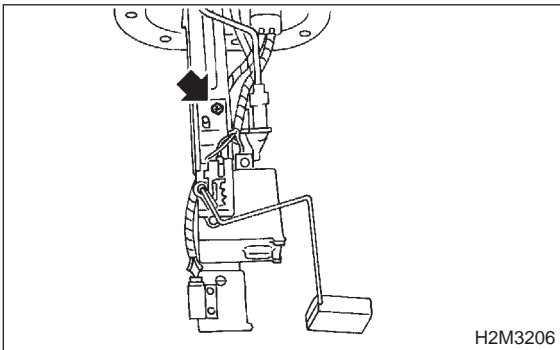

- 2) Always use new gaskets.
- 3) Ensure sealing portion is free from fuel or foreign particles before installation.
- 4) Tighten nuts in alphabetical sequence shown in figure to specified torque.

### Tightening torque:

**$4.4 \pm 1.5 \text{ N}\cdot\text{m}$  ( $0.45 \pm 0.15 \text{ kg}\cdot\text{m}$ ,  $3.3 \pm 1.1 \text{ ft}\cdot\text{lb}$ )**

