

1. Engine

A: GENERAL PRECAUTION

(1) Remove or install engine in an area where chain hoists, lifting devices, etc. are available for ready use.

(2) Be sure not to damage coated surfaces of body panels with tools or stain seats and windows with coolant or oil. Place a cover over fenders, as required, for protection.

(3) Prior to starting work, prepare the following: Service tools, clean cloth, containers to catch coolant and oil, wire ropes, chain hoist, transmission jacks, etc.

(4) Lift-up or lower the vehicle when necessary. Make sure to support the correct positions. <Ref. to 1-3 [G7B0].>

B: REMOVAL

- 1) Set the vehicle on lift arms.
- 2) Open front hood and support with a stay.
- 3) Release fuel pressure.

(1) Disconnect fuel pump relay connector.

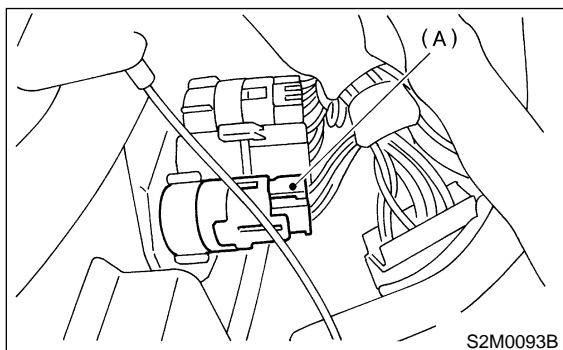

S2M0093B

(A) Fuel pump relay connector

- (2) Start the engine, and run until it stalls.
- (3) After the engine stalls, crank it for five seconds more.
- (4) Turn ignition switch to "OFF".
- (5) Remove filler cap.

4) Disconnect battery ground terminal.

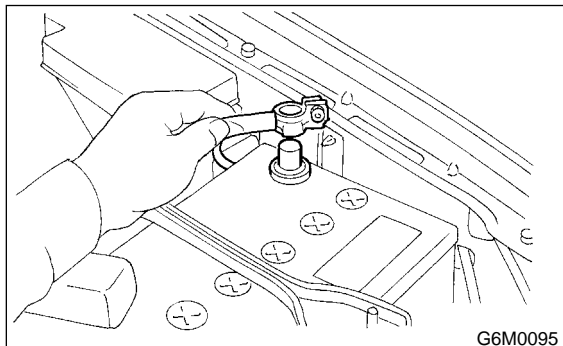

G6M0095

5) Remove under cover.

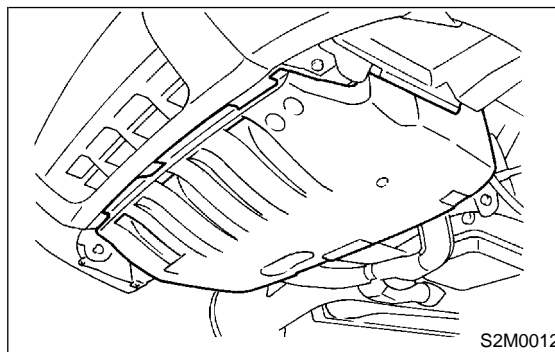

S2M0012

6) Drain coolant.

Set container under the vehicle, and loose drain cock from radiator.

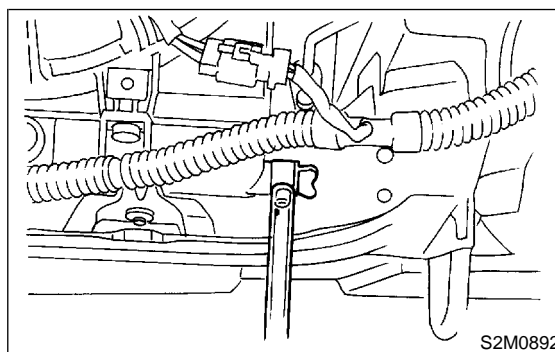

S2M0892

7) Remove cooling system.

(1) Disconnect connectors from radiator main fan and sub fan motors.

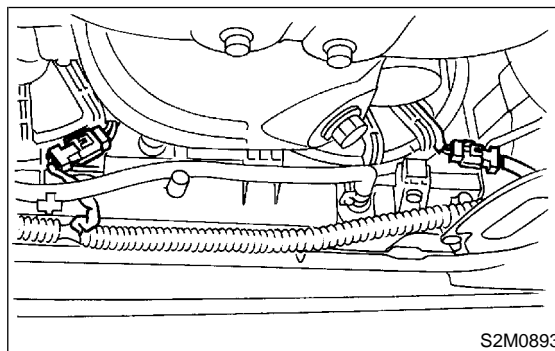

S2M0893

1. Engine

(2) Disconnect radiator outlet hose from thermostat cover, and remove ATF cooler hose from clip of radiator.

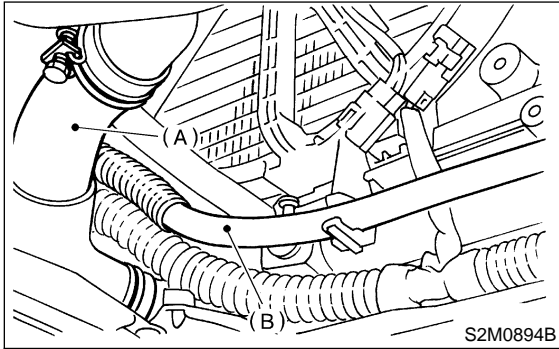

- (A) Radiator outlet hose
- (B) ATF cooler hose

(3) Disconnect ATF cooler hoses from radiator. (AT vehicles)

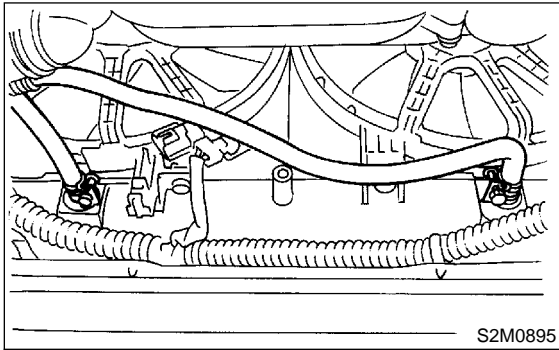

- (4) Lower the vehicle.
- (5) Remove V-belt covers.

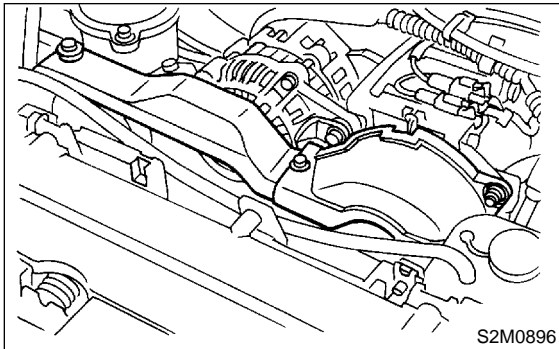

(6) Disconnect radiator inlet hose from radiator.

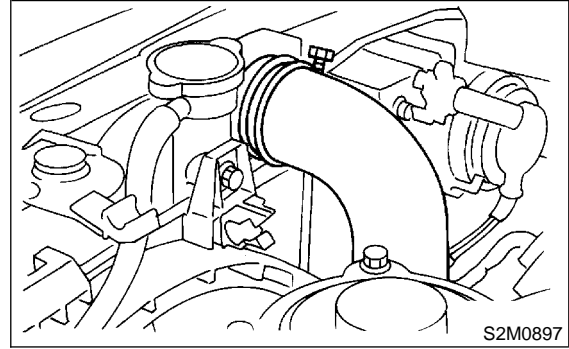

(7) Remove radiator upper bracket, and remove radiator assembly from vehicle.

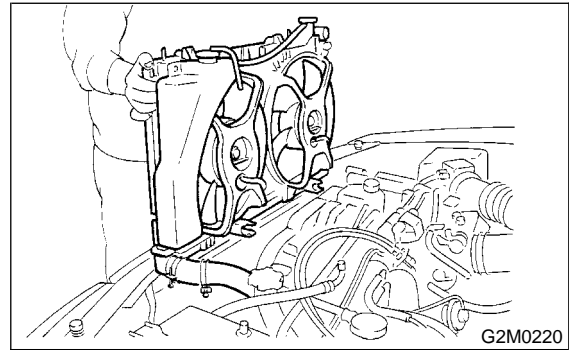

8) Collect refrigerant, and remove flexible hoses. (With A/C)

- (1) Place and connect the attachment hose to the refrigerant recycle system.
- (2) Collect refrigerant from A/C system.
- (3) Disconnect A/C flexible hoses from A/C compressor.

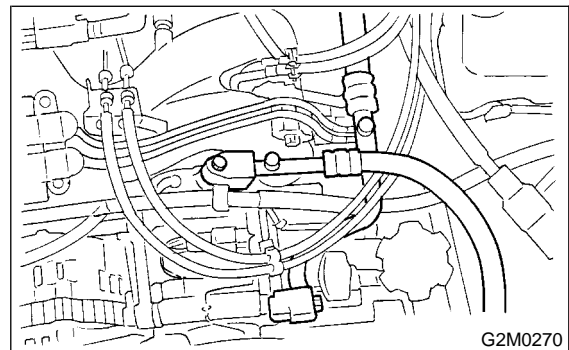

9) Remove air intake system.
Remove air intake duct with air cleaner case.

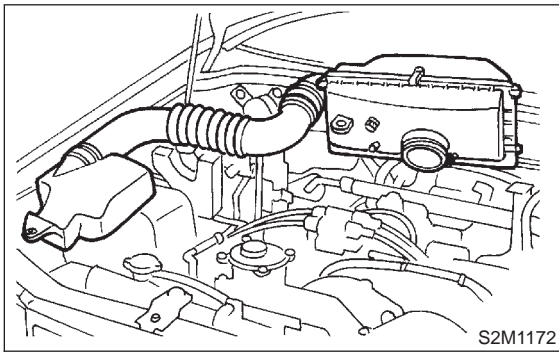

10) Remove air cleaner case stay.
● MT vehicles

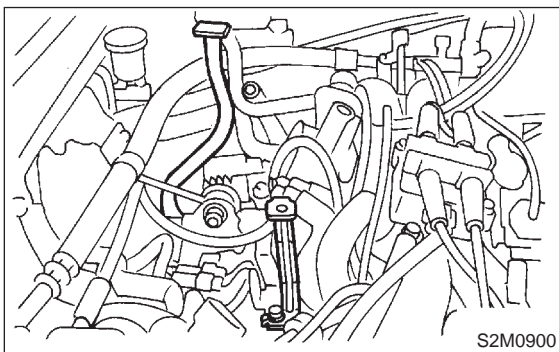

● AT vehicles

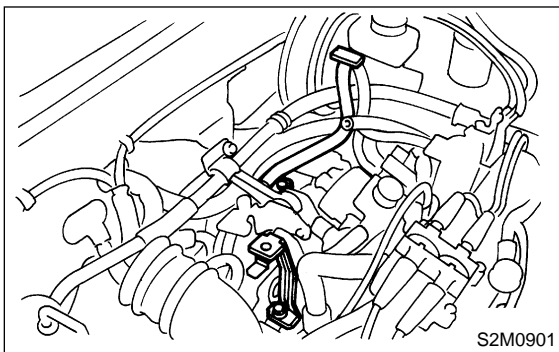

11) Disconnect the following connectors and cables.

(1) Front oxygen sensor connector

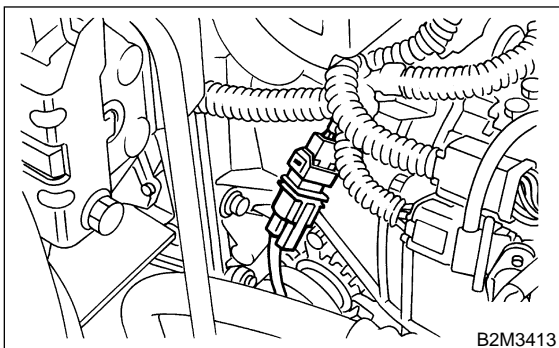

(2) Engine ground terminal

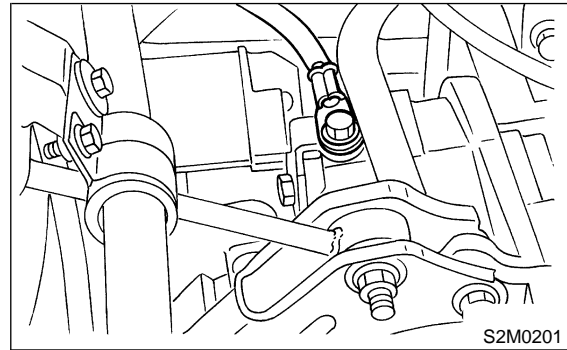

(3) Engine harness connector

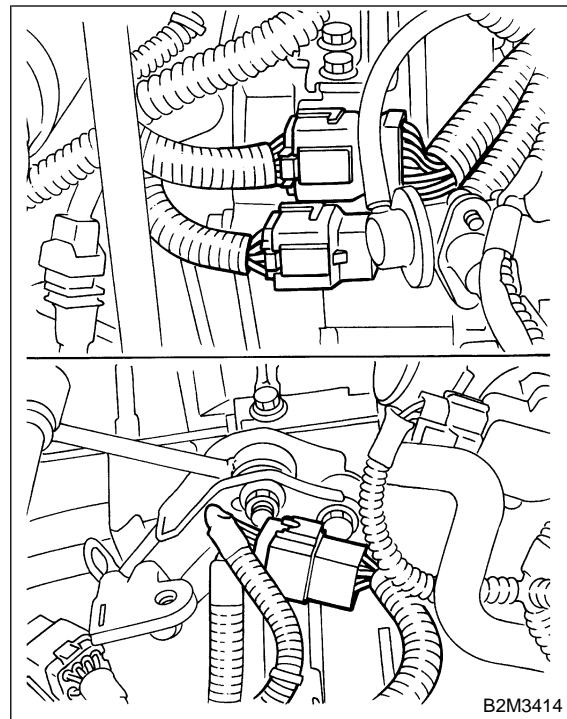

(4) Generator connector, terminal and A/C compressor connectors (With A/C)

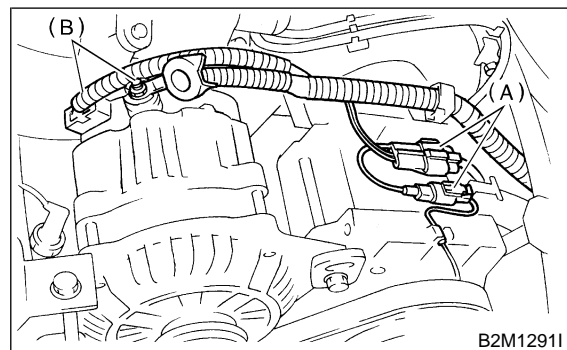

(A) A/C compressor connectors
(B) Generator connector and terminal

1. Engine

(5) Accelerator cable and cruise control cable

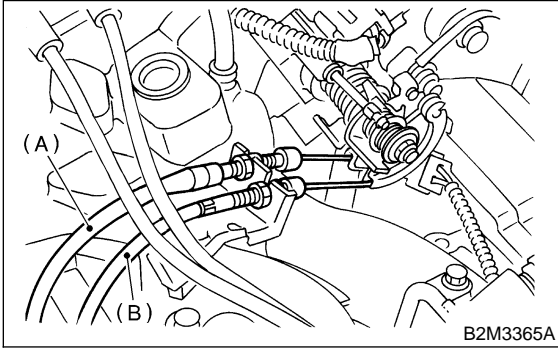

- (A) Accelerator cable
- (B) Cruise control cable

12) Disconnect the following hoses.

(1) Brake booster vacuum hose

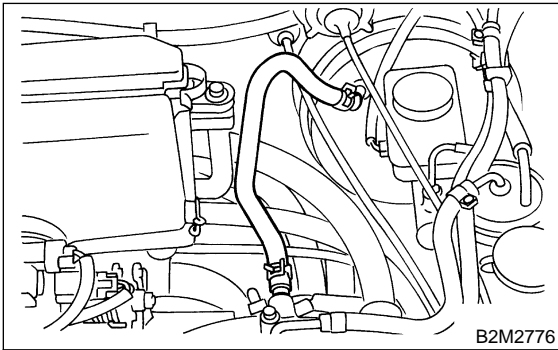

(2) Heater inlet and outlet hoses

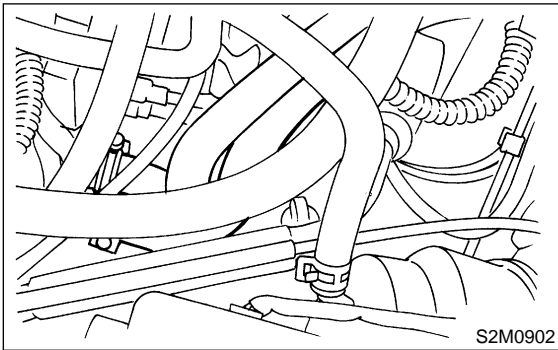

(3) Cruise control vacuum hose

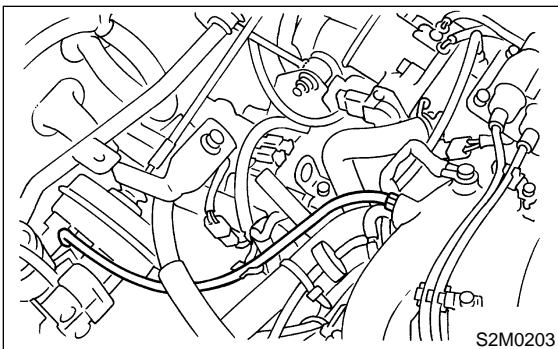

13) Remove power steering pump.

(1) Loosen lock bolt and slider bolt, and remove front side V-belt.

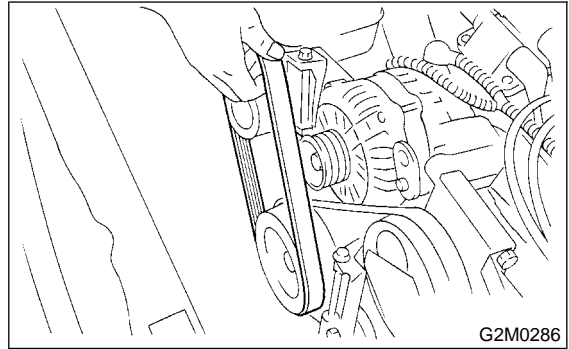

(2) Remove power steering pipe bracket.

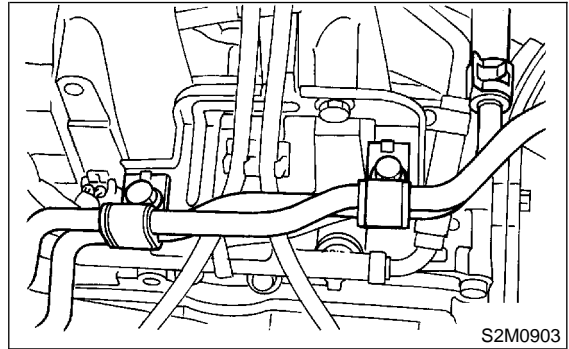

(3) Remove bolts which install power steering pump from bracket.

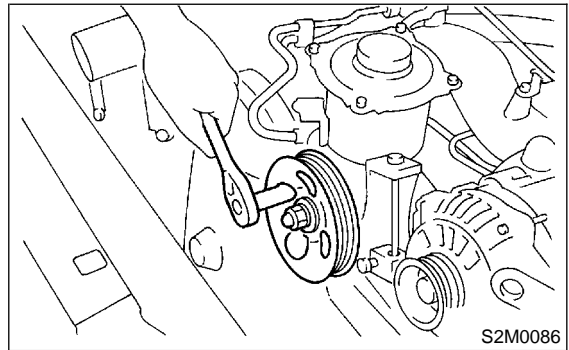

(4) Place power steering pump on the right side wheel apron.

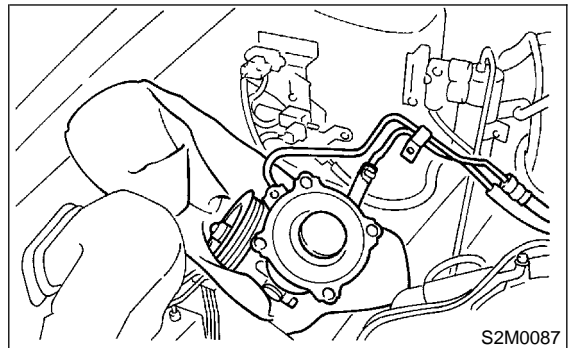

14) Remove front exhaust pipe and center exhaust pipe.

- (1) Lift-up the vehicle.
- (2) Disconnect connector from rear oxygen sensor.

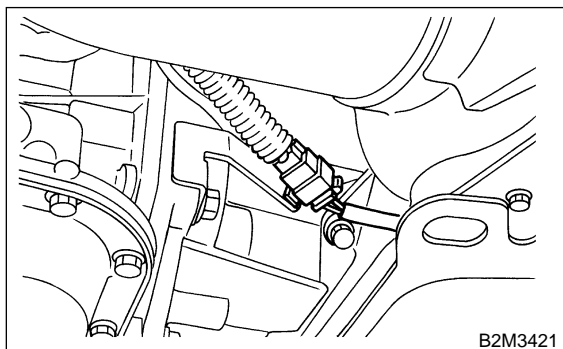

(3) Remove nuts which install front exhaust pipe onto engine.

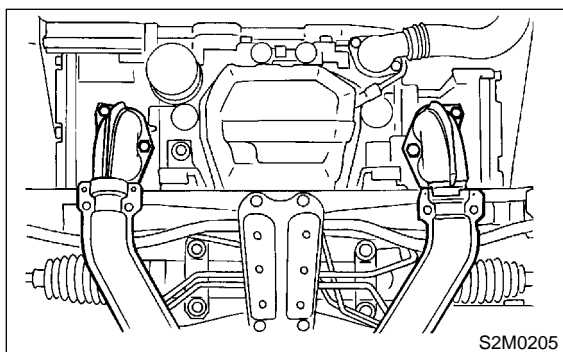

(4) Separate center exhaust pipe from rear exhaust pipe.

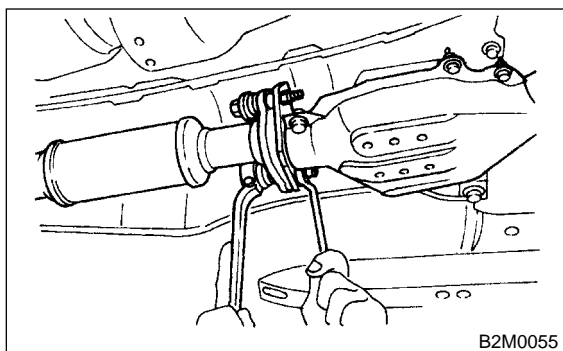

(5) Remove bolt which installs center exhaust pipe on hunger bracket.

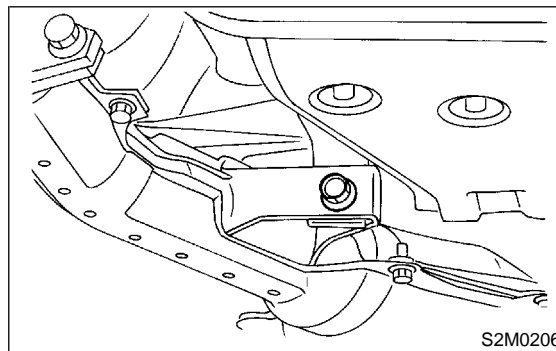

(6) Take off front and center exhaust pipes.

CAUTION:
Exhaust pipe will drop when all bolts are removed. So, hold it when removing the last bolt.

15) Remove nuts which hold lower side of transmission to engine.

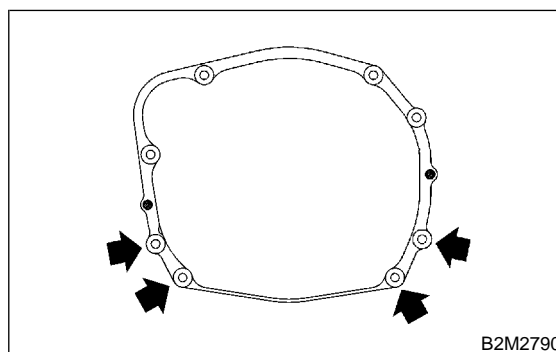

16) Remove nuts which install front cushion rubber onto front crossmember.

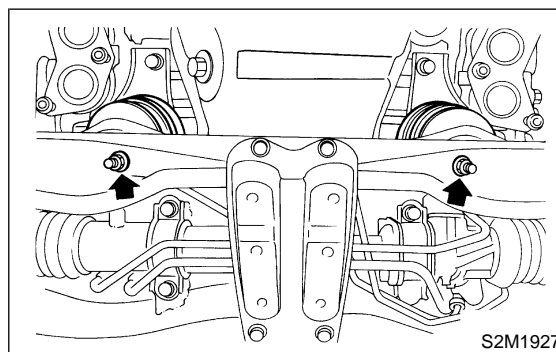

17) Separate torque converter from drive plate.
(AT vehicles)

- (1) Lower the vehicle.
- (2) Remove service hole plug.

1. Engine

(3) Remove bolts which hold torque converter to drive plate.

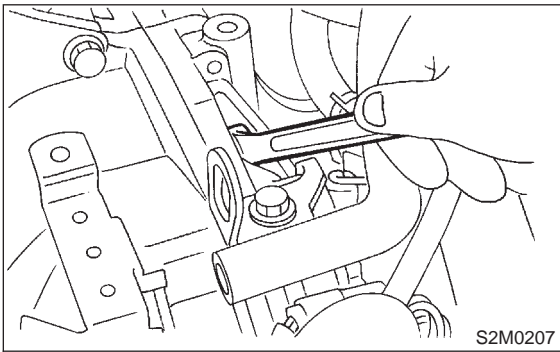

20) Support engine with a lifting device and wire ropes.

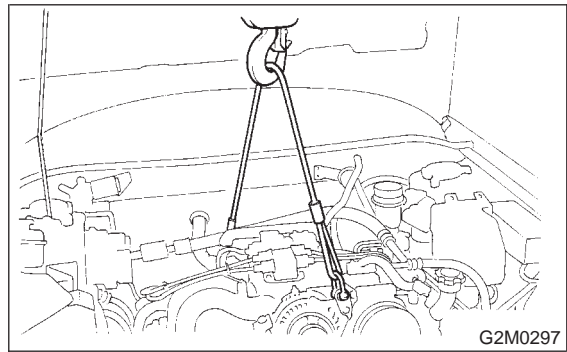

(4) Remove other bolts while rotating the engine using ST.

ST 499977100 CRANK PULLEY WRENCH

18) Remove pitching stopper.

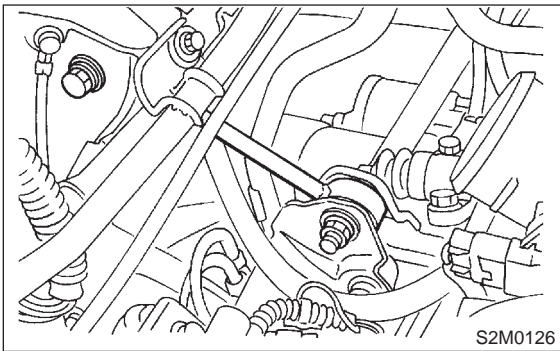

21) Support transmission with a garage jack.

CAUTION:

Before moving engine away from transmission, check to be sure no work has been overlooked. Doing this is very important in order to facilitate re-installation and because transmission lowers under its own weight.

19) Disconnect fuel delivery hose, return hose and evaporation hose.

CAUTION:

- Disconnect hose with its end wrapped with cloth to prevent fuel from splashing.
- Catch fuel from hose into container.

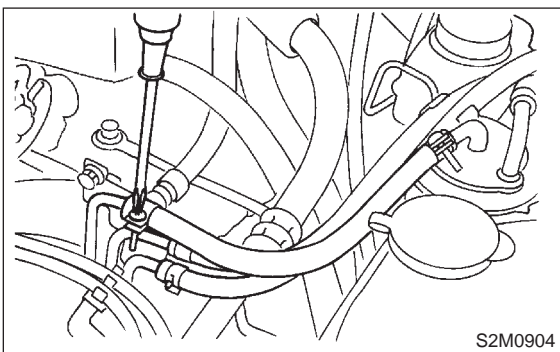
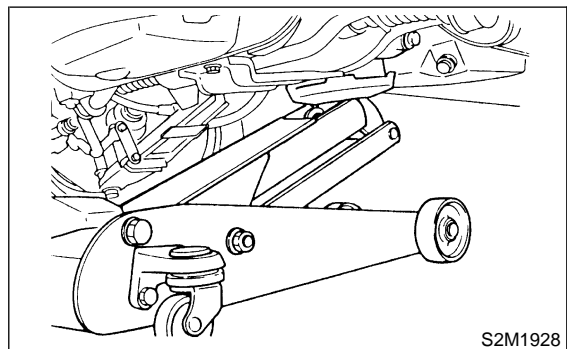

22) Separation of engine and transmission.

- (1) Remove starter. <Ref. to 6-1 [W1A0].>
- (2) Install ST to torque converter clutch case. (AT model)

ST 498277200 STOPPER SET

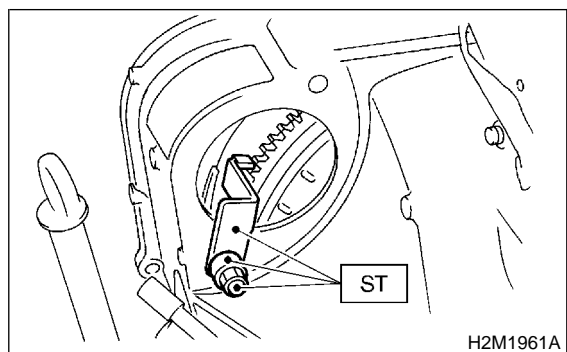

(3) Remove bolts which hold upper side of transmission to engine.

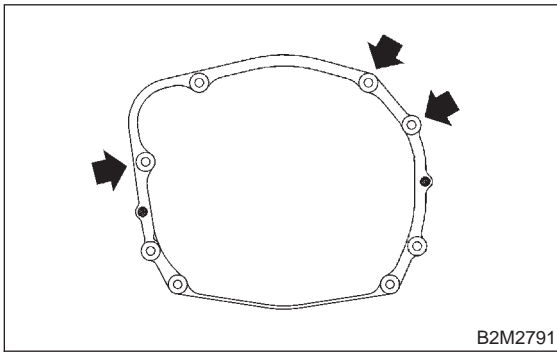

(1) Position engine in engine compartment and align it with transmission.

CAUTION:

Be careful not to damage adjacent parts or body panels with crank pulley, oil pressure gauge, etc.

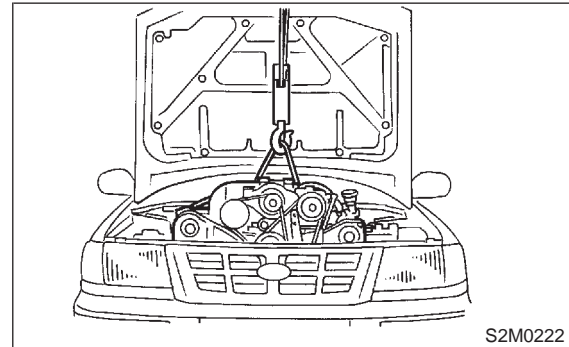

23) Remove engine from vehicle

- (1) Slightly raise engine.
- (2) Raise transmission with garage jack.
- (3) Move engine horizontally until mainshaft is withdrawn from clutch cover.
- (4) Slowly move engine away from engine compartment.

CAUTION:

Be careful not to damage adjacent parts or body panels with crank pulley, oil pressure gauge, etc.

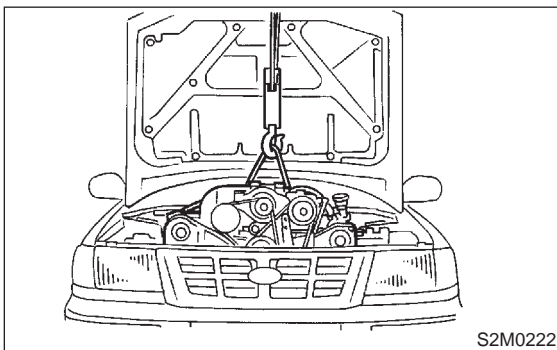

(2) Apply a small amount of grease to spline of mainshaft.

2) Connect engine and transmission.

(1) Remove ST from torque converter clutch case. (AT vehicles)

NOTE:

Be careful not to drop the ST into the torque converter clutch case when removing ST.

ST 498277200 STOPPER SET

(2) Install starter.

<Ref. to 6-1 [W1A0].>

(3) Tighten bolt which holds right upper side of transmission to engine.

Tightening torque:

50±4 N-m (5.1±0.4 kg-m, 36.9±2.9 ft-lb)

C: INSTALLATION

1) Install engine onto transmission.

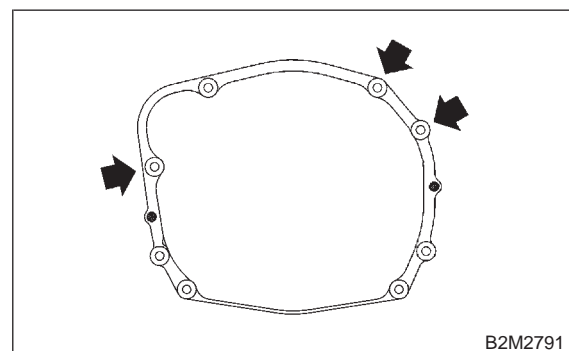

1. Engine

3) Remove lifting device and wire ropes.

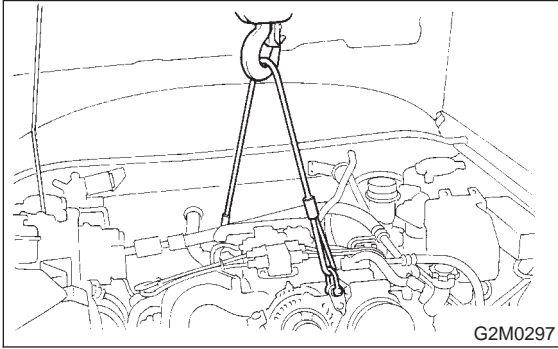

4) Remove garage jack.
5) Install pitching stopper.

Tightening torque:

T1: 49±5 N·m (5.0±0.5 kg·m, 36.2±3.6 ft·lb)

T2: 57±10 N·m (5.8±1.0 kg·m, 42±7 ft·lb)

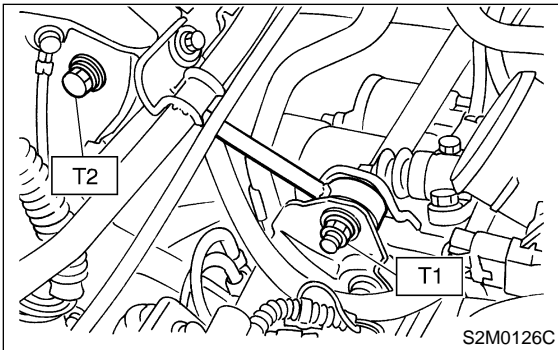

6) Install torque converter onto drive plate. (AT vehicles)

- (1) Tighten bolts which hold torque converter to drive plate.
- (2) Tighten other bolts while rotating the engine by using ST.

ST 499977100 CRANK PULLEY WRENCH

CAUTION:

Be careful not to drop bolts into torque converter housing.

Tightening torque:

25±2 N·m (2.5±0.2 kg·m, 18.1±1.4 ft·lb)

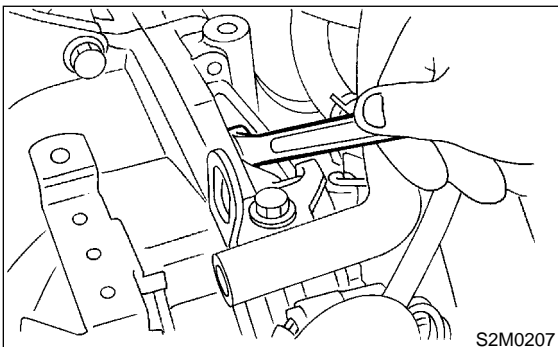

(3) Clog plug onto service hole.

7) Install power steering pump on bracket.
(1) Install power steering pump on bracket, and tighten bolts.

Tightening torque:

39±10 N·m (4.0±1.0 kg·m, 29±7 ft·lb)

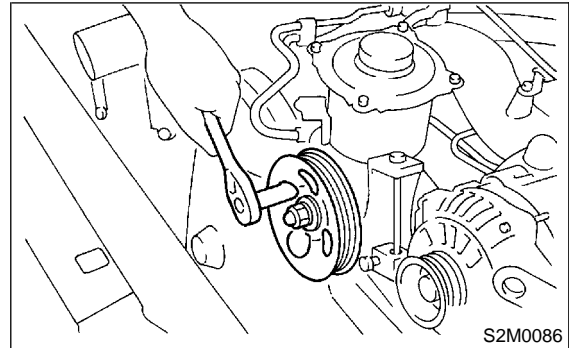

(2) Install power steering pipe bracket on right side intake manifold, and install spark plug codes.

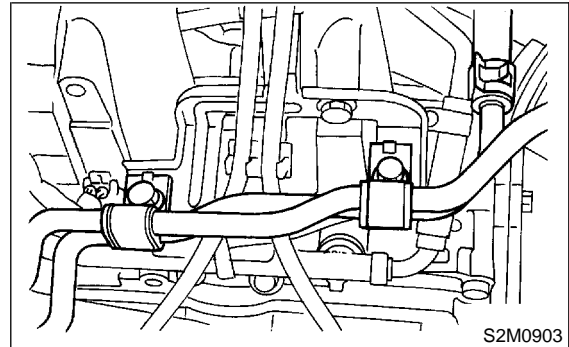

(3) Install front side V-belt, and adjust it.
<Ref. to 1-5 [G200].>

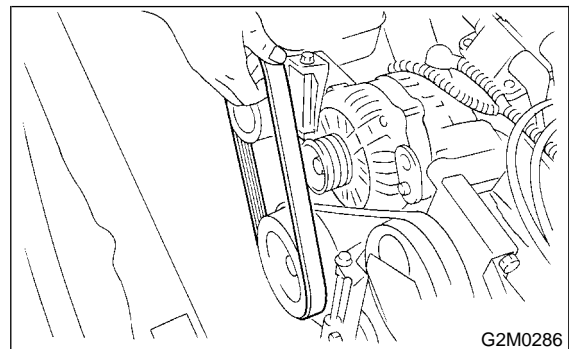

8) Tighten nuts which hold lower side of transmission to engine.

Tightening torque:

$50 \pm 4 \text{ N}\cdot\text{m}$ ($5.1 \pm 0.4 \text{ kg}\cdot\text{m}$, $36.9 \pm 2.9 \text{ ft}\cdot\text{lb}$)

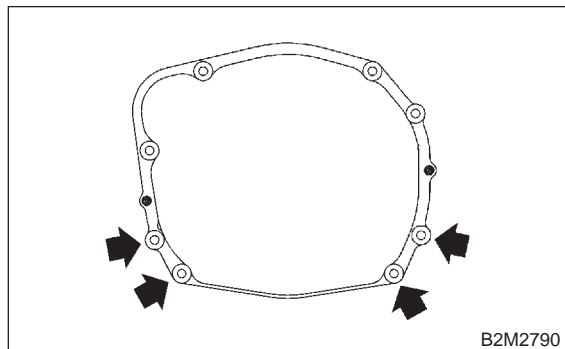

9) Tighten nuts which install front cushion rubber onto crossmember.

Tightening torque:

$83 \pm 15 \text{ N}\cdot\text{m}$ ($8.5 \pm 1.5 \text{ kg}\cdot\text{m}$, $61 \pm 11 \text{ ft}\cdot\text{lb}$)

CAUTION:

Be sure to tighten front cushion rubber mounting bolts in the innermost elliptical hole in the front crossmember.

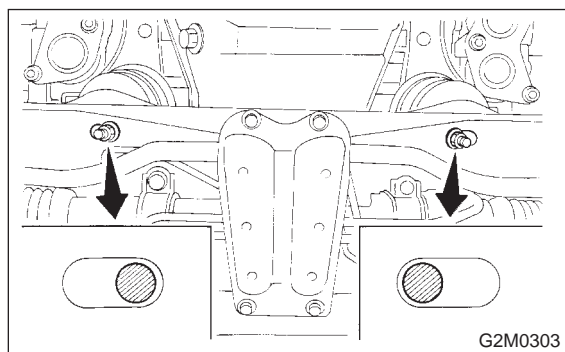

10) Install front exhaust pipe and center exhaust pipe. <Ref. to 2-9 [W1B0].>

11) Connect rear oxygen sensor connector.

12) Connect the following hoses.

- (1) Fuel delivery hose, return hose and evaporation hose
- (2) Heater inlet and outlet hoses
- (3) Brake booster vacuum hose
- (4) Cruise control vacuum hose

13) Connect the following connectors.

- (1) Engine ground terminal
- (2) Engine harness connectors
- (3) Front oxygen sensor connector
- (4) Generator connector and terminal
- (5) A/C compressor connectors (With A/C)

14) Connect the following cables.

- (1) Accelerator cable
- (2) Cruise control cables (With cruise control)

CAUTION:

After connecting each cable, adjust them.

15) Install air intake system.

- (1) Install air cleaner case stay.
- (2) Install air intake duct with air cleaner case.

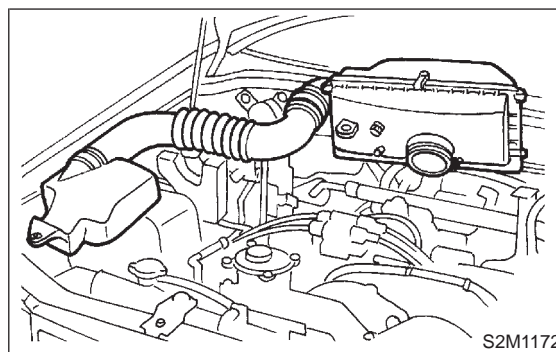

16) Install A/C flexible hoses. (With A/C) <Ref. to 4-7 [W16A0].>

CAUTION:

Use new O-rings.

Tightening torque:

$25 \pm 7 \text{ N}\cdot\text{m}$ ($2.5 \pm 0.7 \text{ kg}\cdot\text{m}$, $18.1 \pm 5.1 \text{ ft}\cdot\text{lb}$)

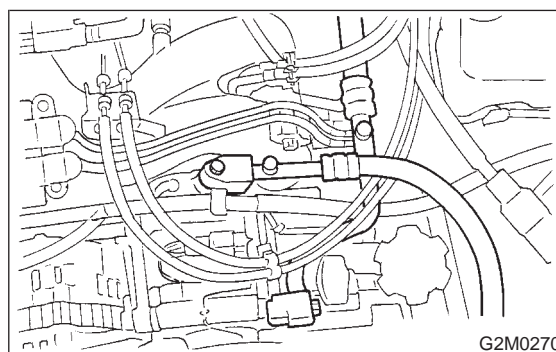

17) Install cooling system.

- (1) Attach radiator lower cushions to radiator.

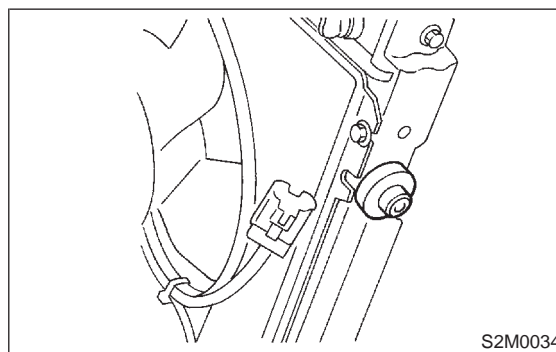

1. Engine

(2) Install radiator while fitting radiator pins to cushions.

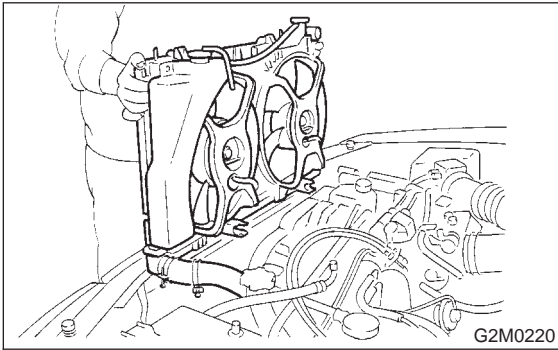

(3) Install radiator brackets and tighten bolts.

Tightening torque:

12±3 N·m (1.2±0.3 kg·m, 8.7±2.2 ft·lb)

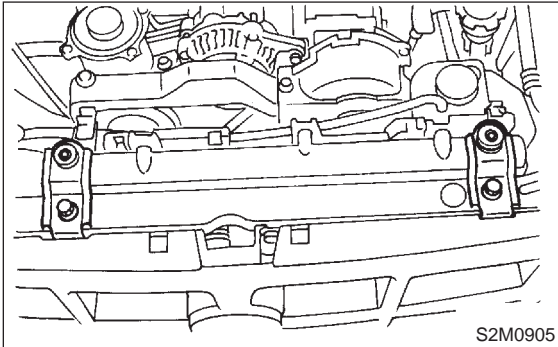

(4) Connect radiator inlet hose.

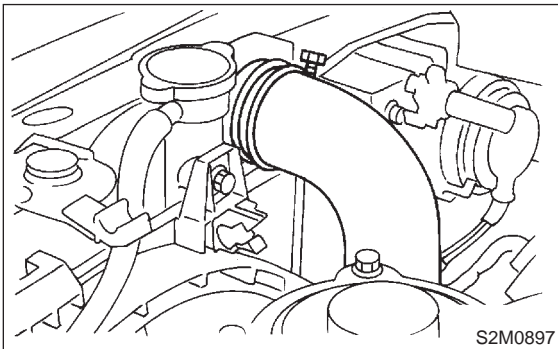

(5) Connect ATF cooler hoses. (AT vehicles)

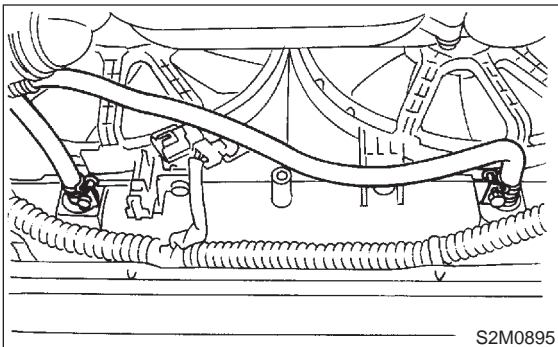

(6) Connect radiator outlet hose to thermostat cover.

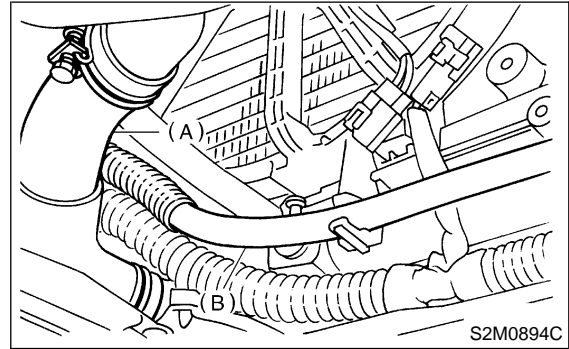

(A) Radiator outlet hose

(B) ATF cooler hose

(7) Connect radiator fan motor connector.

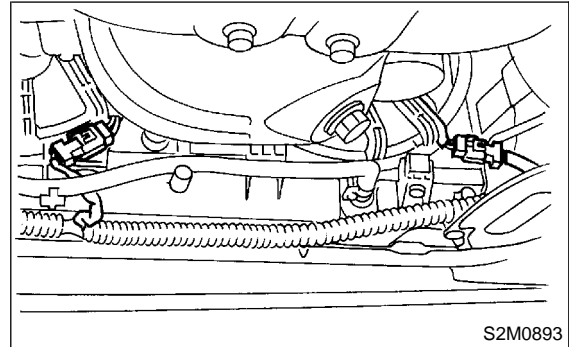

(8) Install V-belt covers.

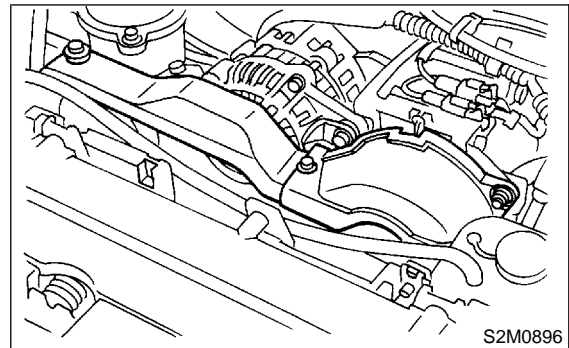

18) Install battery in the vehicle, and connect terminal.

19) Fill coolant.

<Ref. to 2-5 [W9B0].>

20) Check ATF level and correct if necessary. (AT vehicles)

<Ref. to 3-2 [W1B1].>

21) Charge A/C system with refrigerant.

<Ref. to 4-7 [W7H0].>

22) Remove front hood stay, and close front hood.

23) Take off the vehicle from lift arms.