

## 1. Precaution

### A: SUPPLEMENTAL RESTRAINT SYSTEM "AIRBAG"

Airbag system wiring harness is routed near the ABS sensor, ABS control module and hydraulic control unit.

#### CAUTION:

- All airbag system wiring harness and connectors are yellow. Do not use electrical test equipment on these circuit.
- Be careful not to damage airbag system wiring harness when servicing the ABS sensor, ABS control module and hydraulic control unit.

## 2. Pre-inspection

Before performing diagnostics, check the following items which might affect ABS problems:

### A: MECHANICAL INSPECTION

#### 1. POWER SUPPLY

- 1) Measure battery voltage and specific gravity of electrolyte.

*Standard voltage: 12 V, or more*

*Specific gravity: Above 1.260*

- 2) Check the condition of the main and other fuses, and harnesses and connectors. Also check for proper grounding.

#### 2. BRAKE FLUID

- 1) Check brake fluid level.
- 2) Check brake fluid leakage.

#### 3. BRAKE DRAG

Check brake drag. <Ref. to 4-4 [K100].>

#### 4. BRAKE PAD AND ROTOR

Check brake pad and rotor. <Ref. to 4-4 [K100].>

#### 5. TIRE SPECIFICATIONS, TIRE WEAR AND AIR PRESSURE

Check tire specifications, tire wear and air pressure. <Ref. to 4-2 [S100].> and <Ref. to 4-2 [S200].>

## 1. Precaution

### A: SUPPLEMENTAL RESTRAINT SYSTEM "AIRBAG"

Airbag system wiring harness is routed near the ABS sensor, ABS control module and hydraulic control unit.

#### CAUTION:

- All airbag system wiring harness and connectors are yellow. Do not use electrical test equipment on these circuit.
- Be careful not to damage airbag system wiring harness when servicing the ABS sensor, ABS control module and hydraulic control unit.

## 2. Pre-inspection

Before performing diagnostics, check the following items which might affect ABS problems:

### A: MECHANICAL INSPECTION

#### 1. POWER SUPPLY

- 1) Measure battery voltage and specific gravity of electrolyte.

*Standard voltage: 12 V, or more*

*Specific gravity: Above 1.260*

- 2) Check the condition of the main and other fuses, and harnesses and connectors. Also check for proper grounding.

#### 2. BRAKE FLUID

- 1) Check brake fluid level.
- 2) Check brake fluid leakage.

#### 3. BRAKE DRAG

Check brake drag. <Ref. to 4-4 [K100].>

#### 4. BRAKE PAD AND ROTOR

Check brake pad and rotor. <Ref. to 4-4 [K100].>

#### 5. TIRE SPECIFICATIONS, TIRE WEAR AND AIR PRESSURE

Check tire specifications, tire wear and air pressure. <Ref. to 4-2 [S100].> and <Ref. to 4-2 [S200].>

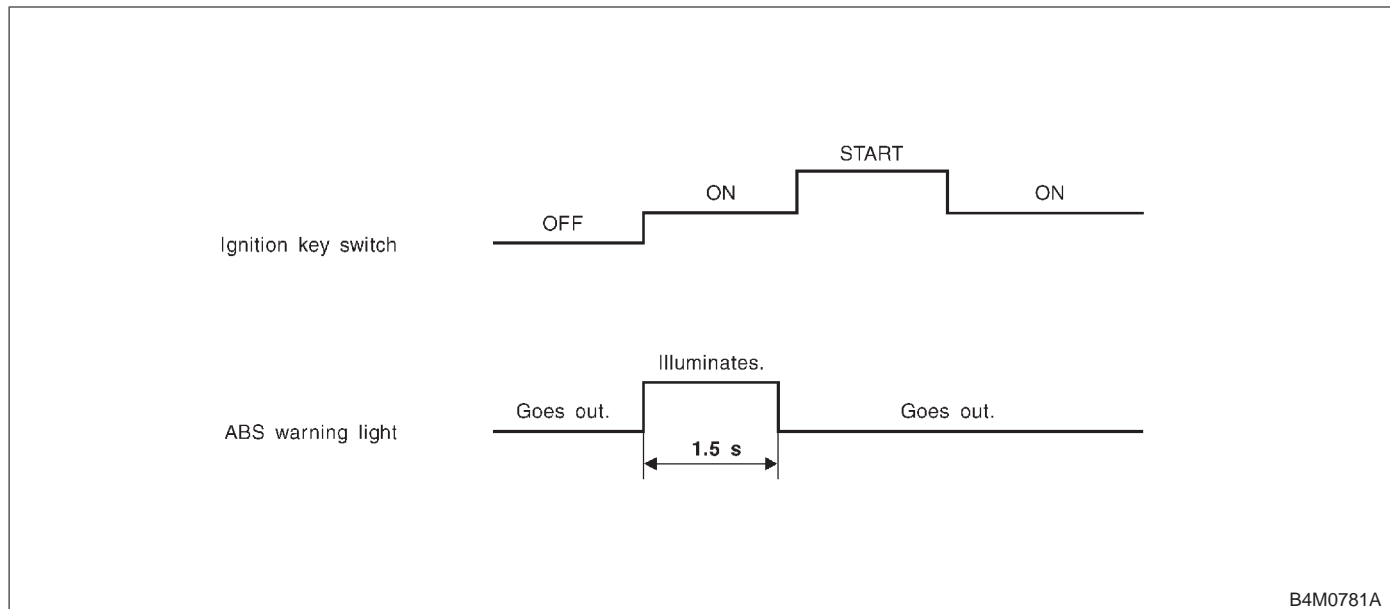
**B: ELECTRICAL INSPECTION****1. WARNING LIGHT ILLUMINATION PATTERN**

1) When the ABS warning light does not illuminate in accordance with this illumination pattern, there must be an electrical malfunction.

2) When the ABS warning light remains constantly OFF, repair the ABS warning light circuit or diagnosis circuit. <Ref. to 4-4 [T7A0].>

**NOTE:**

Even though the ABS warning light does not go out 1.5 seconds after it illuminates, the ABS system operates normally when the warning light goes out while driving at approximately 12 km/h (7 MPH). However, the Anti-lock brakes do not work while the ABS warning light is illuminated.

### 3. Electrical Components Location

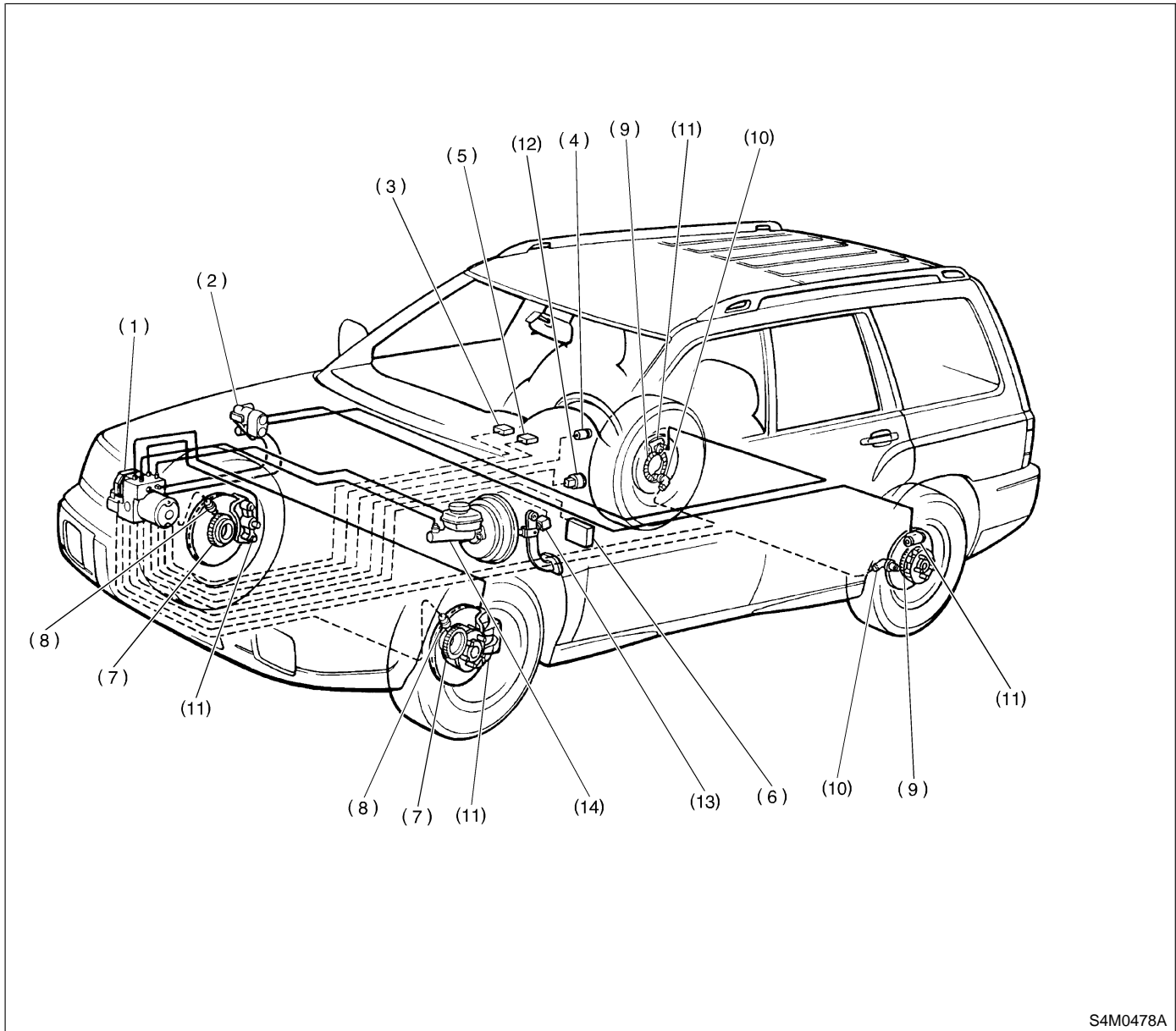



S4M0478A

- (1) ABS control module and hydraulic control unit (ABSCM&H/U)
- (2) Proportioning valve
- (3) Diagnosis connector
- (4) ABS warning light
- (5) Data link connector (for SUBARU select monitor)

- (6) Automatic transmission control module
- (7) Front tone wheel
- (8) Front ABS sensor
- (9) Rear tone wheel
- (10) Rear ABS sensor
- (11) Wheel cylinder

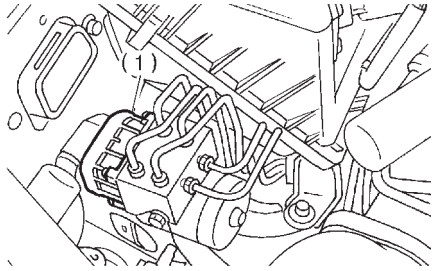
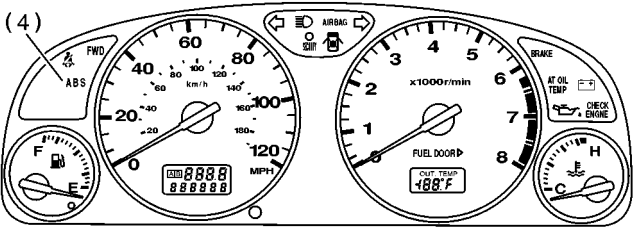
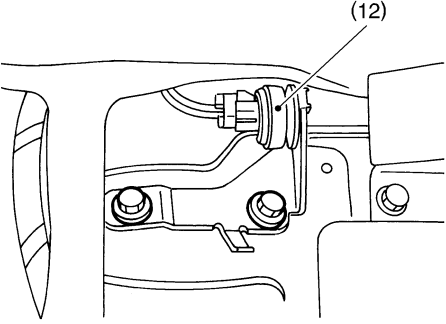
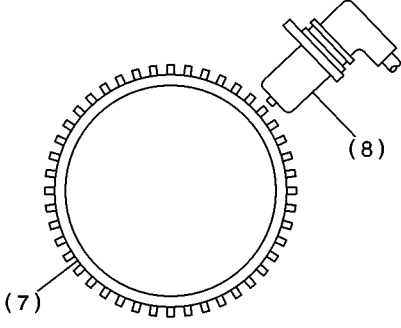
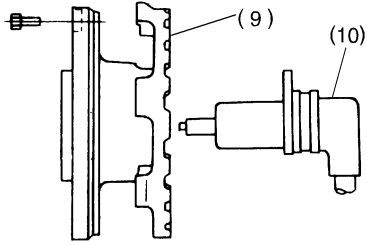
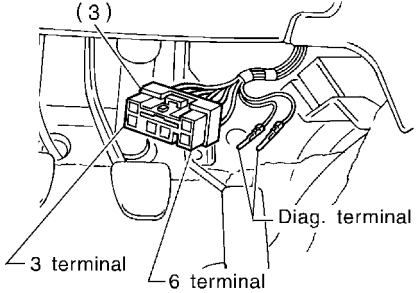
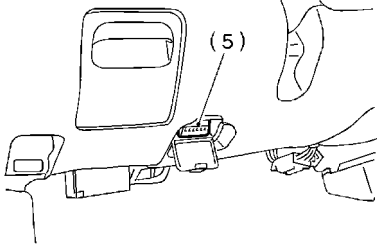
- (12) G sensor
- (13) Brake switch
- (14) Master cylinder

 <p>Diagram showing the location of the ABS sensor assembly, labeled (1).</p>	 <p>Diagram of the instrument cluster showing the location of the ABS indicator lamp, labeled (4).</p>
 <p>Diagram showing the location of the ABS sensor connector, labeled (12).</p>	 <p>Diagram showing the ABS sensor (8) and the ABS ring (7).</p>
 <p>Diagram showing the ABS sensor (9) and the ABS ring (10).</p>	 <p>Diagram showing the location of the ABS sensor connector, labeled (3), and the diagnostic terminal (Diag. terminal). The diagram also shows the 3 terminal and 6 terminal.</p>
 <p>Diagram showing the location of the ABS sensor connector, labeled (5).</p>	 <p>SUBARU.</p>

## 4. Schematic

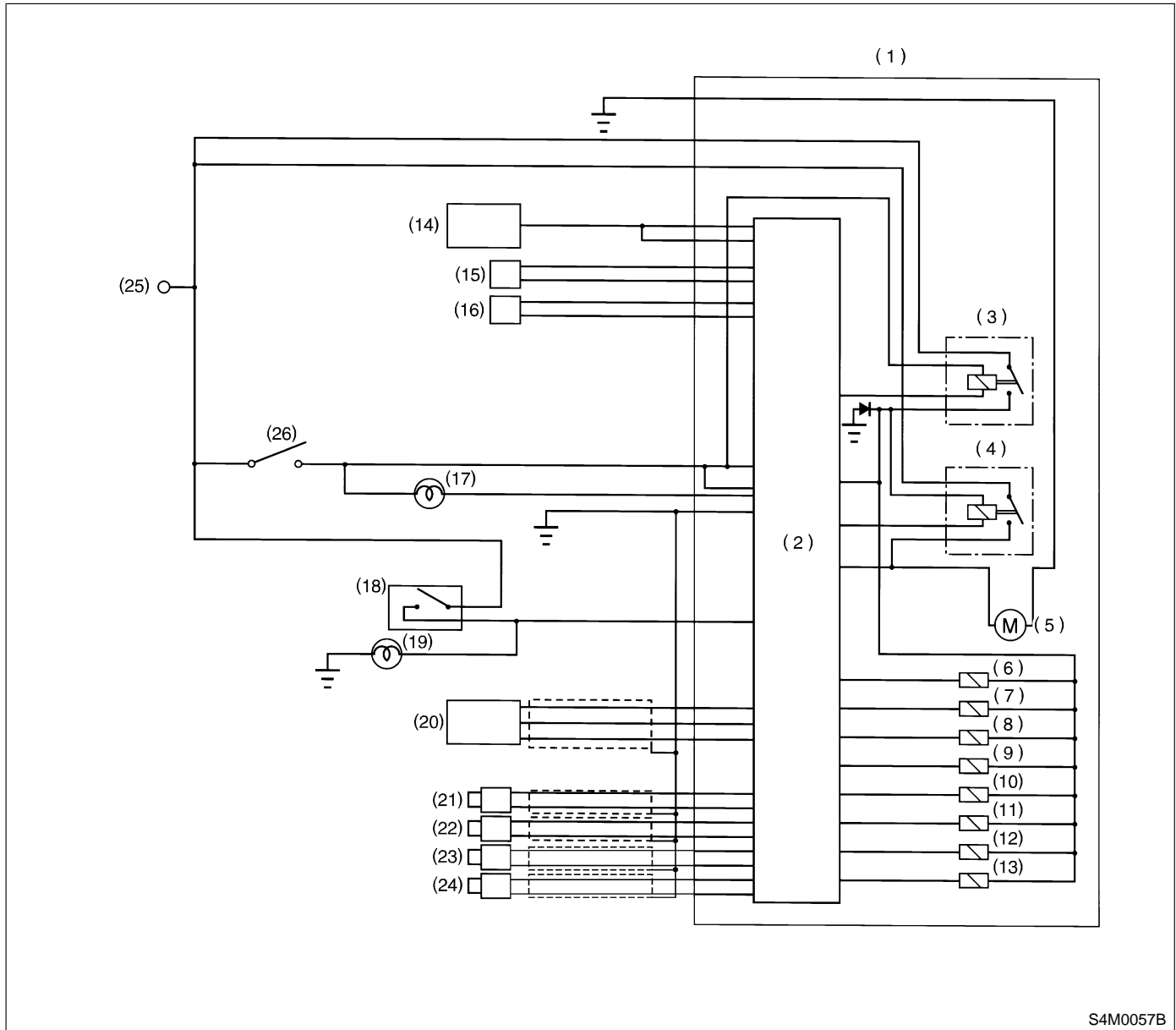

- |   |  |                             |
|---|--|-----------------------------|
| (1) ABS control module and hydraulic control unit (ABSCM&H/U) | (10) Rear left inlet solenoid valve        | (19) Stop light             |
| (2) ABS control module area                                   | (11) Rear left outlet solenoid valve       | (20) G sensor               |
| (3) Valve relay   | (12) Rear right inlet solenoid valve       | (21) Front left ABS sensor  |
| (4) Motor relay   | (13) Rear right outlet solenoid valve      | (22) Front right ABS sensor |
| (5) Motor   | (14) Automatic transmission control module | (23) Rear left ABS sensor   |
| (6) Front left inlet solenoid valve                           | (15) Diagnosis connector                   | (24) Rear right ABS sensor  |
| (7) Front left outlet solenoid valve                          | (16) Data link connector                   | (25) Battery                |
| (8) Front right inlet solenoid valve                          | (17) ABS warning light                     | (26) Ignition switch        |
| (9) Front right outlet solenoid valve                         | (18) Stop light switch                     |                             |

MEMO:

## 5. Control Module I/O Signal

### A: I/O SIGNAL VOLTAGE

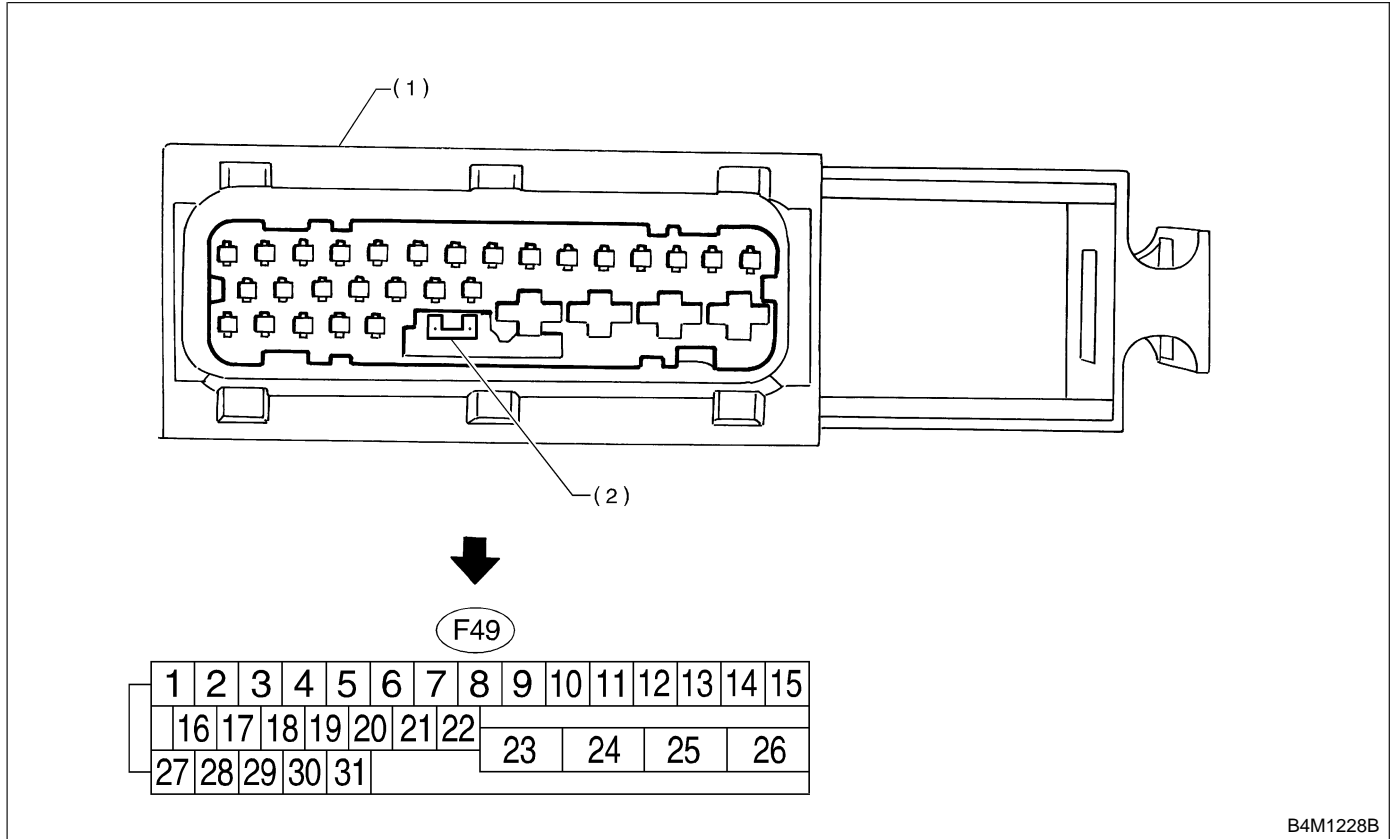

(1) ABS control module and hydraulic control unit connector

(2) Connector switch

**NOTE:**

- The terminal numbers in the ABS control module and hydraulic control unit connector are as shown in the figure.
- When the connector is removed from the ABSCM&H/U, the connector switch closes the circuit between terminal No. 21 and No. 23. The ABS warning light illuminates.



Contents		Terminal No. (+)-( )	Input/Output signal
			Measured value and measuring conditions
ABS sensor*2 (Wheel speed sensor)	Front left wheel	9-10	0.12 — 1 V (When it is 20 Hz.)
	Front right wheel	11-12	
	Rear left wheel	7-8	
	Rear right wheel	13-15	
Valve relay power supply		24-23	10 — 15 V when ignition switch is ON.
Motor relay power supply		25-23	10 — 15 V when ignition switch is ON.
G sensor*2 (AWD model only)	power supply	30-28	4.75 — 5.25 V
	ground	28	—
	output	6-28	2.3±0.2 V when vehicle is in horizontal position.
Stop light switch*1		2-23	Less than 1.5 V when the stop light is OFF and, 10 — 15 V when the stop light is ON.
ABS warning light*2		21-23	Less than 1.5 V during 1.5 seconds when ignition switch is ON, and 10 — 15 V after 1.5 seconds.
AT ABS signal*2 (AT model only)		3-23	Between 5.5 V and 15 V when the ABS control does not operate still and less than 1.5 V when ABS operates.
ABS operation signal monitor*2 (AT model only)		31-23	Between 5.5 V and 15 V when the ABS control does not operate still and less than 1.5 V when ABS operates.
Select monitor*2	Data is received.	20-23	Less than 1.5 V when no data is received.
	Data is sent.	5-23	4.75 — 5.25 V when no data is sent.
ABS diagnosis connector*2	Terminal No. 3	29-23	10 — 15 V when ignition switch is ON.
	Terminal No. 6	4-23	10 — 15 V when ignition switch is ON.
Power supply*1		1-23	10 — 15 V when ignition switch is ON.
Grounding line		23	—
Grounding line		26	—

\*1: Measure the I/O signal voltage after removing the connector from the ABSCM&H/U terminal.

\*2: Measure the I/O signal voltage at connector (F2) or (F55).

B: I/O SIGNAL DIAGRAM

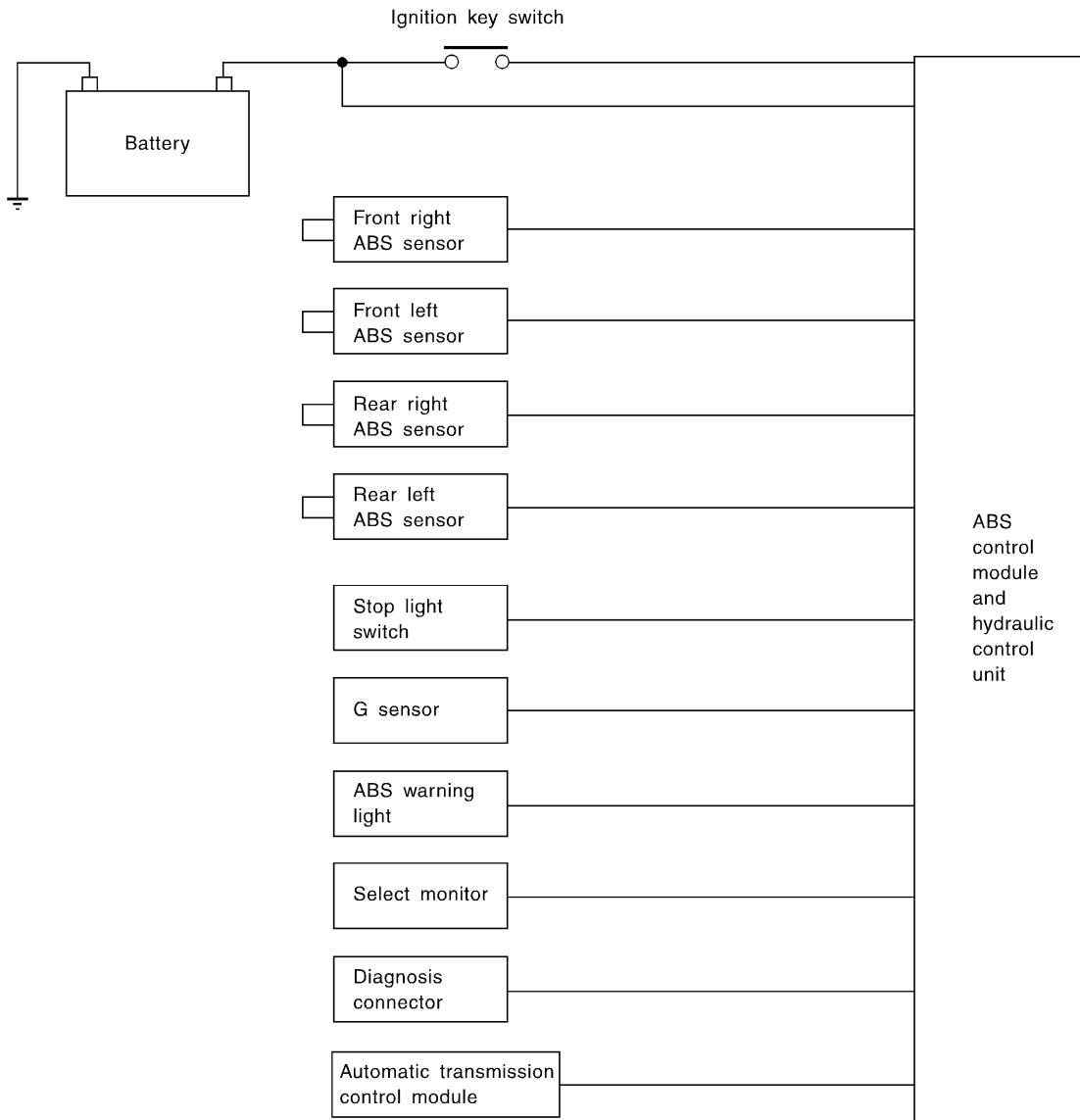

# 6. Diagnostics Chart for On-board Diagnosis System

## A: BASIC DIAGNOSTICS PROCEDURE

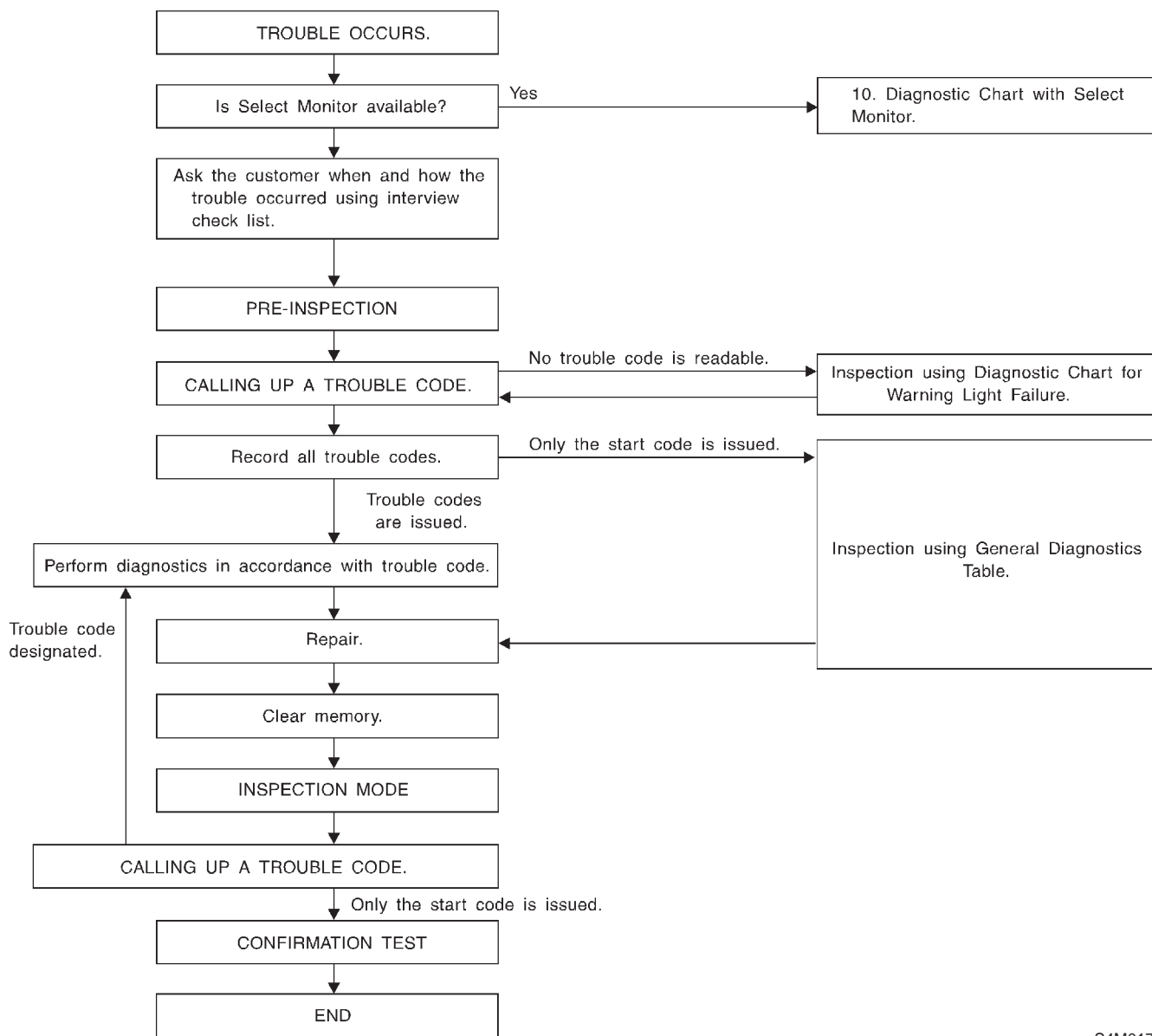

S4M0179A

**CAUTION:**

Remove foreign matter (dust, water, etc.) from the ABSCM&H/U connector during removal and installation.

**NOTE:**

- To check harness for broken wires or short circuits, shake it while holding it or the connector.
- When ABS warning light illuminates, read and record trouble code indicated by ABS warning light.

## B: CHECK LIST FOR INTERVIEW

Check The Following Items About The Vehicle's State.

### 1. THE STATE OF THE ABS WARNING LIGHT

ABS warning light comes on.	<input type="checkbox"/> Always <input type="checkbox"/> Sometimes <input type="checkbox"/> Only once <input type="checkbox"/> Does not come on ● When / how long does it come on? :		
Ignition key position	<input type="checkbox"/> LOCK <input type="checkbox"/> ACC <input type="checkbox"/> ON (before starting engine) <input type="checkbox"/> START <input type="checkbox"/> On after starting (Engine is running) <input type="checkbox"/> On after starting (Engine is stop)		
Timing	<input type="checkbox"/> Immediately after ignition is ON. <input type="checkbox"/> Immediately after ignition starts.		
	<input type="checkbox"/> When advancing	km/h to	km/h
		MPH to	MPH
	<input type="checkbox"/> While traveling at a constant speed	km/h	MPH
	<input type="checkbox"/> When decelerating	km/h to	km/h
		MPH to	MPH
	<input type="checkbox"/> When turning to right	Steering angle :	deg
		Steering time :	sec
	<input type="checkbox"/> When turning to left	Steering angle :	deg
		Steering time :	sec
<input type="checkbox"/> When moving other electrical parts	● Parts name : ● Operating condition :		

### 2. SYMPTOMS

ABS operating condition	<input type="checkbox"/> Performs no work.		
	<input type="checkbox"/> Operates only when abruptly applying brakes.	Vehicle speed :	km/h
			MPH
	● How to step on brake pedal :		
	a) Operating time :		sec
	b) Operating noise : <input type="checkbox"/> Produce / <input type="checkbox"/> Does not produce		
	● What kind of noise?	<input type="checkbox"/> Knock <input type="checkbox"/> Gong gong <input type="checkbox"/> Bong <input type="checkbox"/> Buzz <input type="checkbox"/> Gong gong buzz <input type="checkbox"/> Others :	
	c) Reaction force of brake pedal		
	<input type="checkbox"/> Stick <input type="checkbox"/> Press down once with a clunk <input type="checkbox"/> Press and released <input type="checkbox"/> Others :		

Behavior of vehicle	a) Directional stability cannot be obtained or steering arm refuses to work when applying brakes : <input type="checkbox"/> Yes / <input type="checkbox"/> No	
	● When :	<input type="checkbox"/> Vehicle turns to right <input type="checkbox"/> Vehicle turns to left <input type="checkbox"/> Spins <input type="checkbox"/> Others :
	b) Directional stability cannot be obtained or steering arm refuses to work when accelerating : <input type="checkbox"/> Yes / <input type="checkbox"/> No	
	● When :	<input type="checkbox"/> Vehicle turns to right <input type="checkbox"/> Vehicle turns to left <input type="checkbox"/> Spins <input type="checkbox"/> Others :
	c) Brakes are out of order : <input type="checkbox"/> Yes / <input type="checkbox"/> No	
	● What :	<input type="checkbox"/> Braking distance is long <input type="checkbox"/> Brakes lock or drag <input type="checkbox"/> Pedal stroke is long <input type="checkbox"/> Pedal sticks <input type="checkbox"/> Others :
	d) Poor acceleration : <input type="checkbox"/> Yes / <input type="checkbox"/> No	
	● What :	<input type="checkbox"/> Fails to accelerate <input type="checkbox"/> Engine stalls <input type="checkbox"/> Others :
	e) Occurrence of vibration : <input type="checkbox"/> Yes / <input type="checkbox"/> No	
	● Where ● What kind :	
f) Occurrence of abnormal noise : <input type="checkbox"/> Yes / <input type="checkbox"/> No		
● Where ● What kind :		
g) Occurrence of other phenomena : <input type="checkbox"/> Yes / <input type="checkbox"/> No		
● What kind :		

**3. CONDITIONS UNDER WHICH TROUBLE OCCURS**

Environment	a) Weather	<input type="checkbox"/> Fine <input type="checkbox"/> Cloudy <input type="checkbox"/> Rainy <input type="checkbox"/> Snowy <input type="checkbox"/> Various/Others :
	b) Ambient temperature	°F (°C)
	c) Road	<input type="checkbox"/> Urban area <input type="checkbox"/> Suburbs <input type="checkbox"/> Highway <input type="checkbox"/> General road <input type="checkbox"/> Ascending slope <input type="checkbox"/> Descending slope <input type="checkbox"/> Paved road <input type="checkbox"/> Gravel road <input type="checkbox"/> Muddy road <input type="checkbox"/> Sandy place <input type="checkbox"/> Others :
	d) Road surface	<input type="checkbox"/> Dry <input type="checkbox"/> Wet <input type="checkbox"/> New-fallen snow <input type="checkbox"/> Compressed snow <input type="checkbox"/> Frozen slope <input type="checkbox"/> Others :

## 6. Diagnostics Chart for On-board Diagnosis System

Condition	a) Brakes	Deceleration :	g	
		<input type="checkbox"/> Continuous / <input type="checkbox"/> Intermittent		
	b) Accelerator	Acceleration :	g	
		<input type="checkbox"/> Continuous / <input type="checkbox"/> Intermittent		
	c) Vehicle speed		km/h	MPH
			<input type="checkbox"/> Advancing	
			<input type="checkbox"/> Accelerating	
			<input type="checkbox"/> Reducing speed	
			<input type="checkbox"/> Low speed	
		<input type="checkbox"/> Turning		
		<input type="checkbox"/> Others :		
	d) Tire inflation pressure	Front RH tire :		kPa
		Front LH tire :		kPa
		Rear RH tire :		kPa
		Rear LH tire :		kPa
	e) Degree of wear	Front RH tire :		
		Front LH tire :		
		Rear RH tire :		
		Rear LH tire :		
	f) Genuine parts are used. :	<input type="checkbox"/> Yes / <input type="checkbox"/> No		
g) Chain is passed around tires. :	<input type="checkbox"/> Yes / <input type="checkbox"/> No			
h) T tire is used. :	<input type="checkbox"/> Yes / <input type="checkbox"/> No			
i) Condition of suspension alignment :				
j) Loading state :				
k) Repair parts are used. :	<input type="checkbox"/> Yes / <input type="checkbox"/> No			
● What :				
l) Others :				

**C: INSPECTION MODE**

Reproduce the condition under which the problem has occurred as much as possible.  
 Drive the vehicle at a speed more than 40 km/h (25 MPH) for at least one minute.

**D: TROUBLE CODES**

When on-board diagnosis of the ABS control module detects a problem, the information (up to a maximum of three) will be stored in the EEPROM as a trouble code. When there are more than three, the most recent three will be stored. (Stored codes will stay in memory until they are cleared.)

**1. CALLING UP A TROUBLE CODE**

1) Take out diagnosis connector from side of driver's seat heater unit.

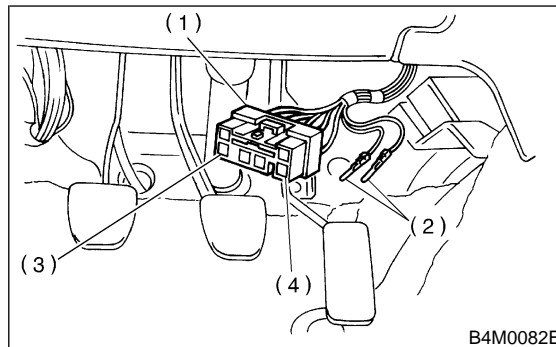

- (1) Diagnosis connector
- (2) Diagnosis terminals
- (3) 3 terminal
- (4) 6 terminal

- 2) Turn ignition switch OFF.
- 3) Connect diagnosis connector terminal 6 to diagnosis terminal.
- 4) Turn ignition switch ON.
- 5) ABS warning light is set in the diagnostic mode and blinks to identify trouble code.

6) After the start code (11) is shown, the trouble codes will be shown in order of the last information first. These repeat for a maximum of 3 minutes.

**NOTE:**

When there are no trouble codes in memory, only the start code (11) is shown.

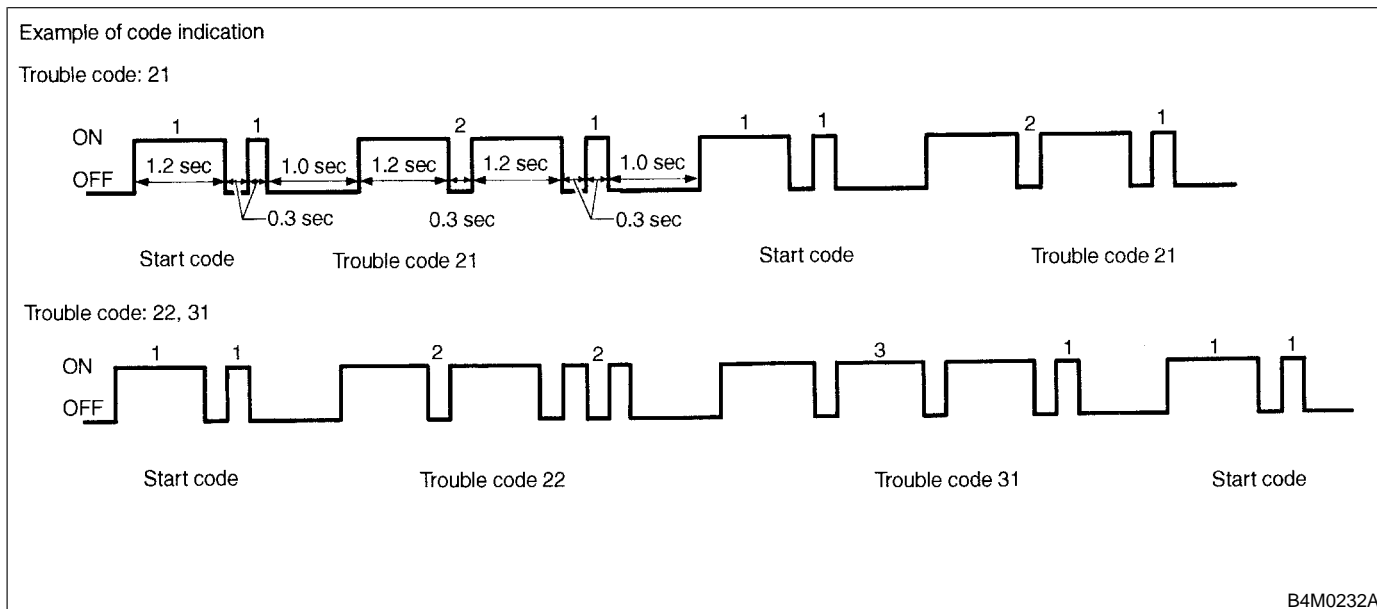

**2. CLEARING MEMORY**

1) After calling up a trouble code, disconnect diagnosis connector terminal 6 from diagnosis terminal.

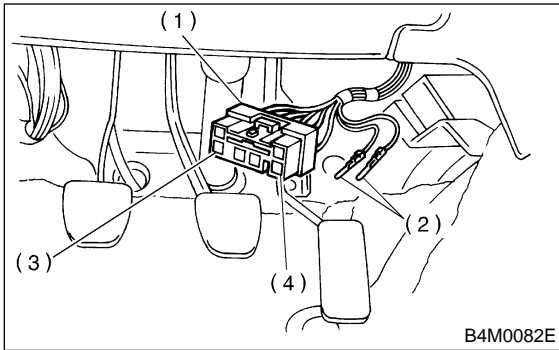

- (1) Diagnosis connector
- (2) Diagnosis terminals
- (3) 3 terminal
- (4) 6 terminal

2) Repeat 3 times within approx. 12 seconds; connecting and disconnecting terminal 6 and diagnosis terminal for at least 0.2 seconds each time.

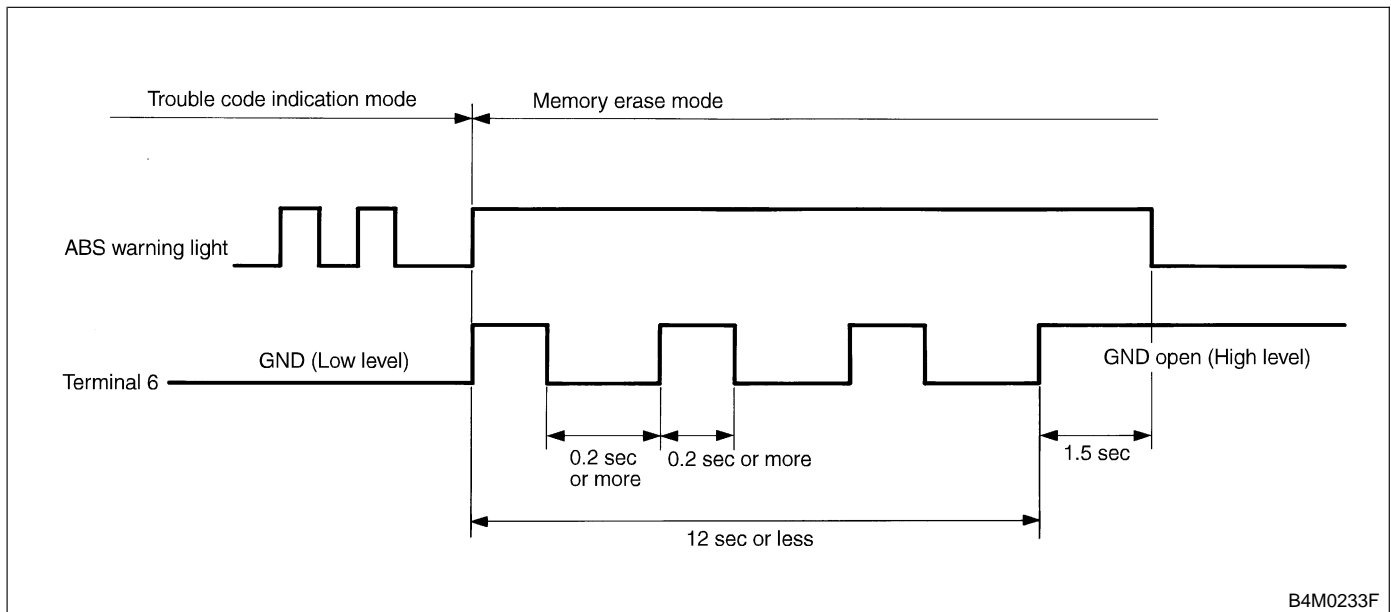

**NOTE:**

After diagnostics is completed, make sure to clear memory. Make sure only start code (11) is shown after memory is cleared.



**MEMO:**

# 7. Diagnostics Chart for ABS Warning Light Circuit and Diagnosis Circuit Failure

## A: ABS WARNING LIGHT DOES NOT COME ON.

### DIAGNOSIS:

- ABS warning light circuit is open or shorted.

### TROUBLE SYMPTOM:

- When ignition switch is turned ON (engine OFF), ABS warning light does not come on.

### WIRING DIAGRAM:

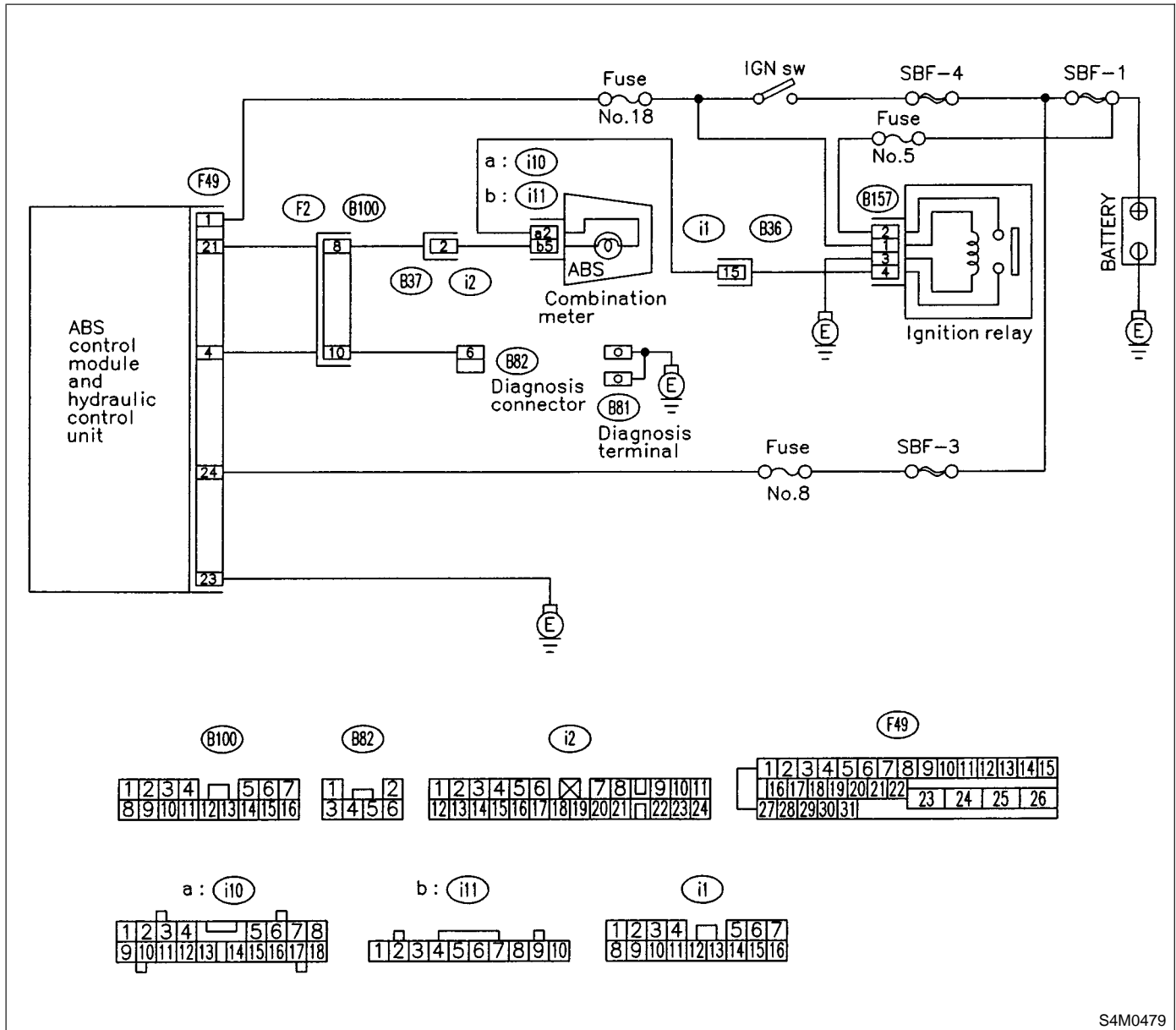

**7A1 : CHECK IF OTHER WARNING LIGHTS TURN ON.**

Turn ignition switch to ON (engine OFF).

- CHECK** : *Do other warning lights turn on?*
- YES** : Go to step **7A2**.
- NO** : Repair combination meter. <Ref. to 6-2 [W8A0].>

**7A2 : CHECK ABS WARNING LIGHT BULB.**

- 1) Turn ignition switch to OFF.
- 2) Remove combination meter. <Ref. to 6-2 [W8A0].>
- 3) Remove ABS warning light bulb from combination meter.

- CHECK** : *Is ABS warning light bulb OK?*
- YES** : Go to step **7A3**.
- NO** : Replace ABS warning light bulb. <Ref. to 6-2 [W8B0].>

**7A3 : CHECK BATTERY SHORT OF ABS WARNING LIGHT HARNESS.**

- 1) Disconnect connector (B100) from connector (F2).
- 2) Measure voltage between connector (B100) and chassis ground.

**Connector & terminal**  
**(B100) No. 8 (+) — Chassis ground (-):**

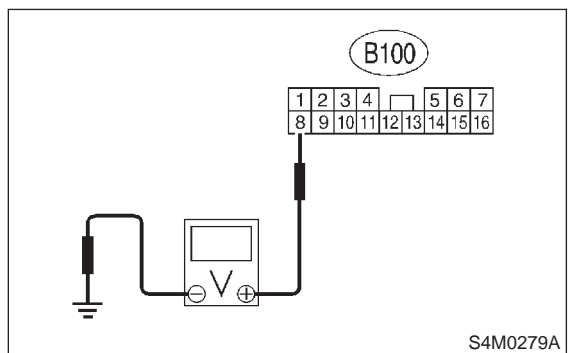

- CHECK** : *Is the voltage less than 3 V?*
- YES** : Go to step **7A4**.
- NO** : Repair warning light harness.

**7A4 : CHECK BATTERY SHORT OF ABS WARNING LIGHT HARNESS.**

- 1) Turn ignition switch to ON.
- 2) Measure voltage between connector (B100) and chassis ground.

**Connector & terminal**  
**(B100) No. 8 (+) — Chassis ground (-):**

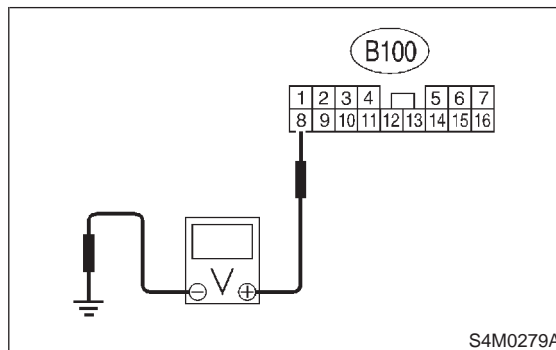

- CHECK** : *Is voltage less than 3 V?*
- YES** : Go to step **7A5**.
- NO** : Repair warning light harness.

**7A5 : CHECK WIRING HARNESS.**

- 1) Turn ignition switch to OFF.
- 2) Install ABS warning light bulb from combination meter.
- 3) Install combination meter.
- 4) Turn ignition switch to ON.
- 5) Measure voltage between connector (B100) and chassis ground.

**Connector & terminal**  
**(B100) No. 8 (+) — Chassis ground (-):**

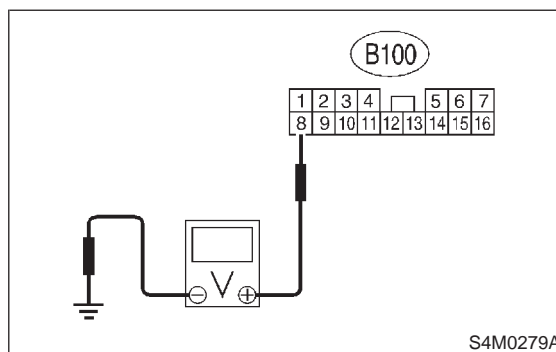

- CHECK** : *Is voltage between 10 and 15 V?*
- YES** : Go to step **7A6**.
- NO** : Repair wiring harness.

**7A6 : CHECK BATTERY SHORT OF ABS WARNING LIGHT HARNESS.**

- 1) Turn ignition switch to OFF.
- 2) Measure voltage between connector (F2) and chassis ground.

**Connector & terminal**

**(F2) No. 8 (+) — Chassis ground (-):**

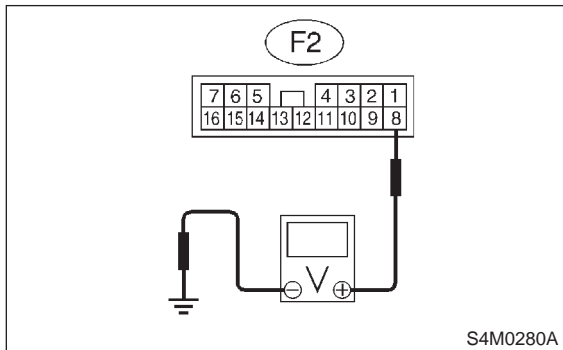

- CHECK** : Is the voltage less than 3 V?
- YES** : Go to step 7A7.
- NO** : Repair wiring harness.

**7A7 : CHECK BATTERY SHORT OF ABS WARNING LIGHT HARNESS.**

- 1) Turn ignition switch to ON.
- 2) Measure voltage between connector (F2) and chassis ground.

**Connector & terminal**

**(F2) No. 8 (+) — Chassis ground (-):**

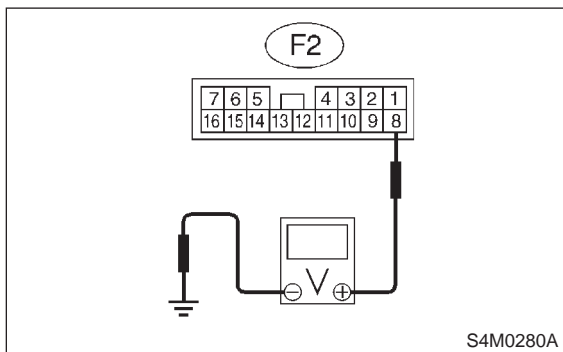

- CHECK** : Is voltage less than 3 V?
- YES** : Go to step 7A8.
- NO** : Repair wiring harness.

**7A8 : CHECK GROUND CIRCUIT OF ABSCM&H/U.**

Measure resistance between ABSCM&H/U and chassis ground.

**Connector & terminal**

**(F49) No. 23 — Chassis ground:**

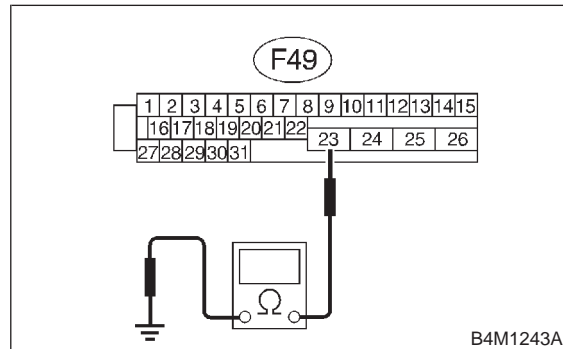

- CHECK** : Is the resistance less than 0.5 Ω?
- YES** : Go to step 7A9.
- NO** : Repair ABSCM&H/U ground harness.

**7A9 : CHECK WIRING HARNESS.**

Measure resistance between connector (F2) and chassis ground.

**Connector & terminal**

**(F2) No. 8 — Chassis ground:**

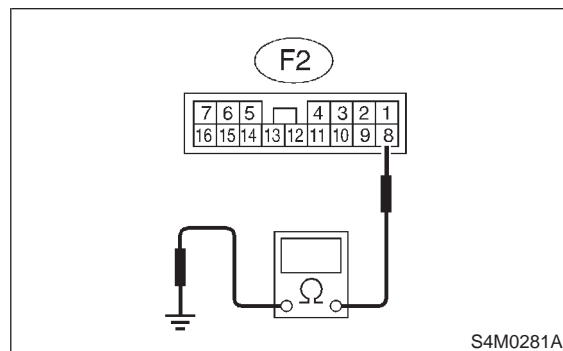

- CHECK** : Is the resistance less than 0.5 Ω?
- YES** : Go to step 7A10.
- NO** : Repair harness/connector.

**7A10 : CHECK POOR CONTACT IN CONNECTORS.**

Turn ignition switch to OFF.

**CHECK** : *Is there poor contact in connectors between combination meter and ABSCM&H/U? <Ref. to FOREWORD [W3C1].>*

**YES** : Repair connector.

**NO** : Replace ABSCM&H/U. <Ref. to 4-4 [W14A0].>

**B: ABS WARNING LIGHT DOES NOT GO OFF.**

**DIAGNOSIS:**

- ABS warning light circuit is open or shorted.

**TROUBLE SYMPTOM:**

- When starting the engine and while ABS warning light is kept ON.

**WIRING DIAGRAM:**

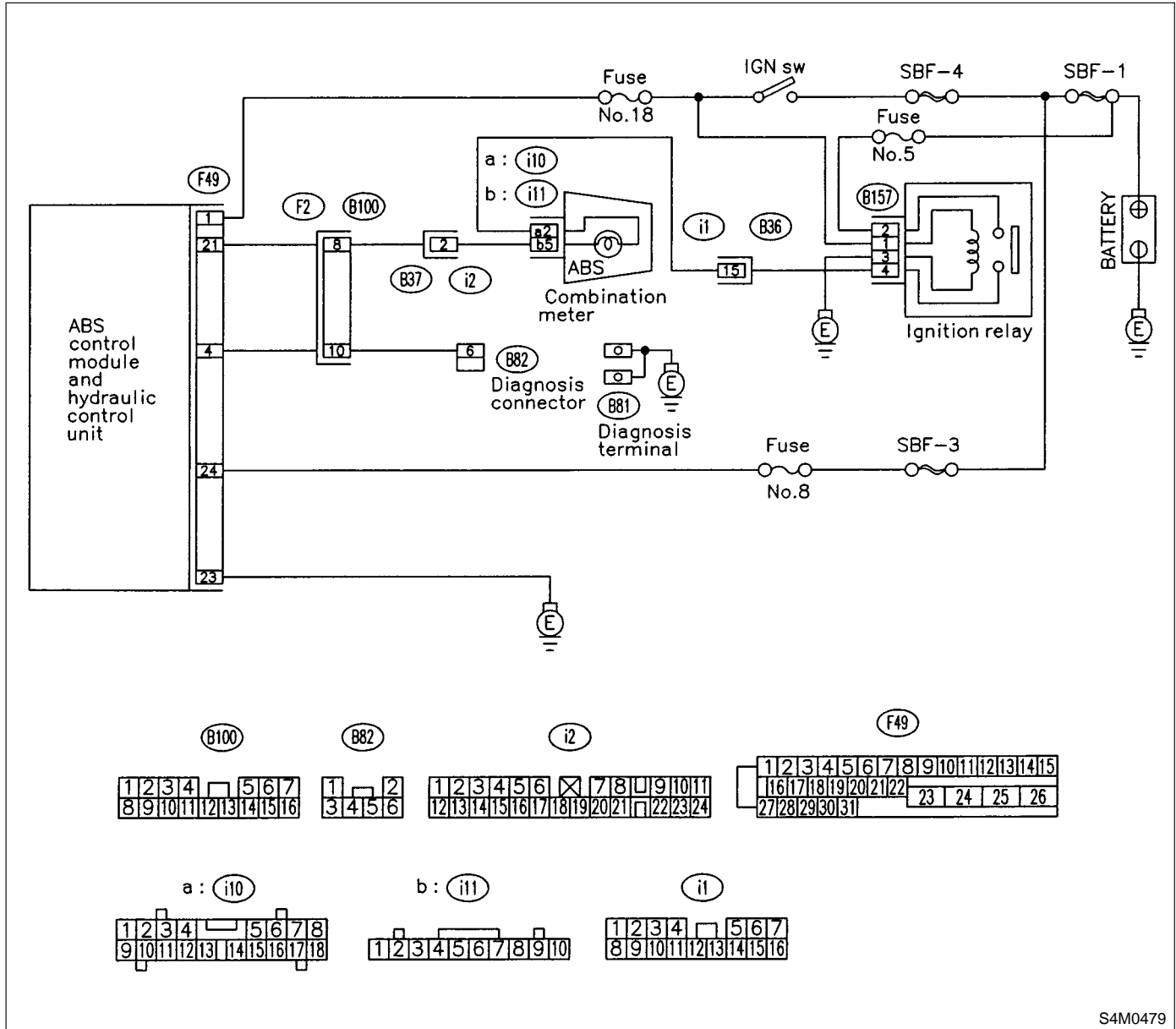

**7B1 : CHECK INSTALLATION OF ABSCM&H/U CONNECTOR.**

Turn ignition switch to OFF.

**CHECK** : *Is ABSCM&H/U connector inserted into ABSCM until the clamp locks onto it?*

**YES** : Go to step **7B2**.

**NO** : Insert ABSCM&H/U connector into ABSCM&H/U until the clamp locks onto it.

**7B2 : CHECK DIAGNOSIS TERMINAL.**

Measure resistance between diagnosis terminals (B81) and chassis ground.

**Terminals**

**Diagnosis terminal (A) — Chassis ground:**

**Diagnosis terminal (B) — Chassis ground:**

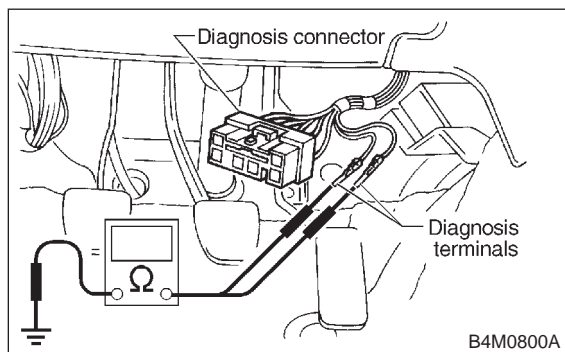

**CHECK** : *Is the resistance less than 0.5 Ω?*

**YES** : Go to step **7B3**.

**NO** : Repair diagnosis terminal harness.

**7B3 : CHECK DIAGNOSIS LINE.**

- 1) Turn ignition switch to OFF.
- 2) Connect diagnosis terminal (B81) to diagnosis connector (B82) No. 6.
- 3) Disconnect connector from ABSCM&H/U.
- 4) Measure resistance between ABSCM&H/U connector and chassis ground.

**Connector & terminal**

**(F49) No. 4 — Chassis ground:**

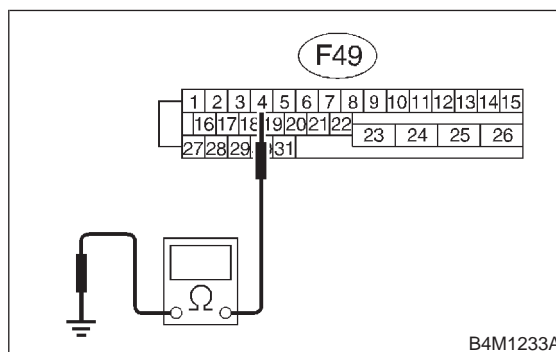

**CHECK** : *Is the resistance less than 0.5 Ω?*

**YES** : Go to step **7B4**.

**NO** : Repair harness connector between ABSCM&H/U and diagnosis connector.

**7B4 : CHECK GENERATOR.**

- 1) Start the engine.
- 2) Idle the engine.
- 3) Measure voltage between generator and chassis ground.

**Terminals**

**Generator B terminal (+) — Chassis ground (-):**

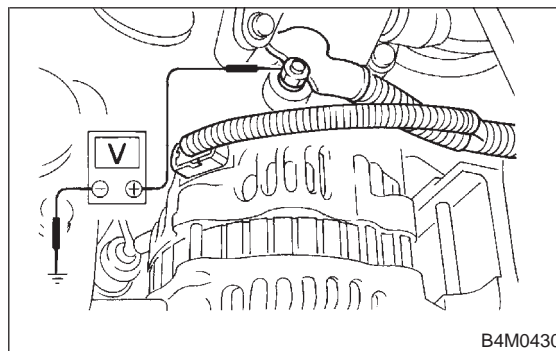

**CHECK** : *Is the voltage between 10 and 15 V?*

**YES** : Go to step **7B5**.

**NO** : Repair generator. <Ref. to 6-1 [W2A0].>

**7B5 : CHECK BATTERY TERMINAL.**

Turn ignition switch to OFF.

**CHECK** : *Is there poor contact at battery terminal?*

**YES** : Repair battery terminal.

**NO** : Go to step **7B6**.

**7B6 : CHECK POWER SUPPLY OF ABSCM.**

- 1) Disconnect connector from ABSCM&H/U.
- 2) Start engine.
- 3) Idle the engine.
- 4) Measure voltage between ABSCM&H/U connector and chassis ground.

**Connector & terminal**

**(F49) No. 1 (+) — Chassis ground (-):**

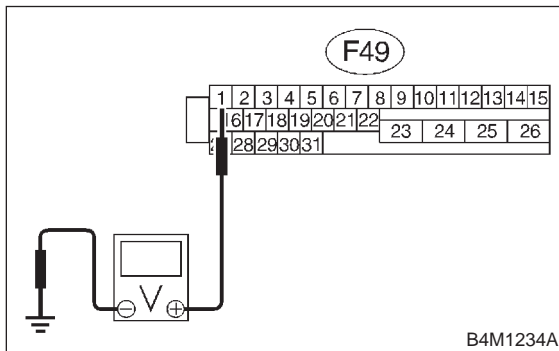

**CHECK** : *Is the voltage between 10 and 15 V?*

**YES** : Go to step **7B7**.

**NO** : Repair ABSCM&H/U power supply circuit.

**7B7 : CHECK WIRING HARNESS.**

- 1) Disconnect connector (F2) from connector (B100).
- 2) Turn ignition switch to ON.

**CHECK** : *Does the ABS warning light remain off?*

**YES** : Go to step **7B8**.

**NO** : Repair front wiring harness.

**7B8 : CHECK PROJECTION AT ABSCM&H/U.**

- 1) Turn ignition switch to OFF.
- 2) Check for broken projection at the ABSCM&H/U terminal.

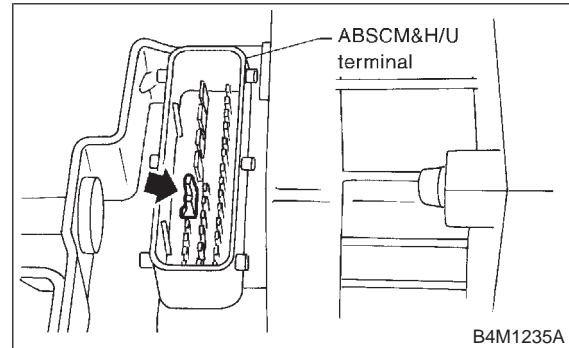

**CHECK** : *Are the projection broken?*

**YES** : Replace ABSCM&H/U. <Ref. to 4-4 [W14A0].>

**NO** : Go to step **7B9**.

**7B9 : CHECK ABSCM&H/U.**

Measure resistance between ABSCM&H/U terminals.

**Terminals**

**No. 21 — No. 23:**

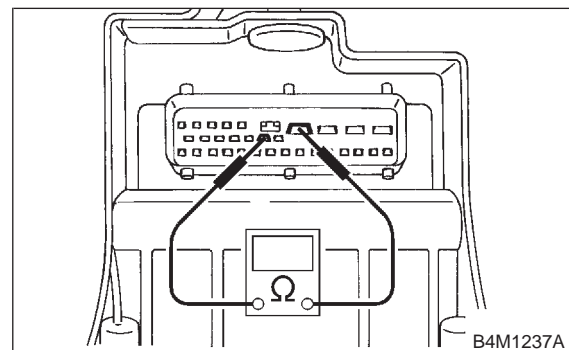

**CHECK** : *Is the resistance more than 1 MΩ?*

**YES** : Go to step **7B10**.

**NO** : Replace ABSCM&H/U. <Ref. to 4-4 [W14A0].>



**7B10 : CHECK WIRING HARNESS.**

Measure resistance between connector (F2) and chassis ground.

**Connector & terminal**

**(F2) No. 8 — Chassis ground:**

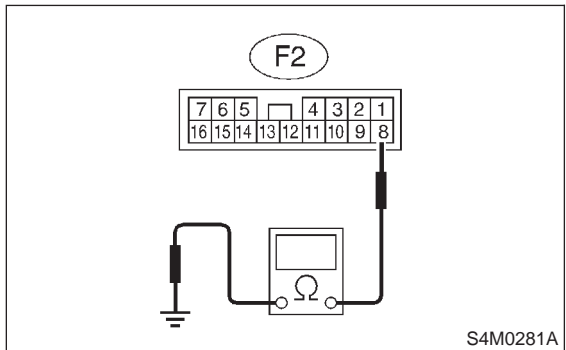

- CHECK** : *Is the resistance less than 0.5 Ω?*
- YES** : Go to step **7B11**.
- NO** : Repair harness.

**7B11 : CHECK WIRING HARNESS.**

- 1) Connect connector to ABSCM&H/U.
- 2) Measure resistance between connector (F2) and chassis ground.

**Connector & terminal**

**(F2) No. 8 — Chassis ground:**

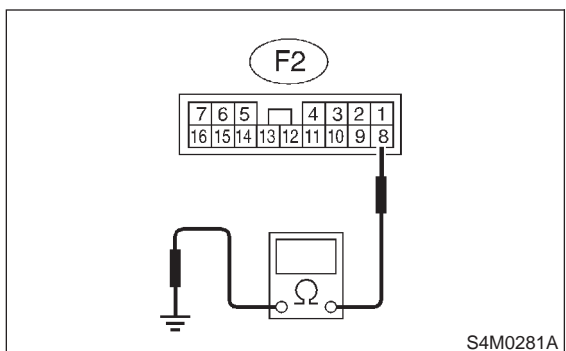

- CHECK** : *Is the resistance more than 1 MΩ?*
- YES** : Go to step **7B12**.
- NO** : Repair harness.

**7B12 : CHECK POOR CONTACT IN ABSCM&H/U CONNECTOR.**

- CHECK** : *Is there poor contact in ABSCM&H/U connector? <Ref. to FOREWORD [W3C1].>*
- YES** : Repair connector.
- NO** : Replace ABSCM&H/U. <Ref. to 4-4 [W14A0].>

**C: TROUBLE CODE DOES NOT APPEAR.**

**DIAGNOSIS:**

- Diagnosis circuit is open.

**TROUBLE SYMPTOM:**

- The ABS warning light turns on or off normally but the start code cannot be read out in the diagnostic mode.

**WIRING DIAGRAM:**

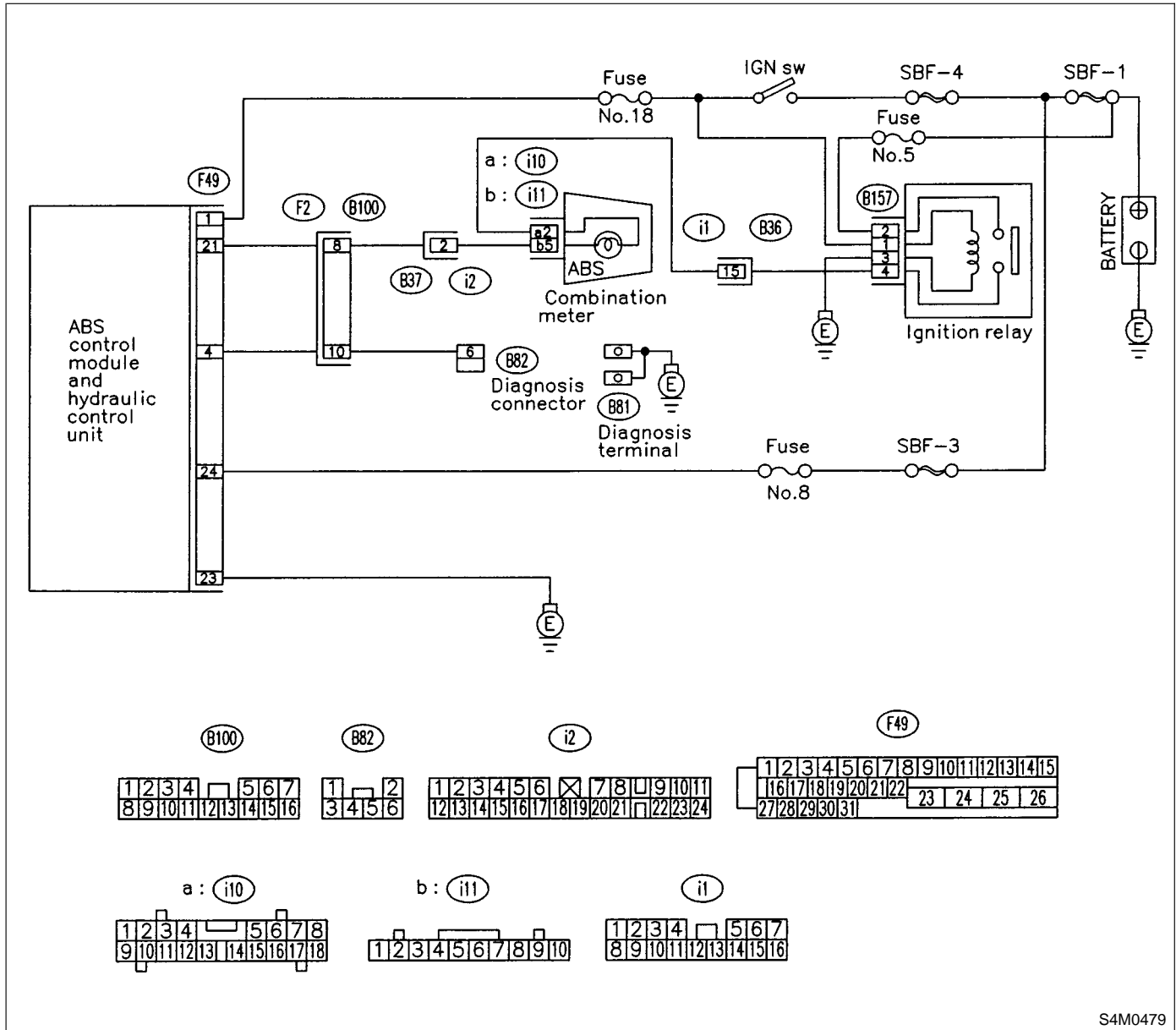

S4M0479

**7C1 : CHECK DIAGNOSIS TERMINAL.**

Measure resistance between diagnosis terminals (B81) and chassis ground.

**Terminals**

**Diagnosis terminal (A) — Chassis ground:**

**Diagnosis terminal (B) — Chassis ground:**

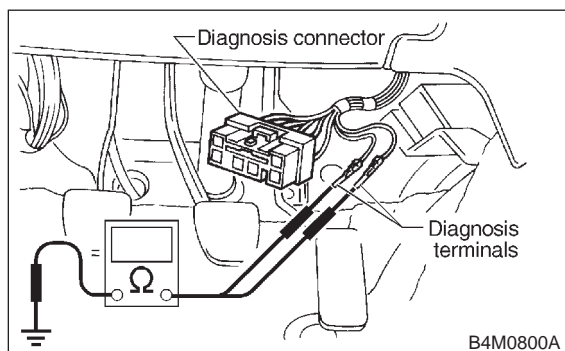

- CHECK** : *Is the resistance less than 0.5 Ω?*
- YES** : Go to step **7C2**.
- NO** : Repair diagnosis terminal harness.

**7C2 : CHECK DIAGNOSIS LINE.**

- 1) Turn ignition switch to OFF.
- 2) Connect diagnosis terminal (B81) to diagnosis connector (B82) No. 6.
- 3) Disconnect connector from ABSCM&H/U.
- 4) Measure resistance between ABSCM&H/U connector and chassis ground.

**Connector & terminal**

**(F49) No. 4 — Chassis ground:**

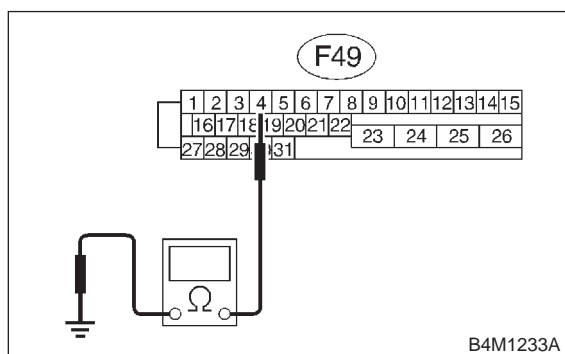

- CHECK** : *Is the resistance less than 0.5 Ω?*
- YES** : Go to step **7C3**.
- NO** : Repair harness connector between ABSCM&H/U and diagnosis connector.

**7C3 : CHECK POOR CONTACT IN ABSCM&H/U CONNECTOR.**

- CHECK** : *Is there poor contact in ABSCM&H/U connector? <Ref. to FOREWORD [W3C1].>*
- YES** : Repair connector.
- NO** : Replace ABSCM&H/U. <Ref. to 4-4 [W14A0].>

**MEMO:**

## 8. Diagnostics Chart with Trouble Code by ABS Warning Light

### A: LIST OF TROUBLE CODE

Trouble code	Contents of diagnosis	Ref. to
11	Start code <ul style="list-style-type: none"> <li>● Trouble code is shown after start code.</li> <li>● Only start code is shown in normal condition.</li> </ul>	—
21	Abnormal ABS sensor (Open circuit or input voltage too high)	Front right ABS sensor
23		Front left ABS sensor
25		Rear right ABS sensor
27		Rear left ABS sensor
22	Abnormal ABS sensor (Abnormal ABS sensor signal)	Front right ABS sensor
24		Front left ABS sensor
26		Rear right ABS sensor
28		Rear left ABS sensor
29		Any one of four
31		Front right inlet valve
32		Front right outlet valve
33	Abnormal solenoid valve circuit(s) in ABS control module and hydraulic unit	Front left inlet valve
34		Front left outlet valve
35		Rear right inlet valve
36		Rear right outlet valve
37		Rear left inlet valve
38		Rear left outlet valve
41	Abnormal ABS control module	<Ref. to 4-4 [T8S0].>
42	Source voltage is abnormal.	<Ref. to 4-4 [T8T0].>
44	A combination of AT control abnormal	<Ref. to 4-4 [T8U0].>
51	Abnormal valve relay	<Ref. to 4-4 [T8V0].>
52	Abnormal motor and/or motor relay	<Ref. to 4-4 [T8W0].>
54	Abnormal stop light switch	<Ref. to 4-4 [T8X0].>
56	Abnormal G sensor output voltage	<Ref. to 4-4 [T8Y0].>

**B: TROUBLE CODE 21 (FRONT RH)**

**C: TROUBLE CODE 23 (FRONT LH)**

**D: TROUBLE CODE 25 (REAR RH)**

**E: TROUBLE CODE 27 (REAR LH)**

**— ABNORMAL ABS SENSOR (OPEN CIRCUIT OR INPUT VOLTAGE TOO HIGH) —**

**DIAGNOSIS:**

- Faulty ABS sensor (Broken wire, input voltage too high)
- Faulty harness connector

**TROUBLE SYMPTOM:**

- ABS does not operate.

**WIRING DIAGRAM:**

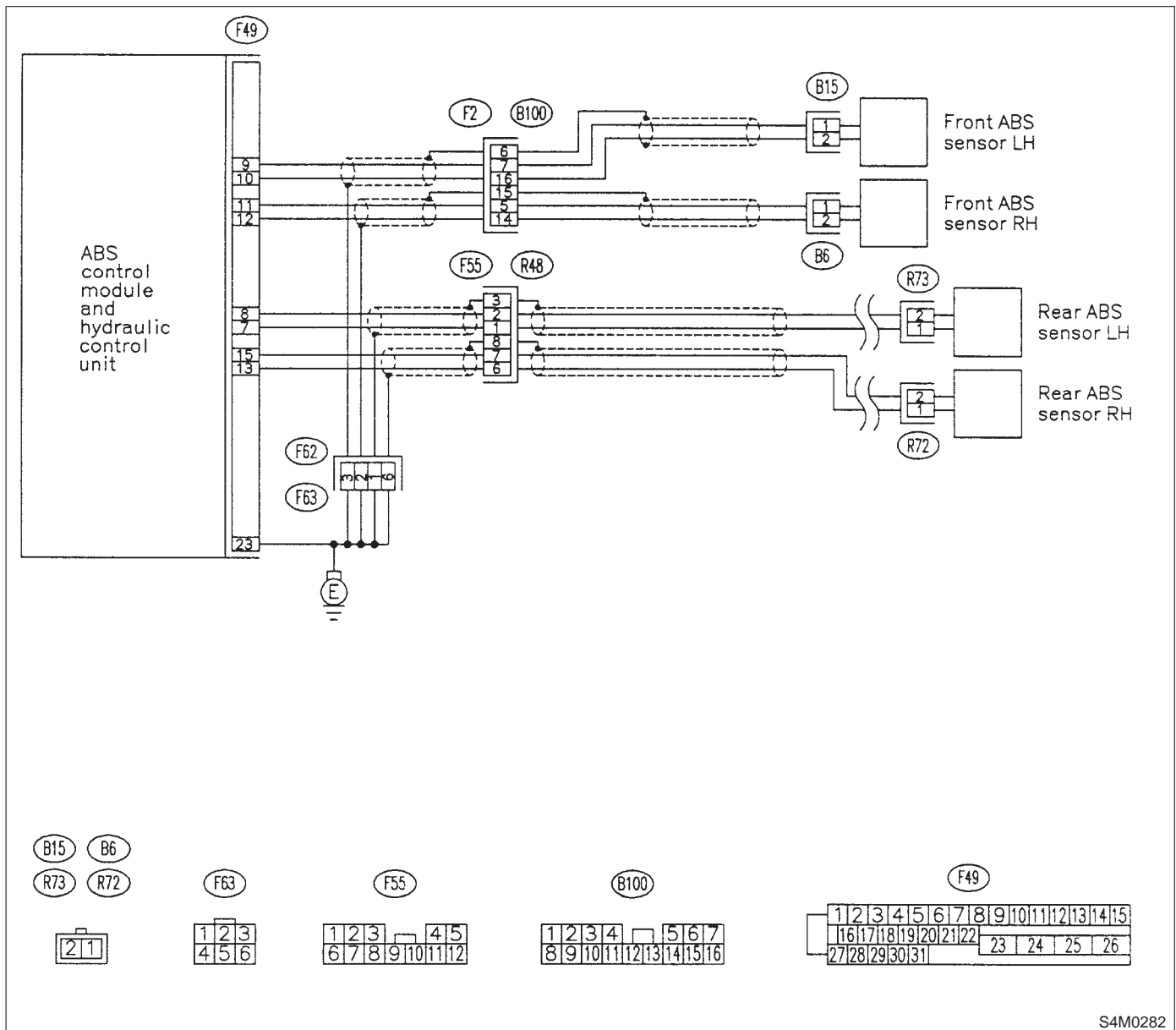

**8E1 : CHECK FRONT ABS SENSOR.**

- 1) Turn ignition switch to OFF.
- 2) Disconnect connector from front ABS sensor.
- 3) Measure resistance of front ABS sensor connector terminals.

**Terminals**

**RH No. 1 — No. 2:**

**LH No. 1 — No. 2:**

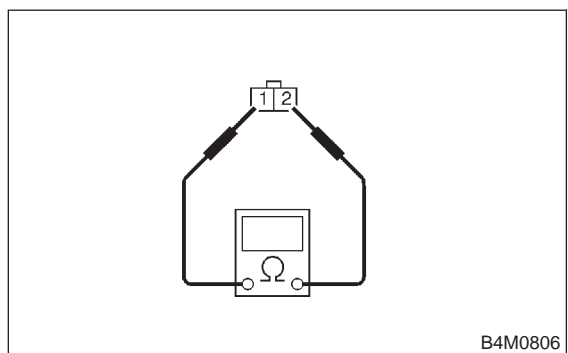

**CHECK** : *Is the resistance between 1.0 and 1.5 kΩ?*

**YES** : Go to step 8E2.

**NO** : Replace front ABS sensor.

**8E2 : CHECK REAR ABS SENSOR.**

- 1) Turn ignition switch to OFF.
- 2) Disconnect connector from rear ABS sensor.
- 3) Measure resistance of rear ABS sensor connector terminals.

**Terminals**

**RH No. 1 — No. 2:**

**LH No. 1 — No. 2:**

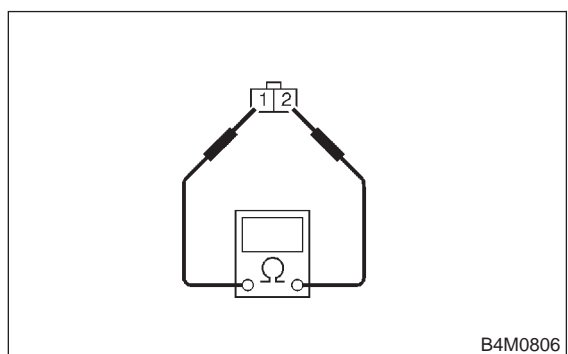

**CHECK** : *Is the resistance between 0.8 and 1.2 kΩ?*

**YES** : Go to step 8E3.

**NO** : Replace rear ABS sensor.

**8E3 : CHECK BATTERY SHORT OF ABS SENSOR.**

- 1) Disconnect connector from ABSCM&H/U.
- 2) Measure voltage between ABS sensor and chassis ground.

**Terminals**

**Front RH No. 1 (+) — Chassis ground (-):**

**Front LH No. 1 (+) — Chassis ground (-):**

**Rear RH No. 1 (+) — Chassis ground (-):**

**Rear LH No. 1 (+) — Chassis ground (-):**

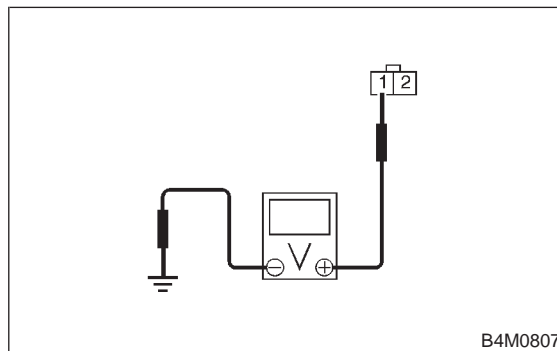

**CHECK** : *Is the voltage less than 1 V?*

**YES** : Go to step 8E4.

**NO** : Replace ABS sensor.

**8E4 : CHECK BATTERY SHORT OF ABS SENSOR.**

- 1) Turn ignition switch to ON.
- 2) Measure voltage between ABS sensor and chassis ground.

**Terminals**

**Front RH No. 1 (+) — Chassis ground (-):**

**Front LH No. 1 (+) — Chassis ground (-):**

**Rear RH No. 1 (+) — Chassis ground (-):**

**Rear LH No. 1 (+) — Chassis ground (-):**

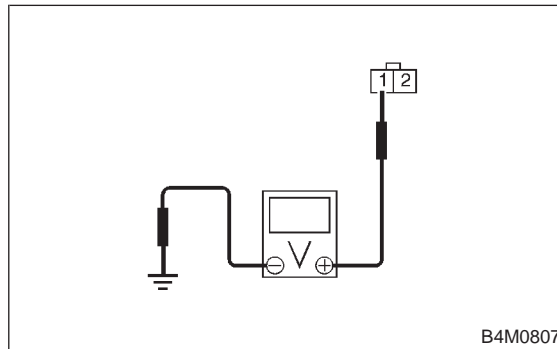

**CHECK** : *Is the voltage less than 1 V?*

**YES** : Go to step 8E5.

**NO** : Replace ABS sensor.

**8E5 : CHECK TROUBLE CODE.**

- CHECK** : *Is the trouble code 21 and/or 23?*
- YES** : Go to step **8E6**.
- NO** : Go to step **8E7**.

**8E6 : CHECK HARNESS/CONNECTOR BETWEEN ABSCM&H/U AND ABS SENSOR.**

- 1) Turn ignition switch to OFF.
- 2) Connect connector to ABS sensor.
- 3) Measure resistance between ABSCM&H/U connector terminals.

**Connector & terminal**

**Trouble code 21 / (F49) No. 11 — No. 12:**  
**Trouble code 23 / (F49) No. 9 — No. 10:**

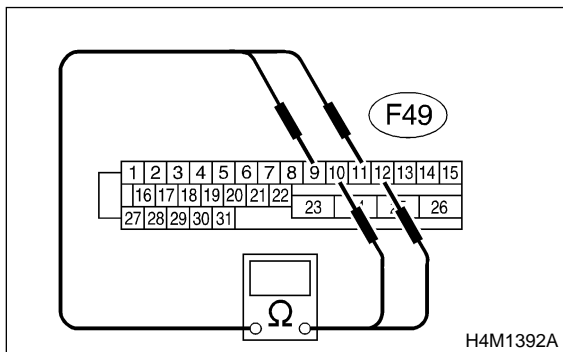

- CHECK** : *Is the resistance between 1.0 and 1.5 kΩ?*
- YES** : Go to step **8E8**.
- NO** : Repair harness/connector between ABSCM&H/U and ABS sensor.

**8E7 : CHECK HARNESS/CONNECTOR BETWEEN ABSCM&H/U AND ABS SENSOR.**

- 1) Turn ignition switch to OFF.
- 2) Connect connector to ABS sensor.
- 3) Measure resistance between ABSCM&H/U connector terminals.

**Connector & terminal**

**Trouble code 25 / (F49) No. 13 — No. 15:**  
**Trouble code 27 / (F49) No. 7 — No. 8:**

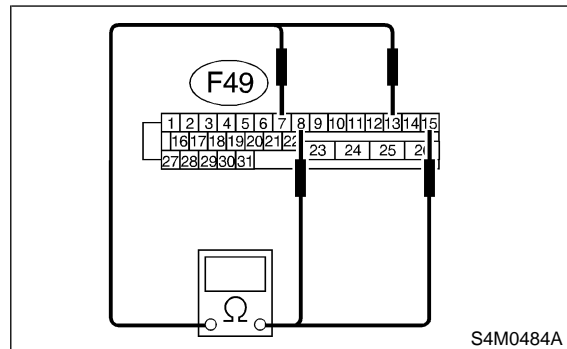

- CHECK** : *Is the resistance between 0.8 and 1.2 kΩ?*
- YES** : Go to step **8E8**.
- NO** : Repair harness/connector between ABSCM&H/U and ABS sensor.



**8E8 : CHECK BATTERY SHORT OF HARNESS.**

Measure voltage between ABSCM&H/U connector and chassis ground.

**Connector & terminal**

- Trouble code 21 / (F49) No. 11 (+) — Chassis ground (-):
- Trouble code 23 / (F49) No. 9 (+) — Chassis ground (-):
- Trouble code 25 / (F49) No. 13 (+) — Chassis ground (-):
- Trouble code 27 / (F49) No. 7 (+) — Chassis ground (-):

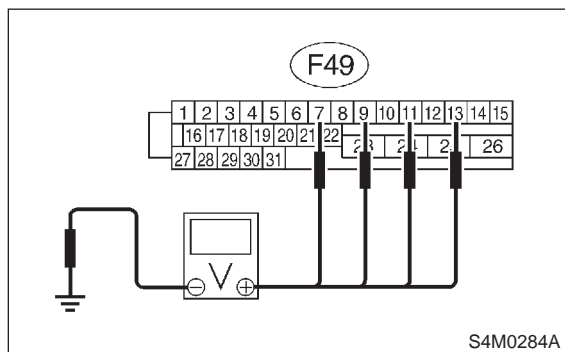

- CHECK** : *Is the voltage less than 1 V?*
- YES** : Go to step **8E9**.
- NO** : Repair harness between ABSCM&H/U and ABS sensor.

**8E9 : CHECK BATTERY SHORT OF HARNESS.**

- 1) Turn ignition switch to ON.
- 2) Measure voltage between ABSCM&H/U connector and chassis ground.

**Connector & terminal**

- Trouble code 21 / (F49) No. 11 (+) — Chassis ground (-):
- Trouble code 23 / (F49) No. 9 (+) — Chassis ground (-):
- Trouble code 25 / (F49) No. 13 (+) — Chassis ground (-):
- Trouble code 27 / (F49) No. 7 (+) — Chassis ground (-):

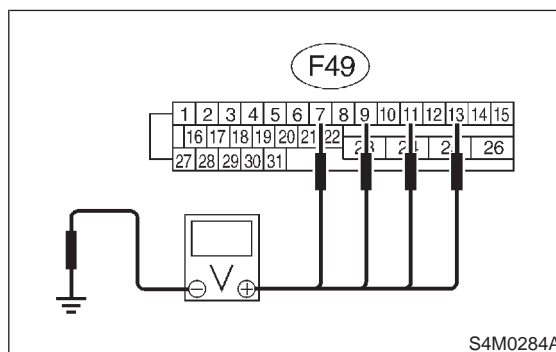

- CHECK** : *Is the voltage less than 1 V?*
- YES** : Go to step **8E10**.
- NO** : Repair harness between ABSCM&H/U and ABS sensor.

**8E10 : CHECK INSTALLATION OF ABS SENSOR.**

**Tightening torque:**

**32±10 N·m (3.3±1.0 kg·m, 24±7 ft·lb)**

- CHECK** : *Are the ABS sensor installation bolts tightened securely?*
- YES** : Go to step **8E11**.
- NO** : Tighten ABS sensor installation bolts securely.

**8E11 : CHECK TROUBLE CODE.**

- CHECK** : *Is the trouble code 25 and/or 27?*
- YES** : Go to step **8E12**.
- NO** : Go to step **8E13**.

**8E12 : CHECK INSTALLATION OF REAR TONE WHEEL.**

**Tightening torque:**

**13±3 N·m (1.3±0.3 kg·m, 9±2.2 ft·lb)**

**CHECK** : Are the rear tone wheel installation bolts tightened securely?

**YES** : Go to step 8E13.

**NO** : Tighten rear tone wheel installation bolts securely.

**8E13 : CHECK ABS SENSOR GAP.**

Measure tone wheel-to-pole piece gap over entire perimeter of the wheel. <Ref. to 4-4 [W13C0].>

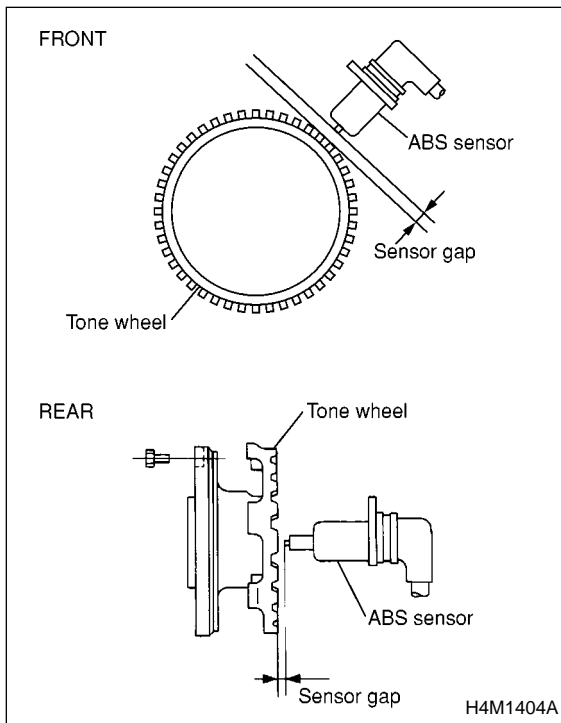

Specifications	Front wheel	Rear wheel
	0.3 — 0.8 mm (0.012 — 0.031 in)	0.7 — 1.2 mm (0.028 — 0.047 in)

**CHECK** : Is the gap within the specifications?

**YES** : Go to step 8E14.

**NO** : Adjust the gap.

**NOTE:**

Adjust the gap using spacers (Part No. 26755AA000). If spacers cannot correct the gap, replace worn sensor or worn tone wheel.

**8E14 : CHECK HUB RUNOUT.**

Measure hub runout.

**CHECK** : Is the runout less than 0.05 mm (0.0020 in)?

**YES** : Go to step 8E15.

**NO** : Repair hub.

**8E15 : CHECK GROUND SHORT OF ABS SENSOR.**

- 1) Turn ignition switch to OFF.
- 2) Measure resistance between ABS sensor and chassis ground.

**Terminals**

**Front RH No. 1 — Chassis ground:**

**Front LH No. 1 — Chassis ground:**

**Rear RH No. 1 — Chassis ground:**

**Rear LH No. 1 — Chassis ground:**

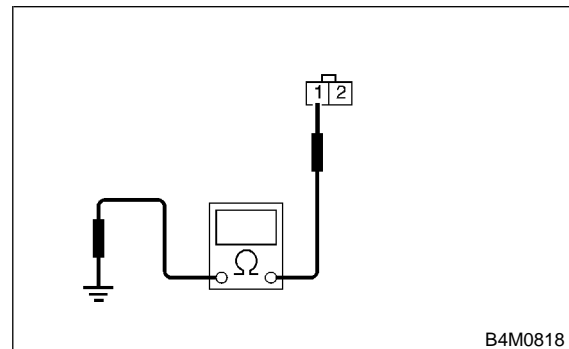

B4M0818

**CHECK** : Is the resistance more than 1 MΩ?

**YES** : Go to step 8E16.

**NO** : Replace ABS sensor and ABSCM&H/U.

**8E16 : CHECK GROUND SHORT OF HARNESS.**

- 1) Turn ignition switch to OFF.
- 2) Connect connector to ABS sensor.
- 3) Measure resistance between ABSCM&H/U connector terminal and chassis ground.

**Connector & terminal**

**Trouble code 21 / (F49) No. 11 — Chassis ground:**

**Trouble code 23 / (F49) No. 9 — Chassis ground:**

**Trouble code 25 / (F49) No. 13 — Chassis ground:**

**Trouble code 27 / (F49) No. 7 — Chassis ground:**

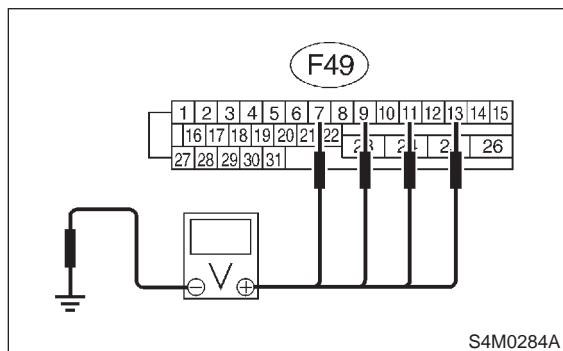

- CHECK** : *Is the resistance more than 1 MΩ?*
- YES** : Go to step **8E17**.
- NO** : Repair harness between ABSCM&H/U and ABS sensor. Replace ABSCM&H/U. <Ref. to 4-4 [W14A0].>

**8E17 : CHECK POOR CONTACT IN CONNECTORS.**

- CHECK** : *Is there poor contact in connectors between ABSCM&H/U and ABS sensor? <Ref. to FOREWORD [W3C1].>*
- YES** : Repair connector.
- NO** : Go to step **8E18**.

**8E18 : CHECK ABSCM&H/U.**

- 1) Connect all connectors.
- 2) Erase the memory.
- 3) Perform inspection mode.
- 4) Read out the trouble code.

- CHECK** : *Is the same trouble code as in the current diagnosis still being output?*
- YES** : Replace ABSCM&H/U. <Ref. to 4-4 [W14A0].>
- NO** : Go to step **8E19**.

**8E19 : CHECK ANY OTHER TROUBLE CODES APPEARANCE.**

- CHECK** : *Are other trouble codes being output?*
- YES** : Proceed with the diagnosis corresponding to the trouble code.
- NO** : A temporary poor contact.

**NOTE:**

Check harness and connectors between ABSCM&H/U and ABS sensor.

**F: TROUBLE CODE 22 (FRONT RH)**

**G: TROUBLE CODE 24 (FRONT LH)**

**H: TROUBLE CODE 26 (REAR RH)**

**I: TROUBLE CODE 28 (REAR LH)**

**— ABNORMAL ABS SENSOR (ABNORMAL ABS SENSOR SIGNAL) —**

**DIAGNOSIS:**

- Faulty ABS sensor signal (noise, irregular signal, etc.)
- Faulty harness/connector

**TROUBLE SYMPTOM:**

- ABS does not operate.

**WIRING DIAGRAM:**

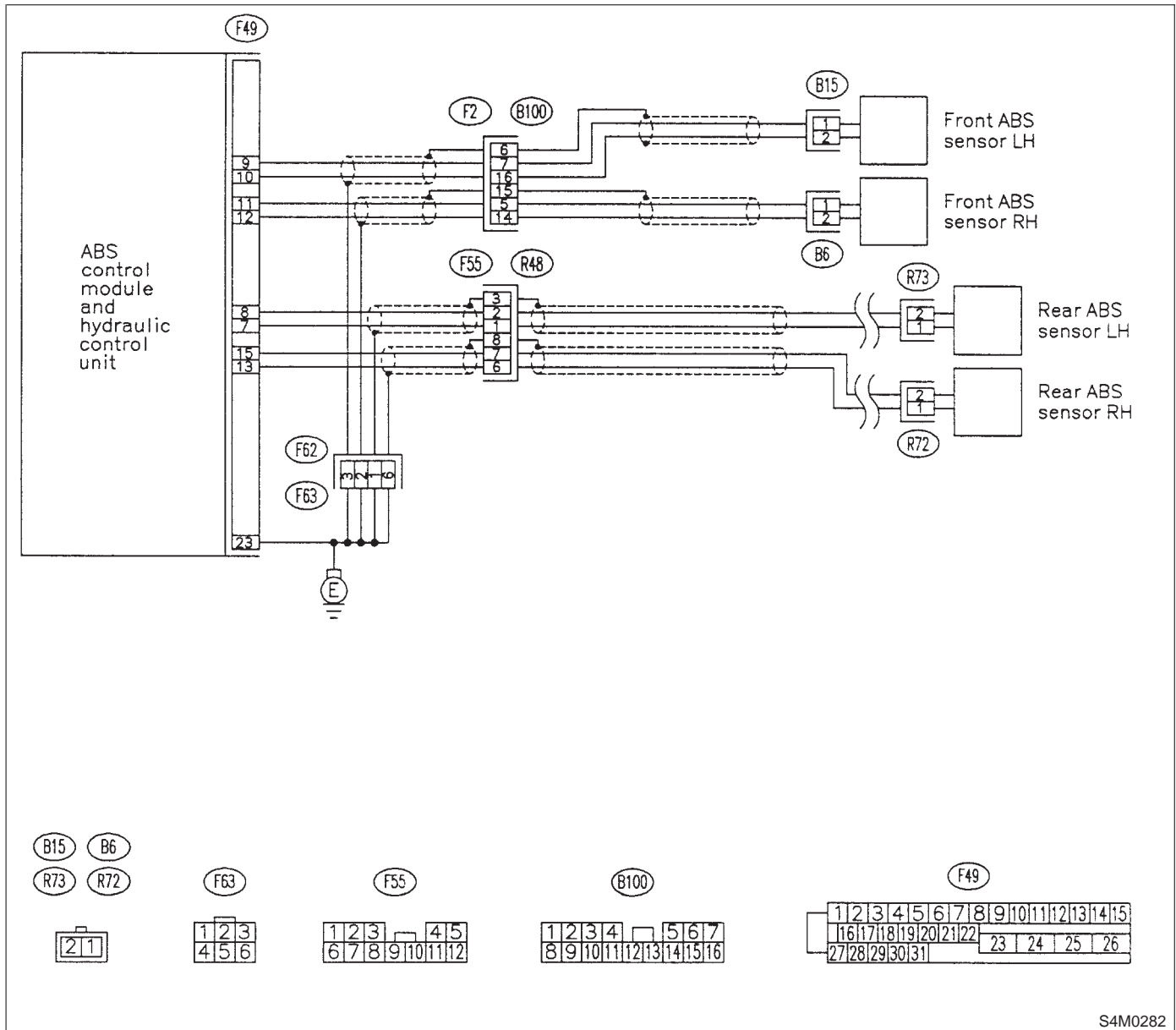

S4M0282

**811 : CHECK INSTALLATION OF ABS SENSOR.**

**Tightening torque:**

**32±10 N·m (3.3±1.0 kg·m, 24±7 ft·lb)**

**CHECK** : Are the ABS sensor installation bolts tightened securely?

**YES** : Go to step 812.

**NO** : Tighten ABS sensor installation bolts securely.

**812 : CHECK TROUBLE CODE.**

**CHECK** : Is the trouble code 26 and/or 28?

**YES** : Go to step 813.

**NO** : Go to step 814.

**813 : CHECK INSTALLATION OF REAR TONE WHEEL.**

**Tightening torque:**

**13±3 N·m (1.3±0.3 kg·m, 9±2.2 ft·lb)**

**CHECK** : Are the rear tone wheel installation bolts tightened securely?

**YES** : Go to step 814.

**NO** : Tighten rear tone wheel installation bolts securely.

**814 : CHECK ABS SENSOR GAP.**

Measure tone wheel to pole piece gap over entire perimeter of the wheel. <Ref. to 4-4 [W13C0].>

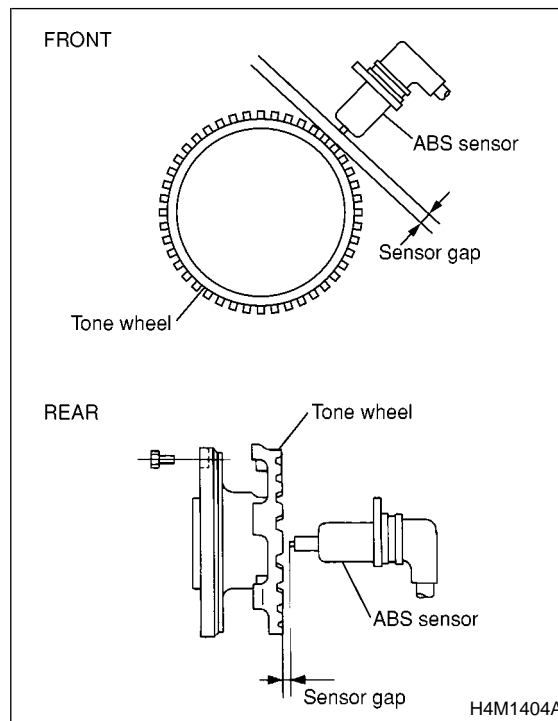

	Front wheel	Rear wheel
Specifications	0.3 — 0.8 mm (0.012 — 0.031 in)	0.7 — 1.2 mm (0.028 — 0.047 in)

**CHECK** : Is the gap within the specifications?

**YES** : Go to step 815.

**NO** : Adjust the gap.

**NOTE:**

Adjust the gap using spacer (Part No. 26755AA000). If spacers cannot correct the gap, replace worn sensor or worn tone wheel.

**815 : PREPARE OSCILLOSCOPE.**

**CHECK** : Is an oscilloscope available?

**YES** : Go to step 816.

**NO** : Go to step 817.

**816 : CHECK ABS SENSOR SIGNAL.**

- 1) Raise all four wheels of ground.
- 2) Turn ignition switch to OFF.
- 3) Connect the oscilloscope to the connector.
- 4) Turn ignition switch to ON.
- 5) Rotate wheels and measure voltage at specified frequency.

**NOTE:**

When this inspection is completed, the ABSCM&H/U sometimes stores the trouble code 29.

**Connector & terminal**

**Trouble code 22 / (B100) No. 5 (+) — No. 14 (-):**

**Trouble code 24 / (B100) No. 7 (+) — No. 16 (-):**

**Trouble code 26 / (F55) No. 6 (+) — No. 7 (-):**

**Trouble code 28 / (F55) No. 1 (+) — No. 2 (-):**

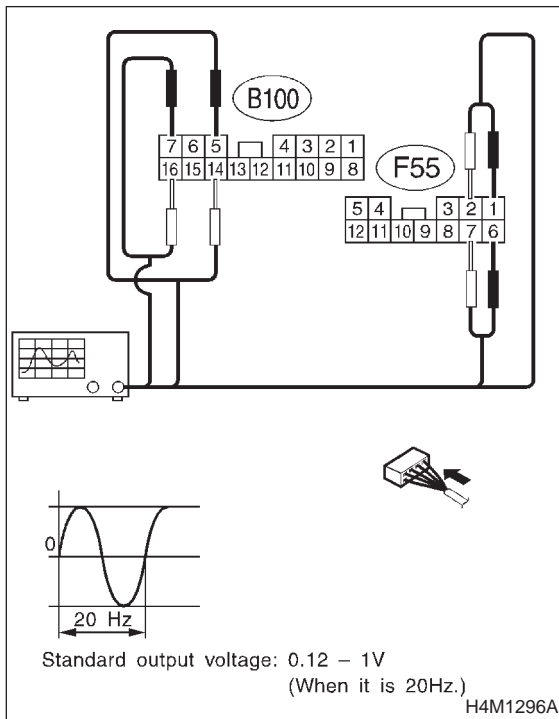

**CHECK** : *Is oscilloscope pattern smooth, as shown in figure?*

**YES** : Go to step **810**.

**NO** : Go to step **817**.

**817 : CHECK CONTAMINATION OF ABS SENSOR OR TONE WHEEL.**

Remove disc rotor or drum from hub in accordance with trouble code.

**CHECK** : *Is the ABS sensor pole piece or the tone wheel contaminated by dirt or other foreign matter?*

**YES** : Thoroughly remove dirt or other foreign matter.

**NO** : Go to step **818**.

**818 : CHECK DAMAGE OF ABS SENSOR OR TONE WHEEL.**

**CHECK** : *Are there broken or damaged in the ABS sensor pole piece or the tone wheel?*

**YES** : Replace ABS sensor or tone wheel.

**NO** : Go to step **819**.

**819 : CHECK HUB RUNOUT.**

Measure hub runout.

**CHECK** : *Is the runout less than 0.05 mm (0.0020 in)?*

**YES** : Go to step **810**.

**NO** : Repair hub.

**8I10 : CHECK RESISTANCE OF FRONT ABS SENSOR.**

- 1) Turn ignition switch to OFF.
- 2) Disconnect connector from front ABS sensor.
- 3) Measure resistance between front ABS sensor connector terminals.

**Terminals**

**RH No. 1 — No. 2:**

**LH No. 1 — No. 2:**

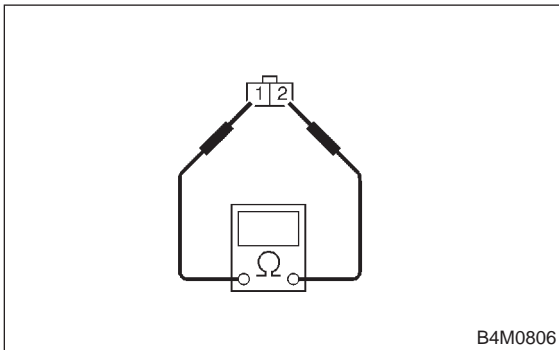

- CHECK** : *Is the resistance between 1.0 and 1.5 kΩ?*
- YES** : Go to step **8I11**.
- NO** : Replace front ABS sensor.

**8I11 : CHECK RESISTANCE OF REAR ABS SENSOR.**

- 1) Turn ignition switch to OFF.
- 2) Disconnect connector from rear ABS sensor.
- 3) Measure resistance between rear ABS sensor connector terminals.

**Terminals**

**RH No. 1 — No. 2:**

**LH No. 1 — No. 2:**

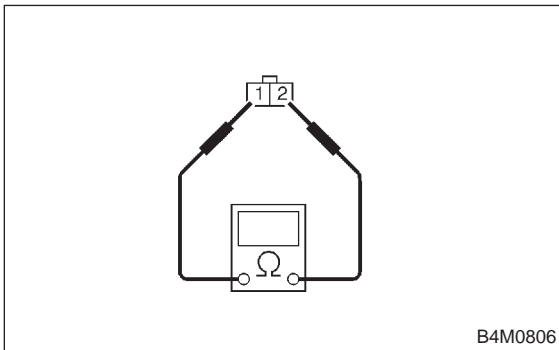

- CHECK** : *Is the resistance between 0.8 and 1.2 kΩ?*
- YES** : Go to step **8I12**.
- NO** : Replace rear ABS sensor.

**8I12 : CHECK GROUND SHORT OF ABS SENSOR.**

Measure resistance between ABS sensor and chassis ground.

**Terminals**

**Front RH No. 1 — Chassis ground:**

**Front LH No. 1 — Chassis ground:**

**Rear RH No. 1 — Chassis ground:**

**Rear LH No. 1 — Chassis ground:**

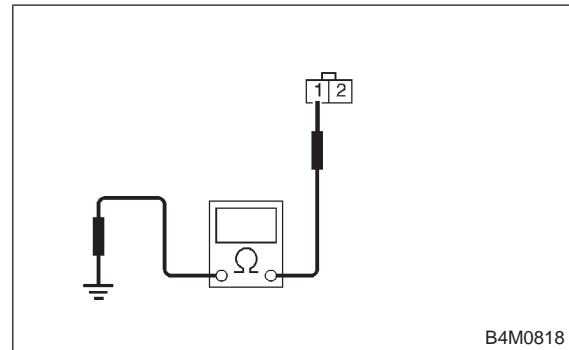

- CHECK** : *Is the resistance more than 1 MΩ?*
- YES** : Go to step **8I13**.
- NO** : Replace ABS sensor.

**8I13 : CHECK TROUBLE CODE.**

- CHECK** : *Is the trouble code 22 and/or 24?*
- YES** : Go to step **8I14**.
- NO** : Go to step **8I15**.

**8I14 : CHECK HARNESS/CONNECTOR BETWEEN ABSCM&H/U AND ABS SENSOR.**

- 1) Connect connector to ABS sensor.
- 2) Disconnect connector from ABSCM&H/U.
- 3) Measure resistance at ABSCM&H/U connector terminals.

**Connector & terminal**

**Trouble code 22 / (F49) No. 11 — No. 12:**  
**Trouble code 24 / (F49) No. 9 — No. 10:**

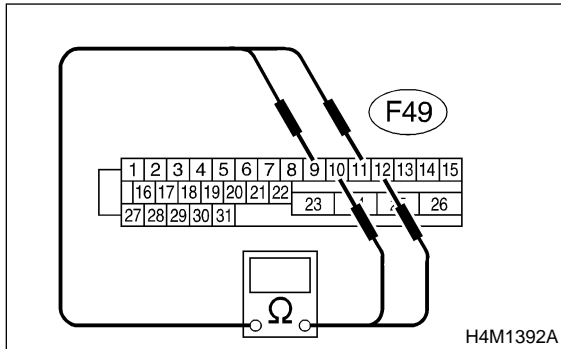

- CHECK** : Is the resistance between 1.0 and 1.5 kΩ?
- YES** : Go to step 8I16.
- NO** : Repair harness/connector between ABSCM&H/U and ABS sensor.

**8I15 : CHECK HARNESS/CONNECTOR BETWEEN ABSCM&H/U AND ABS SENSOR.**

- 1) Connect connector to ABS sensor.
- 2) Disconnect connector from ABSCM&H/U.
- 3) Measure resistance at ABSCM&H/U connector terminals.

**Connector & terminal**

**Trouble code 26 / (F49) No. 13 — No. 15:**  
**Trouble code 28 / (F49) No. 7 — No. 8:**

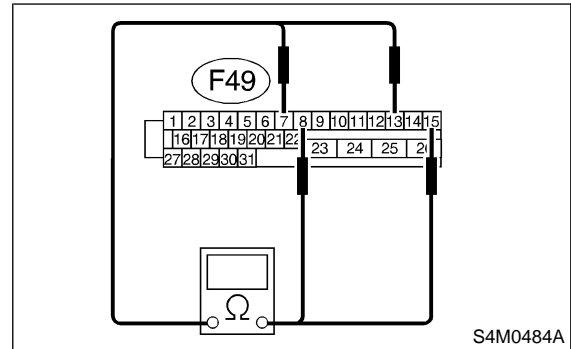

- CHECK** : Is the resistance between 0.8 and 1.2 kΩ?
- YES** : Go to step 8I16.
- NO** : Repair harness/connector between ABSCM&H/U and ABS sensor.



**8I16 : CHECK GROUND SHORT OF HARNESS.**

Measure resistance between ABSCM&H/U connector and chassis ground.

**Connector & terminal**

**Trouble code 22 / (F49) No. 11 — Chassis ground:**

**Trouble code 24 / (F49) No. 9 — Chassis ground:**

**Trouble code 26 / (F49) No. 13 — Chassis ground:**

**Trouble code 28 / (F49) No. 7 — Chassis ground:**

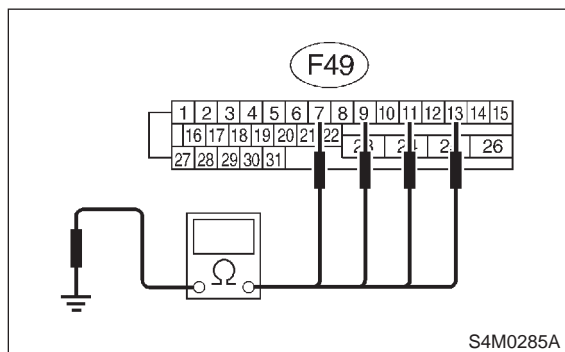

- CHECK** : *Is the resistance more than 1 MΩ?*
- YES** : Go to step **8I17**.
- NO** : Repair harness/connector between ABSCM&H/U and ABS sensor.

**8I17 : CHECK GROUND CIRCUIT OF ABSCM&H/U.**

Measure resistance between ABSCM&H/U and chassis ground.

**Connector & terminal**

**(F49) No. 23 — Chassis ground:**

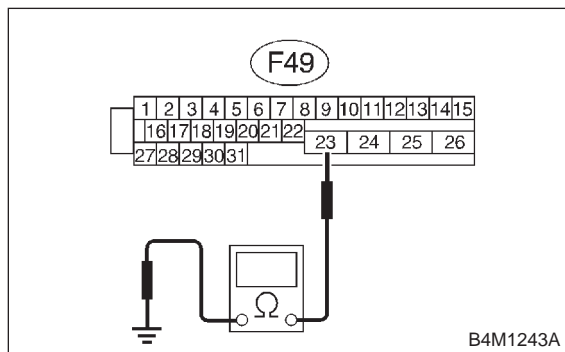

- CHECK** : *Is the resistance less than 0.5 Ω?*
- YES** : Go to step **8I18**.
- NO** : Repair ABSCM&H/U ground harness.

**8I18 : CHECK POOR CONTACT IN CONNECTORS.**

**CHECK** : *Is there poor contact in connectors between ABSCM&H/U and ABS sensor? <Ref. to FOREWORD [W3C1].>*

**YES** : Repair connector.

**NO** : Go to step **8I19**.

**8I19 : CHECK SOURCES OF SIGNAL NOISE.**

**CHECK** : *Is the car telephone or the wireless transmitter properly installed?*

**YES** : Go to step **8I20**.

**NO** : Properly install the car telephone or the wireless transmitter.

**8I20 : CHECK SOURCES OF SIGNAL NOISE.**

**CHECK** : *Are noise sources (such as an antenna) installed near the sensor harness?*

**YES** : Install the noise sources apart from the sensor harness.

**NO** : Go to step **8I21**.

**8I21 : CHECK SHIELD CIRCUIT.**

- 1) Connect all connectors.
- 2) Measure resistance between shield connector and chassis ground.

**Connector & terminal**

**Trouble code 22 / (B100) No. 15 — Chassis ground:**

**Trouble code 24 / (B100) No. 6 — Chassis ground:**

**Trouble code 26 / (F55) No. 8 — Chassis ground:**

**Trouble code 28 / (F55) No. 3 — Chassis ground:**

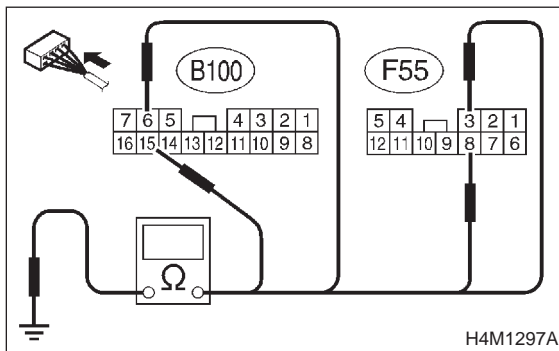

- CHECK** : **Is the resistance less than 0.5 Ω?**
- YES** : Go to step **8I22**.
- NO** : Repair shield harness.

**8I22 : CHECK ABSCM&H/U.**

- 1) Connect all connectors.
- 2) Erase the memory.
- 3) Perform inspection mode.
- 4) Read out the trouble code.

- CHECK** : **Is the same trouble code as in the current diagnosis still being output?**
- YES** : Replace ABSCM&H/U. <Ref. to 4-4 [W14A0].>
- NO** : Go to step **8I23**.

**8I23 : CHECK ANY OTHER TROUBLE CODES APPEARANCE.**

- CHECK** : **Are other trouble codes being output?**
- YES** : Proceed with the diagnosis corresponding to the trouble code.
- NO** : A temporary noise interference.

**MEMO:**

**J: TROUBLE CODE 29**  
**— ABNORMAL ABS SENSOR SIGNAL (ANY ONE OF FOUR) —**

**DIAGNOSIS:**

- Faulty ABS sensor signal (noise, irregular signal, etc.)
- Faulty tone wheel
- Wheels turning freely for a long time

**TROUBLE SYMPTOM:**

- ABS does not operate.

**WIRING DIAGRAM:**

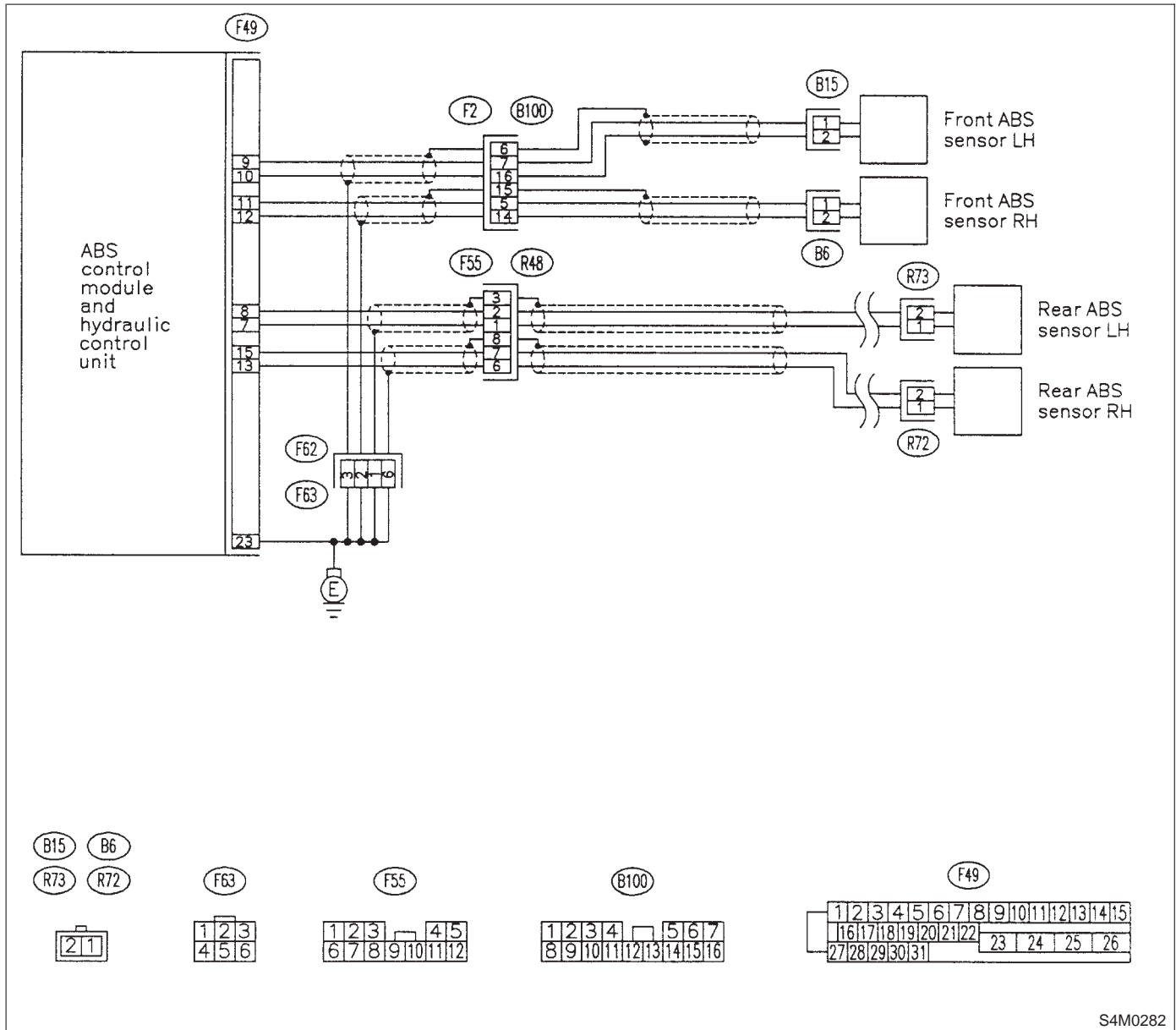

S4M0282

**8J1 : CHECK IF THE WHEELS HAVE TURNED FREELY FOR A LONG TIME.**

- CHECK** : *Check if the wheels have been turned freely for more than one minute, such as when the vehicle is jacked-up, under full-lock cornering or when tire is not in contact with road surface.*
- YES** : The ABS is normal. Erase the trouble code.

**NOTE:**

When the wheels turn freely for a long time, such as when the vehicle is towed or jacked-up, or when steering wheel is continuously turned all the way, this trouble code may sometimes occur.

- NO** : Go to step **8J2**.

**8J2 : CHECK TIRE SPECIFICATIONS.**

- CHECK** : *Are the tire specifications correct?*
- YES** : Go to step **8J3**.
- NO** : Replace tire.

**8J3 : CHECK WEAR OF TIRE.**

- CHECK** : *Is the tire worn excessively?*
- YES** : Replace tire.
- NO** : Go to step **8J4**.

**8J4 : CHECK TIRE PRESSURE.**

- CHECK** : *Is the tire pressure correct?*
- YES** : Go to step **8J5**.
- NO** : Adjust tire pressure.

**8J5 : CHECK INSTALLATION OF ABS SENSOR.**

**Tightening torque:**

**32±10 N·m (3.3±1.0 kg·m, 24±7 ft·lb)**

- CHECK** : *Are the ABS sensor installation bolts tightened securely?*
- YES** : Go to step **8J6**.
- NO** : Tighten ABS sensor installation bolts securely.

**8J6 : CHECK INSTALLATION OF REAR TONE WHEEL.**

**Tightening torque:**

**13±3 N·m (1.3±0.3 kg·m, 9±2.2 ft·lb)**

- CHECK** : *Are the rear tone wheel installation bolts tightened securely?*
- YES** : Go to step **8J7**.
- NO** : Tighten rear tone wheel installation bolts securely.

**8J7 : CHECK ABS SENSOR GAP.**

Measure tone wheel to pole piece gap over entire perimeter of the wheel. <Ref. to 4-4 [W13C0].>

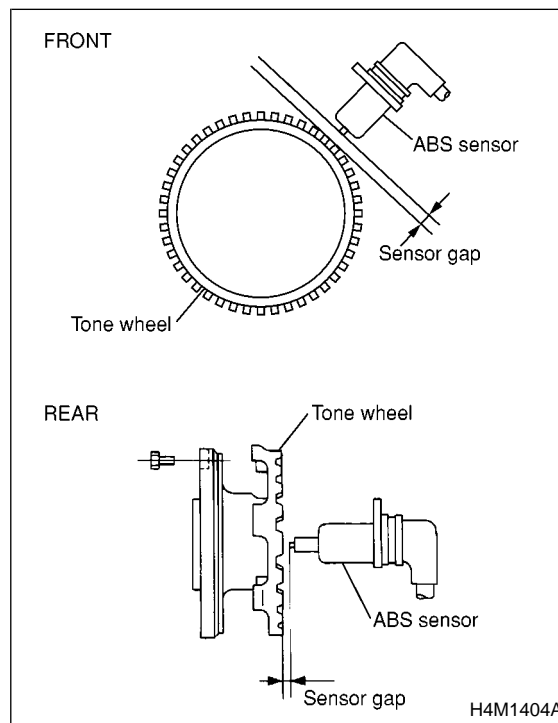

	Front wheel	Rear wheel
Specifications	0.3 — 0.8 mm (0.012 — 0.031 in)	0.7 — 1.2 mm (0.028 — 0.047 in)

- CHECK** : *Is the gap within the specifications?*
- YES** : Go to step **8J8**.
- NO** : Adjust the gap.

**NOTE:**

Adjust the gap using spacer (Part No. 26755AA000). If spacers cannot correct the gap, replace worn sensor or worn tone wheel.

**8J8 : PREPARE OSCILLOSCOPE.**

- CHECK** : *Is an oscilloscope available?*
- YES** : Go to step **8J9**.
- NO** : Go to step **8J10**.

**8J9 : CHECK ABS SENSOR SIGNAL.**

- 1) Raise all four wheels of ground.
- 2) Turn ignition switch to OFF.
- 3) Connect the oscilloscope to the connector.
- 4) Turn ignition switch to ON.
- 5) Rotate wheels and measure voltage at specified frequency.

**NOTE:**  
When this inspection is completed, the ABSCM&H/U sometimes stores the trouble code 29.

**Connector & terminal**  
**(B100) No. 5 (+) — No. 14 (-) (Front RH):**  
**(B100) No. 7 (+) — No. 16 (-) (Front LH):**  
**(F55) No. 6 (+) — No. 7 (-) (Rear RH):**  
**(F55) No. 1 (+) — No. 2 (-) (Rear LH):**

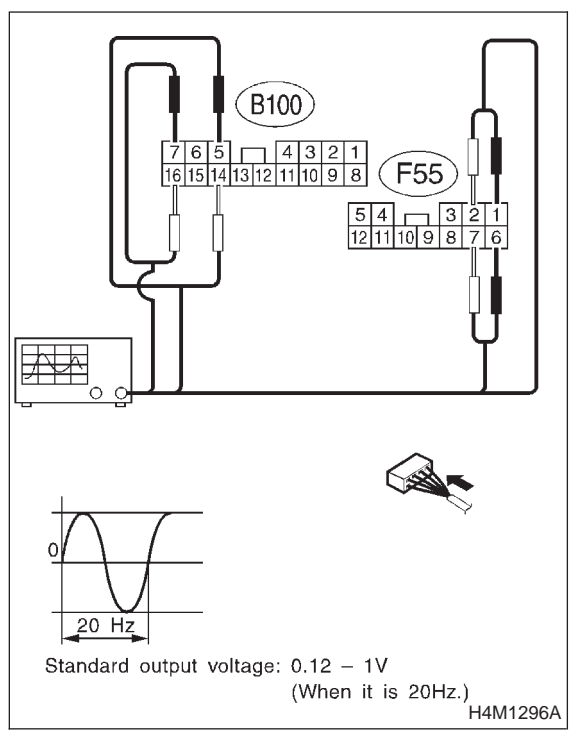

- CHECK** : *Is oscilloscope pattern smooth, as shown in figure?*
- YES** : Go to step **8J13**.
- NO** : Go to step **8J10**.

**8J10 : CHECK CONTAMINATION OF ABS SENSOR OR TONE WHEEL.**

- Remove disc rotor from hub.
- CHECK** : *Is the ABS sensor pole piece or the tone wheel contaminated by dirt or other foreign matter?*
  - YES** : Thoroughly remove dirt or other foreign matter.
  - NO** : Go to step **8J11**.

**8J11 : CHECK DAMAGE OF ABS SENSOR OR TONE WHEEL.**

- CHECK** : *Are there broken or damaged teeth in the ABS sensor pole piece or the tone wheel?*
- YES** : Replace ABS sensor or tone wheel.
- NO** : Go to step **8J12**.

**8J12 : CHECK HUB RUNOUT.**

- Measure hub runout.
- CHECK** : *Is the runout less than 0.05 mm (0.0020 in)?*
  - YES** : Go to step **8J13**.
  - NO** : Repair hub.

**8J13 : CHECK ABSCM&H/U.**

- 1) Turn ignition switch to OFF.
  - 2) Connect all connectors.
  - 3) Erase the memory.
  - 4) Perform inspection mode.
  - 5) Read out the trouble code.
- CHECK** : *Is the same trouble code as in the current diagnosis still being output?*
  - YES** : Replace ABSCM&H/U. <Ref. to 4-4 [W14A0].>
  - NO** : Go to step **8J14**.

**8J14 : CHECK ANY OTHER TROUBLE CODES APPEARANCE.**

- CHECK** : *Are other trouble codes being output?*
- YES** : Proceed with the diagnosis corresponding to the trouble code.
- NO** : A temporary poor contact.

**MEMO:**

**K: TROUBLE CODE 31 (FRONT RH)**

**L: TROUBLE CODE 33 (FRONT LH)**

**M: TROUBLE CODE 35 (REAR RH)**

**N: TROUBLE CODE 37 (REAR LH)**

**— ABNORMAL INLET SOLENOID VALVE CIRCUIT(S) IN ABSCM&H/U —**

**DIAGNOSIS:**

- Faulty harness/connector
- Faulty inlet solenoid valve in ABSCM&H/U

**TROUBLE SYMPTOM:**

- ABS does not operate.

**WIRING DIAGRAM:**

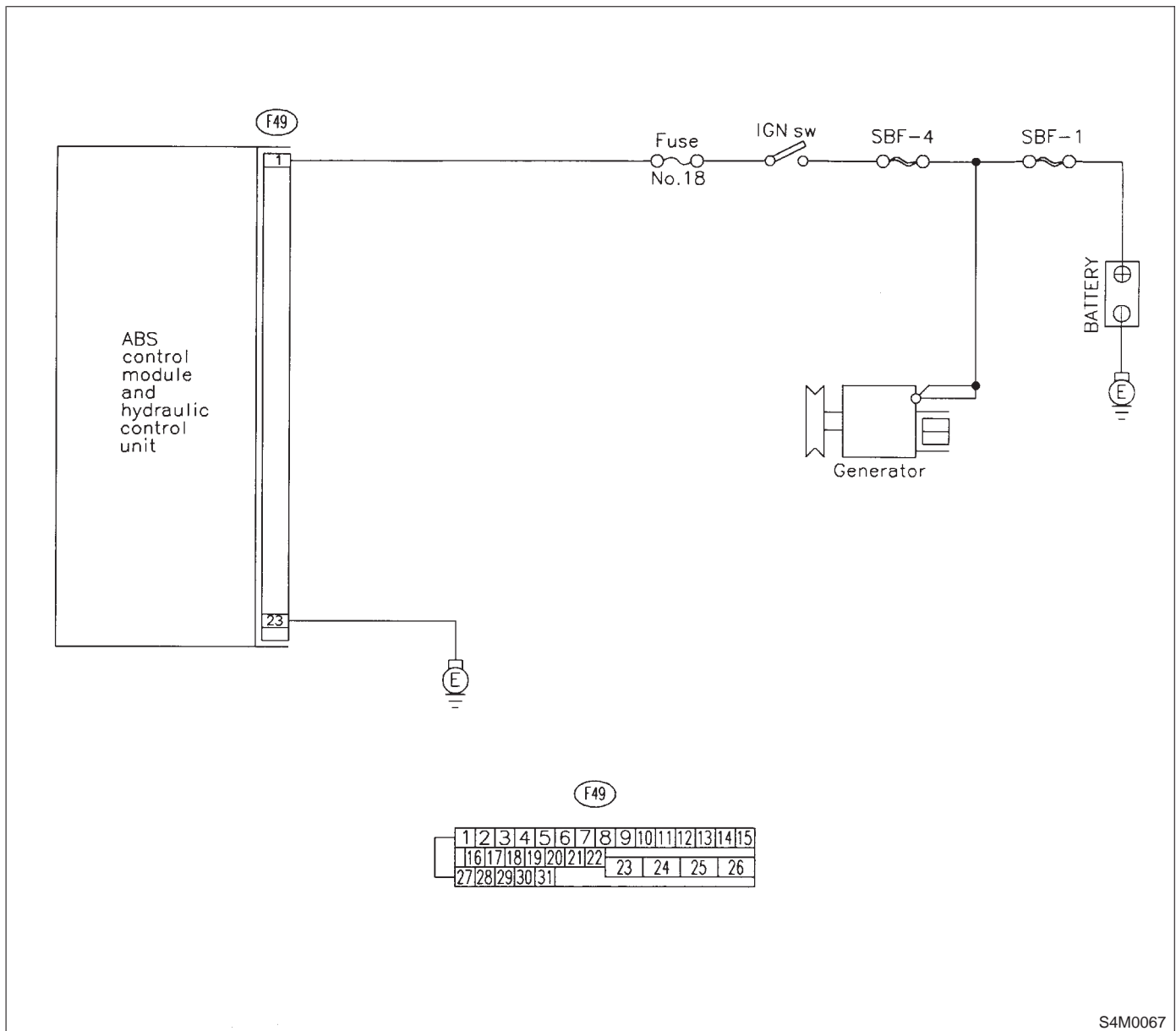

S4M0067



**8N1 : CHECK INPUT VOLTAGE OF ABSCM&H/U.**

- 1) Turn ignition switch to OFF.
- 2) Disconnect connector from ABSCM&H/U.
- 3) Run the engine at idle.
- 4) Measure voltage between ABSCM&H/U connector and chassis ground.

**Connector & terminal**  
**(F49) No. 1 (+) — Chassis ground (-):**

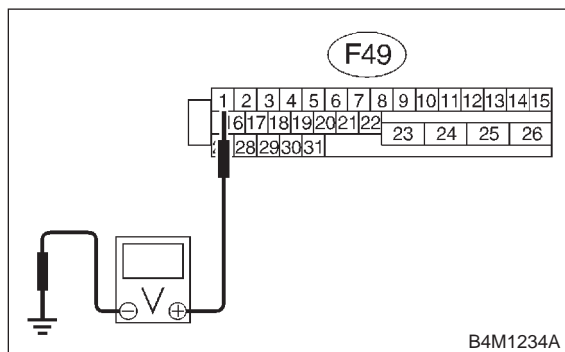

- CHECK** : *Is the voltage between 10 and 15 V?*
- YES** : Go to step **8N2**.
- NO** : Repair harness connector between battery, ignition switch and ABSCM&H/U.

**8N2 : CHECK GROUND CIRCUIT OF ABSCM&H/U.**

- 1) Turn ignition switch to OFF.
- 2) Measure resistance between ABSCM&H/U connector and chassis ground.

**Connector & terminal**  
**(F49) No. 23 — Chassis ground:**

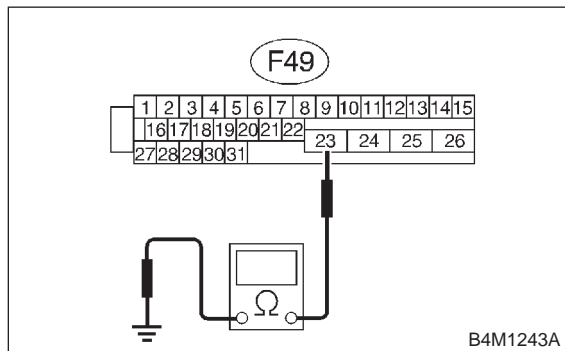

- CHECK** : *Is the resistance less than 0.5 Ω?*
- YES** : Go to step **8N3**.
- NO** : Repair ABSCM&H/U ground harness.

**8N3 : CHECK POOR CONTACT IN CONNECTORS.**

- CHECK** : *Is there poor contact in connectors between generator, battery and ABSCM&H/U? <Ref. to FOREWORD [W3C1]. >*
- YES** : Repair connector.
- NO** : Go to step **8N4**.

**8N4 : CHECK ABSCM&H/U.**

- 1) Connect all connectors.
  - 2) Erase the memory.
  - 3) Perform inspection mode.
  - 4) Read out the trouble code.
- CHECK** : *Is the same trouble code as in the current diagnosis still being output?*
- YES** : Replace ABSCM&H/U. <Ref. to 4-4 [W14A0].>
- NO** : Go to step **8N5**.

**8N5 : CHECK ANY OTHER TROUBLE CODES APPEARANCE.**

- CHECK** : *Are other trouble codes being output?*
- YES** : Proceed with the diagnosis corresponding to the trouble code.
- NO** : A temporary poor contact.

O: TROUBLE CODE 32 (FRONT RH)

P: TROUBLE CODE 34 (FRONT LH)

Q: TROUBLE CODE 36 (REAR RH)

R: TROUBLE CODE 38 (REAR LH)

— ABNORMAL OUTLET SOLENOID VALVE CIRCUIT(S) IN ABSCM&H/U —

**DIAGNOSIS:**

- Faulty harness/connector
- Faulty outlet solenoid valve in ABSCM&H/U

**TROUBLE SYMPTOM:**

- ABS does not operate.

**WIRING DIAGRAM:**

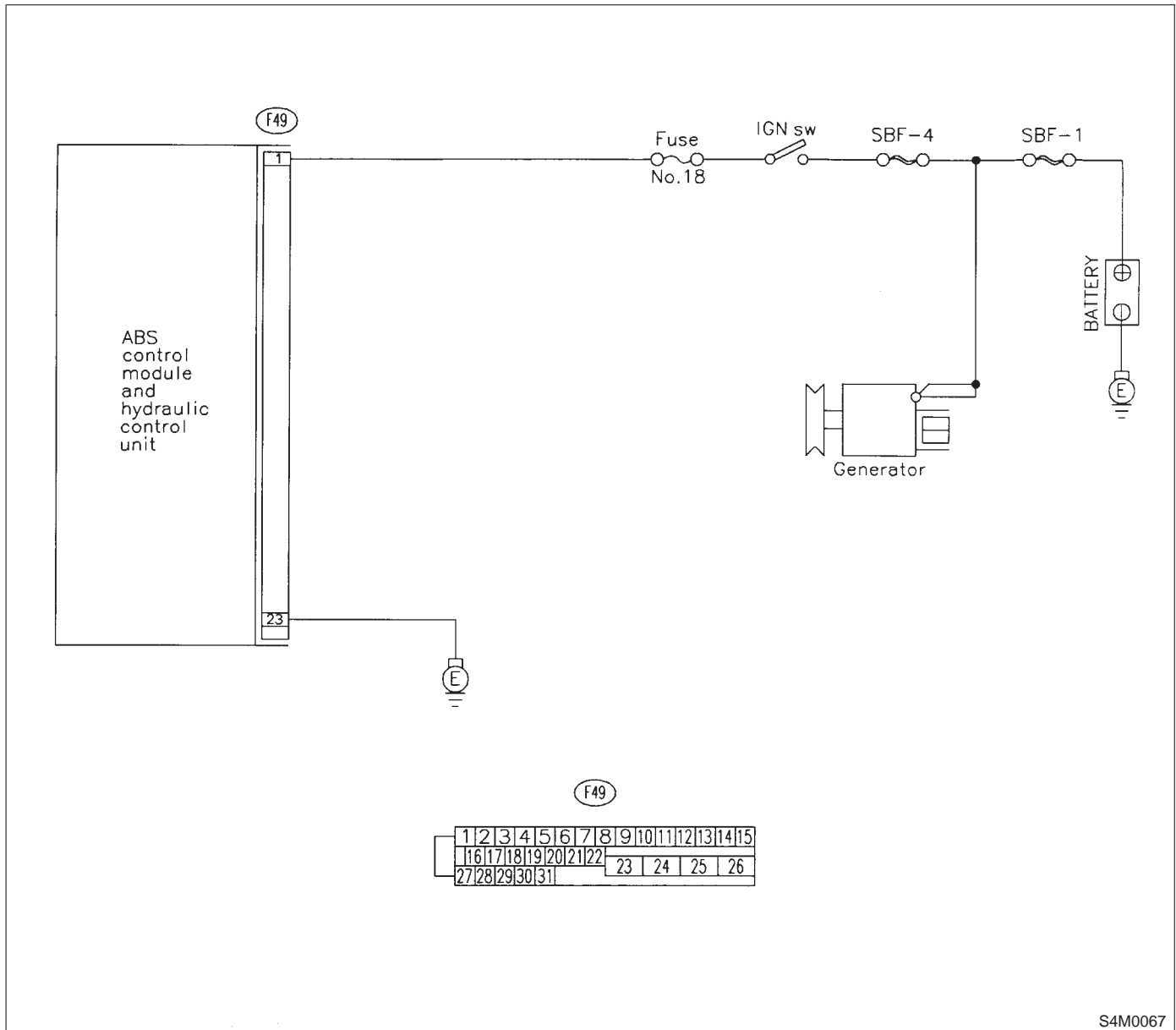

S4M0067

**8R1 : CHECK INPUT VOLTAGE OF ABSCM&H/U.**

- 1) Turn ignition switch to OFF.
- 2) Disconnect connector from ABSCM&H/U.
- 3) Run the engine at idle.
- 4) Measure voltage between ABSCM&H/U connector and chassis ground.

**Connector & terminal**  
**(F49) No. 1 (+) — Chassis ground (-):**

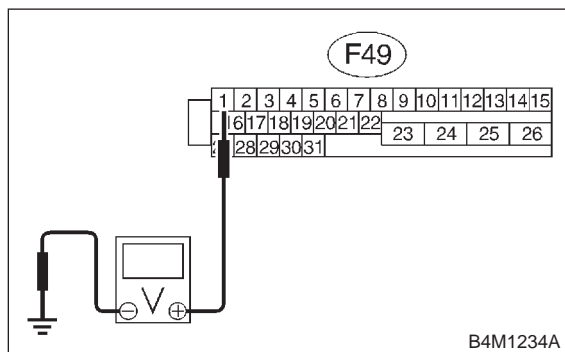

- CHECK** : *Is the voltage between 10 and 15 V?*
- YES** : Go to step **8R2**.
- NO** : Repair harness connector between battery, ignition switch and ABSCM&H/U.

**8R2 : CHECK GROUND CIRCUIT OF ABSCM&H/U.**

- 1) Turn ignition switch to OFF.
- 2) Measure resistance between ABSCM&H/U connector and chassis ground.

**Connector & terminal**  
**(F49) No. 23 — Chassis ground:**

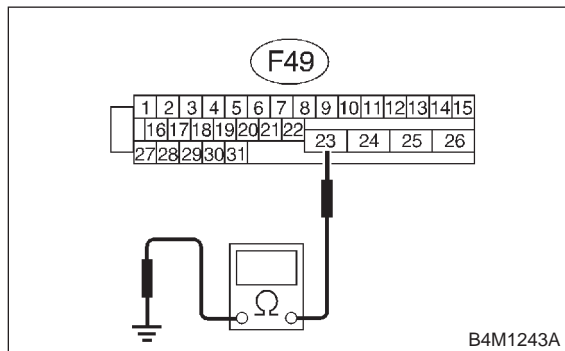

- CHECK** : *Is the resistance less than 0.5 Ω?*
- YES** : Go to step **8R3**.
- NO** : Repair ABSCM&H/U ground harness.

**8R3 : CHECK POOR CONTACT IN CONNECTORS.**

- CHECK** : *Is there poor contact in connectors between generator, battery and ABSCM&H/U? <Ref. to FOREWORD [W3C1]. >*
- YES** : Repair connector.
- NO** : Go to step **8R4**.

**8R4 : CHECK ABSCM&H/U.**

- 1) Connect all connectors.
  - 2) Erase the memory.
  - 3) Perform inspection mode.
  - 4) Read out the trouble code.
- CHECK** : *Is the same trouble code as in the current diagnosis still being output?*
- YES** : Replace ABSCM&H/U. <Ref. to 4-4 [W14A0].>
- NO** : Go to step **8R5**.

**8R5 : CHECK ANY OTHER TROUBLE CODES APPEARANCE.**

- CHECK** : *Are other trouble codes being output?*
- YES** : Proceed with the diagnosis corresponding to the trouble code.
- NO** : A temporary poor contact.

**S: TROUBLE CODE 41**  
**— ABNORMAL ABS CONTROL MODULE —**

**DIAGNOSIS:**

- Faulty ABSCM&H/U.

**TROUBLE SYMPTOM:**

- ABS does not operate.

**WIRING DIAGRAM:**

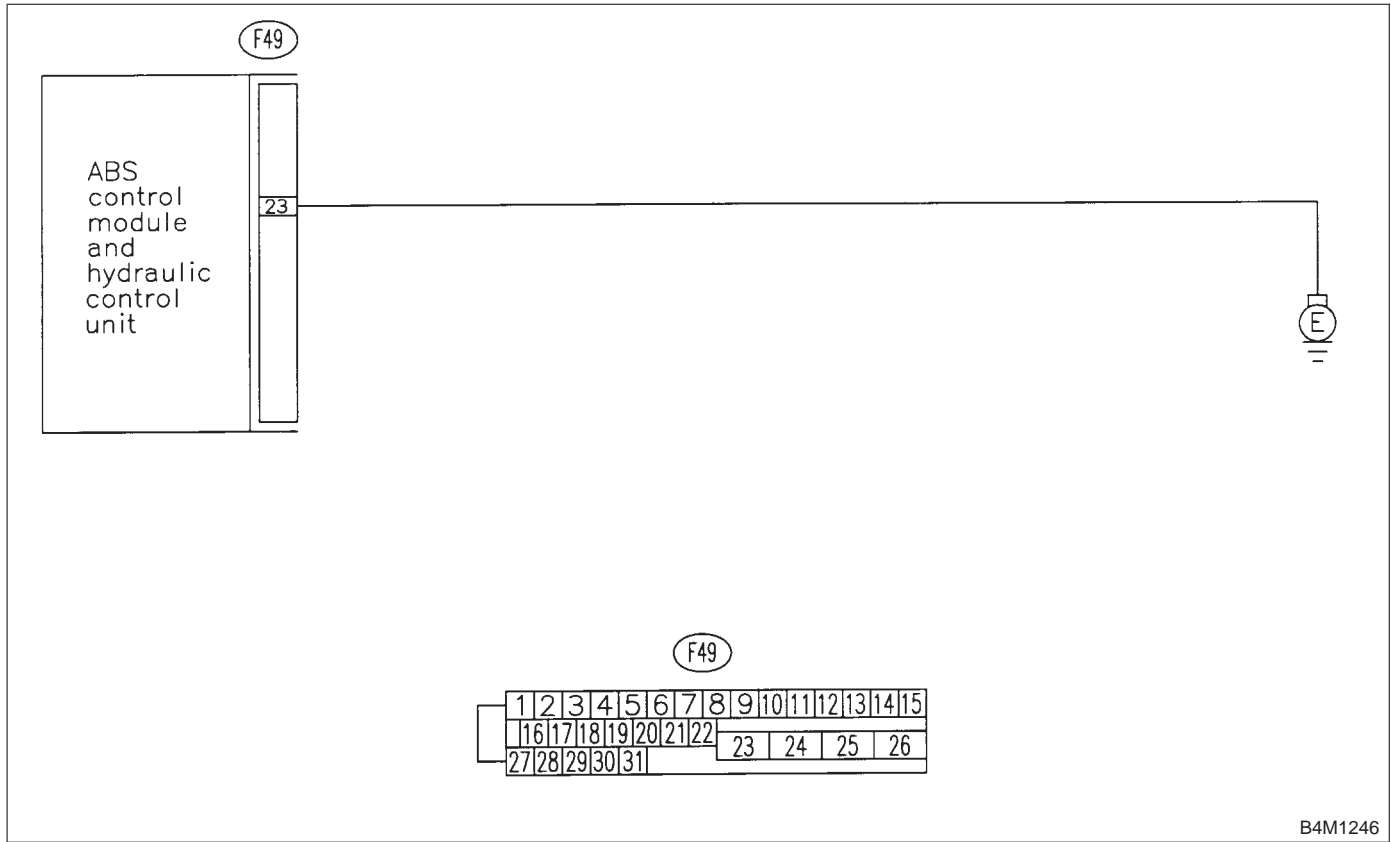

B4M1246

**8S1 : CHECK GROUND CIRCUIT OF ABSCM&H/U.**

- 1) Turn ignition switch to OFF.
- 2) Disconnect connector from ABSCM&H/U.
- 3) Measure resistance between ABSCM&H/U and chassis ground.

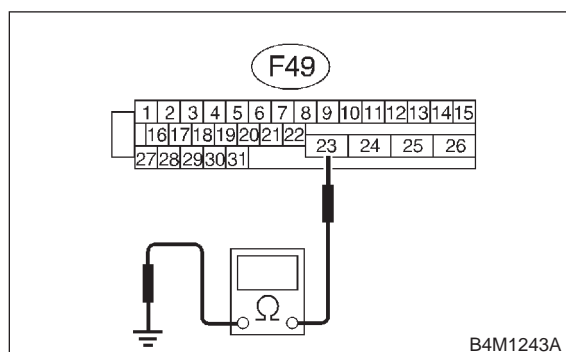
**Connector & terminal****(F49) No. 23 — Chassis ground:**

- CHECK** : *Is the resistance less than 0.5 Ω?*
- YES** : Go to step **8S2**.
- NO** : Repair ABSCM&H/U ground harness.

**8S2 : CHECK POOR CONTACT IN CONNECTORS.**

- CHECK** : *Is there poor contact in connectors between battery, ignition switch and ABSCM&H/U? <Ref. to FOREWORD [W3C1]. >*
- YES** : Repair connector.
- NO** : Go to step **8S3**.

**8S3 : CHECK SOURCES OF SIGNAL NOISE.**

- CHECK** : *Is the car telephone or the wireless transmitter properly installed?*
- YES** : Go to step **8S4**.
- NO** : Properly install the car telephone or the wireless transmitter.

**8S4 : CHECK SOURCES OF SIGNAL NOISE.**

- CHECK** : *Are noise sources (such as an antenna) installed near the sensor harness?*
- YES** : Install the noise sources apart from the sensor harness.
- NO** : Go to step **8S5**.

**8S5 : CHECK ABSCM&H/U.**

- 1) Connect all connectors.
  - 2) Erase the memory.
  - 3) Perform inspection mode.
  - 4) Read out the trouble code.
- CHECK** : *Is the same trouble code as in the current diagnosis still being output?*
- YES** : Replace ABSCM&H/U. <Ref. to 4-4 [W14A0].>
- NO** : Go to step **8S6**.

**8S6 : CHECK ANY OTHER TROUBLE CODES APPEARANCE.**

- CHECK** : *Are other trouble codes being output?*
- YES** : Proceed with the diagnosis corresponding to the trouble code.
- NO** : A temporary poor contact.

T: TROUBLE CODE 42  
— SOURCE VOLTAGE IS ABNORMAL. —

DIAGNOSIS:

- Power source voltage of the ABSCM&H/U is low or high.

TROUBLE SYMPTOM:

- ABS does not operate.

WIRING DIAGRAM:

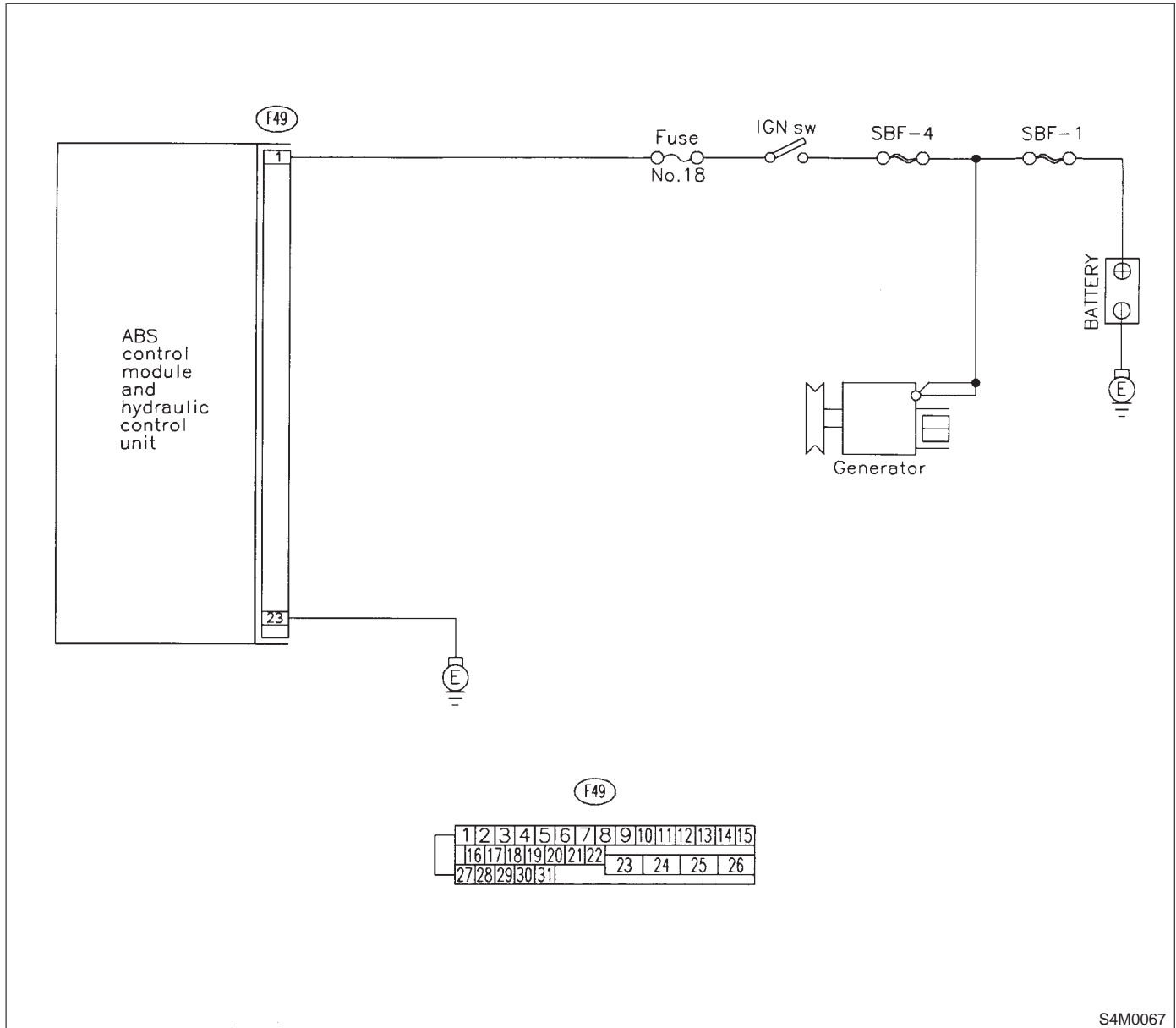

S4M0067

**8T1 : CHECK GENERATOR.**

- 1) Start engine.
- 2) Idling after warm-up.
- 3) Measure voltage between generator B terminal and chassis ground.

**Terminals**

**Generator B terminal — Chassis ground:**

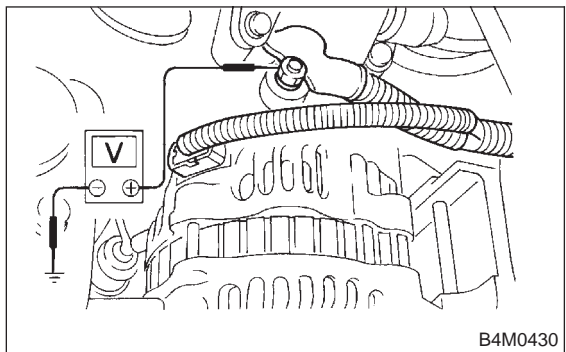

- CHECK** : *Is the voltage between 10 and 15 V?*
- YES** : Go to step 8T2.
- NO** : Repair generator. <Ref. to 6-1 [W2A0].>

**8T2 : CHECK BATTERY TERMINAL.**

Turn ignition switch to OFF.

- CHECK** : *Are the positive and negative battery terminals tightly clamped?*
- YES** : Go to step 8T3.
- NO** : Tighten the clamp of terminal.

**8T3 : CHECK INPUT VOLTAGE OF ABSCM&H/U.**

- 1) Disconnect connector from ABSCM&H/U.
- 2) Run the engine at idle.
- 3) Measure voltage between ABSCM&H/U connector and chassis ground.

**Connector & terminal**

**(F49) No. 1 (+) — Chassis ground (-):**

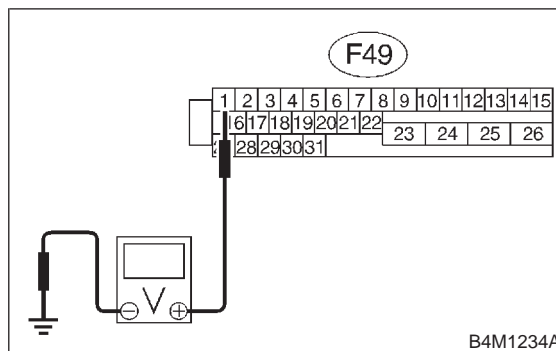

- CHECK** : *Is the voltage between 10 and 15 V?*
- YES** : Go to step 8T4.
- NO** : Repair harness connector between battery, ignition switch and ABSCM&H/U.

**8T4 : CHECK GROUND CIRCUIT OF ABSCM&H/U.**

- 1) Turn ignition switch to OFF.
- 2) Measure resistance between ABSCM&H/U connector and chassis ground.

**Connector & terminal**

**(F49) No. 23 — Chassis ground:**

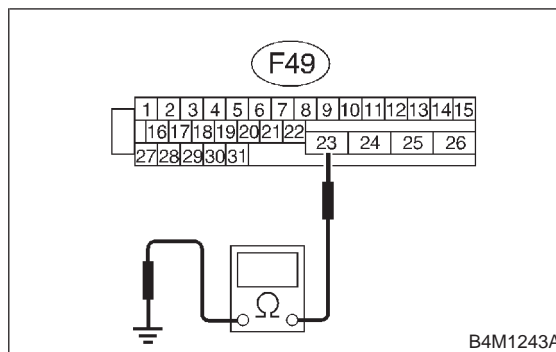

- CHECK** : *Is the resistance less than 0.5 Ω?*
- YES** : Go to step 8T5.
- NO** : Repair ABSCM&H/U ground harness.

**8T5 : CHECK POOR CONTACT IN CONNECTORS.**

**CHECK** : *Is there poor contact in connectors between generator, battery and ABSCM&H/U? <Ref. to FOREWORD [W3C1]. >*

**YES** : Repair connector.

**NO** : Go to step 8T6.

**8T6 : CHECK ABSCM&H/U.**

- 1) Connect all connectors.
- 2) Erase the memory.
- 3) Perform inspection mode.
- 4) Read out the trouble code.

**CHECK** : *Is the same trouble code as in the current diagnosis still being output?*

**YES** : Replace ABSCM&H/U. <Ref. to 4-4 [W14A0].>

**NO** : Go to step 8T7.

**8T7 : CHECK ANY OTHER TROUBLE CODES APPEARANCE.**

**CHECK** : *Are other trouble codes being output?*

**YES** : Proceed with the diagnosis corresponding to the trouble code.

**NO** : A temporary poor contact.



**MEMO:**

**U: TROUBLE CODE 44**  
**— A COMBINATION OF AT CONTROL ABNORMAL —**

**DIAGNOSIS:**

- Combination of AT control faults

**TROUBLE SYMPTOM:**

- ABS does not operate.

**WIRING DIAGRAM:**

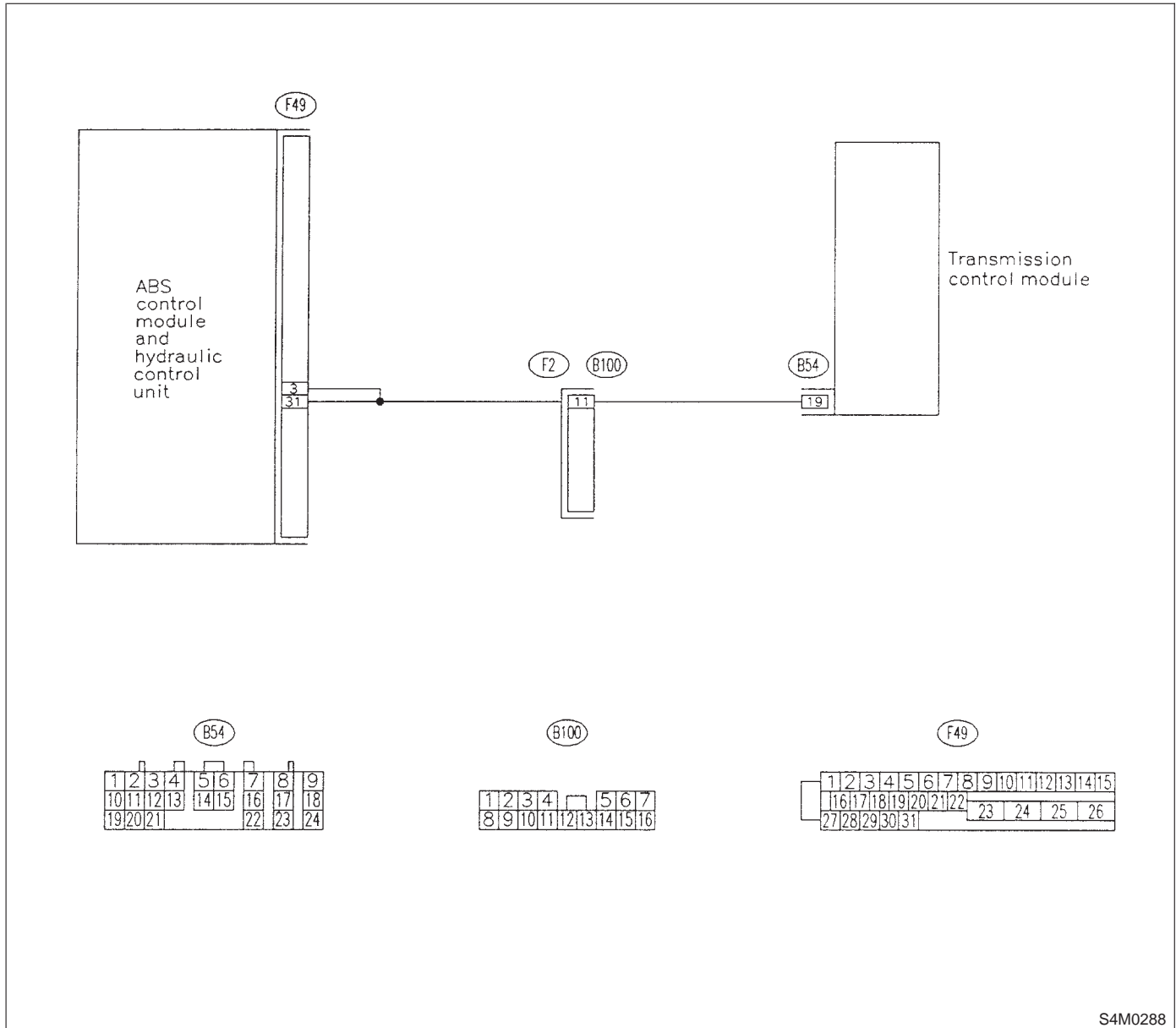

S4M0288

**8U1 : CHECK SPECIFICATIONS OF THE ABSCM&H/U.**

Check specifications of the mark to the ABSCM&H/U.

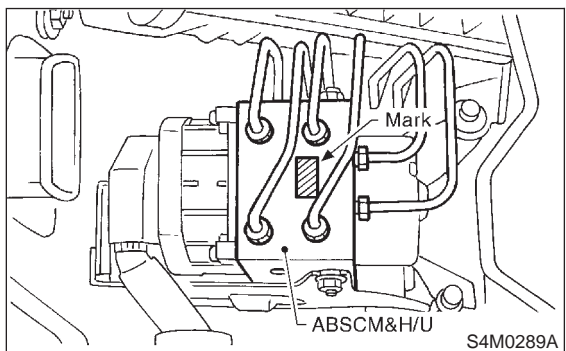

Mark	Model
C7	AWD AT
C8	AWD MT

**CHECK** : Is an ABSCM&H/U for AT model installed on a MT model?

**YES** : Replace ABSCM&H/U. <Ref. to 4-4 [W14A0].>

**NO** : Go to step 8U2.

**8U2 : CHECK GROUND SHORT OF HARNESS.**

- 1) Turn ignition switch to OFF.
- 2) Disconnect the two connectors from TCM.
- 3) Disconnect connector from ABSCM&H/U.
- 4) Measure resistance between ABSCM&H/U connector and chassis ground.

**Connector & terminal (F49) No. 3 — Chassis ground:**

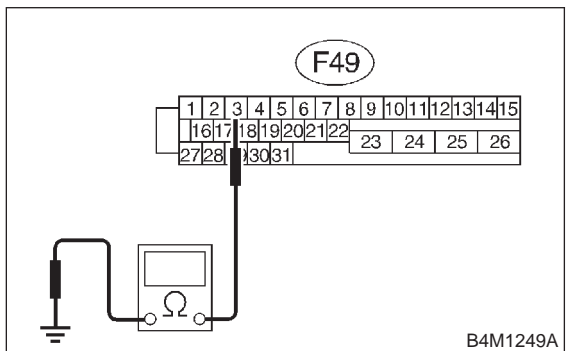

**CHECK** : Is the resistance more than 1 MΩ?

**YES** : Go to step 8U3.

**NO** : Repair harness between TCM and ABSCM&H/U.

**8U3 : CHECK BATTERY SHORT OF HARNESS.**

Measure voltage between ABSCM&H/U connector and chassis ground.

**Connector & terminal (F49) No. 3 (+) — Chassis ground (-):**

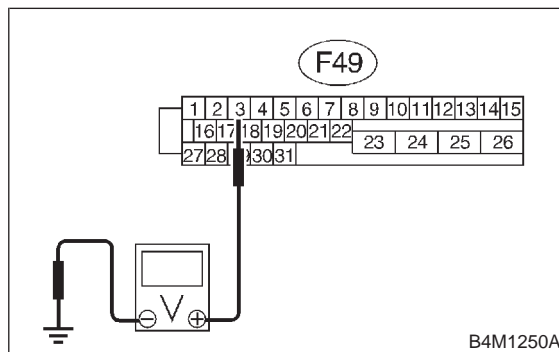

**CHECK** : Is the voltage less than 1 V?

**YES** : Go to step 8U4.

**NO** : Repair harness between TCM and ABSCM&H/U.

**8U4 : CHECK BATTERY SHORT OF HARNESS.**

- 1) Turn ignition switch to ON.
- 2) Measure voltage between ABSCM&H/U connector and chassis ground.

**Connector & terminal (F49) No. 3 (+) — Chassis ground (-):**

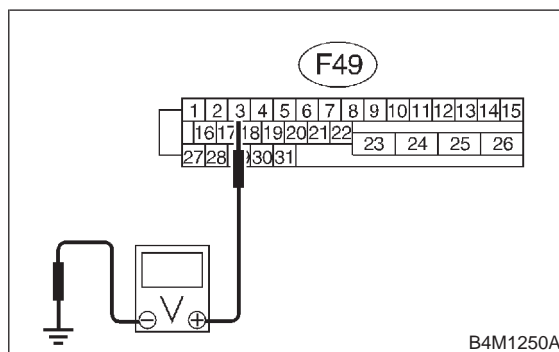

**CHECK** : Is the voltage less than 1 V?

**YES** : Go to step 8U5.

**NO** : Repair harness between TCM and ABSCM&H/U.

**8U5 : CHECK TCM.**

- 1) Turn ignition switch to OFF.
- 2) Connect all connectors to TCM.
- 3) Turn ignition switch to ON.
- 4) Measure voltage between TCM connector terminal and chassis ground.

**Connector & terminal**  
**(B54) No. 19 (+) — Chassis ground (-):**

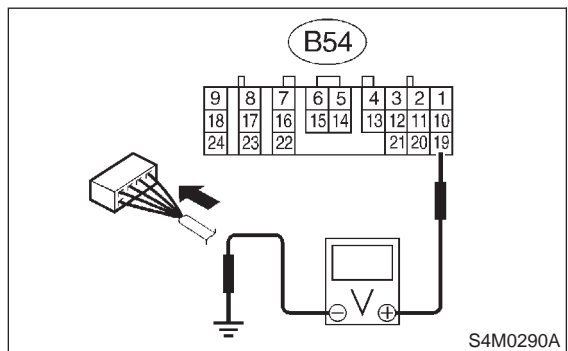

- CHECK** : Is the voltage between 6 and 15 V?
- YES** : Go to step 8U7.
- NO** : Go to step 8U6.

**8U6 : CHECK AT.**

- CHECK** : Is the AT functioning normally?
- YES** : Replace TCM. <Ref. to 3-2 [W23A0].>
- NO** : Repair AT. <Ref. to 3-2 [T100].>

**8U7 : CHECK OPEN CIRCUIT OF HARNESS.**

Measure voltage between ABSCM&H/U connector and chassis ground.

**Connector & terminal**  
**(F49) No. 3 (+) — Chassis ground (-):**  
**(F49) No. 31 (+) — Chassis ground (-):**

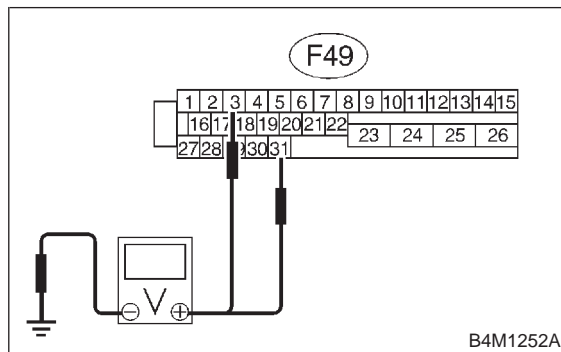

- CHECK** : Is the voltage between 5.5 and 15 V?
- YES** : Go to step 8U8.
- NO** : Repair harness/connector between TCM and ABSCM&H/U.

**8U8 : CHECK POOR CONTACT IN CONNECTORS.**

- CHECK** : Is there poor contact in connectors between TCM and ABSCM&H/U? <Ref. to FOREWORD [W3C1]. >
- YES** : Repair connector.
- NO** : Go to step 8U9.

**8U9 : CHECK ABSCM&H/U.**

- 1) Turn ignition switch to OFF.
- 2) Connect all connectors.
- 3) Erase the memory.
- 4) Perform inspection mode.
- 5) Read out the trouble code.

- CHECK** : Is the same trouble code as in the current diagnosis still being output?
- YES** : Replace ABSCM&H/U. <Ref. to 4-4 [W14A0].>
- NO** : Go to step 8U10.

**8U10 : CHECK ANY OTHER TROUBLE CODES APPEARANCE.**

- CHECK** : *Are other trouble codes being output?*
- YES** : Proceed with the diagnosis corresponding to the trouble code.
- NO** : A temporary poor contact.

**V: TROUBLE CODE 51**  
**— ABNORMAL VALVE RELAY —**

**DIAGNOSIS:**

- Faulty valve relay

**TROUBLE SYMPTOM:**

- ABS does not operate.

**WIRING DIAGRAM:**

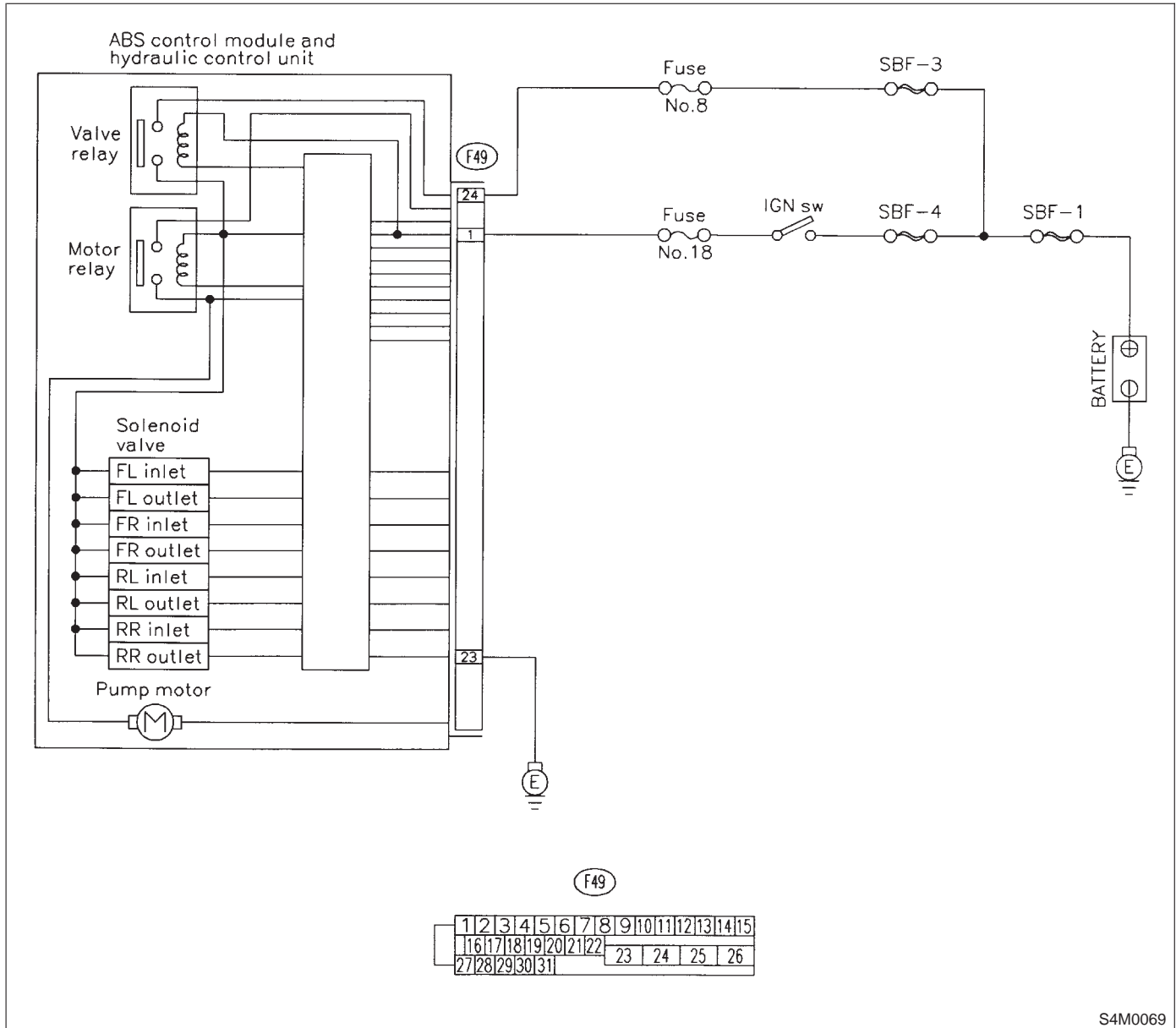

**8V1 : CHECK INPUT VOLTAGE OF ABSCM&H/U.**

- 1) Turn ignition switch to OFF.
- 2) Disconnect connector from ABSCM&H/U.
- 3) Run the engine at idle.
- 4) Measure voltage between ABSCM&H/U connector and chassis ground.

**Connector & terminal**

(F49) No. 1 (+) — Chassis ground (-):  
 (F49) No. 24 (+) — Chassis ground (-):

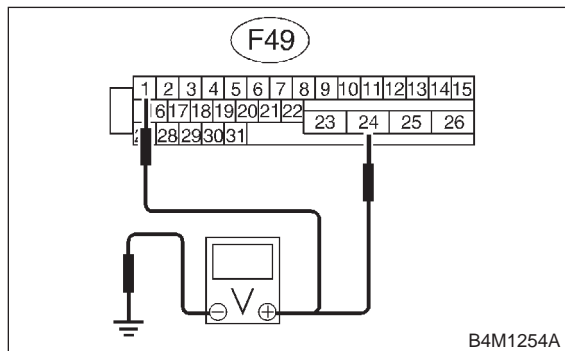

- CHECK** : Is the voltage between 10 and 15 V?
- YES** : Go to step 8V2.
- NO** : Repair harness connector between battery and ABSCM&H/U.

**8V2 : CHECK GROUND CIRCUIT OF ABSCM&H/U.**

- 1) Turn ignition switch to OFF.
- 2) Measure resistance between ABSCM&H/U connector and chassis ground.

**Connector & terminal**

(F49) No. 23 — Chassis ground:

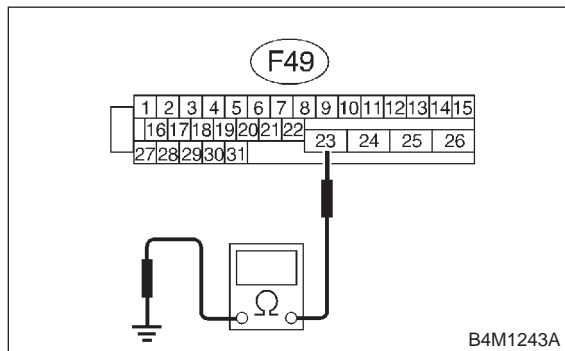

- CHECK** : Is the resistance less than 0.5 Ω?
- YES** : Go to step 8V3.
- NO** : Repair ABSCM&H/U ground harness.

**8V3 : CHECK VALVE RELAY IN ABSCM&H/U.**

Measure resistance between ABSCM&H/U and terminals.

**Terminals**

No. 23 (+) — No. 24 (-):

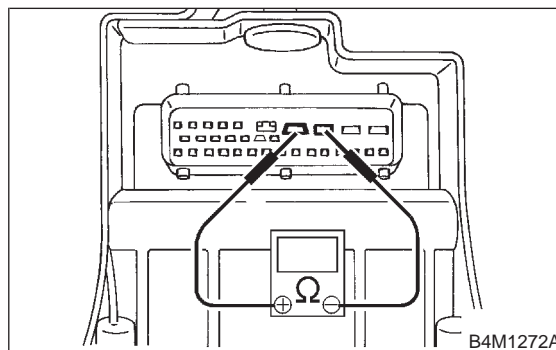

- CHECK** : Is the resistance more than 1 MΩ?
- YES** : Go to step 8V4.
- NO** : Replace ABSCM&H/U. <Ref. to 4-4 [W14A0].>

**8V4 : CHECK POOR CONTACT IN CONNECTORS.**

- CHECK** : Is there poor contact in connectors between generator, battery and ABSCM&H/U? <Ref. to FOREWORD [W3C1]. >
- YES** : Repair connector.
- NO** : Go to step 8V5.

**8V5 : CHECK ABSCM&H/U.**

- 1) Connect all connectors.
- 2) Erase the memory.
- 3) Perform inspection mode.
- 4) Read out the trouble code.

- CHECK** : Is the same trouble code as in the current diagnosis still being output?
- YES** : Replace ABSCM&H/U. <Ref. to 4-4 [W14A0].>
- NO** : Go to step 8V6.

**8V6 : CHECK ANY OTHER TROUBLE CODES APPEARANCE.**

- CHECK** : *Are other trouble codes being output?*
- YES** : Proceed with the diagnosis corresponding to the trouble code.
- NO** : A temporary poor contact.



**MEMO:**

**W: TROUBLE CODE 52**  
**— ABNORMAL MOTOR AND/OR MOTOR RELAY —**

**DIAGNOSIS:**

- Faulty motor
- Faulty motor relay
- Faulty harness connector

**TROUBLE SYMPTOM:**

- ABS does not operate.

**WIRING DIAGRAM:**

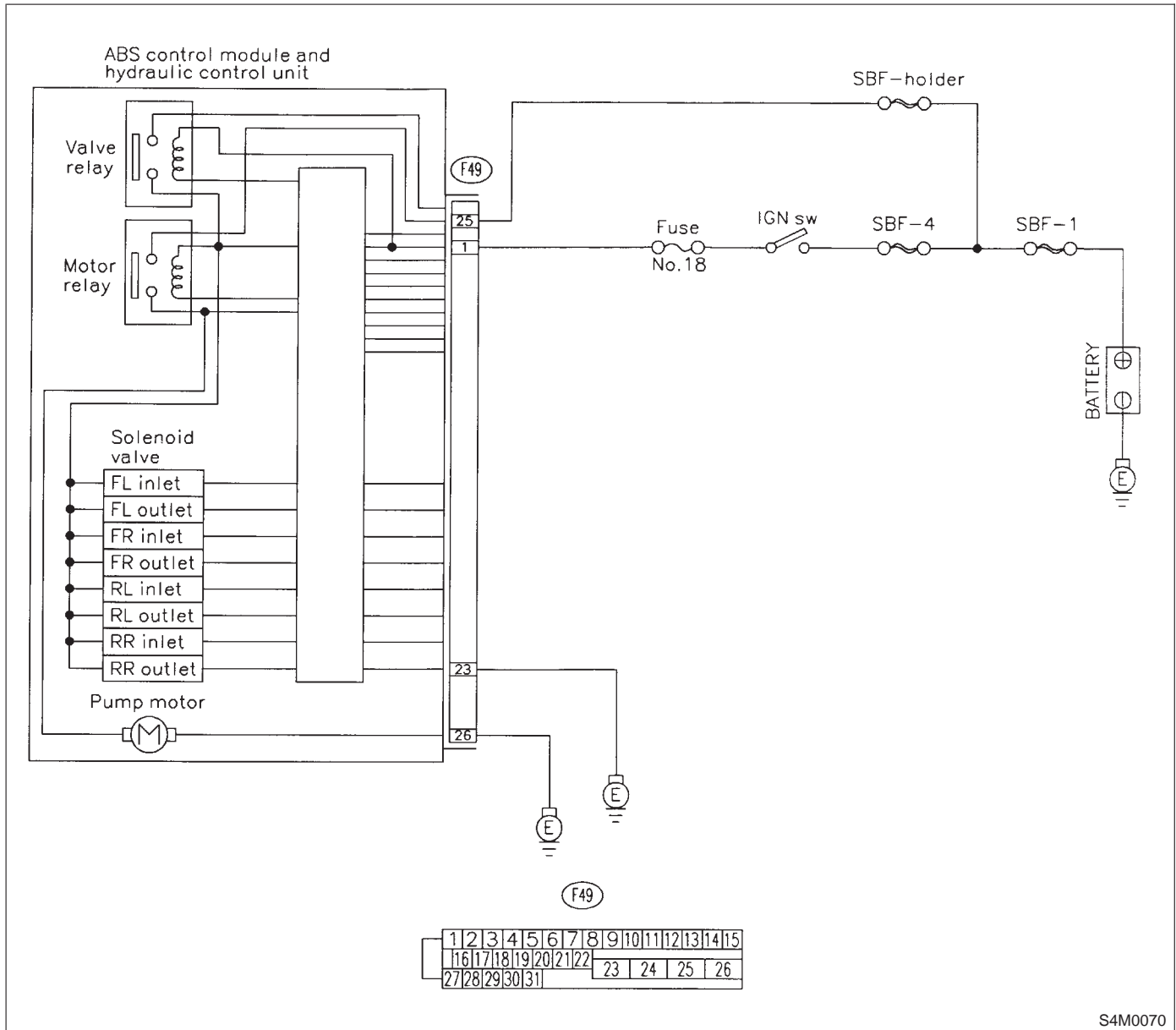

S4M0070

**8W1 : CHECK INPUT VOLTAGE OF ABSCM&H/U.**

- 1) Turn ignition switch to OFF.
- 2) Disconnect connector from ABSCM&H/U.
- 3) Turn ignition switch to ON.
- 4) Measure voltage between ABSCM&H/U connector and chassis ground.

**Connector & terminal**  
**(F49) No. 25 (+) — Chassis ground (-):**

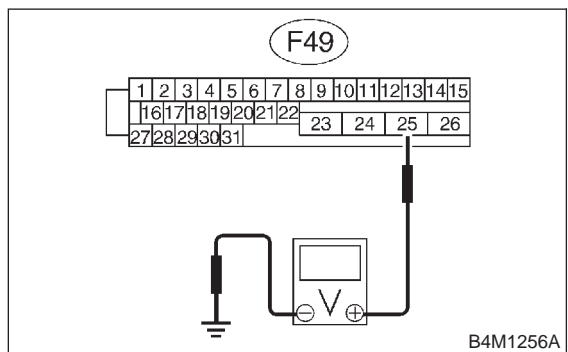

- CHECK** : Is the voltage between 10 and 15 V?
- YES** : Go to step 8W2.
- NO** : Repair harness/connector between battery and ABSCM&H/U and check fuse SBF-holder.

**8W2 : CHECK GROUND CIRCUIT OF MOTOR.**

- 1) Turn ignition switch to OFF.
- 2) Measure resistance between ABSCM&H/U connector and chassis ground.

**Connector & terminal**  
**(F49) No. 26 — Chassis ground:**

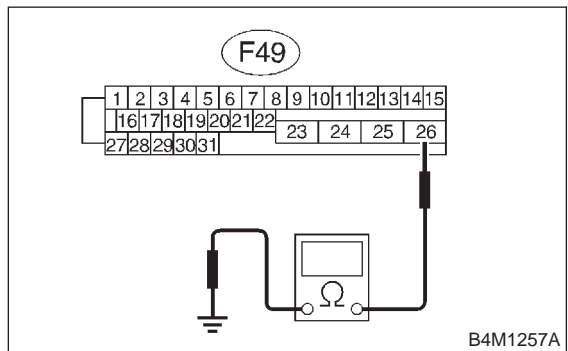

- CHECK** : Is the resistance less than 0.5 Ω?
- YES** : Go to step 8W3.
- NO** : Repair ABSCM&H/U ground harness.

**8W3 : CHECK INPUT VOLTAGE OF ABSCM&H/U.**

- 1) Run the engine at idle.
- 2) Measure voltage between ABSCM&H/U connector and chassis ground.

**Connector & terminal**  
**(F49) No. 1 (+) — Chassis ground (-):**

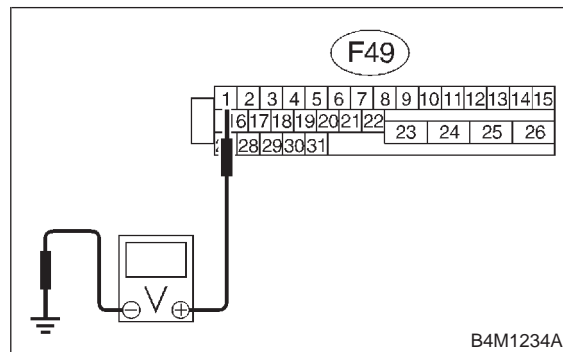

- CHECK** : Is the voltage between 10 and 15 V?
- YES** : Go to step 8W4.
- NO** : Repair harness connector between battery, ignition switch and ABSCM&H/U.

**8W4 : CHECK GROUND CIRCUIT OF ABSCM&H/U.**

- 1) Turn ignition switch to OFF.
- 2) Measure resistance between ABSCM&H/U connector and chassis ground.

**Connector & terminal**  
**(F49) No. 23 — Chassis ground:**

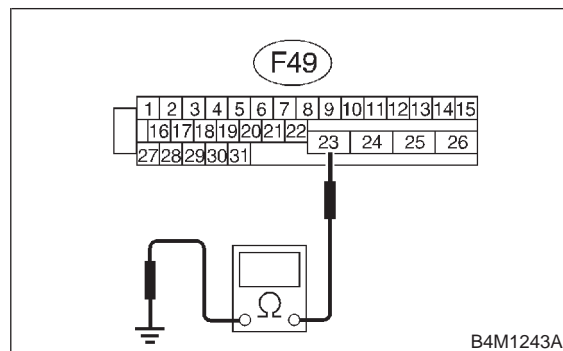

- CHECK** : Is the resistance less than 0.5 Ω?
- YES** : Go to step 8W5.
- NO** : Repair ABSCM&H/U ground harness.

**8W5 : CHECK MOTOR OPERATION.**

Operate the sequence control. <Ref. to 4-4 [W14D1].>

NOTE:

Use the diagnosis connector to operate the sequence control.

**CHECK** : *Can motor revolution noise (buzz) be heard when carrying out the sequence control?*

**YES** : Go to step **8W6**.

**NO** : Replace ABSCM&H/U. <Ref. to 4-4 [W14A0].>

**8W6 : CHECK POOR CONTACT IN CONNECTORS.**

Turn ignition switch to OFF.

**CHECK** : *Is there poor contact in connector between generator, battery and ABSCM&H/U? <Ref. to FOREWORD [W3C1]. >*

**YES** : Repair connector.

**NO** : Go to step **8W7**.

**8W7 : CHECK ABSCM&H/U.**

- 1) Connect all connectors.
- 2) Erase the memory.
- 3) Perform inspection mode.
- 4) Read out the trouble code.

**CHECK** : *Is the same trouble code as in the current diagnosis still being output?*

**YES** : Replace ABSCM&H/U. <Ref. to 4-4 [W14A0].>

**NO** : Go to step **8W8**.

**8W8 : CHECK ANY OTHER TROUBLE CODES APPEARANCE.**

**CHECK** : *Are other trouble codes being output?*

**YES** : Proceed with the diagnosis corresponding to the trouble code.

**NO** : A temporary poor contact.

**MEMO:**

**X: TROUBLE CODE 54**  
**— ABNORMAL STOP LIGHT SWITCH —**

**DIAGNOSIS:**

- Faulty stop light switch

**TROUBLE SYMPTOM:**

- ABS does not operate.

**WIRING DIAGRAM:**

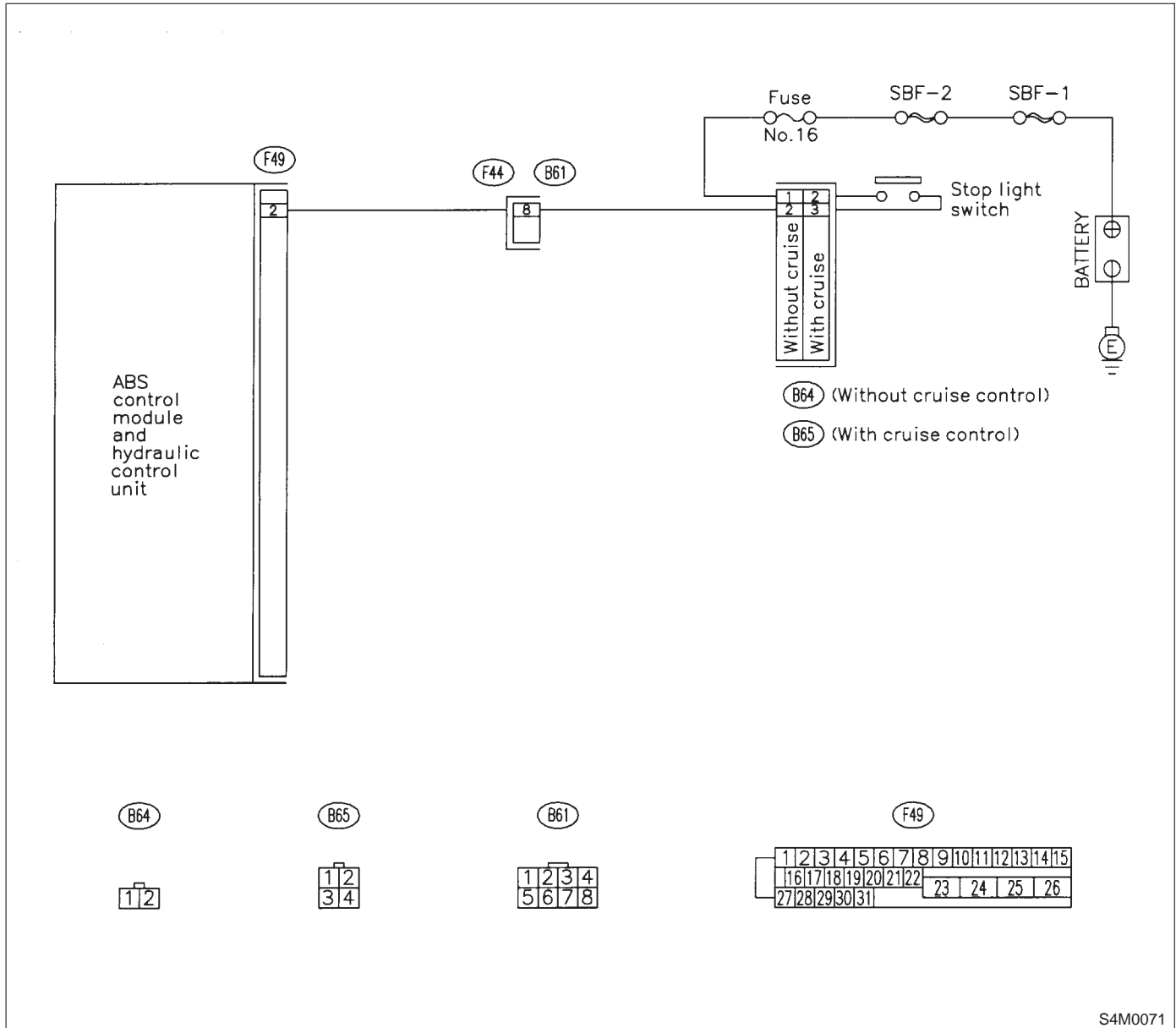

S4M0071

**8X1 : CHECK STOP LIGHTS COME ON.**

Depress the brake pedal.

- CHECK** : *Do stop lights come on?*
- YES** : Go to step **8X2**.
- NO** : Repair stop lights circuit.

**8X2 : CHECK OPEN CIRCUIT IN HARNESS.**

- 1) Turn ignition switch to OFF.
- 2) Disconnect connector from ABSCM&H/U.
- 3) Depress brake pedal.
- 4) Measure voltage between ABSCM&H/U connector and chassis ground.

**Connector & terminal**  
**(F49) No. 2 (+) — Chassis ground (-):**

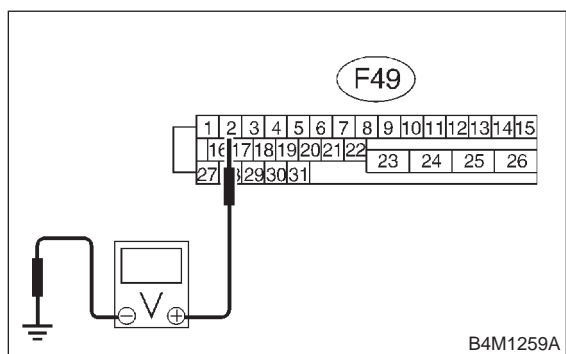

- CHECK** : *Is the voltage between 10 and 15 V?*
- YES** : Go to step **8X3**.
- NO** : Repair harness between stop light switch and ABSCM&H/U.

**8X3 : CHECK POOR CONTACT IN CONNECTORS.**

- CHECK** : *Is there poor contact in connector between stop light switch and ABSCM&H/U? <Ref. to FOREWORD [W3C1]. >*
- YES** : Repair connector.
- NO** : Go to step **8X4**.

**8X4 : CHECK ABSCM&H/U.**

- 1) Connect all connectors.
  - 2) Erase the memory.
  - 3) Perform inspection mode.
  - 4) Read out the trouble code.
- CHECK** : *Is the same trouble code as in the current diagnosis still being output?*
  - YES** : Replace ABSCM&H/U. <Ref. to 4-4 [W14A0].>
  - NO** : Go to step **8X5**.

**8X5 : CHECK ANY OTHER TROUBLE CODES APPEARANCE.**

- CHECK** : *Are other trouble codes being output?*
- YES** : Proceed with the diagnosis corresponding to the trouble code.
- NO** : A temporary poor contact.

**Y: TROUBLE CODE 56**  
**— ABNORMAL G SENSOR OUTPUT VOLTAGE —**

**DIAGNOSIS:**

- Faulty G sensor output voltage

**TROUBLE SYMPTOM:**

- ABS does not operate.

**WIRING DIAGRAM:**

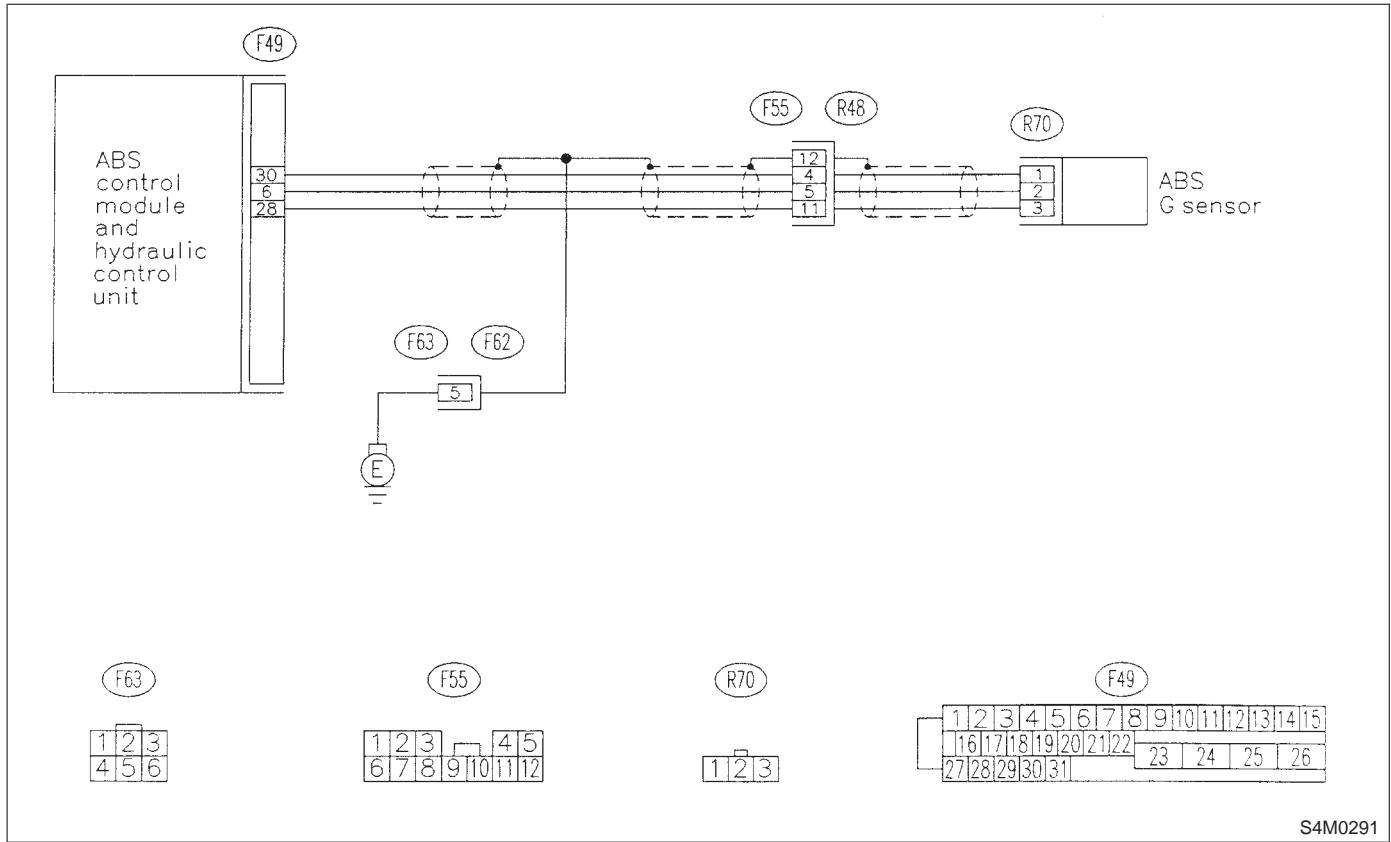

S4M0291



**8Y1 : CHECK ALL FOUR WHEELS FOR FREE TURNING.**

- CHECK** : *Have the wheels been turned freely such as when the vehicle is lifted up, or operated on a rolling road?*
- YES** : The ABS is normal. Erase the trouble code. <Ref. to 4-4 [T6D2].>
- NO** : Go to step **8Y2**.

**8Y2 : CHECK SPECIFICATIONS OF ABSCM&H/U.**

Check specifications of the mark to the ABSCM&H/U.

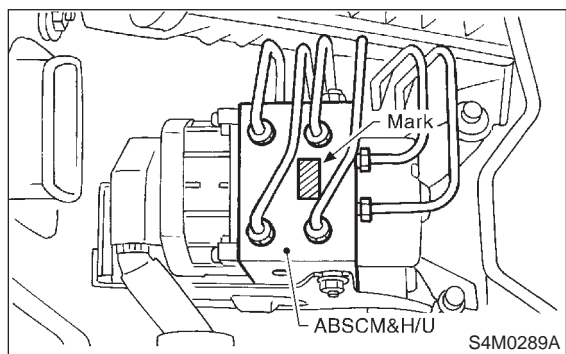

Mark	Model
C7	AWD AT
C8	AWD MT

- CHECK** : *Does the vehicle specification and the ABSCM&H/U specification match?*
- YES** : Replace ABSCM&H/U. <Ref. to 4-4 [W14A0].>

**CAUTION:**

Be sure to turn ignition switch to OFF when removing ABSCM&H/U.

- NO** : Go to step **8Y3**.

**8Y3 : CHECK INPUT VOLTAGE OF G SENSOR.**

- 1) Turn ignition switch to OFF.
- 2) Remove console box.
- 3) Disconnect G sensor from body. (Do not disconnect connector.)
- 4) Turn ignition switch to ON.
- 5) Measure voltage between G sensor connector terminals.

**Connector & terminal**

**(R70) No. 1 (+) — No. 3 (-):**

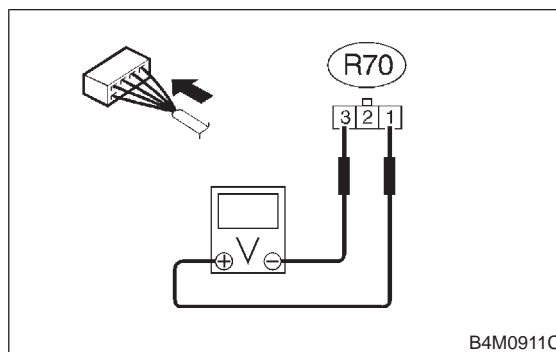

- CHECK** : *Is the voltage between 4.75 and 5.25 V?*
- YES** : Go to step **8Y4**.
- NO** : Repair harness/connector between G sensor and ABSCM&H/U.

**8Y4 : CHECK OPEN CIRCUIT IN G SENSOR OUTPUT HARNESS AND GROUND HARNESS.**

- 1) Turn ignition switch to OFF.
- 2) Disconnect connector from ABSCM&H/U.
- 3) Measure resistance between ABSCM&H/U connector terminals.

**Connector & terminal**  
(F49) No. 6 — No. 28:

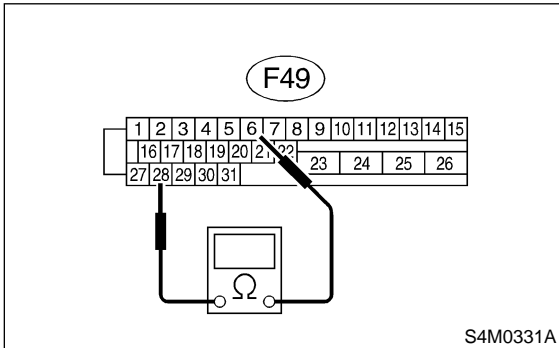

- CHECK** : Is the resistance between 4.3 and 4.9 kΩ?
- YES** : Go to step 8Y5.
- NO** : Repair harness/connector between G sensor and ABSCM&H/U.

**8Y5 : CHECK GROUND SHORT IN G SENSOR OUTPUT HARNESS.**

- 1) Disconnect connector from G sensor.
- 2) Measure resistance between ABSCM&H/U connector and chassis ground.

**Connector & terminal**  
(F49) No. 6 — Chassis ground:

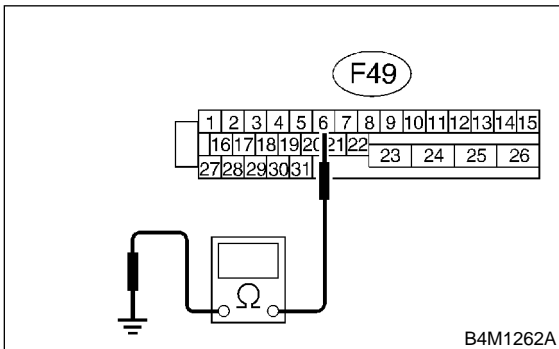

- CHECK** : Is the resistance more than 1 MΩ?
- YES** : Go to step 8Y6.
- NO** : Repair harness between G sensor and ABSCM&H/U.

**8Y6 : CHECK BATTERY SHORT OF HARNESS.**

Measure voltage between ABSCM&H/U connector and chassis ground.

**Connector & terminal**  
(F49) No. 6 (+) — Chassis ground (-):

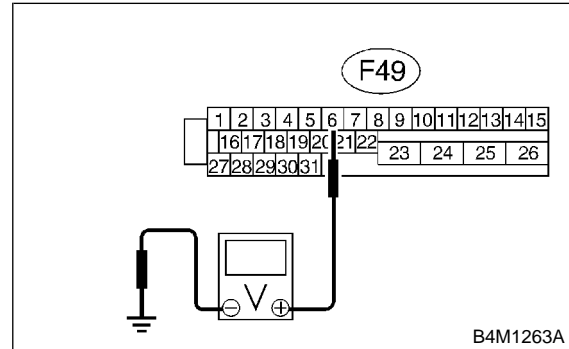

- CHECK** : Is the voltage less than 1 V?
- YES** : Go to step 8Y7.
- NO** : Repair harness between G sensor and ABSCM&H/U.

**8Y7 : CHECK BATTERY SHORT OF HARNESS.**

- 1) Turn ignition switch to ON.
- 2) Measure voltage between ABSCM&H/U connector and chassis ground.

**Connector & terminal**  
(F49) No. 6 (+) — Chassis ground (-):

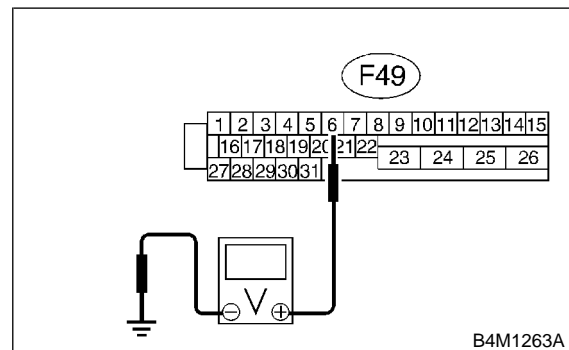

- CHECK** : Is the voltage less than 1 V?
- YES** : Go to step 8Y8.
- NO** : Repair harness between G sensor and ABSCM&H/U.

**8Y8 : CHECK GROUND SHORT OF HARNESS.**

Measure resistance between ABSCM&H/U connector and chassis ground.

**Connector & terminal**

**(F49) No. 28 — Chassis ground:**

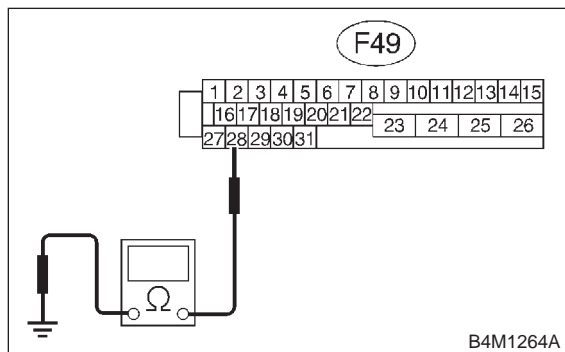

- CHECK** : *Is the resistance more than 1 MΩ?*
- YES** : Go to step **8Y9**.
- NO** : Repair harness between G sensor and ABSCM&H/U. Replace ABSCM&H/U. <Ref. to 4-4 [W14A0].>

**8Y9 : CHECK G SENSOR.**

- 1) Turn ignition switch to OFF.
- 2) Remove G sensor from vehicle.
- 3) Connect connector to G sensor.
- 4) Connect connector to ABSCM&H/U.
- 5) Turn ignition switch to ON.
- 6) Measure voltage between G sensor connector terminals.

**Connector & terminal**

**(R70) No. 2 (+) — No. 3 (-):**

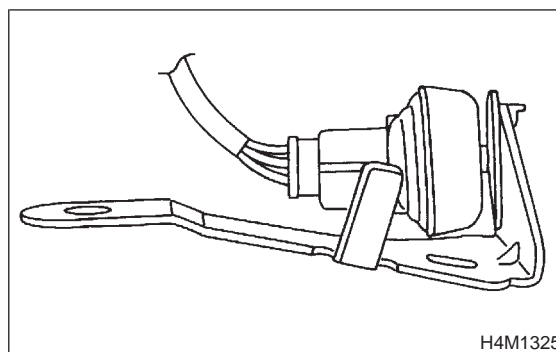
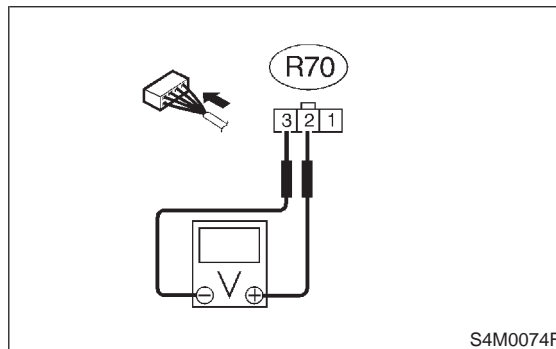

- CHECK** : *Is the voltage between 2.1 and 2.5 V when G sensor is horizontal?*
- YES** : Go to step **8Y10**.
- NO** : Replace G sensor. <Ref. to 4-4 [W15A0].>

**8Y10 : CHECK G SENSOR.**

Measure voltage between G sensor connector terminals.

**Connector & terminal**

(R70) No. 2 (+) — No. 3 (-):

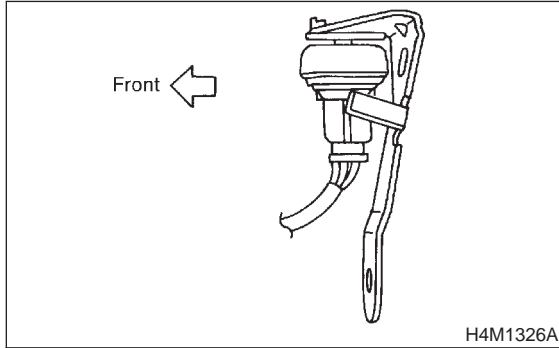

**CHECK** : *Is the voltage between 3.7 and 4.1 V when G sensor is inclined forwards to 90°?*

**YES** : Go to step 8Y11.

**NO** : Replace G sensor. <Ref. to 4-4 [W15A0].>

**8Y11 : CHECK G SENSOR.**

Measure voltage between G sensor connector terminals.

**Connector & terminal**

(R70) No. 2 (+) — No. 3 (-):

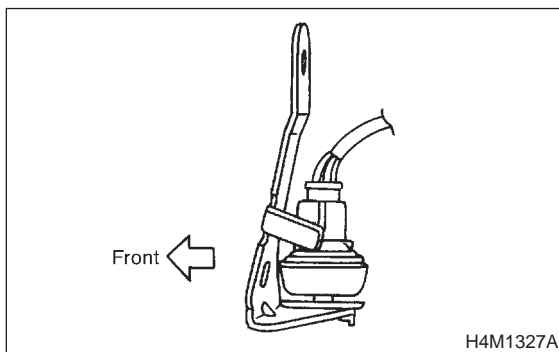

**CHECK** : *Is the voltage between 0.5 and 0.9 V when G sensor is inclined backwards to 90°?*

**YES** : Go to step 8Y12.

**NO** : Replace G sensor. <Ref. to 4-4 [W15A0].>

**8Y12 : CHECK POOR CONTACT IN CONNECTORS.**

**CHECK** : *Is there poor contact in connector between ABSCM&H/U and G sensor? <Ref. to FOREWORD [W3C1]. >*

**YES** : Repair connector.

**NO** : Go to step 8Y13.

**8Y13 : CHECK ABSCM&H/U.**

- 1) Connect all connectors.
- 2) Erase the memory.
- 3) Perform inspection mode.
- 4) Read out the trouble code.

**CHECK** : *Is the same trouble code as in the current diagnosis still being output?*

**YES** : Replace ABSCM&H/U. <Ref. to 4-4 [W14A0].>

**NO** : Go to step 8Y14.

**8Y14 : CHECK ANY OTHER TROUBLE CODES APPEARANCE.**

**CHECK** : *Are other trouble codes being output?*

**YES** : Proceed with the diagnosis corresponding to the trouble code.

**NO** : A temporary poor contact.

**MEMO:**

## 9. Select Monitor Function Mode

Applicable cartridge of select monitor. <Ref. to 1-6 [G1100].>

### NOTE:

For basic handling of the select monitor, refer to its Operation Manual.

## A: LIST OF FUNCTION MODE

### 1. ANALOG DATA ARE DISPLAYED

Display screen	Contents to be monitored
FR wheel speed	Wheel speed detected by the Front Right ABS sensor is displayed in km/h or mile/h.
FL wheel speed	Wheel speed detected by the Front Left ABS sensor is displayed in km/h or mile/h.
RR wheel speed	Wheel speed detected by the Rear Right ABS sensor is displayed in km/h or mile/h.
RL wheel speed	Wheel speed detected by the Rear Left ABS sensor is displayed in km/h or mile/h.
Stop light switch	Stop light switch monitor voltage is displayed.
G sensor output voltage	Refers to vehicle acceleration detecting by the analog G sensor. It appears on the select monitor display in volts.

### 2. ON/OFF DATA ARE DISPLAYED

Display screen	Contents to be monitored
Stop light switch	Stop light switch signal
Valve relay signal	Valve relay signal
Motor relay signal	Motor relay signal
ABS signal to TCM	ABS operation signal from ABS control module to TCM
ABS warning light	ABS warning light
Valve relay monitor	Valve relay operation monitor signal
Motor relay monitor	Motor relay operation monitor signal
CCM signal	ABS operation signal from ABS control module to TCM (ABS operation signal monitor)

### 3. TROUBLE CODES ARE DISPLAYED

A maximum of 3 trouble codes are displayed in order of occurrence.

- If a particular trouble code is not properly stored in memory (due to a drop in ABSCM&H/U power supply, etc.) when a problem occurs, the trouble code, followed by a question mark "?", appears on the select monitor display. This shows it may be an unreliable reading.

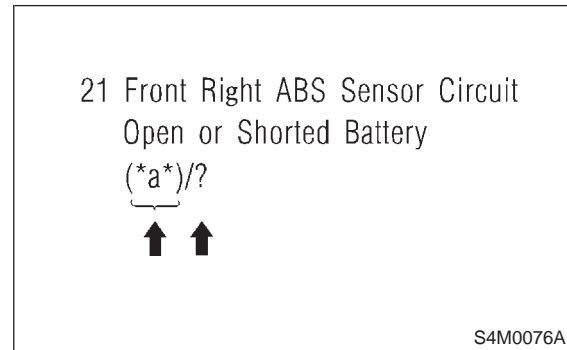

- \*a\* refers to the troubles in order of occurrence (Latest, Old, Older and Reference).

Display screen	Contents to be monitored
Latest	The most recent trouble code appears on the select monitor display.
Old	The second most recent trouble code appears on the select monitor display.
Older	The third most recent trouble code appears on the select monitor display.
Reference	A specified period of time proceeding trouble code appears on the select monitor display.

### 4. CLEAR MEMORY

Display screen	Contents to be monitored
Clear memory?	Function of clearing trouble code and freeze frame data.

### 5. ABS SEQUENCE CONTROL

Display screen	Contents to be monitored	Ref. to
ABS sequence control	Perform ABS sequence control by operating valve and pump motor sequentially.	<Ref. to 4-4 [W14D2].>

## 6. FREEZE FRAME DATA

**NOTE:**

- Data stored at the time of trouble occurrence is shown on display.
- Each time trouble occurs, the latest information is stored in the freeze frame data in memory.
- If freeze frame data is not properly stored in memory (due to a drop in ABSCM power supply, etc.), a freeze frame data, preceded by a question mark “?”, appears on the select monitor display. This shows it may be an unreliable reading. The value of the freeze frame data will be written over, and the memory cannot be cleared.

Display screen	Contents to be monitored
FR wheel speed	Wheel speed detected by the Front Right ABS sensor is displayed in km/h or mile/h.
FL wheel speed	Wheel speed detected by the Front Left ABS sensor is displayed in km/h or mile/h.
RR wheel speed	Wheel speed detected by the Rear Right ABS sensor is displayed in km/h or mile/h.
RL wheel speed	Wheel speed detected by the Rear Left ABS sensor is displayed in km/h or mile/h.
ABSCM power voltage	Power (in volts) supplied to ABSCM&H/U appears on the select monitor display.
G sensor output voltage	Refers to vehicle acceleration detected by the analog G sensor. It appears on the select monitor display in volts.
Motor relay monitor	Motor relay operation monitor signal
Stop light switch	Stop light switch signal
ABS signal to TCM	ABS operation signal from ABS control module to TCM (Output signal)
ABS-AT control	ABS operation signal from ABS control module to TCM (ABS operation signal monitor)
ABS operation signal	ABS operation signal

# 10. Diagnostics Chart with Select Monitor

## A: BASIC DIAGNOSTIC CHART

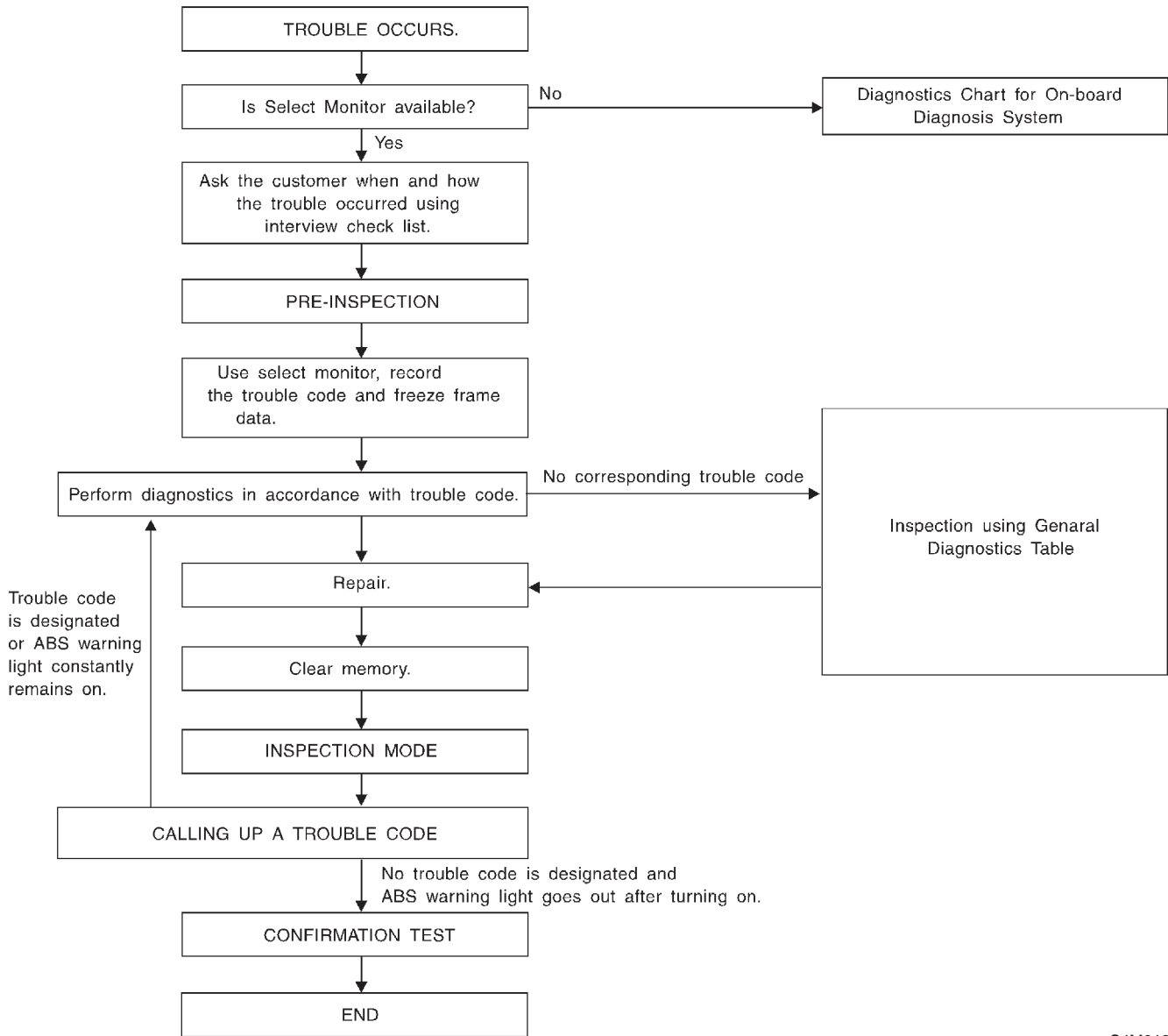

S4M0180B

**CAUTION:**

Remove foreign matter (dust, water, etc.) from the ABSCM&H/U connector during removal and installation.

**NOTE:**

To check harness for broken wires or short circuits, shake it while holding it or the connector.



**B: LIST OF DIAGNOSTIC TROUBLE CODE**

Code	Display screen	Contents of diagnosis	Ref. to
—	Communication for initializing impossible	Select monitor communication failure	<Ref. to 4-4 [T10C0].>
—	No trouble code	Although no trouble code appears on the select monitor display, the ABS warning light remains on.	<Ref. to 4-4 [T10D0].>
21	Open or short circuit in front right ABS sensor circuit	Open or short circuit in front right ABS sensor circuit	<Ref. to 4-4 [T10E0].>
22	Front right ABS sensor abnormal signal	Front right ABS sensor abnormal signal	<Ref. to 4-4 [T10I0].>
23	Open or short circuit in front left ABS sensor circuit	Open or short circuit in front left ABS sensor circuit	<Ref. to 4-4 [T10F0].>
24	Front left ABS sensor abnormal signal	Front left ABS sensor abnormal signal	<Ref. to 4-4 [T10J0].>
25	Open or short circuit in rear right ABS sensor circuit	Open or short circuit in rear right ABS sensor circuit	<Ref. to 4-4 [T10K0].>
26	Rear right ABS sensor abnormal signal	Rear right ABS sensor abnormal signal	<Ref. to 4-4 [T10C0].>
27	Open or short circuit in rear left ABS sensor circuit	Open or short circuit in rear left ABS sensor circuit	<Ref. to 4-4 [T10H0].>
28	Rear left ABS sensor abnormal signal	Rear left ABS sensor abnormal signal	<Ref. to 4-4 [T10L0].>
29	Abnormal ABS sensor signal on any one of four sensor	Abnormal ABS sensor signal on any one of four	<Ref. to 4-4 [T10M0].>
31	Front right inlet valve malfunction	Front right inlet valve malfunction	<Ref. to 4-4 [T10N0].>
32	Front right outlet valve malfunction	Front right outlet valve malfunction	<Ref. to 4-4 [T10R0].>
33	Front left inlet valve malfunction	Front left inlet valve malfunction	<Ref. to 4-4 [T10O0].>
34	Front left outlet valve malfunction	Front left outlet valve malfunction	<Ref. to 4-4 [T10S0].>
35	Rear right inlet valve malfunction	Rear right inlet valve malfunction	<Ref. to 4-4 [T10P0].>
36	Rear right outlet valve malfunction	Rear right outlet valve malfunction	<Ref. to 4-4 [T10T0].>
37	Rear left inlet valve malfunction	Rear left inlet valve malfunction	<Ref. to 4-4 [T10Q0].>
38	Rear left outlet valve malfunction	Rear left outlet valve malfunction	<Ref. to 4-4 [T10U0].>
41	ABS control module malfunction	ABS control module and hydraulic control unit malfunction	<Ref. to 4-4 [T10V0].>
42	Power supply voltage too low	Power supply voltage too low	<Ref. to 4-4 [T10W0].>
42	Power supply voltage too high	Power supply voltage too high	<Ref. to 4-4 [T10X0].>
44	ABS-AT control (Non Controlled)	ABS-AT control (Non Controlled)	<Ref. to 4-4 [T10Y0].>
44	ABS-AT control (Controlled)	ABS-AT control (Controlled)	<Ref. to 4-4 [T10Z0].>
51	Valve relay malfunction	Valve relay malfunction	<Ref. to 4-4 [T10AA0].>
51	Valve relay ON failure	Valve relay ON failure	<Ref. to 4-4 [T10AB0].>
52	Open circuit in motor relay circuit	Open circuit in motor relay circuit	<Ref. to 4-4 [T10AC0].>
52	Motor relay ON failure	Motor relay ON failure	<Ref. to 4-4 [T10AD0].>
52	Motor malfunction	Motor malfunction	<Ref. to 4-4 [T10AE0].>
54	Stop light switch signal circuit malfunction	Stop light switch signal circuit malfunction	<Ref. to 4-4 [T10AF0].>
56	Open or short circuit in G sensor circuit	Open or short circuit in G sensor circuit	<Ref. to 4-4 [T10AG0].>
56	Battery short in G sensor circuit	Battery short in G sensor circuit	<Ref. to 4-4 [T10AH0].>
56	Abnormal G sensor high $\mu$ output	Abnormal G sensor high $\mu$ output	<Ref. to 4-4 [T10AI0].>
56	Detection of G sensor stick	Detection of G sensor stick	<Ref. to 4-4 [T10AJ0].>

**NOTE:**

High  $\mu$  means high friction coefficient against road surface.

**C: COMMUNICATION FOR INITIALIZING IMPOSSIBLE  
— SELECT MONITOR COMMUNICATION FAILURE —**

**DIAGNOSIS:**

- Faulty harness connector

**TROUBLE SYMPTOM:**

- ABS warning light remains on.

**WIRING DIAGRAM:**

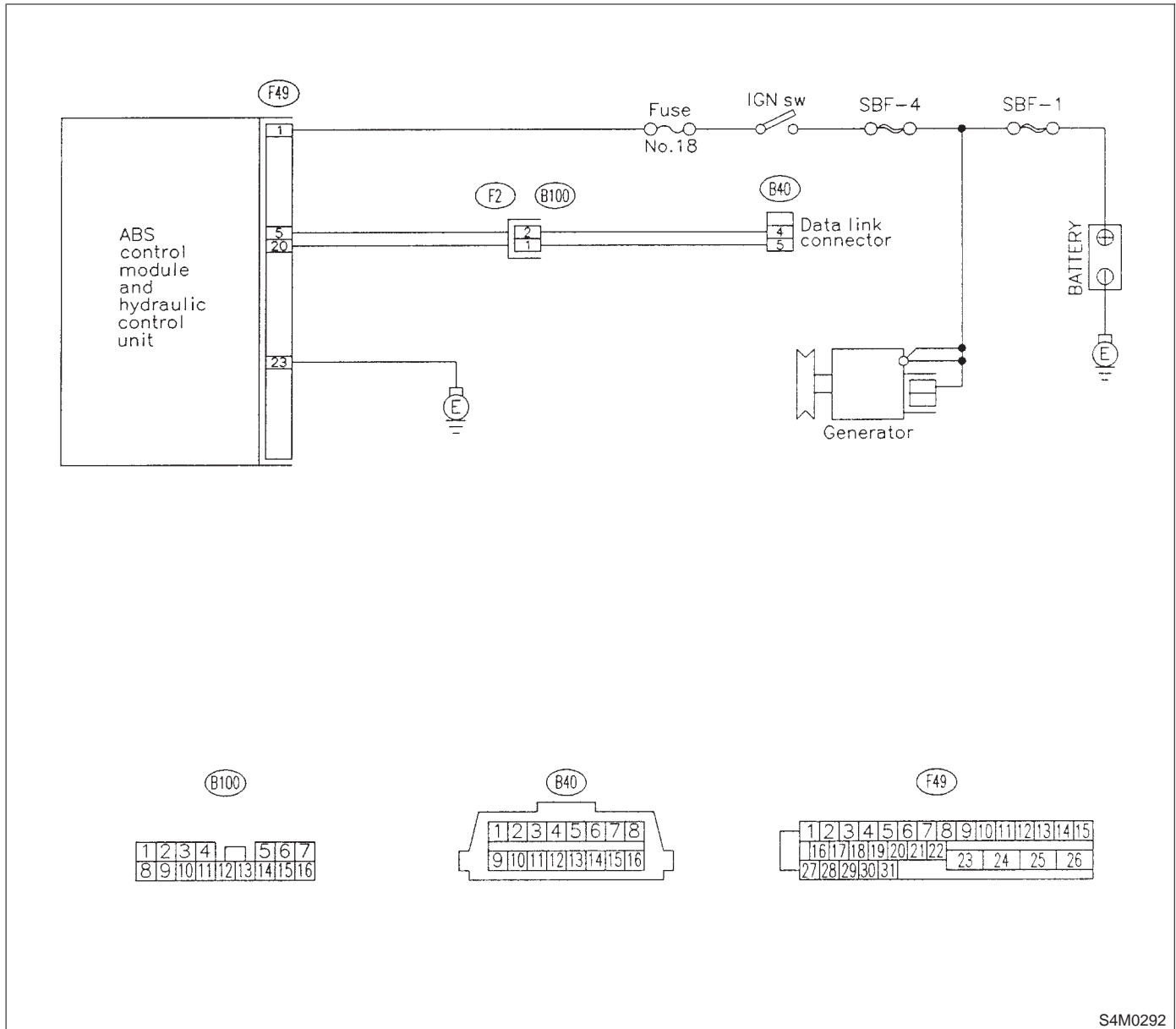

S4M0292

**10C1 : CHECK IGNITION SWITCH.**

- CHECK** : *Is ignition switch ON?*
- YES** : Go to step **10C2**.
- NO** : Turn ignition switch to ON, and select brake control mode using the select monitor.

**10C2 : CHECK GENERATOR.**

- 1) Start the engine.
- 2) Idle the engine.
- 3) Measure voltage between generator and chassis ground.

**Terminals**

**Generator B terminal (+) — Chassis ground (-):**

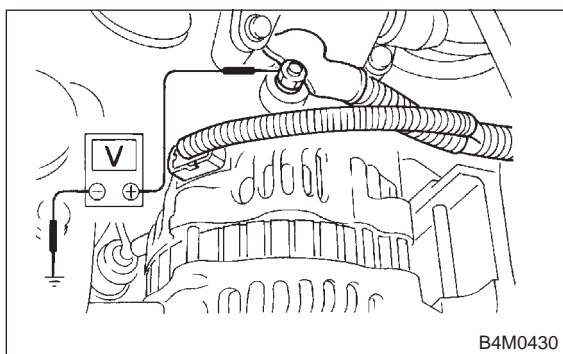

- CHECK** : *Is the voltage between 10 and 15 V?*
- YES** : Go to step **10C3**.
- NO** : Repair generator. <Ref. to 6-1 [W2A0].>

**10C3 : CHECK BATTERY TERMINAL.**

Turn ignition switch to OFF.

- CHECK** : *Is there poor contact at battery terminal?*
- YES** : Repair battery terminal.
- NO** : Go to step **10C4**.

**10C4 : CHECK COMMUNICATION OF SELECT MONITOR.**

Using the select monitor, check whether communication to other system (such as engine, AT, etc.) can be executed normally.

- CHECK** : *Are the name and year of the system displayed on the select monitor?*
- YES** : Go to step **10C5**.
- NO** : Repair select monitor communication cable and connector.

**10C5 : CHECK INSTALLATION OF ABSCM&H/U CONNECTOR.**

Turn ignition switch to OFF.

- CHECK** : *Is ABSCM&H/U connector inserted into ABSCM&H/U until the clamp locks onto it?*
- YES** : Go to step **10C6**.
- NO** : Insert ABSCM&H/U connector into ABSCM&H/U until the clamp locks onto it.

**10C6 : CHECK POWER SUPPLY OF ABSCM&H/U.**

- 1) Disconnect connector from ABSCM&H/U.
- 2) Start engine.
- 3) Idle the engine.
- 4) Measure voltage between ABSCM&H/U connector and chassis ground.

**Connector & terminal**

**(F49) No. 1 (+) — Chassis ground (-):**

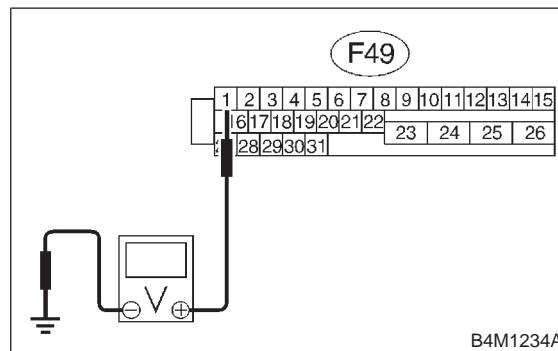

- CHECK** : *Is the voltage between 10 and 15 V?*
- YES** : Go to step **10C7**.
- NO** : Repair ABSCM&H/U power supply circuit.

**10C7 : CHECK GROUND CIRCUIT OF ABSCM&H/U.**

- 1) Turn ignition switch to OFF.
- 2) Measure resistance between ABSCM&H/U connector and chassis ground.

**Connector & terminal**

**(F49) No. 23 — Chassis ground:**

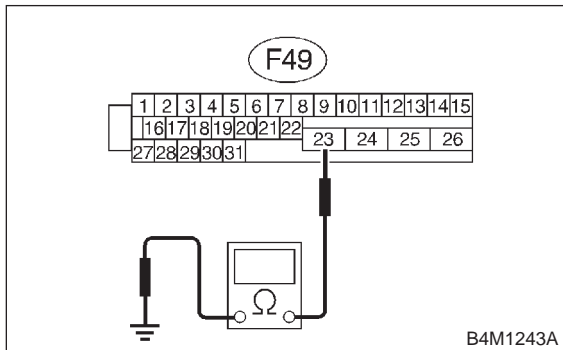

- CHECK** : *Is the resistance less than 0.5 Ω?*
- YES** : Repair harness/connector between ABSCM&H/U and select monitor.
- NO** : Go to step **10C8**.

**10C8 : CHECK HARNESS/CONNECTOR BETWEEN ABSCM&H/U AND DATA LINK CONNECTOR.**

- 1) Turn ignition switch to OFF.
- 2) Measure resistance between ABSCM&H/U connector and data link connector.

**Connector & terminal**

**(F49) No. 20 — (B40) No. 5:**

**(F49) No. 5 — (B40) No. 4:**

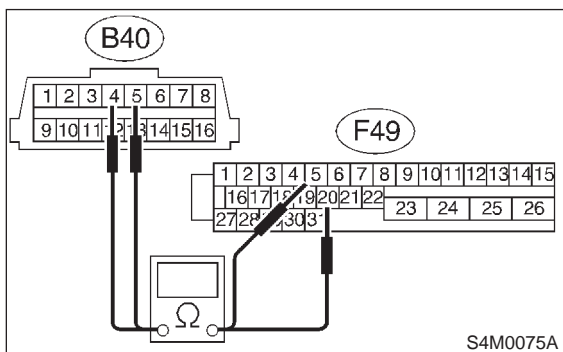

- CHECK** : *Is the resistance less than 0.5 Ω?*
- YES** : Repair harness and connector between ABSCM&H/U and data link connector.
- NO** : Go to step **10C9**.

**10C9 : CHECK POOR CONTACT IN CONNECTORS.**

- CHECK** : *Is there poor contact in connectors between ABSCM&H/U and data link connector? <Ref. to FOREWORD [W3C1].>*
- YES** : Repair connector.
- NO** : Replace ABSCM&H/U. <Ref. to 4-4 [W14A0].>

**MEMO:**

**D: NO TROUBLE CODE**

**— ALTHOUGH NO TROUBLE CODE APPEARS ON THE SELECT MONITOR DISPLAY, THE ABS WARNING LIGHT REMAINS ON. —**

**DIAGNOSIS:**

- ABS warning light circuit is shorted.

**TROUBLE SYMPTOM:**

- ABS warning light remains on.
- NO TROUBLE CODE displayed on the select monitor.

**NOTE:**

When the ABS warning light is OFF and "NO TROUBLE CODE" is displayed on the select monitor, the system is in normal condition.

**WIRING DIAGRAM:**

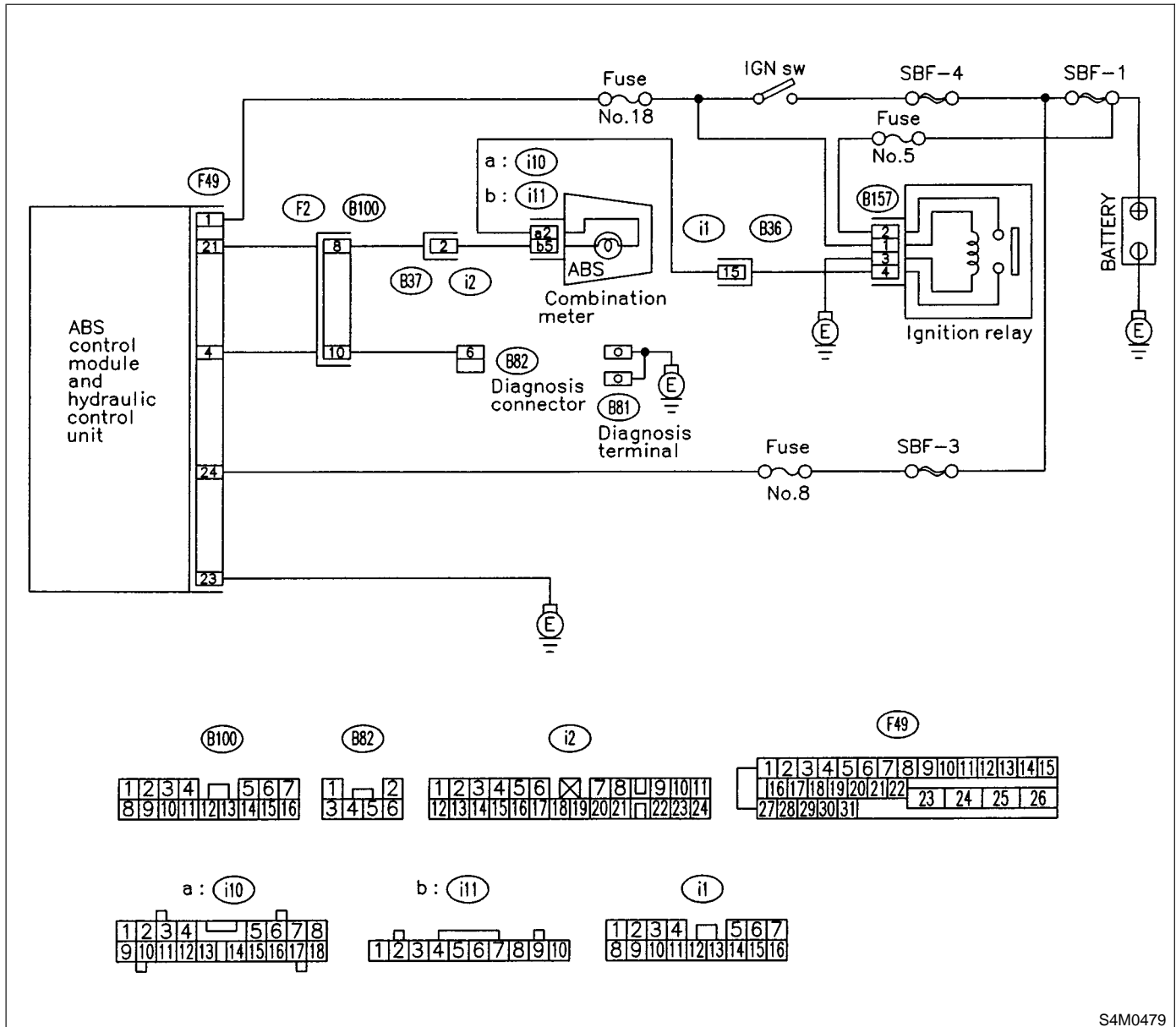

**10D1 : CHECK WIRING HARNESS.**

- 1) Turn ignition switch to OFF.
- 2) Disconnect connector (F2) from connector (B100).
- 3) Turn ignition switch to ON.

- CHECK** : Does the ABS warning light remain off?
- YES** : Go to step 10D2.
- NO** : Repair front wiring harness.

**10D2 : CHECK PROJECTION AT ABSCM&H/U.**

- 1) Turn ignition switch to OFF.
- 2) Disconnect connector from ABSCM&H/U.
- 3) Check for broken projection at the ABSCM&H/U terminal.

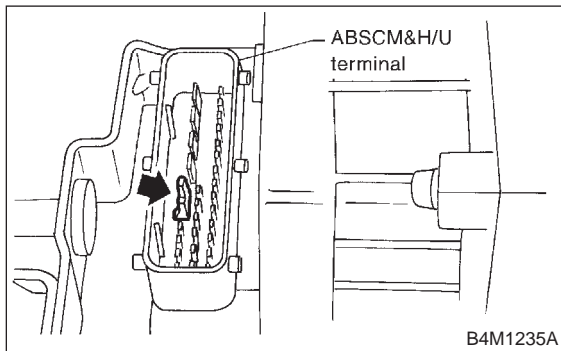

- CHECK** : Are the projection broken?
- YES** : Replace ABSCM&H/U. <Ref. to 4-4 [W14A0].>
- NO** : Go to step 10D3.

**10D3 : CHECK ABSCM&H/U.**

Measure resistance between ABSCM&H/U terminals.

**Terminals**  
No. 21 — No. 23:

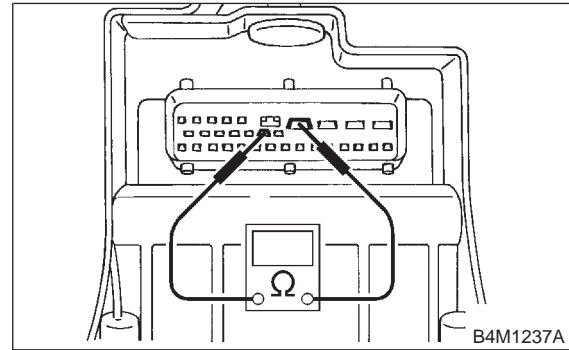

- CHECK** : Is the resistance more than 1 MΩ?
- YES** : Go to step 10D4.
- NO** : Replace ABSCM&H/U. <Ref. to 4-4 [W14A0].>

**10D4 : CHECK WIRING HARNESS.**

Measure resistance between connector (F2) and chassis ground.

**Connector & terminal**  
(F2) No. 8 — Chassis ground:

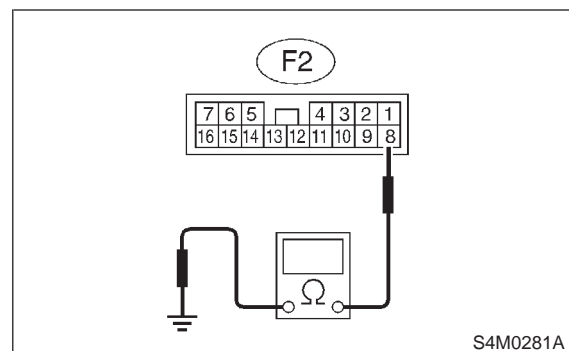

- CHECK** : Is the resistance less than 0.5 Ω?
- YES** : Go to step 10D5.
- NO** : Repair harness.

**10D5 : CHECK WIRING HARNESS.**

- 1) Connect connector to ABSCM&H/U.
- 2) Measure resistance between connector (F2) and chassis ground.

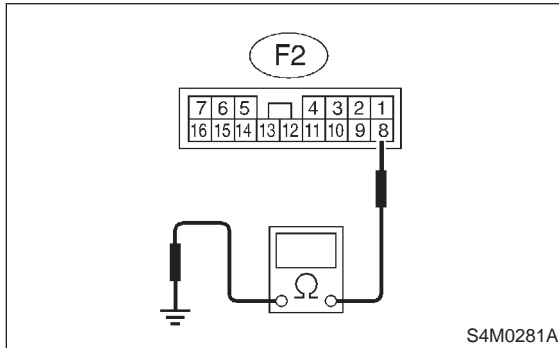
**Connector & terminal****(F2) No. 8 — Chassis ground:**

- CHECK** : *Is the resistance more than 1 MΩ?*
- YES** : Go to step **10D6**.
- NO** : Repair harness.

**10D6 : CHECK POOR CONTACT IN ABSCM&H/U CONNECTOR.**

- CHECK** : *Is there poor contact in ABSCM&H/U connector? <Ref. to FOREWORD [W3C1].>*
- YES** : Repair connector.
- NO** : Replace ABSCM&H/U. <Ref. to 4-4 [W14A0].>



**MEMO:**

**E: TROUBLE CODE 21 OPEN OR SHORT CIRCUIT IN FRONT RIGHT ABS SENSOR CIRCUIT**

**F: TROUBLE CODE 23 OPEN OR SHORT CIRCUIT IN FRONT LEFT ABS SENSOR CIRCUIT**

**G: TROUBLE CODE 25 OPEN OR SHORT CIRCUIT IN REAR RIGHT ABS SENSOR CIRCUIT**

**H: TROUBLE CODE 27 OPEN OR SHORT CIRCUIT IN REAR LEFT ABS SENSOR CIRCUIT**

**— ABNORMAL ABS SENSOR (OPEN OR SHORT CIRCUIT IN ABS SENSOR CIRCUIT) —**

**DIAGNOSIS:**

- Faulty ABS sensor (Broken wire, input voltage too high)
- Faulty harness connector

**TROUBLE SYMPTOM:**

- ABS does not operate.

WIRING DIAGRAM:

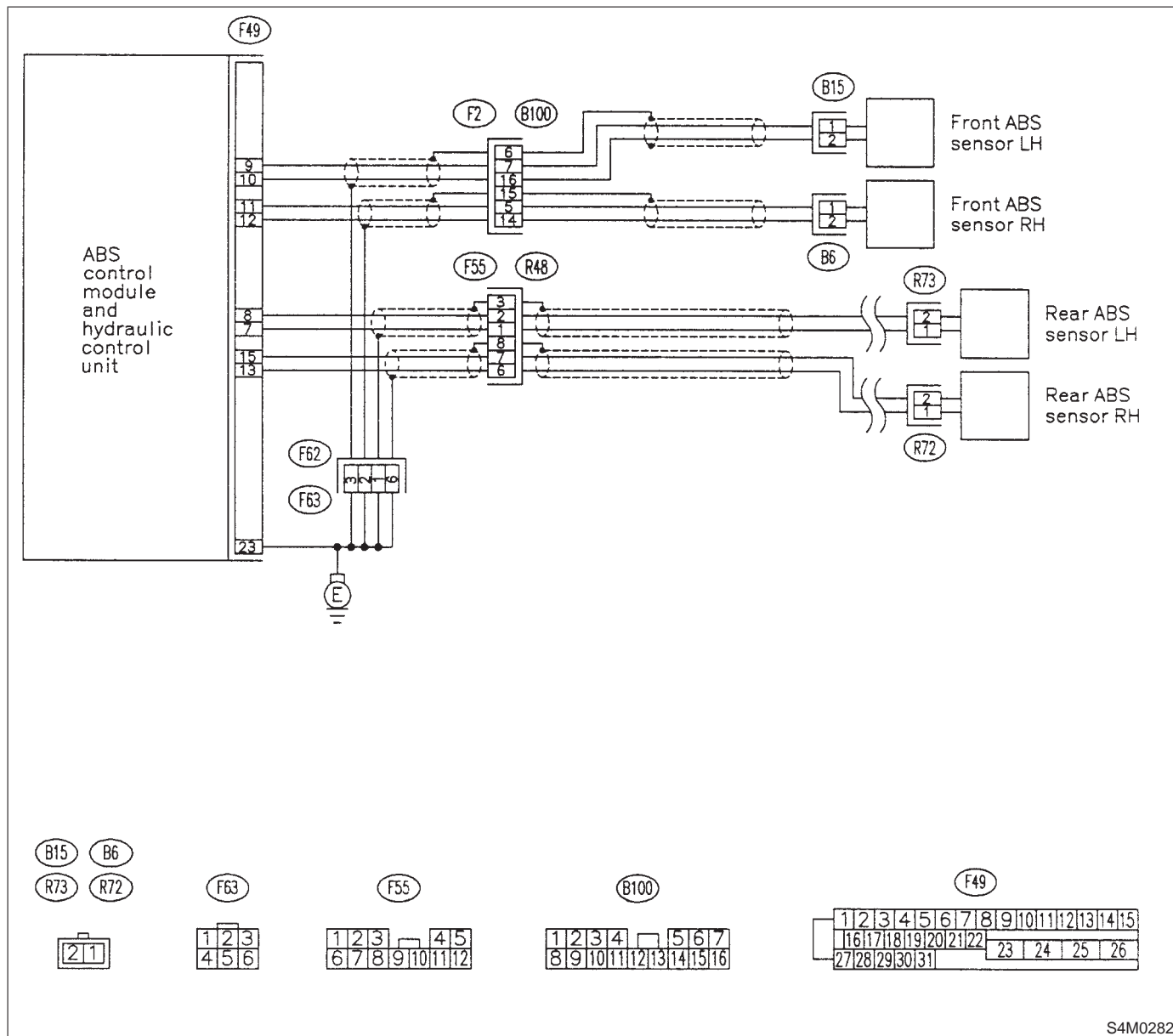

S4M0282

### 10H1 : CHECK OUTPUT OF ABS SENSOR USING SELECT MONITOR.

- 1) Select "Current data display & Save" on the select monitor.
- 2) Read the ABS sensor output corresponding to the faulty system in the select monitor data display mode.

**CHECK** : Does the speed indicated on the display change in response to the speedometer reading during acceleration/deceleration when the steering wheel is in the straight-ahead position?

**YES** : Go to step 10H2.

**NO** : Go to step 10H10.

### 10H2 : CHECK INSTALLATION OF ABS SENSOR.

#### Tightening torque:

$32 \pm 10 \text{ N}\cdot\text{m}$  ( $3.3 \pm 1.0 \text{ kg}\cdot\text{m}$ ,  $24 \pm 7 \text{ ft}\cdot\text{lb}$ )

**CHECK** : Are the ABS sensor installation bolts tightened securely?

**YES** : Go to step 10H3.

**NO** : Tighten ABS sensor installation bolts securely.

### 10H3 : CHECK TROUBLE CODE.

**CHECK** : Is the trouble code 21 and/or 23?

**YES** : Go to step 10H5.

**NO** : Go to step 10H4.

### 10H4 : CHECK INSTALLATION OF REAR TONE WHEEL.

#### Tightening torque:

$13 \pm 3 \text{ N}\cdot\text{m}$  ( $1.3 \pm 0.3 \text{ kg}\cdot\text{m}$ ,  $9 \pm 2.2 \text{ ft}\cdot\text{lb}$ )

**CHECK** : Are the rear tone wheel installation bolts tightened securely?

**YES** : Go to step 10H5.

**NO** : Tighten rear tone wheel installation bolts securely.

### 10H5 : CHECK ABS SENSOR GAP.

Measure tone wheel-to-pole piece gap over entire perimeter of the wheel. <Ref. to 4-4 [W13C0].>

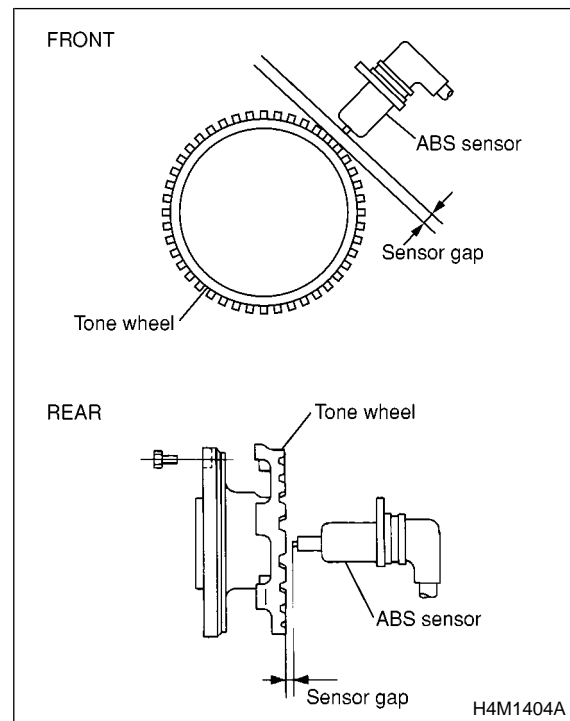

	Front wheel	Rear wheel
Specifications	0.3 — 0.8 mm (0.012 — 0.031 in)	0.7 — 1.2 mm (0.028 — 0.047 in)

**CHECK** : Is the gap within the specifications?

**YES** : Go to step 10H6.

**NO** : Adjust the gap.

#### NOTE:

Adjust the gap using spacers (Part No. 26755AA000). If spacers cannot correct the gap, replace worn sensor or worn tone wheel.

### 10H6 : CHECK HUB RUNOUT.

Measure hub runout.

**CHECK** : Is the runout less than 0.05 mm (0.0020 in)?

**YES** : Go to step 10H7.

**NO** : Repair hub.

**10H7 : CHECK POOR CONTACT IN CONNECTORS.**

Turn ignition switch to OFF.

**CHECK** : *Is there poor contact in connectors between ABSCM&H/U and ABS sensor? <Ref. to FOREWORD [W3C1].>*

**YES** : Repair connector.

**NO** : Go to step 10H8.

**10H8 : CHECK ABSCM&H/U.**

- 1) Connect all connectors.
- 2) Erase the memory.
- 3) Perform inspection mode.
- 4) Read out the trouble code.

**CHECK** : *Is the same trouble code as in the current diagnosis still being output?*

**YES** : Replace ABSCM&H/U. <Ref. to 4-4 [W14A0].>

**NO** : Go to step 10H9.

**10H9 : CHECK ANY OTHER TROUBLE CODES APPEARANCE.**

**CHECK** : *Are other trouble codes being output?*

**YES** : Proceed with the diagnosis corresponding to the trouble code.

**NO** : A temporary poor contact.

NOTE:

Check harness and connectors between ABSCM&H/U and ABS sensor.

**10H10 : CHECK FRONT ABS SENSOR.**

- 1) Turn ignition switch to OFF.
- 2) Disconnect connector from front ABS sensor.
- 3) Measure resistance of front ABS sensor connector terminals.

**Terminals**

**RH No. 1 — No. 2:**

**LH No. 1 — No. 2:**

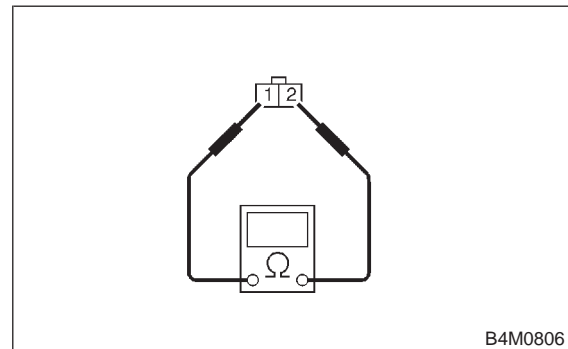

**CHECK** : *Is the resistance between 1.0 and 1.5 kΩ?*

**YES** : Go to step 10H11.

**NO** : Replace front ABS sensor.

**10H11 : CHECK REAR ABS SENSOR.**

- 1) Turn ignition switch to OFF.
- 2) Disconnect connector from rear ABS sensor.
- 3) Measure resistance of rear ABS sensor connector terminals.

**Terminals**

**RH No. 1 — No. 2:**

**LH No. 1 — No. 2:**

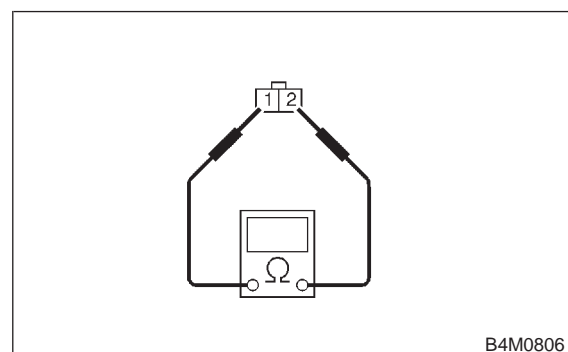

**CHECK** : *Is the resistance between 0.8 and 1.2 kΩ?*

**YES** : Go to step 10H12.

**NO** : Replace rear ABS sensor.

**10H12 : CHECK BATTERY SHORT OF ABS SENSOR.**

- 1) Disconnect connector from ABSCM&H/U.
- 2) Measure voltage between ABS sensor and chassis ground.

**Terminals**

- Front RH No. 1 (+) — Chassis ground (-):
- Front LH No. 1 (+) — Chassis ground (-):
- Rear RH No. 1 (+) — Chassis ground (-):
- Rear LH No. 1 (+) — Chassis ground (-):

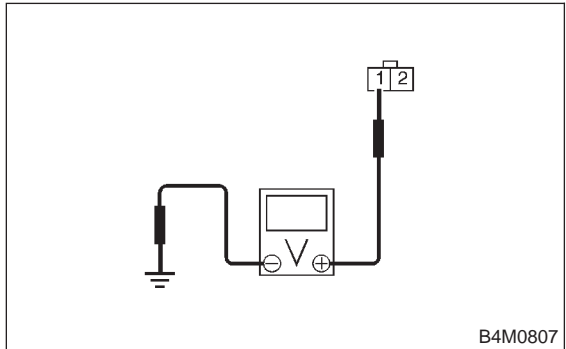

- CHECK** : Is the voltage less than 1 V?
- YES** : Go to step 10H13.
- NO** : Replace ABS sensor.

**10H13 : CHECK BATTERY SHORT OF ABS SENSOR.**

- 1) Turn ignition switch to ON.
- 2) Measure voltage between ABS sensor and chassis ground.

**Terminals**

- Front RH No. 1 (+) — Chassis ground (-):
- Front LH No. 1 (+) — Chassis ground (-):
- Rear RH No. 1 (+) — Chassis ground (-):
- Rear LH No. 1 (+) — Chassis ground (-):

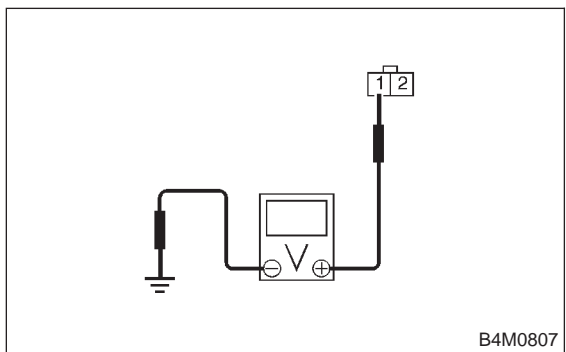

- CHECK** : Is the voltage less than 1 V?
- YES** : Go to step 10H14.
- NO** : Replace ABS sensor.

**10H14 : CHECK TROUBLE CODE.**

- CHECK** : Is the trouble code 21 and/or 23?
- YES** : Go to step 10H15.
- NO** : Go to step 10H16.

**10H15 : CHECK HARNESS/CONNECTOR BETWEEN ABSCM&H/U AND ABS SENSOR.**

- 1) Turn ignition switch to OFF.
- 2) Connect connector to ABS sensor.
- 3) Measure resistance between ABSCM&H/U connector terminals.

**Connector & terminal**

- Trouble code 21 / (F49) No. 11 — No. 12:
- Trouble code 23 / (F49) No. 9 — No. 10:

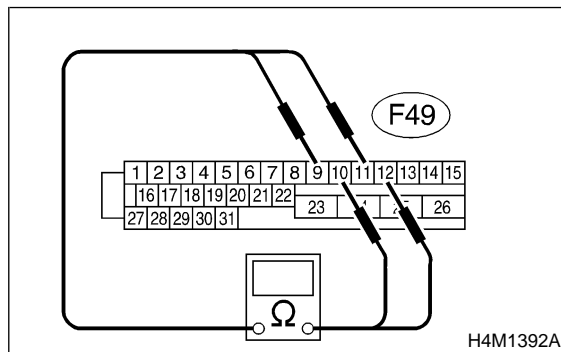

- CHECK** : Is the resistance between 1.0 and 1.5 kΩ?
- YES** : Go to step 10H17.
- NO** : Repair harness/connector between ABSCM&H/U and ABS sensor.

**10H16 : CHECK HARNESS/CONNECTOR BETWEEN ABSCM&H/U AND ABS SENSOR.**

- 1) Turn ignition switch to OFF.
- 2) Connect connector to ABS sensor.
- 3) Measure resistance between ABSCM&H/U connector terminals.

**Connector & terminal**

**Trouble code 25 / (F49) No. 13 — No. 15:**

**Trouble code 27 / (F49) No. 7 — No. 8:**

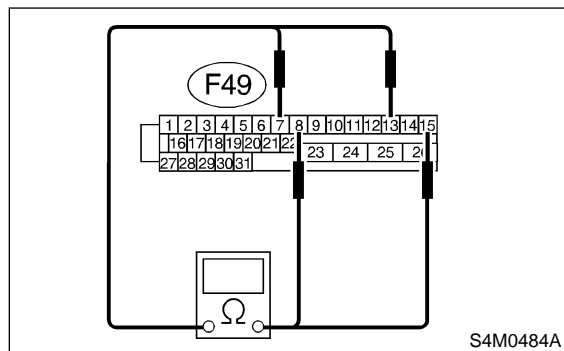

- CHECK** : **Is the resistance between 0.8 and 1.2 kΩ?**
- YES** : Go to step 10H17.
- NO** : Repair harness/connector between ABSCM&H/U and ABS sensor.

**10H17 : CHECK BATTERY SHORT OF HARNESS.**

Measure voltage between ABSCM&H/U connector and chassis ground.

**Connector & terminal**

**Trouble code 21 / (F49) No. 11 (+) —**

**Chassis ground (-):**

**Trouble code 23 / (F49) No. 9 (+) — Chassis ground (-):**

**Trouble code 25 / (F49) No. 13 (+) —**

**Chassis ground (-):**

**Trouble code 27 / (F49) No. 7 (+) — Chassis ground (-):**

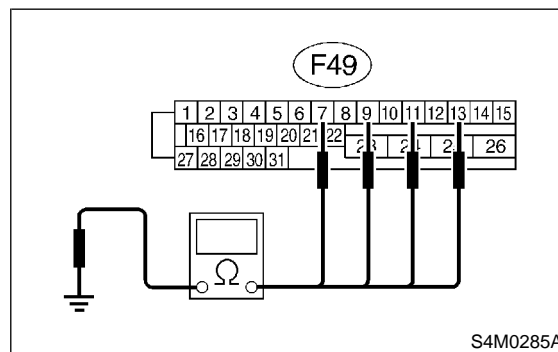

- CHECK** : **Is the voltage less than 1 V?**
- YES** : Go to step 10H18.
- NO** : Repair harness between ABSCM&H/U and ABS sensor.

**10H18 : CHECK BATTERY SHORT OF HARNESS.**

- 1) Turn ignition switch to ON.
- 2) Measure voltage between ABSCM&H/U connector and chassis ground.

**Connector & terminal**

- Trouble code 21 / (F49) No. 11 (+) — Chassis ground (-):**
- Trouble code 23 / (F49) No. 9 (+) — Chassis ground (-):**
- Trouble code 25 / (F49) No. 13 (+) — Chassis ground (-):**
- Trouble code 27 / (F49) No. 7 (+) — Chassis ground (-):**

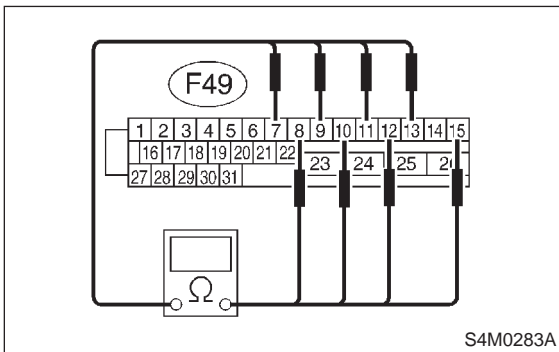

- CHECK** : *Is the voltage less than 1 V?*
- YES** : Go to step **10H19**.
- NO** : Repair harness between ABSCM&H/U and ABS sensor.

**10H19 : CHECK INSTALLATION OF ABS SENSOR.**

**Tightening torque:**

**32±10 N·m (3.3±1.0 kg·m, 24±7 ft·lb)**

- CHECK** : *Are the ABS sensor installation bolts tightened securely?*
- YES** : Go to step **10H20**.
- NO** : Tighten ABS sensor installation bolts securely.

**10H20 : CHECK TROUBLE CODE.**

- CHECK** : *Is the trouble code 21 and/or 23?*
- YES** : Go to step **10H22**.
- NO** : Go to step **10H21**.

**10H21 : CHECK INSTALLATION OF REAR TONE WHEEL.**

**Tightening torque:**

**13±3 N·m (1.3±0.3 kg·m, 9±2.2 ft·lb)**

- CHECK** : *Are the rear tone wheel installation bolts tightened securely?*
- YES** : Go to step **10H22**.
- NO** : Tighten rear tone wheel installation bolts securely.

**10H22 : CHECK ABS SENSOR GAP.**

Measure tone wheel-to-pole piece gap over entire perimeter of the wheel. <Ref. to 4-4 [W13C0].>

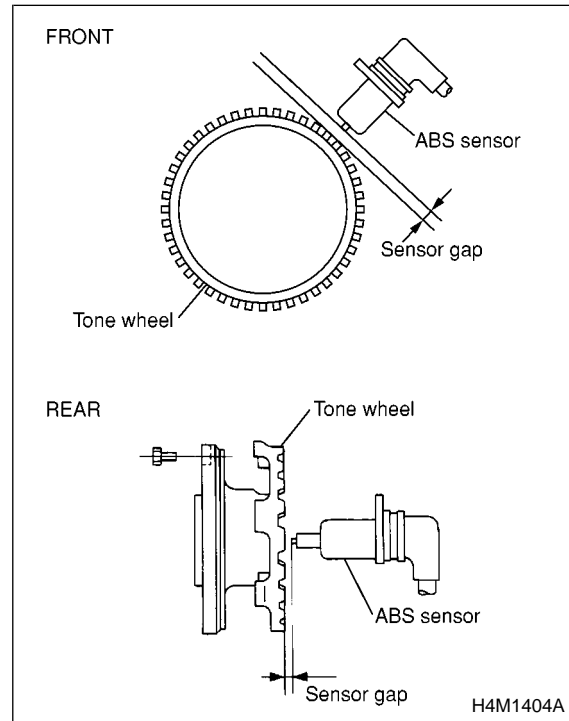

	Front wheel	Rear wheel
Specifications	0.3 — 0.8 mm (0.012 — 0.031 in)	0.7 — 1.2 mm (0.028 — 0.047 in)

- CHECK** : *Is the gap within the specifications?*
- YES** : Go to step **10H23**.
- NO** : Adjust the gap.

**NOTE:**

Adjust the gap using spacers (Part No. 26755AA000). If spacers cannot correct the gap, replace worn sensor or worn tone wheel.



**10H23 : CHECK HUB RUNOUT.**

Measure hub runout.

**CHECK** : *Is the runout less than 0.05 mm (0.0020 in)?*

**YES** : Go to step 10H24.

**NO** : Repair hub.

**10H24 : CHECK GROUND SHORT OF ABS SENSOR.**

- 1) Turn ignition switch to OFF.
- 2) Measure resistance between ABS sensor and chassis ground.

**Terminals**

**Front RH No. 1 — Chassis ground:**

**Front LH No. 1 — Chassis ground:**

**Rear RH No. 1 — Chassis ground:**

**Rear LH No. 1 — Chassis ground:**

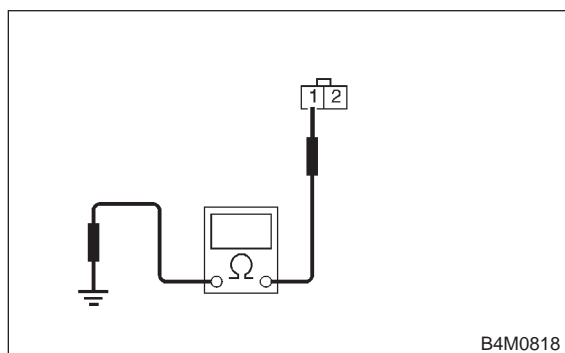

**CHECK** : *Is the resistance more than 1 MΩ?*

**YES** : Go to step 10H25.

**NO** : Replace ABS sensor and ABSCM&H/U. <Ref. to 4-4 [W14A0].>

**10H25 : CHECK GROUND SHORT OF HARNESS.**

- 1) Turn ignition switch to OFF.
- 2) Connect connector to ABS sensor.
- 3) Measure resistance between ABSCM&H/U connector terminal and chassis ground.

**Connector & terminal**

**Trouble code 21 / (F49) No. 11 — Chassis ground:**

**Trouble code 23 / (F49) No. 9 — Chassis ground:**

**Trouble code 25 / (F49) No. 13 — Chassis ground:**

**Trouble code 27 / (F49) No. 7 — Chassis ground:**

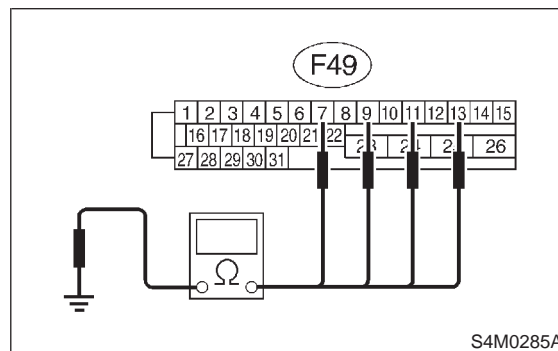

**CHECK** : *Is the resistance more than 1 MΩ?*

**YES** : Go to step 10H26.

**NO** : Repair harness between ABSCM&H/U and ABS sensor. And replace ABSCM&H/U. <Ref. to 4-4 [W14A0].>

**10H26 : CHECK POOR CONTACT IN CONNECTORS.**

**CHECK** : *Is there poor contact in connectors between ABSCM&H/U and ABS sensor? <Ref. to FOREWORD [W3C1].>*

**YES** : Repair connector.

**NO** : Go to step 10H27.

**10H27 : CHECK ABSCM&H/U.**

- 1) Connect all connectors.
- 2) Erase the memory.
- 3) Perform inspection mode.
- 4) Read out the trouble code.

**CHECK** : *Is the same trouble code as in the current diagnosis still being output?*

**YES** : Replace ABSCM&H/U. <Ref. to 4-4 [W14A0].>

**NO** : Go to step **10H28**.

**10H28 : CHECK ANY OTHER TROUBLE CODES APPEARANCE.**

**CHECK** : *Are other trouble codes being output?*

**YES** : Proceed with the diagnosis corresponding to the trouble code.

**NO** : A temporary poor contact.

**NOTE:**

Check harness and connectors between ABSCM&H/U and ABS sensor.

**MEMO:**

**I: TROUBLE CODE 22 FRONT RIGHT ABS SENSOR ABNORMAL SIGNAL**

**J: TROUBLE CODE 24 FRONT LEFT ABS SENSOR ABNORMAL SIGNAL**

**K: TROUBLE CODE 26 REAR RIGHT ABS SENSOR ABNORMAL SIGNAL**

**L: TROUBLE CODE 28 REAR LEFT ABS SENSOR ABNORMAL SIGNAL**

**— ABNORMAL ABS SENSOR (ABS SENSOR ABNORMAL SIGNAL) —**

**DIAGNOSIS:**

- Faulty ABS sensor signal (noise, irregular signal, etc.)
- Faulty harness/connector

**TROUBLE SYMPTOM:**

- ABS does not operate.

**WIRING DIAGRAM:**

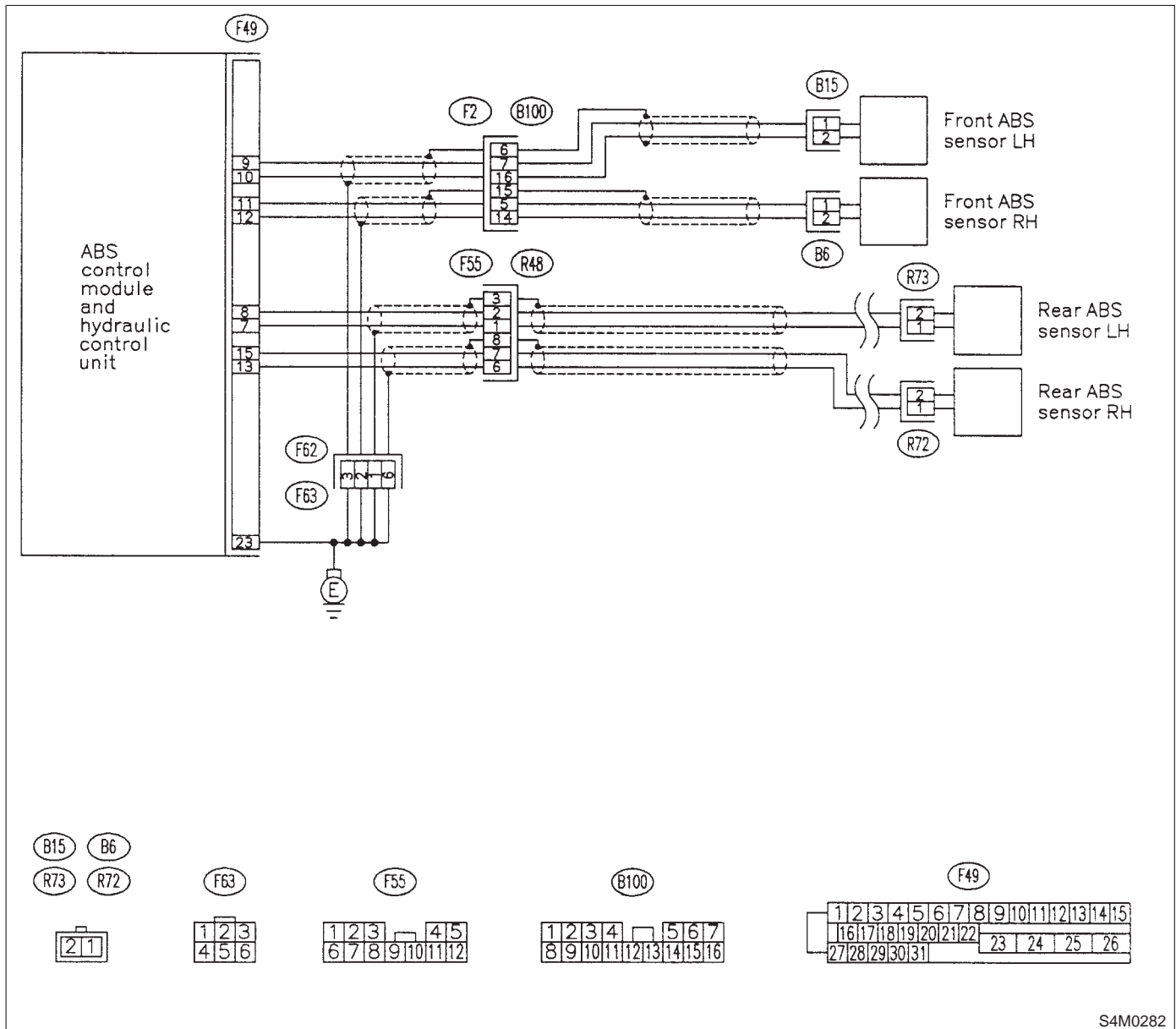

**10L1 : CHECK OUTPUT OF ABS SENSOR USING SELECT MONITOR.**

- 1) Select "Current data display & Save" on the select monitor.
- 2) Read the ABS sensor output corresponding to the faulty system in the select monitor data display mode.

**CHECK** : *Does the speed indicated on the display change in response to the speedometer reading during acceleration/deceleration when the steering wheel is in the straight-ahead position?*

**YES** : Go to step 10L2.

**NO** : Go to step 10L8.

**10L2 : CHECK POOR CONTACT IN CONNECTORS.**

Turn ignition switch to OFF.

**CHECK** : *Is there poor contact in connectors between ABSCM&H/U and ABS sensor? <Ref. to FOREWORD [W3C1].>*

**YES** : Repair connector.

**NO** : Go to step 10L3.

**10L3 : CHECK SOURCES OF SIGNAL NOISE.**

**CHECK** : *Is the car telephone or the wireless transmitter properly installed?*

**YES** : Go to step 10L4.

**NO** : Properly install the car telephone or the wireless transmitter.

**10L4 : CHECK SOURCES OF SIGNAL NOISE.**

**CHECK** : *Are noise sources (such as an antenna) installed near the sensor harness?*

**YES** : Install the noise sources apart from the sensor harness.

**NO** : Go to step 10L5.

**10L5 : CHECK SHIELD CIRCUIT.**

- 1) Turn ignition switch to OFF.
- 2) Connect all connectors.
- 3) Measure resistance between shield connector and chassis ground.

**Connector & terminal**

**Trouble code 22 / (B100) No. 15 — Chassis ground:**

**Trouble code 24 / (B100) No. 6 — Chassis ground:**

**Trouble code 26 / (F55) No. 8 — Chassis ground:**

**Trouble code 28 / (F55) No. 3 — Chassis ground:**

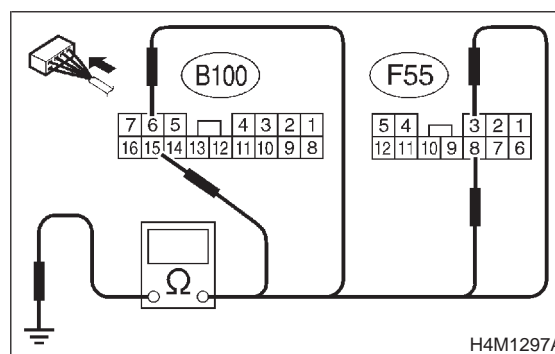

**CHECK** : *Is the resistance less than 0.5 Ω?*

**YES** : Go to step 10L6.

**NO** : Repair shield harness.

**10L6 : CHECK ABSCM&H/U.**

- 1) Connect all connectors.
- 2) Erase the memory.
- 3) Perform inspection mode.
- 4) Read out the trouble code.

**CHECK** : *Is the same trouble code as in the current diagnosis still being output?*

**YES** : Replace ABSCM&H/U. <Ref. to 4-4 [W14A0].>

**NO** : Go to step 10L7.

**10L7 : CHECK ANY OTHER TROUBLE CODES APPEARANCE.**

**CHECK** : *Are other trouble codes being output?*

**YES** : Proceed with the diagnosis corresponding to the trouble code.

**NO** : A temporary noise interference.

**10L8 : CHECK INSTALLATION OF ABS SENSOR.**

**Tightening torque:**

**$32 \pm 10$  N·m ( $3.3 \pm 1.0$  kg·m,  $24 \pm 7$  ft·lb)**

- CHECK** : Are the ABS sensor installation bolts tightened securely?
- YES** : Go to step 10L9.
- NO** : Tighten ABS sensor installation bolts securely.

**10L9 : CHECK TROUBLE CODE.**

- CHECK** : Is the trouble code 22 and/or 24?
- YES** : Go to step 10L11.
- NO** : Go to step 10L10.

**10L10 : CHECK INSTALLATION OF REAR TONE WHEEL.**

**Tightening torque:**

**$13 \pm 3$  N·m ( $1.3 \pm 0.3$  kg·m,  $9 \pm 2.2$  ft·lb)**

- CHECK** : Are the rear tone wheel installation bolts tightened securely?
- YES** : Go to step 10L11.
- NO** : Tighten rear tone wheel installation bolts securely.

**10L11 : CHECK ABS SENSOR GAP.**

Measure tone wheel to pole piece gap over entire perimeter of the wheel. <Ref. to 4-4 [W13C0].>

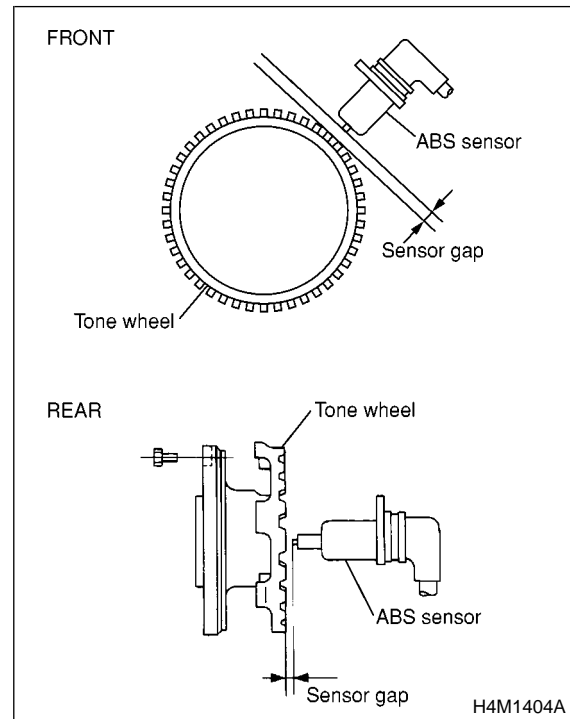

	Front wheel	Rear wheel
Specifications	0.3 — 0.8 mm (0.012 — 0.031 in)	0.7 — 1.2 mm (0.028 — 0.047 in)

- CHECK** : Is the gap within the specifications?
- YES** : Go to step 10L12.
- NO** : Adjust the gap.

**NOTE:**

Adjust the gap using spacer (Part No. 26755AA000). If spacers cannot correct the gap, replace worn sensor or worn tone wheel.

**10L12 : PREPARE OSCILLOSCOPE.**

- CHECK** : Is an oscilloscope available?
- YES** : Go to step 10L13.
- NO** : Go to step 10L14.

**10L13 : CHECK ABS SENSOR SIGNAL.**

- 1) Raise all four wheels of ground.
- 2) Turn ignition switch to OFF.
- 3) Connect the oscilloscope to the connector.
- 4) Turn ignition switch to ON.
- 5) Rotate wheels and measure voltage at specified frequency.

**NOTE:**

When this inspection is completed, the ABSCM&H/U sometimes stores the trouble code 29.

**Connector & terminal**

**Trouble code 22 / (B100) No. 5 (+) — No. 14 (-):**

**Trouble code 24 / (B100) No. 7 (+) — No. 16 (-):**

**Trouble code 26 / (F55) No. 6 (+) — No. 7 (-):**

**Trouble code 28 / (F55) No. 1 (+) — No. 2 (-):**

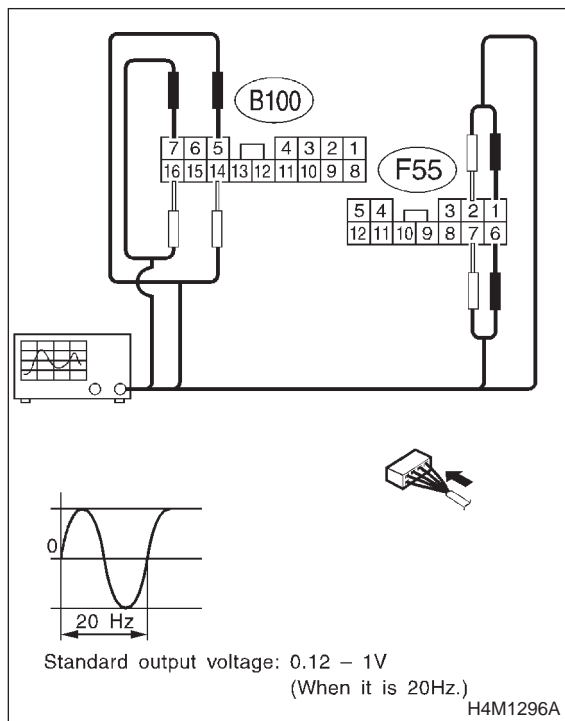

**CHECK** : *Is oscilloscope pattern smooth, as shown in figure?*

**YES** : Go to step 10L17.

**NO** : Go to step 10L14.

**10L14 : CHECK CONTAMINATION OF ABS SENSOR OR TONE WHEEL.**

Remove disc rotor or drum from hub in accordance with trouble code.

**CHECK** : *Is the ABS sensor pole piece or the tone wheel contaminated by dirt or other foreign matter?*

**YES** : Thoroughly remove dirt or other foreign matter.

**NO** : Go to step 10L15.

**10L15 : CHECK DAMAGE OF ABS SENSOR OR TONE WHEEL.**

**CHECK** : *Are there broken or damaged in the ABS sensor pole piece or the tone wheel?*

**YES** : Replace ABS sensor or tone wheel.

**NO** : Go to step 10L16.

**10L16 : CHECK HUB RUNOUT.**

Measure hub runout.

**CHECK** : *Is the runout less than 0.05 mm (0.0020 in)?*

**YES** : Go to step 10L17.

**NO** : Repair hub.

**10L17 : CHECK RESISTANCE OF FRONT ABS SENSOR.**

- 1) Turn ignition switch to OFF.
- 2) Disconnect connector from front ABS sensor.
- 3) Measure resistance between front ABS sensor connector terminals.

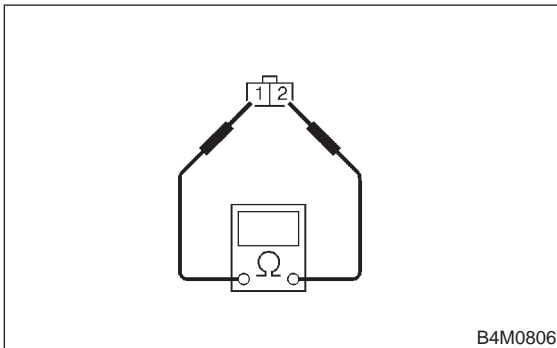
**Terminals****RH No. 1 — No. 2:****LH No. 1 — No. 2:**

- CHECK** : **Is the resistance between 1.0 and 1.5 k $\Omega$ ?**
- YES** : Go to step **10L18**.
- NO** : Replace front ABS sensor.

**10L18 : CHECK RESISTANCE OF REAR ABS SENSOR.**

- 1) Turn ignition switch to OFF.
- 2) Disconnect connector from rear ABS sensor.
- 3) Measure resistance between rear ABS sensor connector terminals.

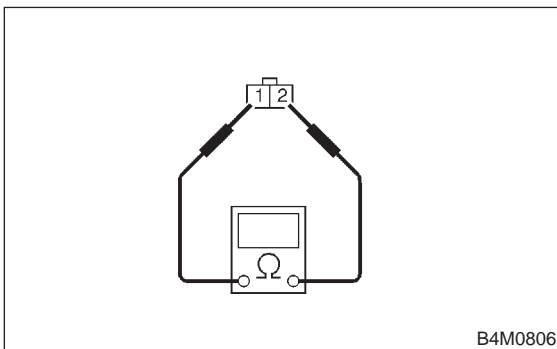
**Terminals****RH No. 1 — No. 2:****LH No. 1 — No. 2:**

- CHECK** : **Is the resistance between 0.8 and 1.2 k $\Omega$ ?**
- YES** : Go to step **10L19**.
- NO** : Replace rear ABS sensor.

**10L19 : CHECK GROUND SHORT OF ABS SENSOR.**

Measure resistance between ABS sensor and chassis ground.

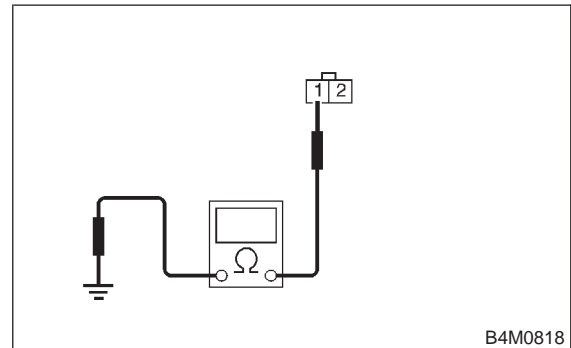
**Terminals****Front RH No. 1 — Chassis ground:****Front LH No. 1 — Chassis ground:****Rear RH No. 1 — Chassis ground:****Rear LH No. 1 — Chassis ground:**

- CHECK** : **Is the resistance more than 1 M $\Omega$ ?**
- YES** : Go to step **10L20**.
- NO** : Replace ABS sensor.

**10L20 : CHECK TROUBLE CODE.**

- CHECK** : **Is the trouble code 22 and/or 24?**
- YES** : Go to step **10L21**.
- NO** : Go to step **10L22**.



**10L21 : CHECK HARNESS/CONNECTOR BETWEEN ABSCM&H/U AND ABS SENSOR.**

- 1) Connect connector to ABS sensor.
- 2) Disconnect connector from ABSCM&H/U.
- 3) Measure resistance at ABSCM&H/U connector terminals.

**Connector & terminal**

**Trouble code 22 / (F49) No. 11 — No. 12:**

**Trouble code 24 / (F49) No. 9 — No. 10:**

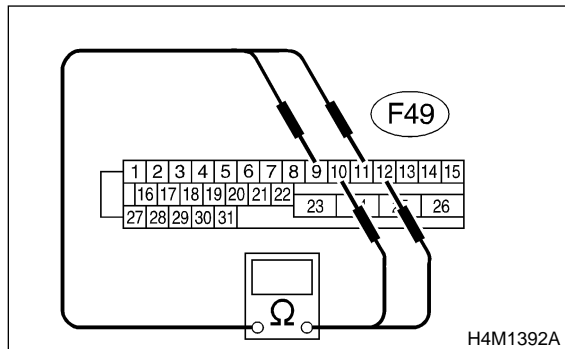

- CHECK** : **Is the resistance between 1.0 and 1.5 kΩ?**
- YES** : Go to step **10L23**.
- NO** : Repair harness/connector between ABSCM&H/U and ABS sensor.

**10L22 : CHECK HARNESS/CONNECTOR BETWEEN ABSCM&H/U AND ABS SENSOR.**

- 1) Connect connector to ABS sensor.
- 2) Disconnect connector from ABSCM&H/U.
- 3) Measure resistance at ABSCM&H/U connector terminals.

**Connector & terminal**

**Trouble code 26 / (F49) No. 13 — No. 15:**

**Trouble code 28 / (F49) No. 7 — No. 8:**

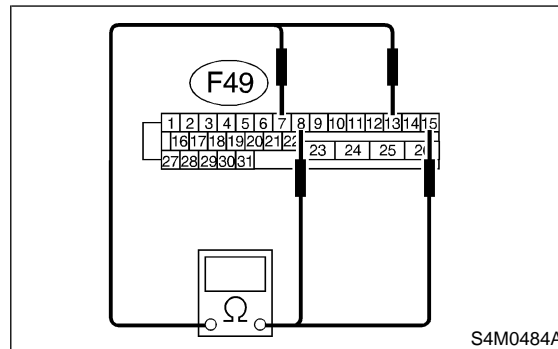

- CHECK** : **Is the resistance between 0.8 and 1.2 kΩ?**
- YES** : Go to step **10L23**.
- NO** : Repair harness/connector between ABSCM&H/U and ABS sensor.

**10L23 : CHECK GROUND SHORT OF HARNESS.**

Measure resistance between ABSCM&H/U connector and chassis ground.

**Connector & terminal**

**Trouble code 22 / (F49) No. 11 — Chassis ground:**

**Trouble code 24 / (F49) No. 9 — Chassis ground:**

**Trouble code 26 / (F49) No. 13 — Chassis ground:**

**Trouble code 28 / (F49) No. 7 — Chassis ground:**

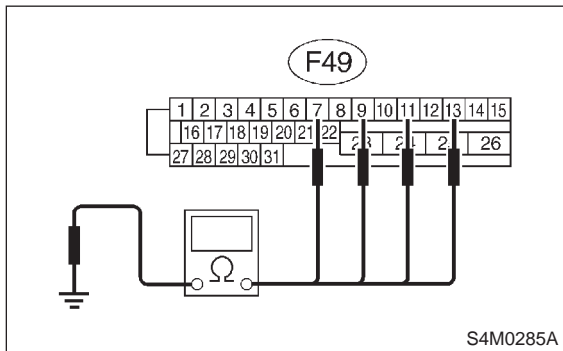

- CHECK** : *Is the resistance more than 1 MΩ?*
- YES** : Go to step 10L24.
- NO** : Repair harness/connector between ABSCM&H/U and ABS sensor.

**10L24 : CHECK GROUND CIRCUIT OF ABSCM&H/U.**

Measure resistance between ABSCM&H/U and chassis ground.

**Connector & terminal**

**(F49) No. 23 — Chassis ground:**

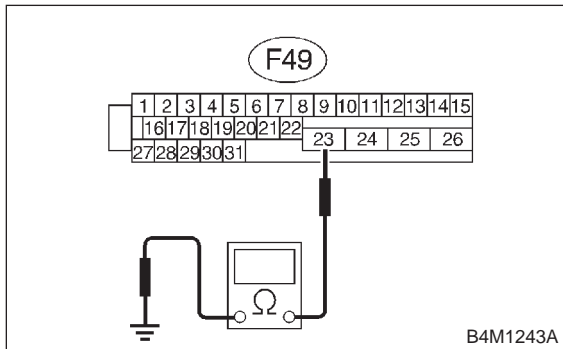

- CHECK** : *Is the resistance less than 0.5 Ω?*
- YES** : Go to step 10L25.
- NO** : Repair ABSCM&H/U ground harness.

**10L25 : CHECK POOR CONTACT IN CONNECTORS.**

- CHECK** : *Is there poor contact in connectors between ABSCM&H/U and ABS sensor? <Ref. to FOREWORD [W3C1].>*
- YES** : Repair connector.
- NO** : Go to step 10L26.

**10L26 : CHECK SOURCES OF SIGNAL NOISE.**

- CHECK** : *Is the car telephone or the wireless transmitter properly installed?*
- YES** : Go to step 10L27.
- NO** : Properly install the car telephone or the wireless transmitter.

**10L27 : CHECK SOURCES OF SIGNAL NOISE.**

- CHECK** : *Are noise sources (such as an antenna) installed near the sensor harness?*
- YES** : Install the noise sources apart from the sensor harness.
- NO** : Go to step 10L28.

**10L28 : CHECK SHIELD CIRCUIT.**

- 1) Connect all connectors.
- 2) Measure resistance between shield connector and chassis ground.

**Connector & terminal**

**Trouble code 22 / (B100) No. 15 — Chassis ground:**

**Trouble code 24 / (B100) No. 6 — Chassis ground:**

**Trouble code 26 / (F55) No. 8 — Chassis ground:**

**Trouble code 28 / (F55) No. 3 — Chassis ground:**

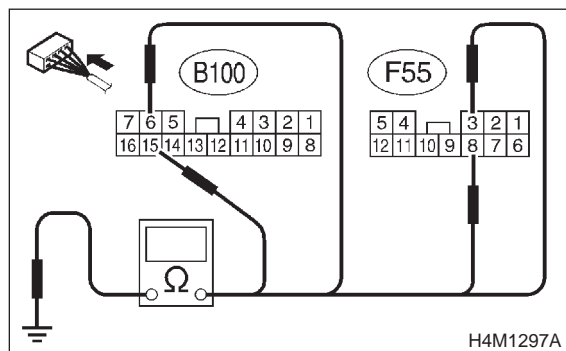

- CHECK** : **Is the resistance less than 0.5 Ω?**
- YES** : Go to step **10L29**.
- NO** : Repair shield harness.

**10L29 : CHECK ABSCM&H/U.**

- 1) Connect all connectors.
- 2) Erase the memory.
- 3) Perform inspection mode.
- 4) Read out the trouble code.

- CHECK** : **Is the same trouble code as in the current diagnosis still being output?**
- YES** : Replace ABSCM&H/U. <Ref. to 4-4 [W14A0].>
- NO** : Go to step **10L30**.

**10L30 : CHECK ANY OTHER TROUBLE CODES APPEARANCE.**

- CHECK** : **Are other trouble codes being output?**
- YES** : Proceed with the diagnosis corresponding to the trouble code.
- NO** : A temporary noise interference.

**M: TROUBLE CODE 29 ABNORMAL ABS SENSOR SIGNAL ON ANY ONE OF FOUR SENSOR**

**— ABNORMAL ABS SENSOR SIGNAL ON ANY ONE OF FOUR —**

**DIAGNOSIS:**

- Faulty ABS sensor signal (noise, irregular signal, etc.)
- Faulty tone wheel
- Wheels turning freely for a long time

**TROUBLE SYMPTOM:**

- ABS does not operate.

**WIRING DIAGRAM:**

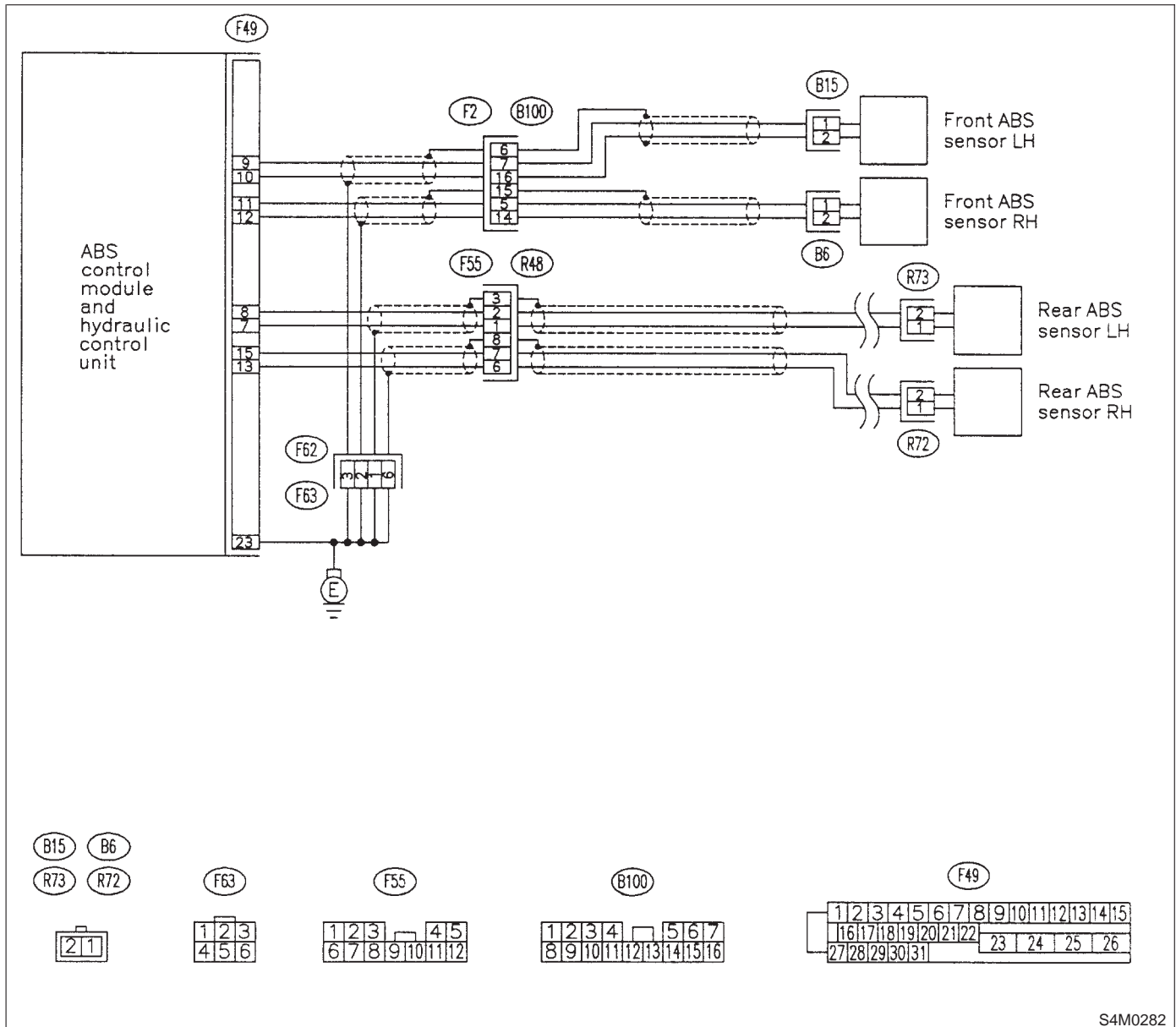

S4M0282

**10M1 : CHECK IF THE WHEELS HAVE TURNED FREELY FOR A LONG TIME.**

**CHECK** : Check if the wheels have been turned freely for more than one minute, such as when the vehicle is jacked-up, under full-lock cornering or when tire is not in contact with road surface.

**YES** : The ABS is normal. Erase the trouble code.

**NOTE:**

When the wheels turn freely for a long time, such as when the vehicle is towed or jacked-up, or when steering wheel is continuously turned all the way, this trouble code may sometimes occur.

**NO** : Go to step 10M2.

**10M2 : CHECK TIRE SPECIFICATIONS.**

Turn ignition switch to OFF.

**CHECK** : Are the tire specifications correct?

**YES** : Go to step 10M3.

**NO** : Replace tire.

**10M3 : CHECK WEAR OF TIRE.**

**CHECK** : Is the tire worn excessively?

**YES** : Replace tire.

**NO** : Go to step 10M4.

**10M4 : CHECK TIRE PRESSURE.**

**CHECK** : Is the tire pressure correct?

**YES** : Go to step 10M5.

**NO** : Adjust tire pressure.

**10M5 : CHECK INSTALLATION OF ABS SENSOR.**

**Tightening torque:**

**32±10 N-m (3.3±1.0 kg-m, 24±7 ft-lb)**

**CHECK** : Are the ABS sensor installation bolts tightened securely?

**YES** : Go to step 10M6.

**NO** : Tighten ABS sensor installation bolts securely.

**10M6 : CHECK INSTALLATION OF REAR TONE WHEEL.**

**Tightening torque:**

**13±3 N-m (1.3±0.3 kg-m, 9±2.2 ft-lb)**

**CHECK** : Are the rear tone wheel installation bolts tightened securely?

**YES** : Go to step 10M7.

**NO** : Tighten rear tone wheel installation bolts securely.

**10M7 : CHECK ABS SENSOR GAP.**

Measure tone wheel to pole piece gap over entire perimeter of the wheel. <Ref. to 4-4 [W13C0].>

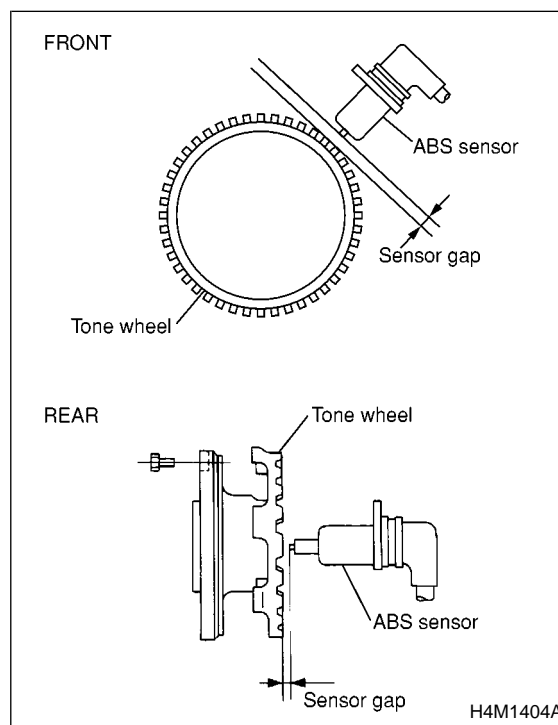

Specifications	Front wheel	Rear wheel
	0.3 — 0.8 mm (0.012 — 0.031 in)	0.7 — 1.2 mm (0.028 — 0.047 in)

**CHECK** : Is the gap within the specifications?

**YES** : Go to step 10M8.

**NO** : Adjust the gap.

**NOTE:**

Adjust the gap using spacer (Part No. 26755AA000). If spacers cannot correct the gap, replace worn sensor or worn tone wheel.

**10M8 : PREPARE OSCILLOSCOPE.****CHECK** : *Is an oscilloscope available?***YES** : Go to step **10M9**.**NO** : Go to step **10M10**.**10M9 : CHECK ABS SENSOR SIGNAL.**

- 1) Raise all four wheels of ground.
- 2) Turn ignition switch to OFF.
- 3) Connect the oscilloscope to the connector.
- 4) Turn ignition switch to ON.
- 5) Rotate wheels and measure voltage at specified frequency.

**NOTE:**

When this inspection is completed, the ABSCM&H/U sometimes stores the trouble code 29.

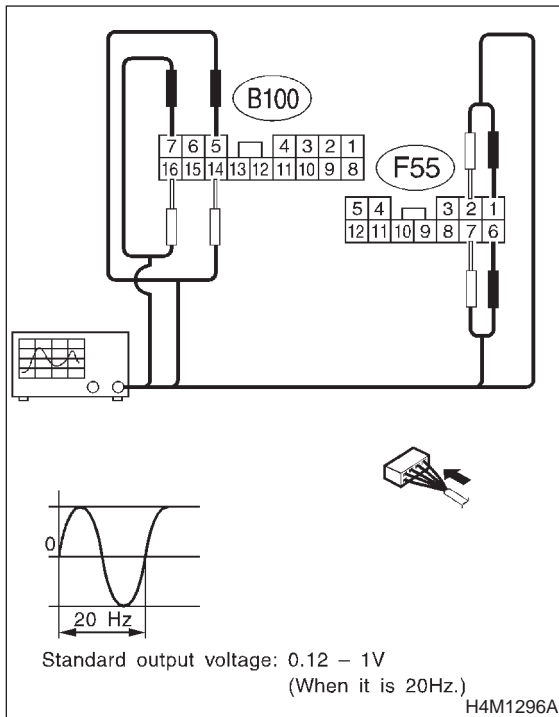
**Connector & terminal****(B100) No. 5 (+) — No. 14 (-) (Front RH):****(B100) No. 7 (+) — No. 16 (-) (Front LH):****(F55) No. 6 (+) — No. 7 (-) (Rear RH):****(F55) No. 1 (+) — No. 2 (-) (Rear LH):****CHECK** : *Is oscilloscope pattern smooth, as shown in figure?***YES** : Go to step **10M13**.**NO** : Go to step **10M10**.**10M10 : CHECK CONTAMINATION OF ABS SENSOR OR TONE WHEEL.**

Remove disc rotor from hub.

**CHECK** : *Is the ABS sensor pole piece or the tone wheel contaminated by dirt or other foreign matter?***YES** : Thoroughly remove dirt or other foreign matter.**NO** : Go to step **10M11**.**10M11 : CHECK DAMAGE OF ABS SENSOR OR TONE WHEEL.****CHECK** : *Are there broken or damaged teeth in the ABS sensor pole piece or the tone wheel?***YES** : Replace ABS sensor or tone wheel.**NO** : Go to step **10M12**.**10M12 : CHECK HUB RUNOUT.**

Measure hub runout.

**CHECK** : *Is the runout less than 0.05 mm (0.0020 in)?***YES** : Go to step **10M13**.**NO** : Repair hub.**10M13 : CHECK ABSCM&H/U.**

- 1) Turn ignition switch to OFF.
- 2) Connect all connectors.
- 3) Erase the memory.
- 4) Perform inspection mode.
- 5) Read out the trouble code.

**CHECK** : *Is the same trouble code as in the current diagnosis still being output?***YES** : Replace ABSCM&H/U. <Ref. to 4-4 [W14A0].>**NO** : Go to step **10M14**.**10M14 : CHECK ANY OTHER TROUBLE CODES APPEARANCE.****CHECK** : *Are other trouble codes being output?***YES** : Proceed with the diagnosis corresponding to the trouble code.**NO** : A temporary poor contact.

MEMO:

**N: TROUBLE CODE 31 FRONT RIGHT INLET VALVE MALFUNCTION**

**O: TROUBLE CODE 33 FRONT LEFT INLET VALVE MALFUNCTION**

**P: TROUBLE CODE 35 REAR RIGHT INLET VALVE MALFUNCTION**

**Q: TROUBLE CODE 37 REAR LEFT INLET VALVE MALFUNCTION**

**— INLET SOLENOID VALVE MALFUNCTION —**

**DIAGNOSIS:**

- Faulty harness/connector
- Faulty inlet solenoid valve

**TROUBLE SYMPTOM:**

- ABS does not operate.

**WIRING DIAGRAM:**

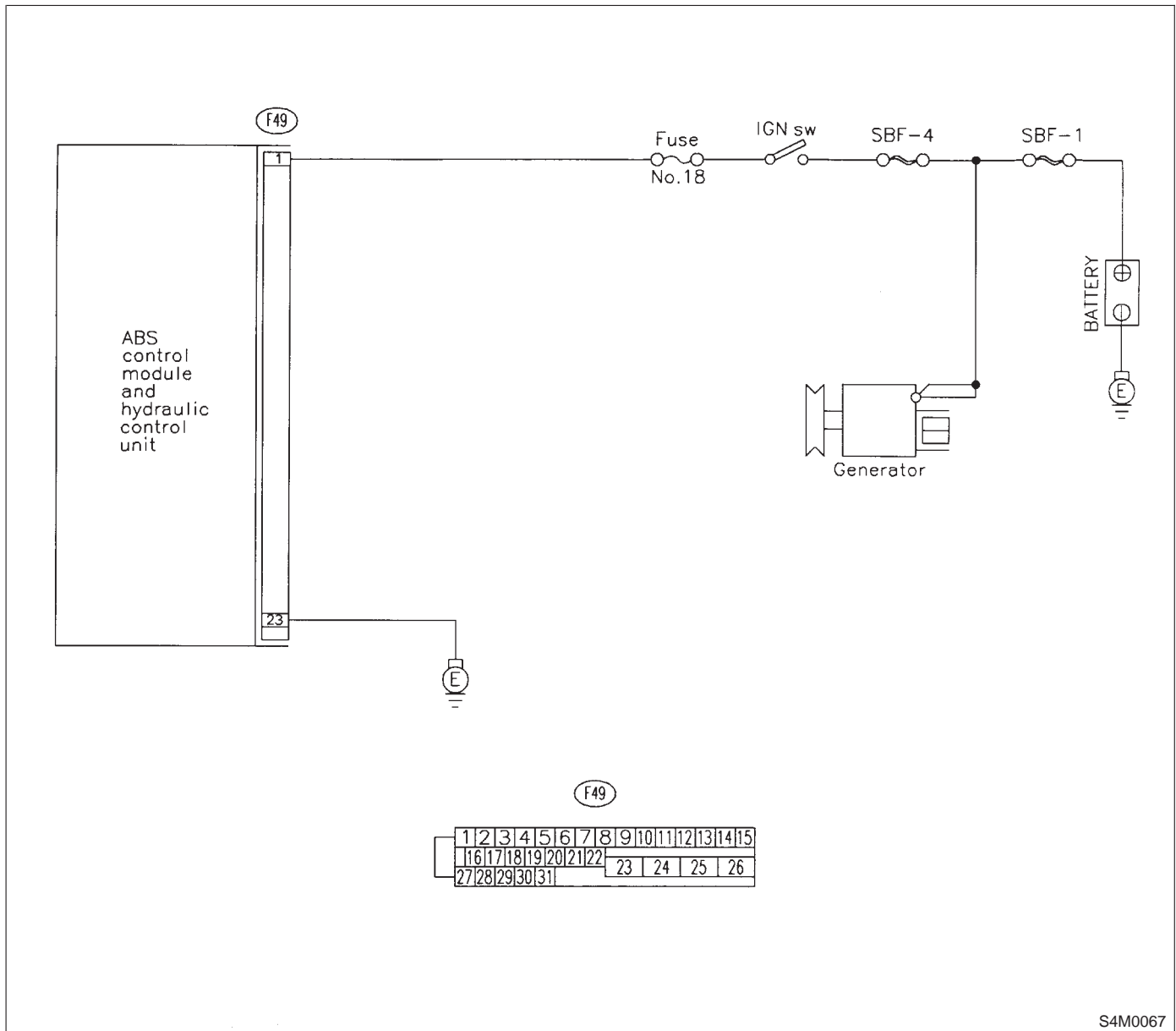

S4M0067



**10Q1 : CHECK INPUT VOLTAGE OF ABSCM&H/U.**

- 1) Turn ignition switch to OFF.
- 2) Disconnect connector from ABSCM&H/U.
- 3) Run the engine at idle.
- 4) Measure voltage between ABSCM&H/U connector and chassis ground.

**Connector & terminal**  
**(F49) No. 1 (+) — Chassis ground (-):**

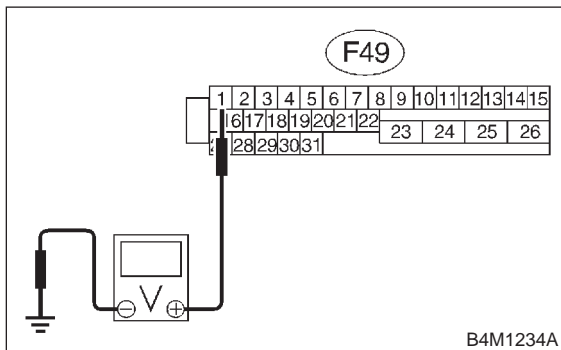

- CHECK** : *Is the voltage between 10 and 15 V?*
- YES** : Go to step 10Q2.
- NO** : Repair harness connector between battery, ignition switch and ABSCM&H/U.

**10Q2 : CHECK GROUND CIRCUIT OF ABSCM&H/U.**

- 1) Turn ignition switch to OFF.
- 2) Measure resistance between ABSCM&H/U connector and chassis ground.

**Connector & terminal**  
**(F49) No. 23 — Chassis ground:**

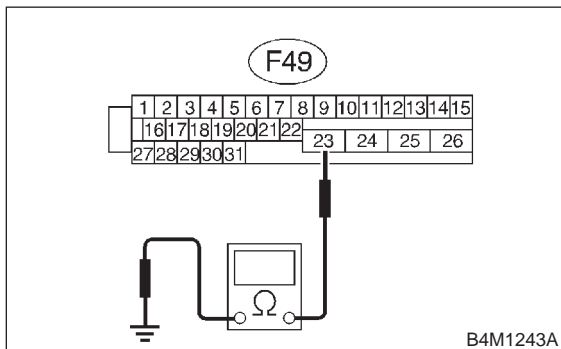

- CHECK** : *Is the resistance less than 0.5 Ω?*
- YES** : Go to step 10Q3.
- NO** : Repair ABSCM&H/U ground harness.

**10Q3 : CHECK POOR CONTACT IN CONNECTORS.**

- CHECK** : *Is there poor contact in connectors between generator, battery and ABSCM&H/U? <Ref. to FOREWORD [W3C1].>*
- YES** : Repair connector.
- NO** : Go to step 10Q4.

**10Q4 : CHECK ABSCM&H/U.**

- 1) Connect all connectors.
  - 2) Erase the memory.
  - 3) Perform inspection mode.
  - 4) Read out the trouble code.
- CHECK** : *Is the same trouble code as in the current diagnosis still being output?*
- YES** : Replace ABSCM&H/U. <Ref. to 4-4 [W14A0].>
- NO** : Go to step 10Q5.

**10Q5 : CHECK ANY OTHER TROUBLE CODES APPEARANCE.**

- CHECK** : *Are other trouble codes being output?*
- YES** : Proceed with the diagnosis corresponding to the trouble code.
- NO** : A temporary poor contact.

**R: TROUBLE CODE 32 FRONT RIGHT OUTLET VALVE MALFUNCTION**

**S: TROUBLE CODE 34 FRONT LEFT OUTLET VALVE MALFUNCTION**

**T: TROUBLE CODE 36 REAR RIGHT OUTLET VALVE MALFUNCTION**

**U: TROUBLE CODE 38 REAR LEFT OUTLET VALVE MALFUNCTION**

**— OUTLET SOLENOID VALVE MALFUNCTION —**

**DIAGNOSIS:**

- Faulty harness/connector
- Faulty outlet solenoid valve

**TROUBLE SYMPTOM:**

- ABS does not operate.

**WIRING DIAGRAM:**

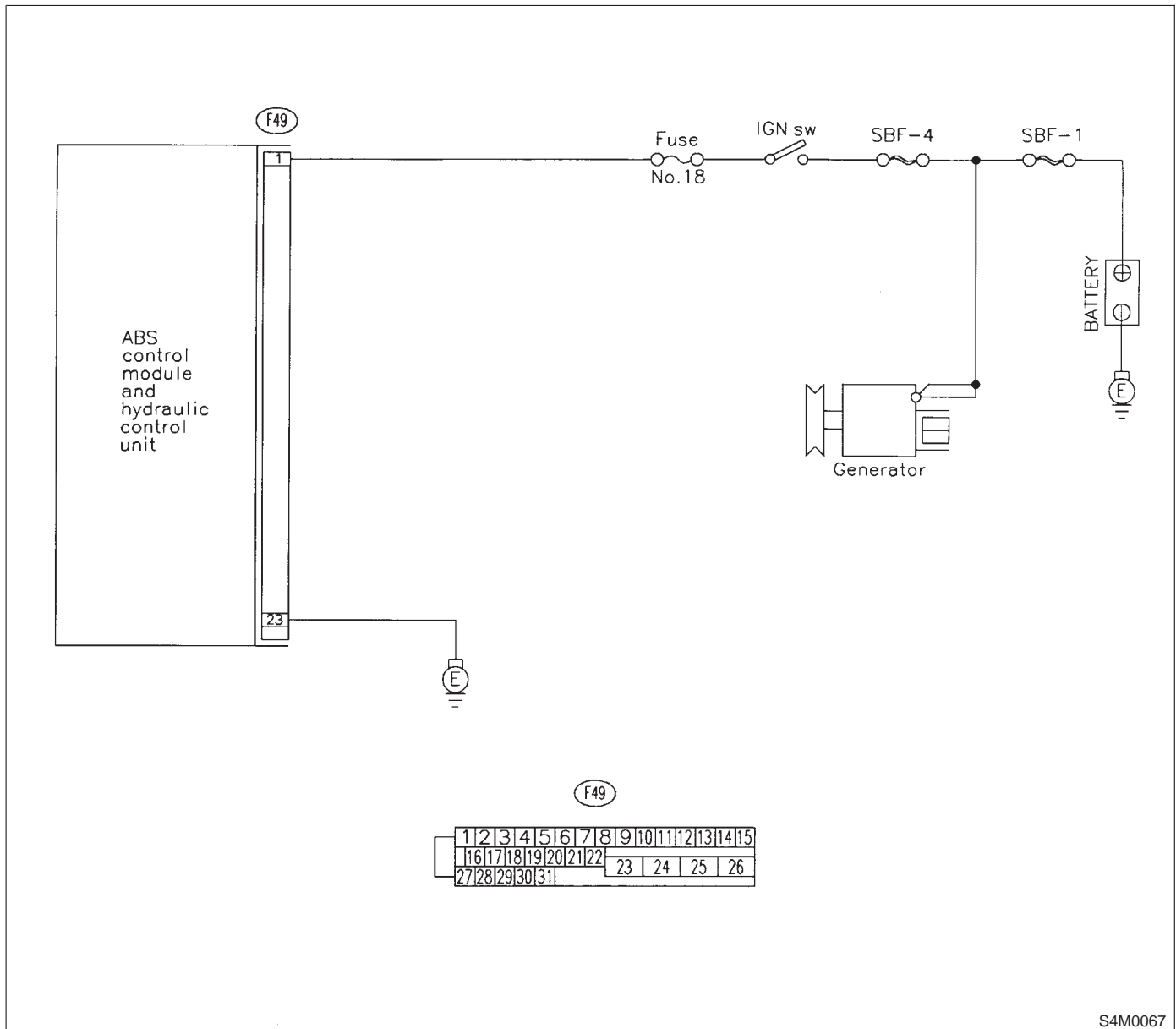

S4M0067

**10U1 : CHECK INPUT VOLTAGE OF ABSCM&H/U.**

- 1) Turn ignition switch to OFF.
- 2) Disconnect connector from ABSCM&H/U.
- 3) Run the engine at idle.
- 4) Measure voltage between ABSCM&H/U connector and chassis ground.

**Connector & terminal**

**(F49) No. 1 (+) — Chassis ground (-):**

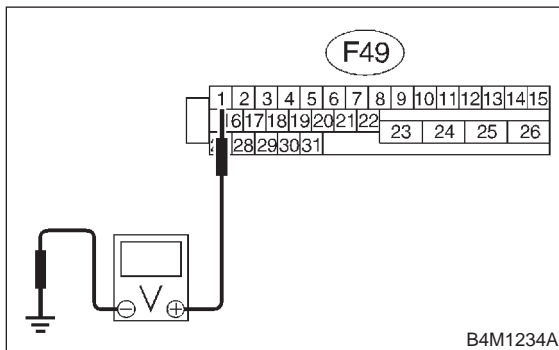

- CHECK** : *Is the voltage between 10 and 15 V?*
- YES** : Go to step 10U2.
- NO** : Repair harness connector between battery, ignition switch and ABSCM&H/U.

**10U2 : CHECK GROUND CIRCUIT OF ABSCM&H/U.**

- 1) Turn ignition switch to OFF.
- 2) Measure resistance between ABSCM&H/U connector and chassis ground.

**Connector & terminal**

**(F49) No. 23 — Chassis ground:**

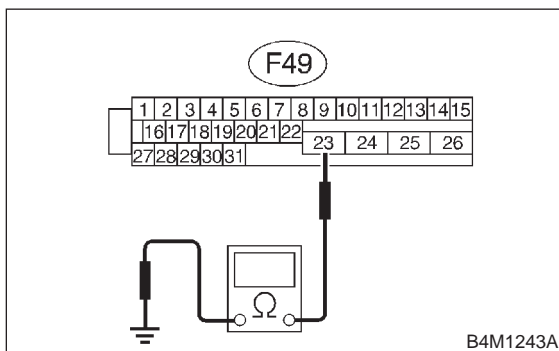

- CHECK** : *Is the resistance less than 0.5 Ω?*
- YES** : Go to step 10U3.
- NO** : Repair ABSCM&H/U ground harness.

**10U3 : CHECK POOR CONTACT IN CONNECTORS.**

- CHECK** : *Is there poor contact in connectors between generator, battery and ABSCM&H/U? <Ref. to FOREWORD [W3C1].>*
- YES** : Repair connector.
- NO** : Go to step 10U4.

**10U4 : CHECK ABSCM&H/U.**

- 1) Connect all connectors.
  - 2) Erase the memory.
  - 3) Perform inspection mode.
  - 4) Read out the trouble code.
- CHECK** : *Is the same trouble code as in the current diagnosis still being output?*
- YES** : Replace ABSCM&H/U. <Ref. to 4-4 [W14A0].>
- NO** : Go to step 10U5.

**10U5 : CHECK ANY OTHER TROUBLE CODES APPEARANCE.**

- CHECK** : *Are other trouble codes being output?*
- YES** : Proceed with the diagnosis corresponding to the trouble code.
- NO** : A temporary poor contact.

**V: TROUBLE CODE 41 ABS CONTROL MODULE MALFUNCTION  
— ABS CONTROL MODULE AND HYDRAULIC CONTROL UNIT  
MALFUNCTION —**

**DIAGNOSIS:**

- Faulty ABSCM&H/U

**TROUBLE SYMPTOM:**

- ABS does not operate.

**WIRING DIAGRAM:**

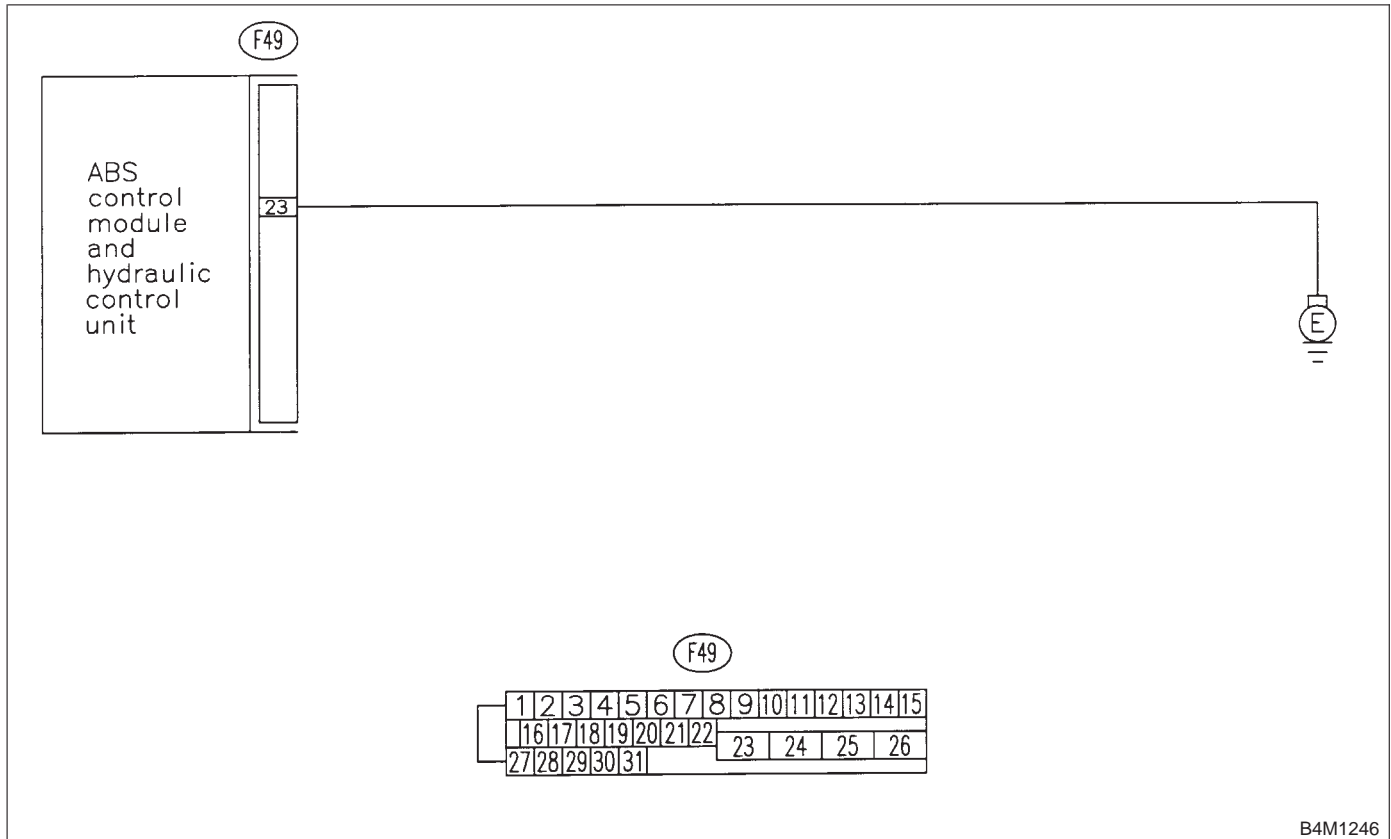

B4M1246

**10V1 : CHECK GROUND CIRCUIT OF ABSCM&H/U.**

- 1) Turn ignition switch to OFF.
- 2) Disconnect connector from ABSCM&H/U.
- 3) Measure resistance between ABSCM&H/U and chassis ground.

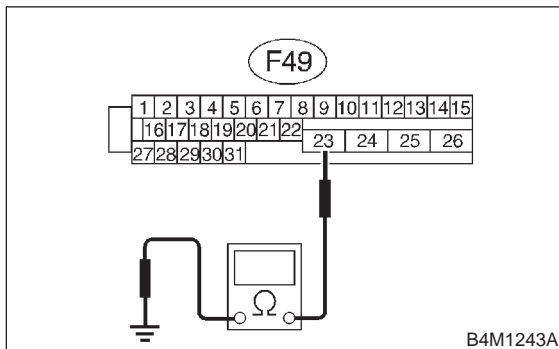
**Connector & terminal****(F49) No. 23 — Chassis ground:**

- CHECK** : *Is the resistance less than 0.5 Ω?*
- YES** : Go to step 10V2.
- NO** : Repair ABSCM&H/U ground harness.

**10V2 : CHECK POOR CONTACT IN CONNECTORS.**

- CHECK** : *Is there poor contact in connectors between battery, ignition switch and ABSCM&H/U? <Ref. to FOREWORD [W3C1].>*
- YES** : Repair connector.
- NO** : Go to step 10V3.

**10V3 : CHECK SOURCES OF SIGNAL NOISE.**

- CHECK** : *Is the car telephone or the wireless transmitter properly installed?*
- YES** : Go to step 10V4.
- NO** : Properly install the car telephone or the wireless transmitter.

**10V4 : CHECK SOURCES OF SIGNAL NOISE.**

- CHECK** : *Are noise sources (such as an antenna) installed near the sensor harness?*
- YES** : Install the noise sources apart from the sensor harness.
- NO** : Go to step 10V5.

**10V5 : CHECK ABSCM&H/U.**

- 1) Turn ignition switch to OFF.
  - 2) Connect all connectors.
  - 3) Erase the memory.
  - 4) Perform inspection mode.
  - 5) Read out the trouble code.
- CHECK** : *Is the same trouble code as in the current diagnosis still being output?*
- YES** : Replace ABSCM&H/U. <Ref. to 4-4 [W14A0].>
- NO** : Go to step 10V6.

**10V6 : CHECK ANY OTHER TROUBLE CODES APPEARANCE.**

- CHECK** : *Are other trouble codes being output?*
- YES** : Proceed with the diagnosis corresponding to the trouble code.
- NO** : A temporary poor contact.

**W: TROUBLE CODE 42 POWER SUPPLY VOLTAGE TOO LOW**  
**— POWER SUPPLY VOLTAGE TOO LOW —**

**DIAGNOSIS:**

- Power source voltage of the ABSCM&H/U is low.

**TROUBLE SYMPTOM:**

- ABS does not operate.

**WIRING DIAGRAM:**

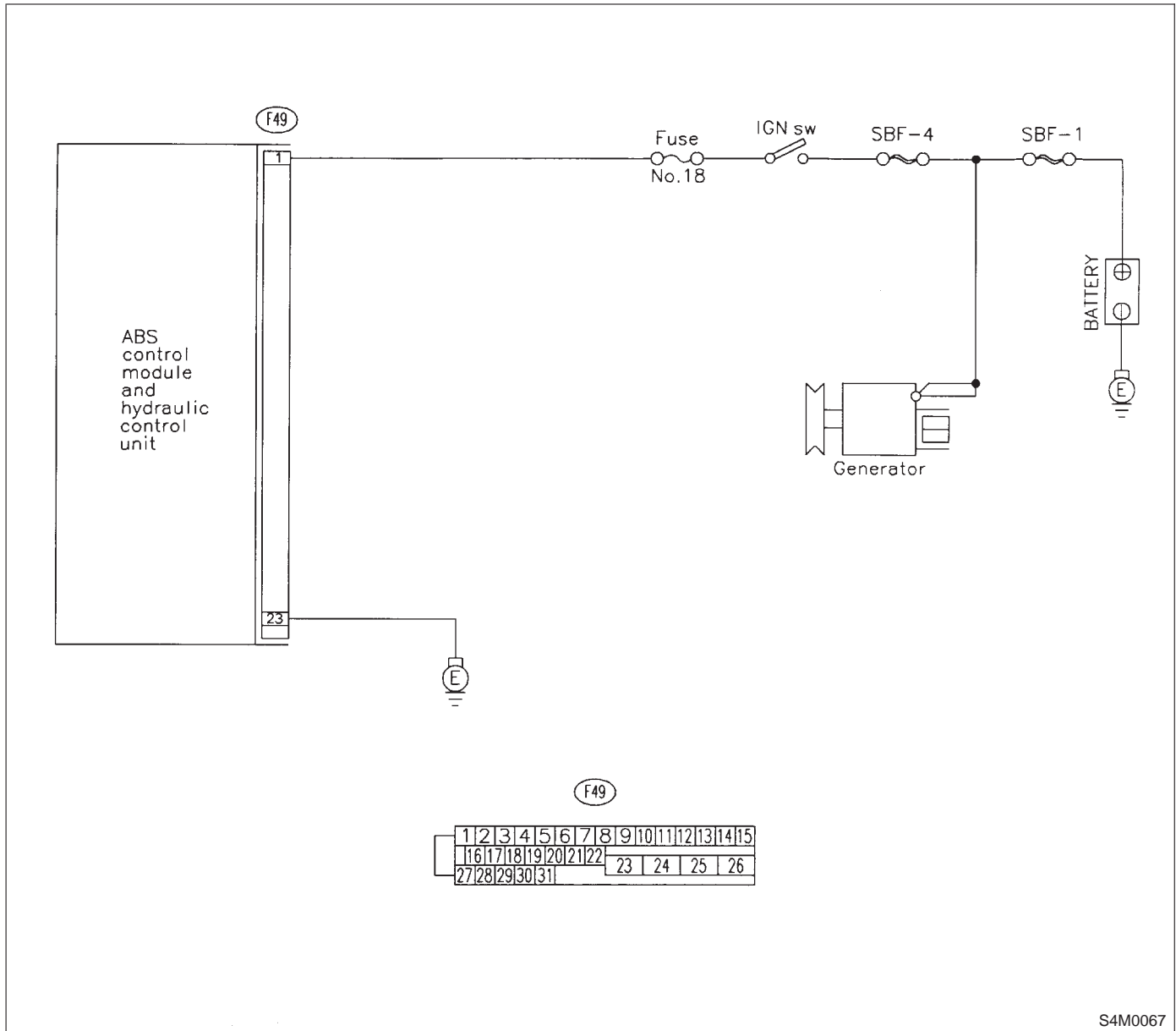

**10W1 : CHECK GENERATOR.**

- 1) Start engine.
- 2) Idling after warm-up.
- 3) Measure voltage between generator B terminal and chassis ground.

**Terminals**

**Generator B terminal — Chassis ground:**

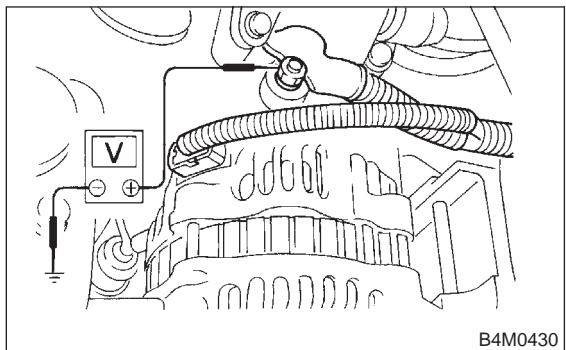

- CHECK** : *Is the voltage between 10 and 15 V?*
- YES** : Go to step 10W2.
- NO** : Repair generator. <Ref. to 6-1 [W2A0].>

**10W2 : CHECK BATTERY TERMINAL.**

Turn ignition switch to OFF.

- CHECK** : *Are the positive and negative battery terminals tightly clamped?*
- YES** : Go to step 10W3.
- NO** : Tighten the clamp of terminal.

**10W3 : CHECK INPUT VOLTAGE OF ABSCM&H/U.**

- 1) Disconnect connector from ABSCM&H/U.
- 2) Run the engine at idle.
- 3) Measure voltage between ABSCM&H/U connector and chassis ground.

**Connector & terminal**

**(F49) No. 1 (+) — Chassis ground (-):**

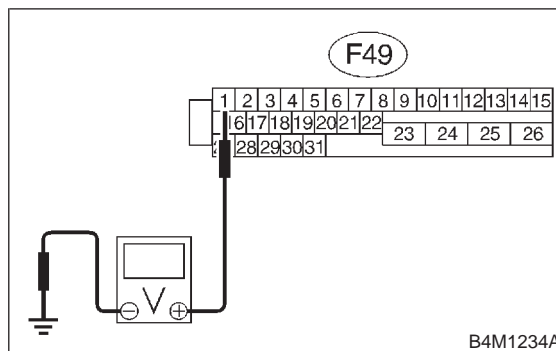

- CHECK** : *Is the voltage between 10 and 15 V?*
- YES** : Go to step 10W4.
- NO** : Repair harness connector between battery, ignition switch and ABSCM&H/U.

**10W4 : CHECK GROUND CIRCUIT OF ABSCM&H/U.**

- 1) Turn ignition switch to OFF.
- 2) Measure resistance between ABSCM&H/U connector and chassis ground.

**Connector & terminal**

**(F49) No. 23 — Chassis ground:**

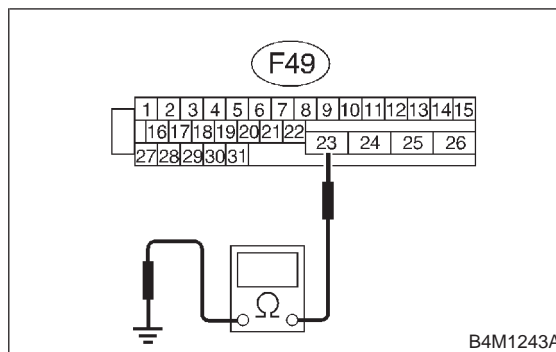

- CHECK** : *Is the resistance less than 0.5 Ω?*
- YES** : Go to step 10W5.
- NO** : Repair ABSCM&H/U ground harness.

**10W5 : CHECK POOR CONTACT IN CONNECTORS.**

**CHECK** : *Is there poor contact in connectors between generator, battery and ABSCM&H/U? <Ref. to FOREWORD [W3C1].>*

**YES** : Repair connector.

**NO** : Go to step **10W6**.

**10W6 : CHECK ABSCM&H/U.**

- 1) Connect all connectors.
- 2) Erase the memory.
- 3) Perform inspection mode.
- 4) Read out the trouble code.

**CHECK** : *Is the same trouble code as in the current diagnosis still being output?*

**YES** : Replace ABSCM&H/U. <Ref. to 4-4 [W14A0].>

**NO** : Go to step **10W7**.

**10W7 : CHECK ANY OTHER TROUBLE CODES APPEARANCE.**

**CHECK** : *Are other trouble codes being output?*

**YES** : Proceed with the diagnosis corresponding to the trouble code.

**NO** : A temporary poor contact.



MEMO:

**X: TROUBLE CODE 42 POWER SUPPLY VOLTAGE TOO HIGH  
— POWER SUPPLY VOLTAGE TOO HIGH —**

**DIAGNOSIS:**

- Power source voltage of the ABSCM&H/U is high.

**TROUBLE SYMPTOM:**

- ABS does not operate.

**WIRING DIAGRAM:**

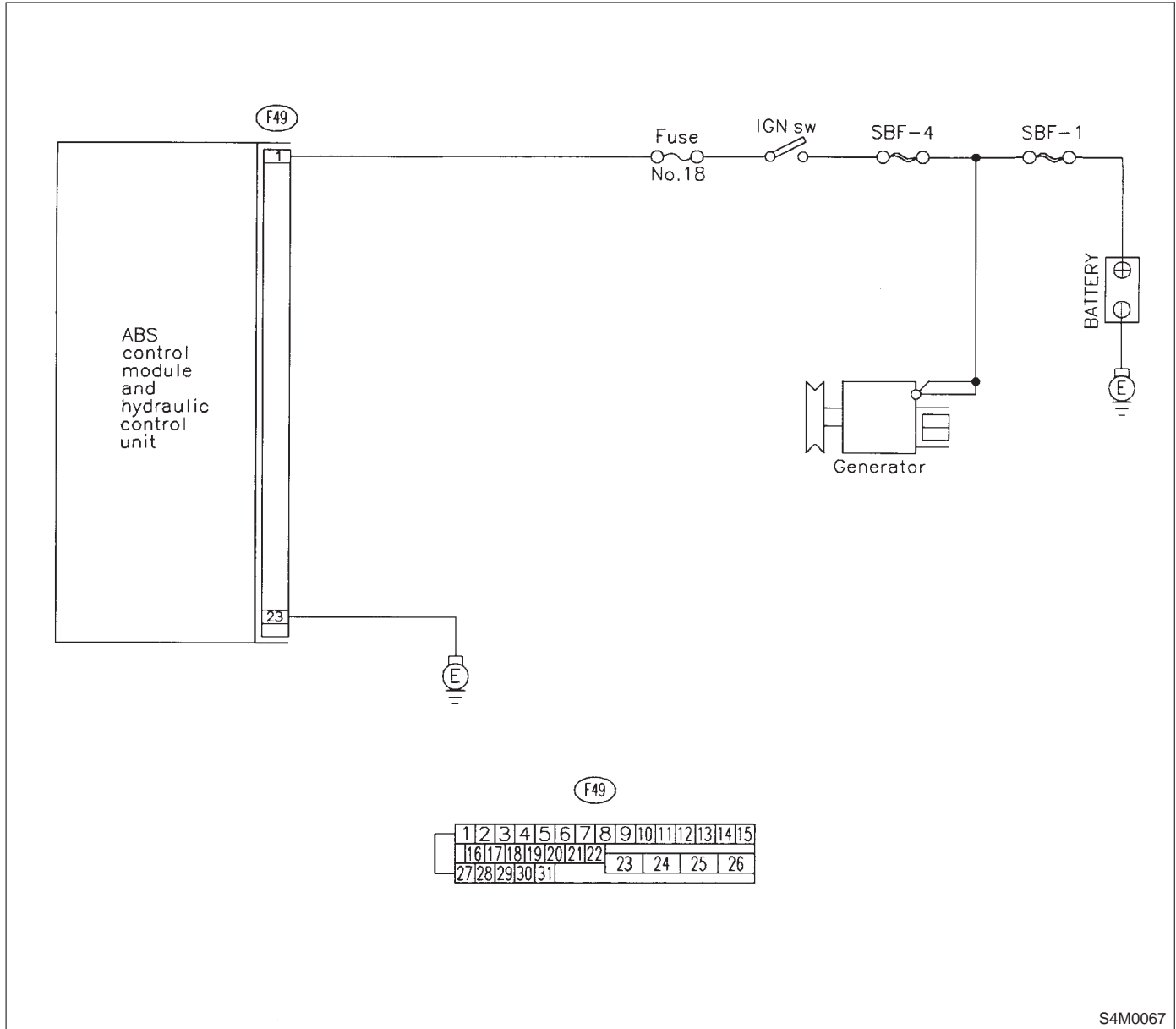

S4M0067

**10X1 : CHECK GENERATOR.**

- 1) Start engine.
- 2) Idling after warm-up.
- 3) Measure voltage between generator B terminal and chassis ground.

**Terminals**

**Generator B terminal — Chassis ground:**

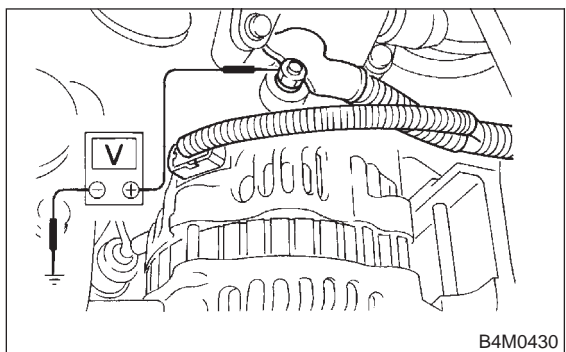

- CHECK** : *Is the voltage between 10 and 15 V?*
- YES** : Go to step 10X2.
- NO** : Repair generator. <Ref. to 6-1 [W2A0].>

**10X2 : CHECK BATTERY TERMINAL.**

Turn ignition switch to OFF.

- CHECK** : *Are the positive and negative battery terminals tightly clamped?*
- YES** : Go to step 10X3.
- NO** : Tighten the clamp of terminal.

**10X3 : CHECK INPUT VOLTAGE OF ABSCM&H/U.**

- 1) Disconnect connector from ABSCM&H/U.
- 2) Run the engine at idle.
- 3) Measure voltage between ABSCM&H/U connector and chassis ground.

**Connector & terminal**

**(F49) No. 1 (+) — Chassis ground (-):**

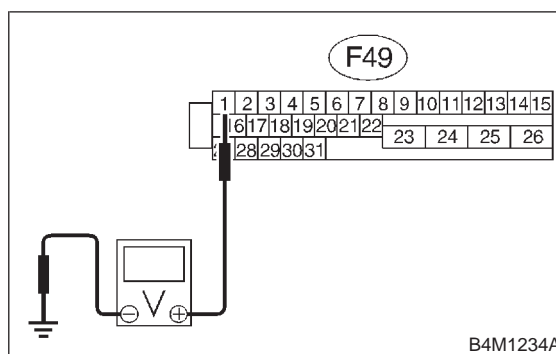

- CHECK** : *Is the voltage between 10 and 15 V?*
- YES** : Go to step 10X4.
- NO** : Repair harness connector between battery, ignition switch and ABSCM&H/U.

**10X4 : CHECK GROUND CIRCUIT OF ABSCM&H/U.**

- 1) Turn ignition switch to OFF.
- 2) Measure resistance between ABSCM&H/U connector and chassis ground.

**Connector & terminal**

**(F49) No. 23 — Chassis ground:**

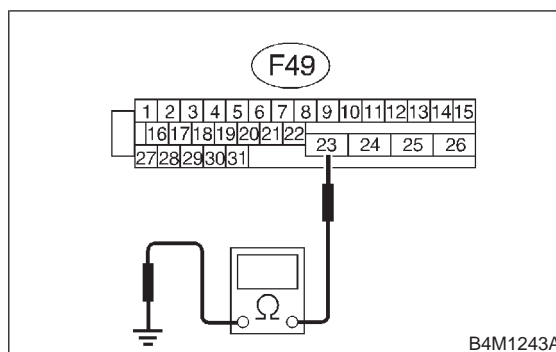

- CHECK** : *Is the resistance less than 0.5 Ω?*
- YES** : Go to step 10X5.
- NO** : Repair ABSCM&H/U ground harness.

**10X5 : CHECK POOR CONTACT IN CONNECTORS.**

**CHECK** : *Is there poor contact in connectors between generator, battery and ABSCM&H/U? <Ref. to FOREWORD [W3C1].>*

**YES** : Repair connector.

**NO** : Go to step **10X6**.

**10X6 : CHECK ABSCM&H/U.**

- 1) Connect all connectors.
- 2) Erase the memory.
- 3) Perform inspection mode.
- 4) Read out the trouble code.

**CHECK** : *Is the same trouble code as in the current diagnosis still being output?*

**YES** : Replace ABSCM&H/U. <Ref. to 4-4 [W14A0].>

**NO** : Go to step **10X7**.

**10X7 : CHECK ANY OTHER TROUBLE CODES APPEARANCE.**

**CHECK** : *Are other trouble codes being output?*

**YES** : Proceed with the diagnosis corresponding to the trouble code.

**NO** : A temporary poor contact.

**MEMO:**

**Y: TROUBLE CODE 44 ABS-AT CONTROL (NON CONTROLLED)**  
**— ABS-AT CONTROL (NON CONTROLLED) —**

**DIAGNOSIS:**

- Combination of AT control faults

**TROUBLE SYMPTOM:**

- ABS does not operate.

**WIRING DIAGRAM:**

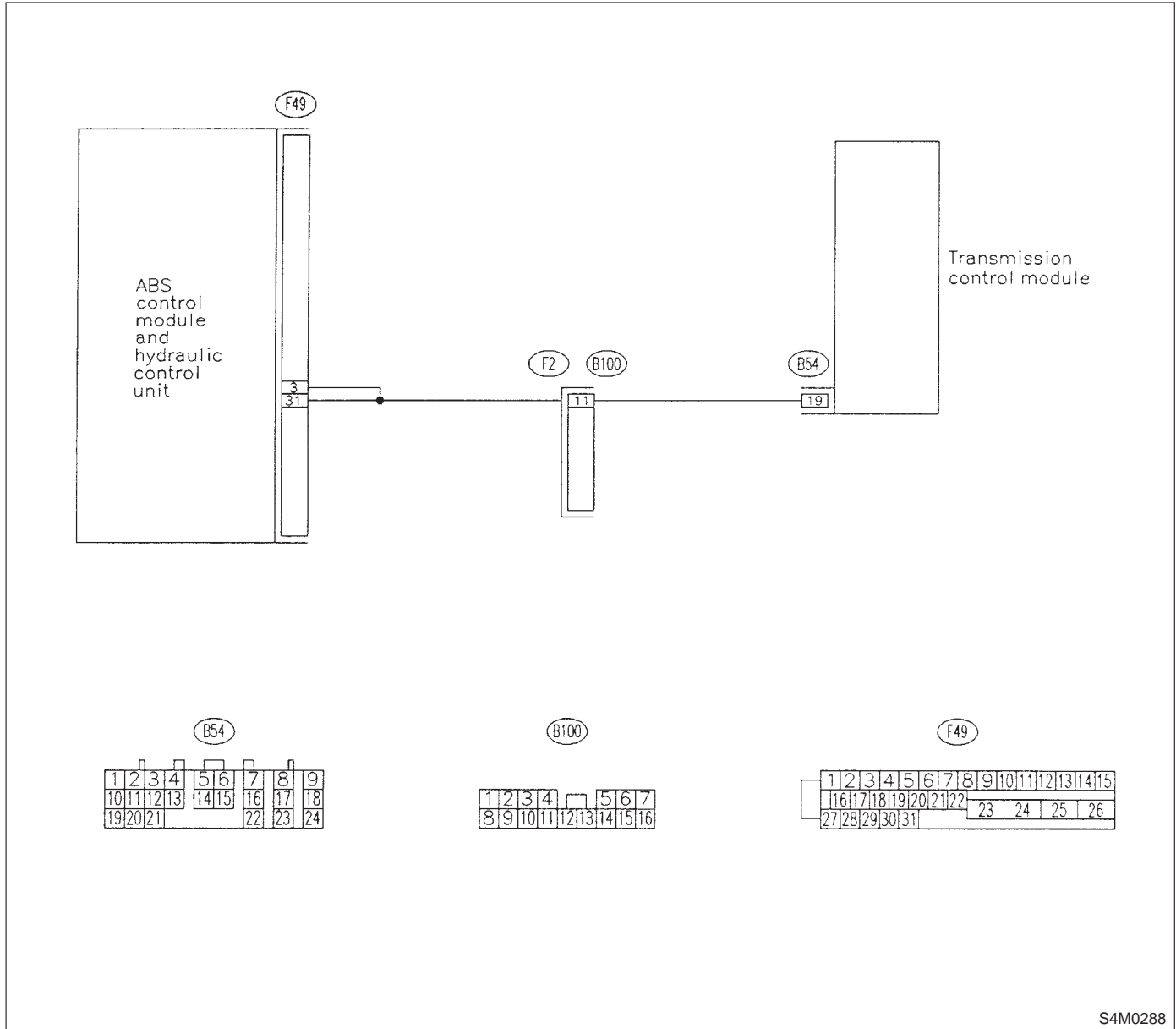

S4M0288

**10Y1 : CHECK SPECIFICATIONS OF THE ABSCM&H/U.**

Check specifications of the mark to the ABSCM&H/U.

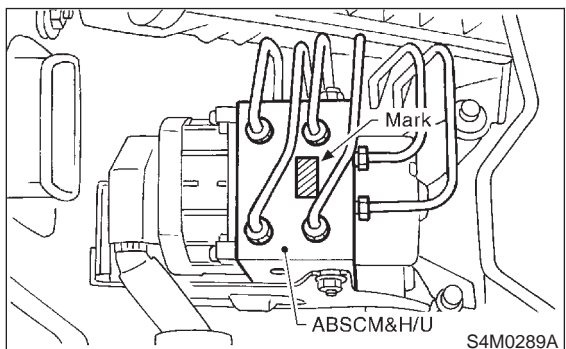

Mark	Model
C7	AWD AT
C8	AWD MT

- CHECK** : *Is an ABSCM&H/U for AT model installed on a MT model?*
- YES** : Replace ABSCM&H/U. <Ref. to 4-4 [W14A0].>
- NO** : Go to step 10Y2.

**10Y2 : CHECK GROUND SHORT OF HARNESS.**

- 1) Turn ignition switch to OFF.
- 2) Disconnect the two connectors from TCM.
- 3) Disconnect connector from ABSCM&H/U.
- 4) Measure resistance between ABSCM&H/U connector and chassis ground.

**Connector & terminal**

**(F49) No. 3 — Chassis ground:**

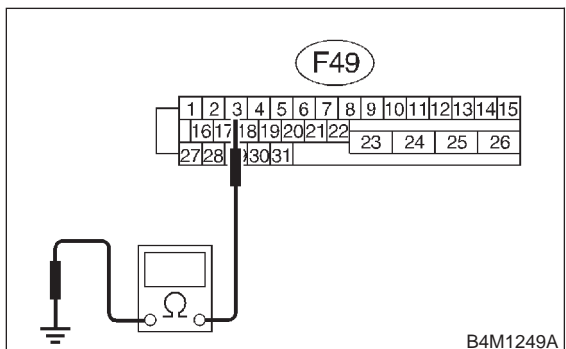

- CHECK** : *Is the resistance more than 1 MΩ?*
- YES** : Go to step 10Y3.
- NO** : Repair harness between TCM and ABSCM&H/U.

**10Y3 : CHECK TCM.**

- 1) Connect all connectors to TCM.
- 2) Turn ignition switch to ON.
- 3) Measure voltage between TCM connector terminal and chassis ground.

**Connector & terminal**

**(B54) No. 19 (+) — Chassis ground (-):**

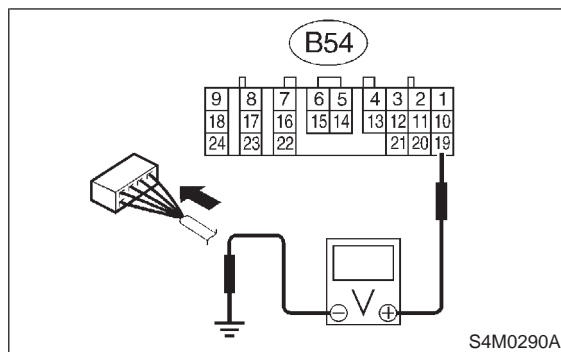

- CHECK** : *Is the voltage between 6 and 15 V?*
- YES** : Go to step 10Y5.
- NO** : Go to step 10Y4.

**10Y4 : CHECK AT.**

- CHECK** : *Is the AT functioning normally?*
- YES** : Replace TCM. <Ref. to 3-2 [W23A0].>
- NO** : Repair AT. <Ref. to 3-2 [T100].>

**10Y5 : CHECK OPEN CIRCUIT OF HARNESS.**

Measure voltage between ABSCM&H/U connector and chassis ground.

**Connector & terminal**

**(F49) No. 3 (+) — Chassis ground (-):**

**(F49) No. 31 (+) — Chassis ground (-):**

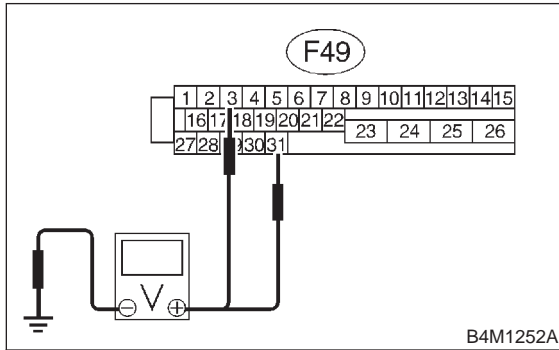

- CHECK** : *Is the voltage between 5.5 and 15 V?*
- YES** : Go to step **10Y6**.
- NO** : Repair harness/connector between TCM and ABSCM&H/U.

**10Y6 : CHECK POOR CONTACT IN CONNECTORS.**

- CHECK** : *Is there poor contact in connectors between TCM and ABSCM&H/U? <Ref. to FOREWORD [W3C1].>*
- YES** : Repair connector.
- NO** : Go to step **10Y7**.

**10Y7 : CHECK ABSCM&H/U.**

- 1) Connect all connectors.
- 2) Erase the memory.
- 3) Perform inspection mode.
- 4) Read out the trouble code.

- CHECK** : *Is the same trouble code as in the current diagnosis still being output?*
- YES** : Replace ABSCM&H/U. <Ref. to 4-4 [W14A0].>
- NO** : Go to step **10Y8**.

**10Y8 : CHECK ANY OTHER TROUBLE CODES APPEARANCE.**

- CHECK** : *Are other trouble codes being output?*
- YES** : Proceed with the diagnosis corresponding to the trouble code.
- NO** : A temporary poor contact.



**MEMO:**

**Z: TROUBLE CODE 44 ABS-AT CONTROL (CONTROLLED)**  
**— ABS-AT CONTROL (CONTROLLED) —**

**DIAGNOSIS:**

- Combination of AT control faults

**TROUBLE SYMPTOM:**

- ABS does not operate.

**WIRING DIAGRAM:**

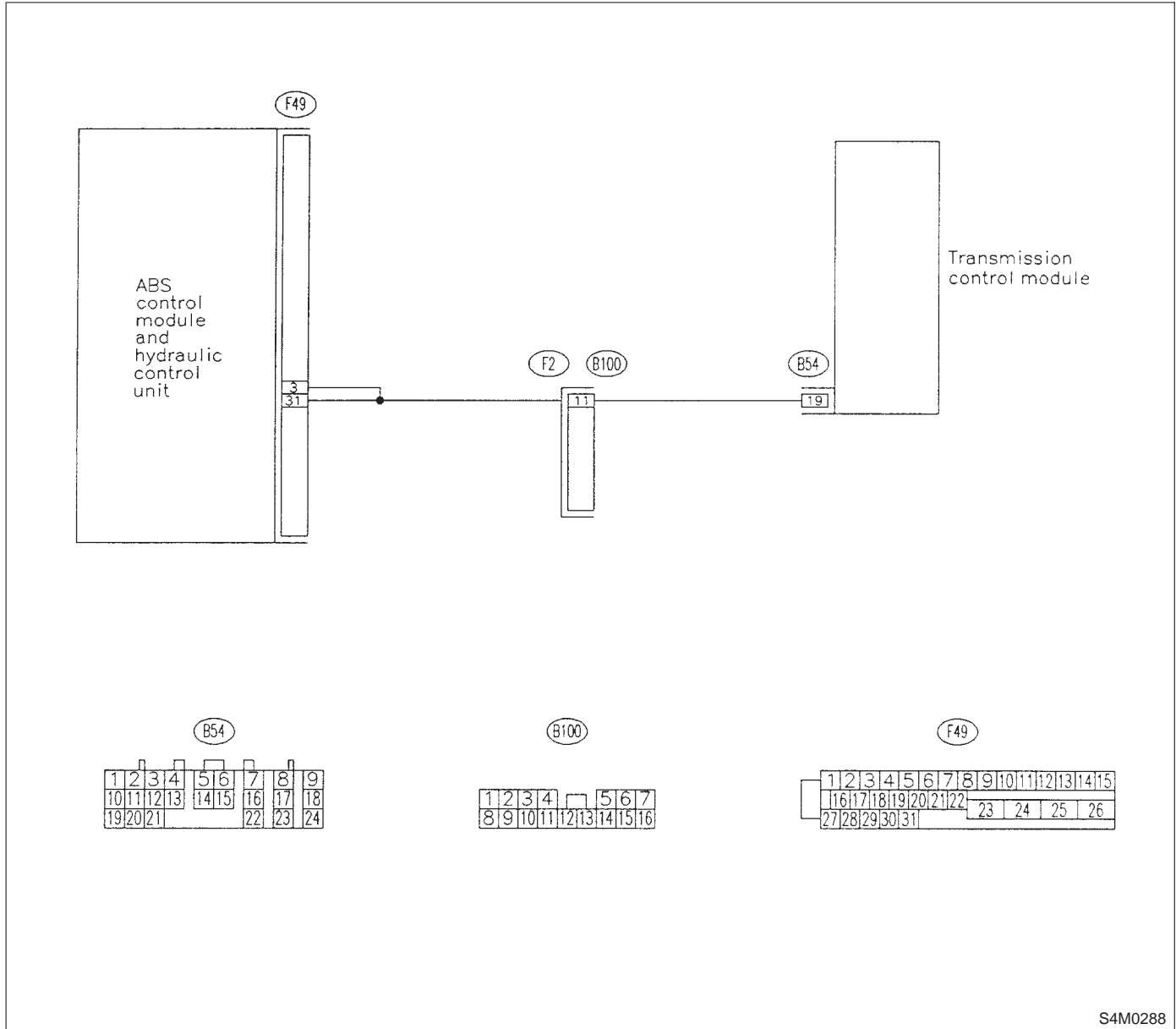

S4M0288

**10Z1 : CHECK BATTERY SHORT OF HARNESS.**

- 1) Turn ignition switch to OFF.
- 2) Disconnect the two connectors from TCM.
- 3) Disconnect connector from ABSCM&H/U.
- 4) Measure voltage between ABSCM&H/U connector and chassis ground.

**Connector & terminal**

**(F49) No. 3 (+) — Chassis ground (-):**

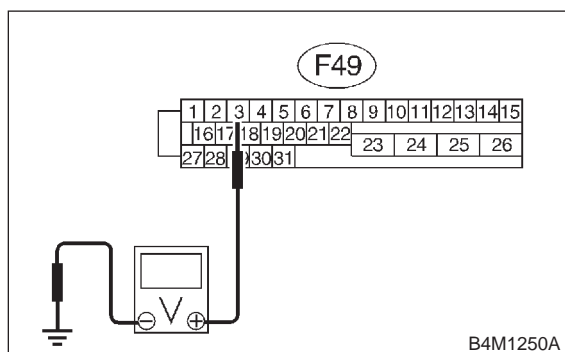

- CHECK** : *Is the voltage less than 1 V?*
- YES** : Go to step 10Z2.
- NO** : Repair harness between TCM and ABSCM&H/U.

**10Z2 : CHECK BATTERY SHORT OF HARNESS.**

- 1) Turn ignition switch to ON.
- 2) Measure voltage between ABSCM&H/U connector and chassis ground.

**Connector & terminal**

**(F49) No. 3 (+) — Chassis ground (-):**

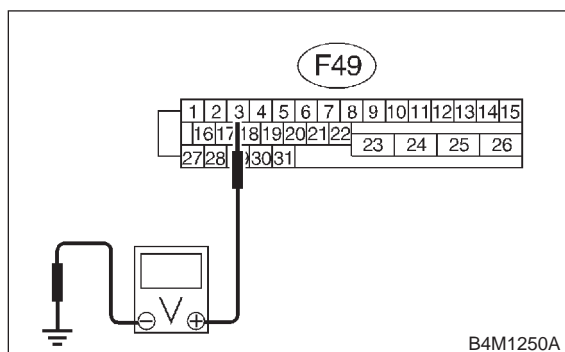

- CHECK** : *Is the voltage less than 1 V?*
- YES** : Go to step 10Z3.
- NO** : Repair harness between TCM and ABSCM&H/U.

**10Z3 : CHECK OPEN CIRCUIT OF HARNESS.**

- 1) Turn ignition switch to OFF.
- 2) Connect all connectors to TCM.
- 3) Turn ignition switch to ON.
- 4) Measure voltage between ABSCM&H/U connector and chassis ground.

**Connector & terminal**

**(F49) No. 3 (+) — Chassis ground (-):**  
**(F49) No. 31 (+) — Chassis ground (-):**

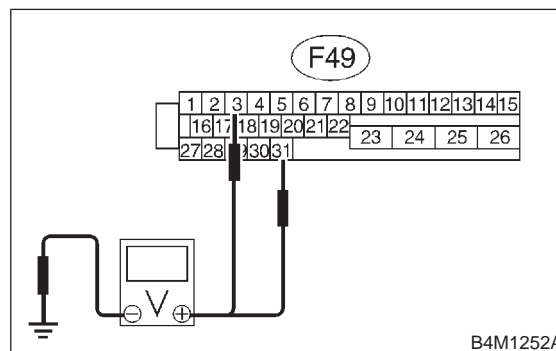

- CHECK** : *Is the voltage between 5.5 and 15 V?*
- YES** : Go to step 10Z4.
- NO** : Repair harness/connector between TCM and ABSCM&H/U.

**10Z4 : CHECK POOR CONTACT IN CONNECTORS.**

Turn ignition switch to OFF.

- CHECK** : *Is there poor contact in connectors between TCM and ABSCM&H/U? <Ref. to FOREWORD [W3C1].>*
- YES** : Repair connector.
- NO** : Go to step 10Z5.

**10Z5 : CHECK ABSCM&H/U.**

- 1) Connect all connectors.
- 2) Erase the memory.
- 3) Perform inspection mode.
- 4) Read out the trouble code.

- CHECK** : *Is the same trouble code as in the current diagnosis still being output?*
- YES** : Replace ABSCM&H/U. <Ref. to 4-4 [W14A0].>
- NO** : Go to step 10Z6.

**10Z6 : CHECK ANY OTHER TROUBLE CODES APPEARANCE.**

**CHECK** : *Are other trouble codes being output?*

**YES** : Proceed with the diagnosis corresponding to the trouble code.

**NO** : A temporary poor contact.

**MEMO:**

**AA: TROUBLE CODE 51 VALVE RELAY MALFUNCTION  
— VALVE RELAY MALFUNCTION —**

**DIAGNOSIS:**

- Faulty valve relay

**TROUBLE SYMPTOM:**

- ABS does not operate.

**WIRING DIAGRAM:**

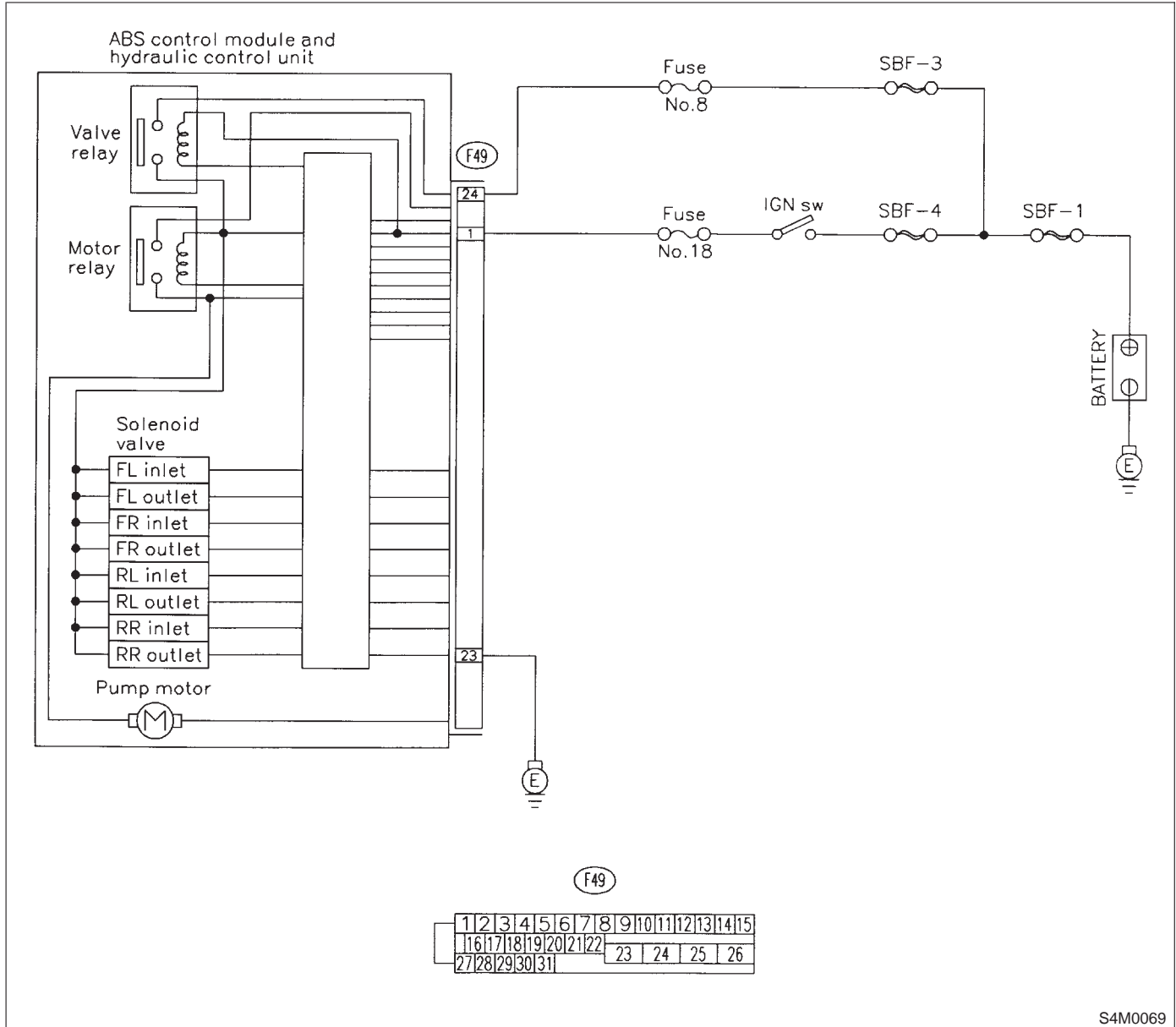

S4M0069

**10AA1 : CHECK INPUT VOLTAGE OF ABSCM&H/U.**

- 1) Turn ignition switch to OFF.
- 2) Disconnect connector from ABSCM&H/U.
- 3) Run the engine at idle.
- 4) Measure voltage between ABSCM&H/U connector and chassis ground.

**Connector & terminal**

**(F49) No. 1 (+) — Chassis ground (-):**  
**(F49) No. 24 (+) — Chassis ground (-):**

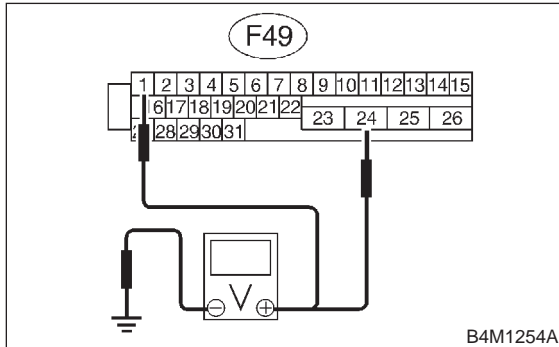

- CHECK** : *Is the voltage between 10 and 15 V?*
- YES** : Go to step 10AA2.
- NO** : Repair harness connector between battery and ABSCM&H/U.

**10AA2 : CHECK GROUND CIRCUIT OF ABSCM&H/U.**

- 1) Turn ignition switch to OFF.
- 2) Measure resistance between ABSCM&H/U connector and chassis ground.

**Connector & terminal**

**(F49) No. 23 — Chassis ground:**

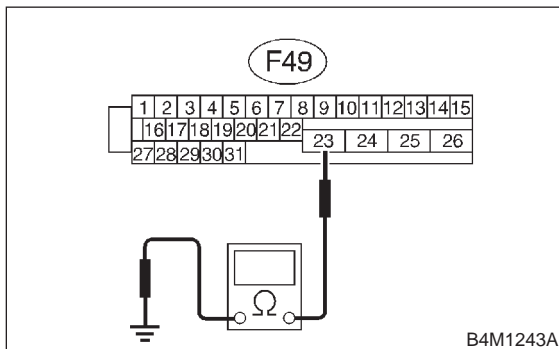

- CHECK** : *Is the resistance less than 0.5 Ω?*
- YES** : Go to step 10AA3.
- NO** : Repair ABSCM&H/U ground harness.

**10AA3 : CHECK POOR CONTACT IN CONNECTORS.**

**CHECK** : *Is there poor contact in connectors between generator, battery and ABSCM&H/U? <Ref. to FOREWORD [W3C1].>*

- YES** : Repair connector.
- NO** : Go to step 10AA4.

**10AA4 : CHECK ABSCM&H/U.**

- 1) Connect all connectors.
- 2) Erase the memory.
- 3) Perform inspection mode.
- 4) Read out the trouble code.

**CHECK** : *Is the same trouble code as in the current diagnosis still being output?*

- YES** : Replace ABSCM&H/U. <Ref. to 4-4 [W14A0].>
- NO** : Go to step 10AA5.

**10AA5 : CHECK ANY OTHER TROUBLE CODES APPEARANCE.**

**CHECK** : *Are other trouble codes being output?*

- YES** : Proceed with the diagnosis corresponding to the trouble code.
- NO** : A temporary poor contact.

**AB: TROUBLE CODE 51 VALVE RELAY ON FAILURE**  
**— VALVE RELAY ON FAILURE —**

**DIAGNOSIS:**

- Faulty valve relay

**TROUBLE SYMPTOM:**

- ABS does not operate.

**WIRING DIAGRAM:**

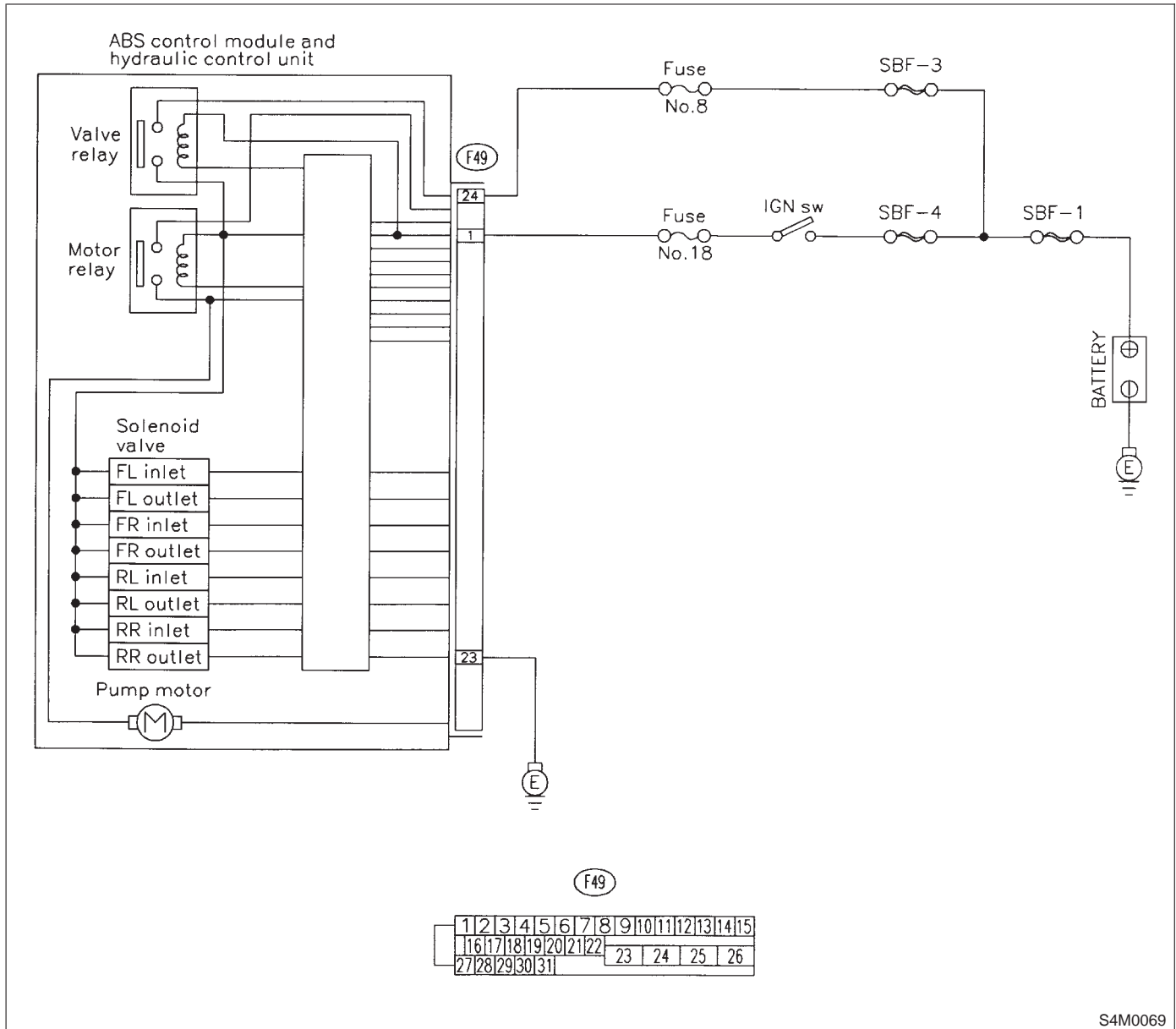

S4M0069



**10AB1 : CHECK VALVE RELAY IN ABSCM&H/U.**

Measure resistance between ABSCM&H/U terminals.

**Terminals**

**No. 23 (+) — No. 24 (-):**

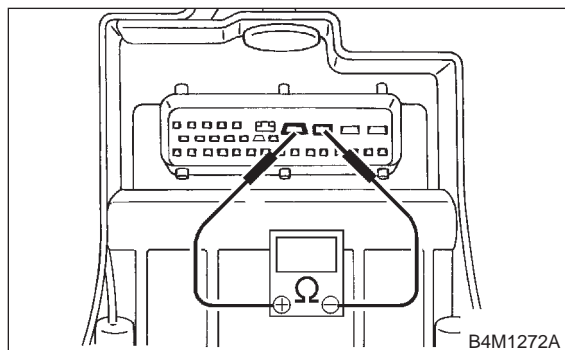

- CHECK** : *Is the resistance more than 1 MΩ?*
- YES** : Go to step **10AB2**.
- NO** : Replace ABSCM&H/U. <Ref. to 4-4 [W14A0].>

**10AB2 : CHECK POOR CONTACT IN CONNECTORS.**

- CHECK** : *Is there poor contact in connectors between generator, battery and ABSCM&H/U? <Ref. to FOREWORD [W3C1].>*
- YES** : Repair connector.
- NO** : Go to step **10AB3**.

**10AB3 : CHECK ABSCM&H/U.**

- 1) Connect all connectors.
- 2) Erase the memory.
- 3) Perform inspection mode.
- 4) Read out the trouble code.

- CHECK** : *Is the same trouble code as in the current diagnosis still being output?*
- YES** : Replace ABSCM&H/U. <Ref. to 4-4 [W14A0].>
- NO** : Go to step **10AB4**.

**10AB4 : CHECK ANY OTHER TROUBLE CODES APPEARANCE.**

- CHECK** : *Are other trouble codes being output?*
- YES** : Proceed with the diagnosis corresponding to the trouble code.
- NO** : A temporary poor contact.

**AC: TROUBLE CODE 52 OPEN CIRCUIT IN MOTOR RELAY CIRCUIT — OPEN CIRCUIT IN MOTOR RELAY CIRCUIT —**

**DIAGNOSIS:**

- Faulty motor
- Faulty motor relay
- Faulty harness connector

**TROUBLE SYMPTOM:**

- ABS does not operate.

**WIRING DIAGRAM:**

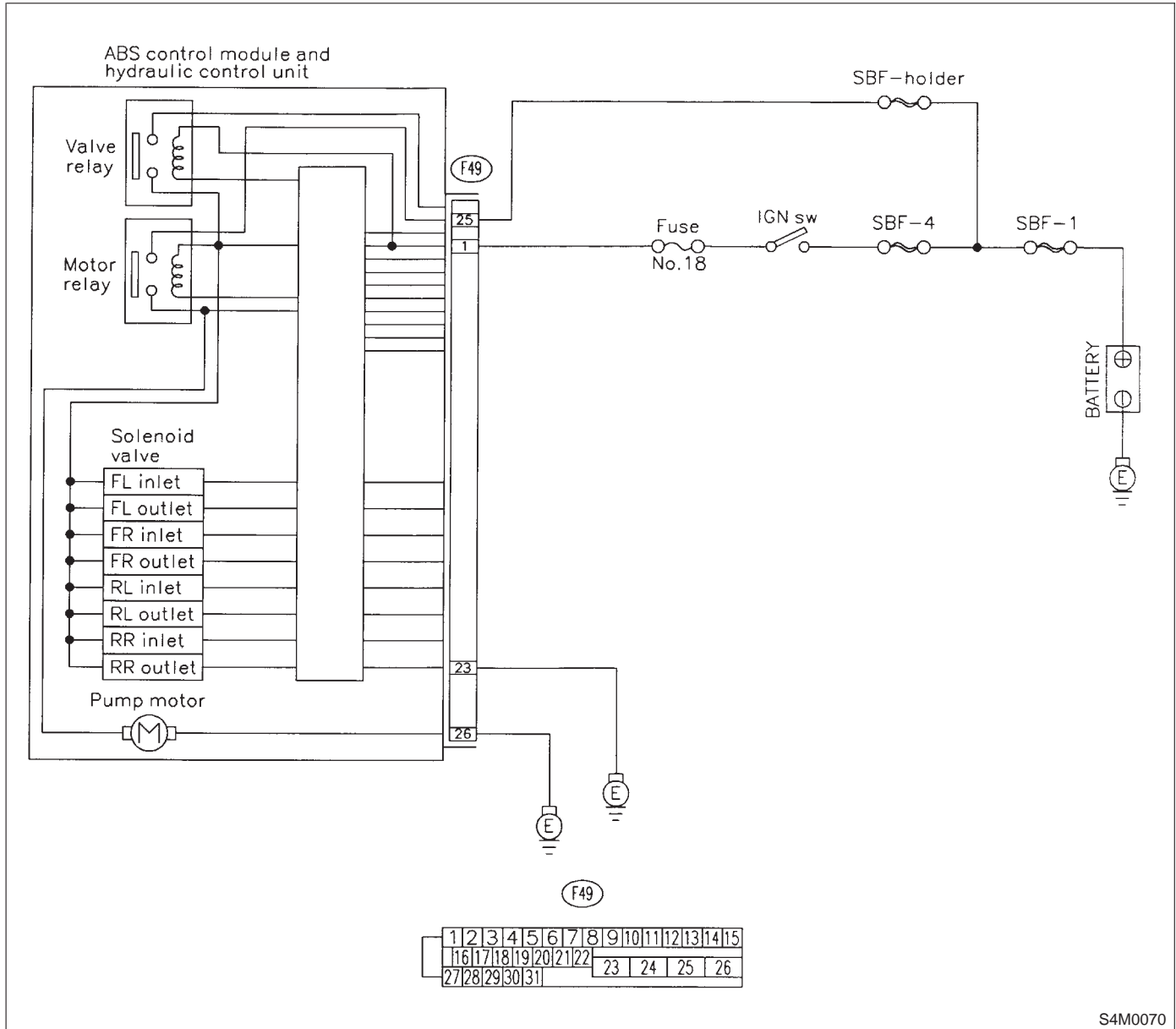

S4M0070

**10AC1 : CHECK INPUT VOLTAGE OF ABSCM&H/U.**

- 1) Turn ignition switch to OFF.
- 2) Disconnect connector from ABSCM&H/U.
- 3) Turn ignition switch to ON.
- 4) Measure voltage between ABSCM&H/U connector and chassis ground.

**Connector & terminal**  
**(F49) No. 25 (+) — Chassis ground (-):**

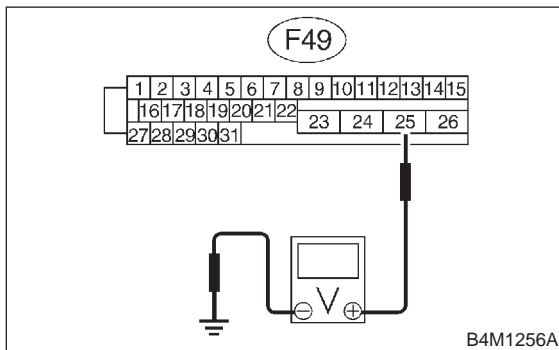

- CHECK** : *Is the voltage between 10 and 15 V?*
- YES** : Go to step **10AC2**.
- NO** : Repair harness/connector between battery and ABSCM&H/U and check fuse SBF-6.

**10AC2 : CHECK GROUND CIRCUIT OF MOTOR.**

- 1) Turn ignition switch to OFF.
- 2) Measure resistance between ABSCM&H/U connector and chassis ground.

**Connector & terminal**  
**(F49) No. 26 — Chassis ground:**

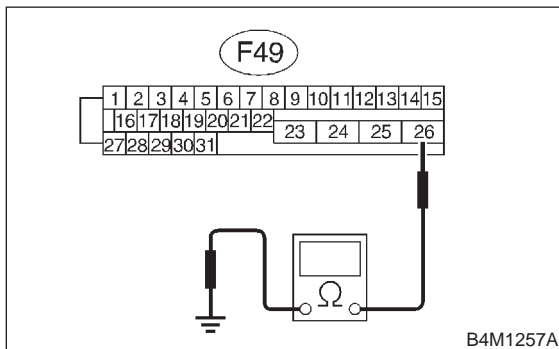

- CHECK** : *Is the resistance less than 0.5 Ω?*
- YES** : Go to step **10AC3**.
- NO** : Repair ABSCM&H/U ground harness.

**10AC3 : CHECK MOTOR OPERATION.**

Operate the sequence control. <Ref. to 4-4 [W14D1].>

NOTE:

Use the diagnosis connector to operate the sequence control.

**CHECK** : *Can motor revolution noise (buzz) be heard when carrying out the check sequence?*

**YES** : Go to step **10AC4**.

**NO** : Replace ABSCM&H/U. <Ref. to 4-4 [W14A0].>

**10AC4 : CHECK POOR CONTACT IN CONNECTORS.**

Turn ignition switch to OFF.

**CHECK** : *Is there poor contact in connector between hydraulic unit, relay box and ABSCM&H/U? <Ref. to FOREWORD [W3C1].>*

**YES** : Repair connector.

**NO** : Go to step **10AC5**.

**10AC5 : CHECK ABSCM&H/U.**

- 1) Connect all connectors.
- 2) Erase the memory.
- 3) Perform inspection mode.
- 4) Read out the trouble code.

**CHECK** : *Is the same trouble code as in the current diagnosis still being output?*

**YES** : Replace ABSCM&H/U. <Ref. to 4-4 [W14A0].>

**NO** : Go to step **10AC6**.

**10AC6 : CHECK ANY OTHER TROUBLE CODES APPEARANCE.**

**CHECK** : *Are other trouble codes being output?*

**YES** : Proceed with the diagnosis corresponding to the trouble code.

**NO** : A temporary poor contact.

**AD: TROUBLE CODE 52 MOTOR RELAY ON FAILURE**  
**— MOTOR RELAY ON FAILURE —**

**DIAGNOSIS:**

- Faulty motor
- Faulty motor relay
- Faulty harness connector

**TROUBLE SYMPTOM:**

- ABS does not operate.

**WIRING DIAGRAM:**

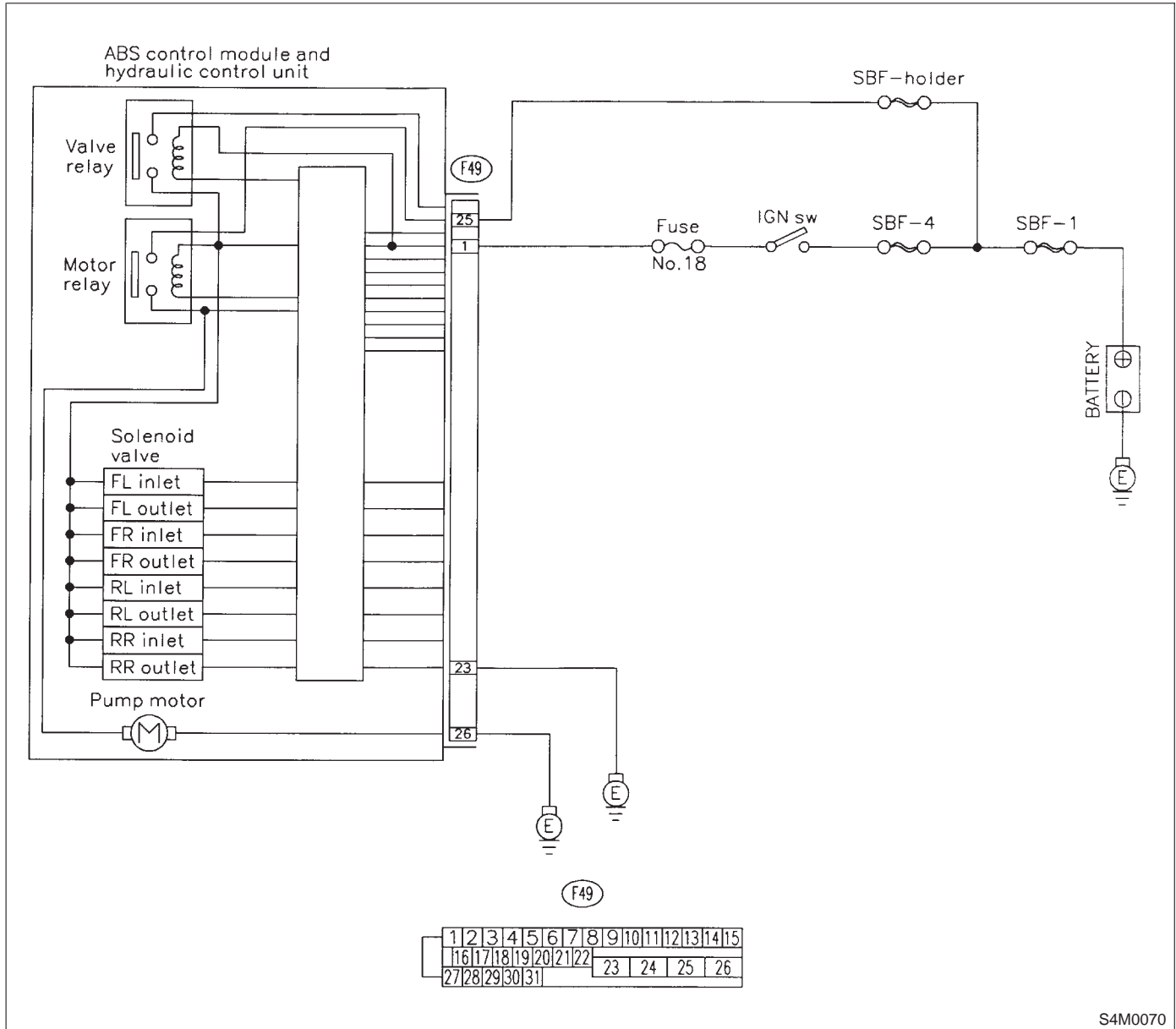

S4M0070

**10AD1 : CHECK MOTOR RELAY IN ABSCM&H/U.**

Measure resistance between ABSCM&H/U terminals.

**Terminals**

**No. 25 — No. 26:**

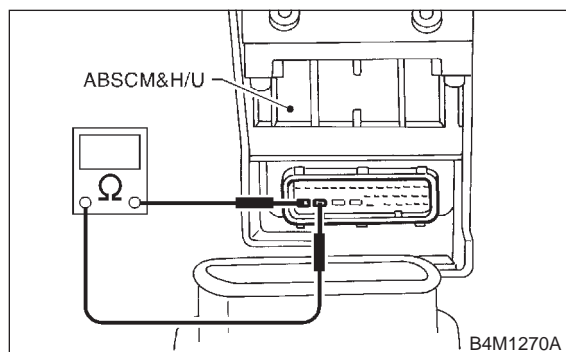

- CHECK** : *Is the resistance more than 1 MΩ?*  
**YES** : Go to step **10AD2**.  
**NO** : Replace ABSCM&H/U. <Ref. to 4-4 [W14A0].>

**10AD2 : CHECK MOTOR OPERATION.**

Operate the sequence control. <Ref. to 4-4 [W14D1].>

**NOTE:**

Use the diagnosis connector to operate the sequence control.

- CHECK** : *Can motor revolution noise (buzz) be heard when carrying out the sequence control?*  
**YES** : Go to step **10AD3**.  
**NO** : Replace ABSCM&H/U. <Ref. to 4-4 [W14A0].>

**10AD3 : CHECK POOR CONTACT IN CONNECTORS.**

Turn ignition switch to OFF.

- CHECK** : *Is there poor contact in connector between hydraulic unit, relay box and ABSCM&H/U? <Ref. to FOREWORD [W3C1].>*  
**YES** : Repair connector.  
**NO** : Go to step **10AD4**.

**10AD4 : CHECK ABSCM&H/U.**

- 1) Connect all connectors.
- 2) Erase the memory.
- 3) Perform inspection mode.
- 4) Read out the trouble code.

- CHECK** : *Is the same trouble code as in the current diagnosis still being output?*  
**YES** : Replace ABSCM&H/U. <Ref. to 4-4 [W14A0].>  
**NO** : Go to step **10AD5**.

**10AD5 : CHECK ANY OTHER TROUBLE CODES APPEARANCE.**

- CHECK** : *Are other trouble codes being output?*  
**YES** : Proceed with the diagnosis corresponding to the trouble code.  
**NO** : A temporary poor contact.

**AE: TROUBLE CODE 52 MOTOR MALFUNCTION  
— MOTOR MALFUNCTION —**

**DIAGNOSIS:**

- Faulty motor
- Faulty motor relay
- Faulty harness connector

**TROUBLE SYMPTOM:**

- ABS does not operate.

**WIRING DIAGRAM:**

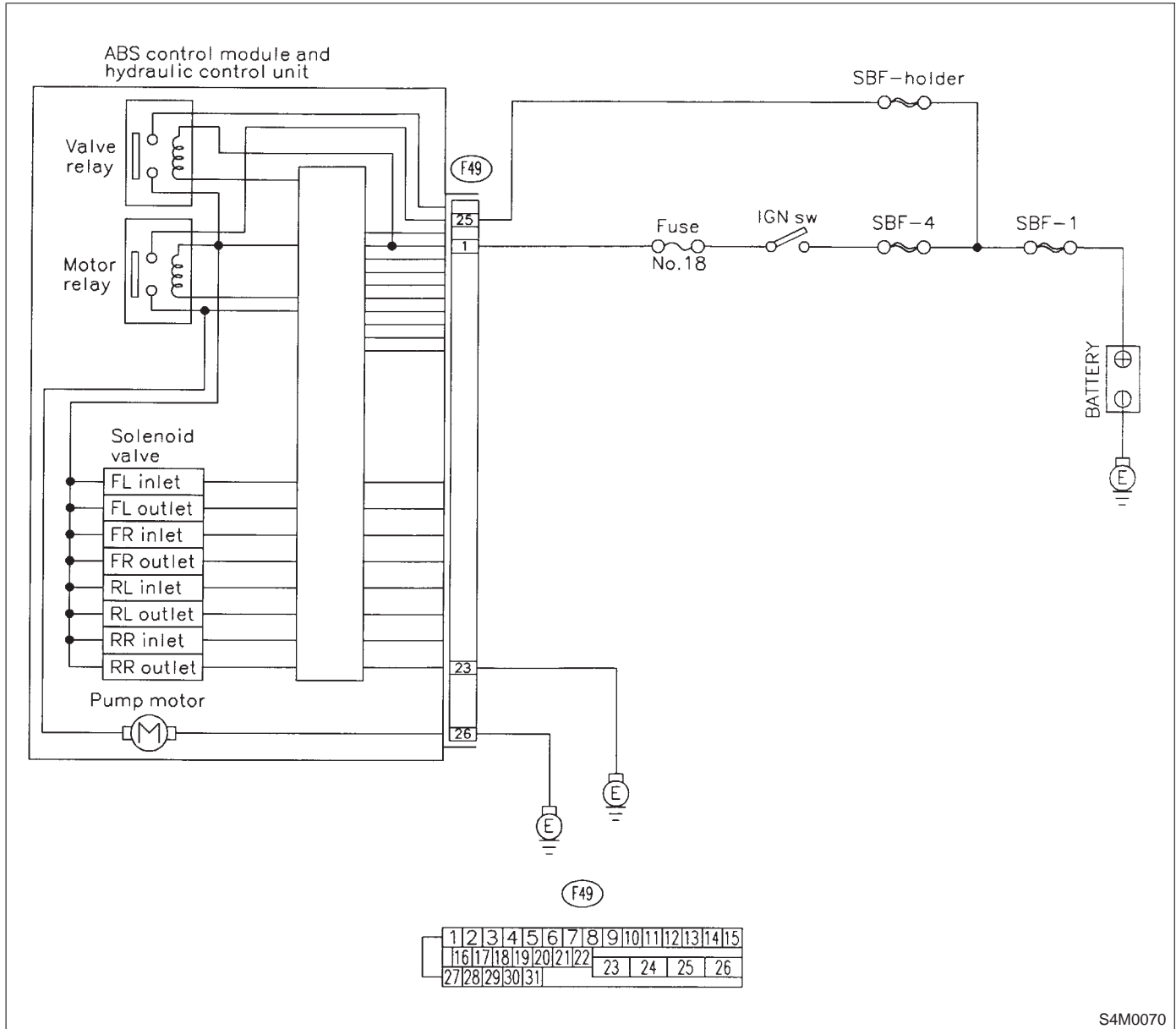

S4M0070

**10AE1 : CHECK INPUT VOLTAGE OF ABSCM&H/U.**

- 1) Turn ignition switch to OFF.
- 2) Disconnect connector from ABSCM&H/U.
- 3) Turn ignition switch to ON.
- 4) Measure voltage between ABSCM&H/U connector and chassis ground.

**Connector & terminal**

**(F49) No. 25 (+) — Chassis ground (-):**

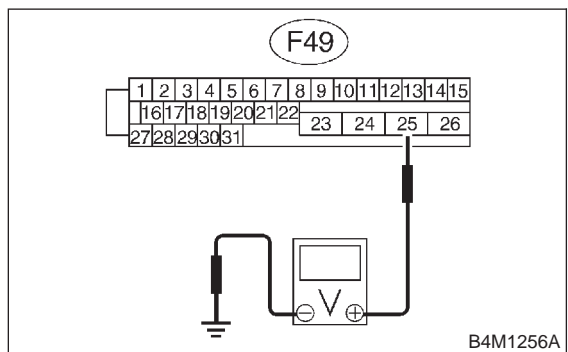

- CHECK** : Is the voltage between 10 and 15 V?
- YES** : Go to step 10AE2.
- NO** : Repair harness/connector between battery and ABSCM&H/U and check fuse SBF-6.

**10AE2 : CHECK GROUND CIRCUIT OF MOTOR.**

- 1) Turn ignition switch to OFF.
- 2) Measure resistance between ABSCM&H/U connector and chassis ground.

**Connector & terminal**

**(F49) No. 26 — Chassis ground:**

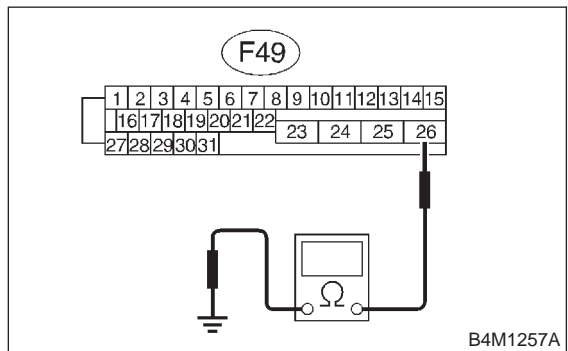

- CHECK** : Is the resistance less than 0.5 Ω?
- YES** : Go to step 10AE3.
- NO** : Repair ABSCM&H/U ground harness.

**10AE3 : CHECK INPUT VOLTAGE OF ABSCM&H/U.**

- 1) Run the engine at idle.
- 2) Measure voltage between ABSCM&H/U connector and chassis ground.

**Connector & terminal**

**(F49) No. 1 (+) — Chassis ground (-):**

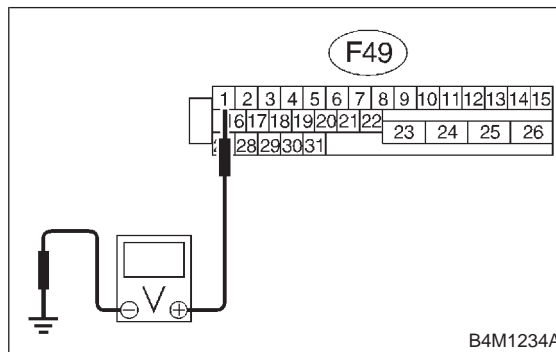

- CHECK** : Is the voltage between 10 and 15 V?
- YES** : Go to step 10AE4.
- NO** : Repair harness connector between battery, ignition switch and ABSCM&H/U.

**10AE4 : CHECK GROUND CIRCUIT OF ABSCM&H/U.**

- 1) Turn ignition switch to OFF.
- 2) Measure resistance between ABSCM&H/U connector and chassis ground.

**Connector & terminal**

**(F49) No. 23 — Chassis ground:**

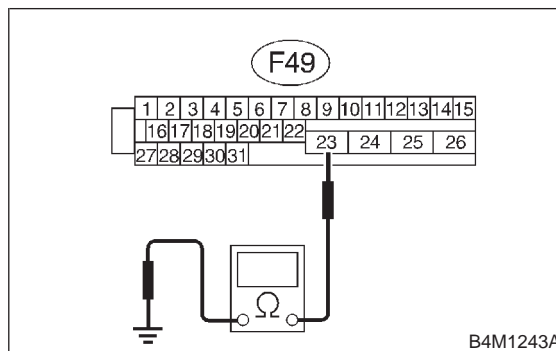

- CHECK** : Is the resistance less than 0.5 Ω?
- YES** : Go to step 10AE5.
- NO** : Repair ABSCM&H/U ground harness.

**10AE5 : CHECK MOTOR OPERATION.**

Operate the sequence control. <Ref. to 4-4 [W14D1].>

## NOTE:

Use the diagnosis connector to operate the sequence control.

**CHECK** : ***Can motor revolution noise (buzz) be heard when carrying out the sequence control?***

**YES** : Go to step **10AE6**.

**NO** : Replace ABSCM&H/U. <Ref. to 4-4 [W14A0].>

**10AE6 : CHECK POOR CONTACT IN CONNECTORS.**

Turn ignition switch to OFF.

**CHECK** : ***Is there poor contact in connector between generator, battery and ABSCM&H/U? <Ref. to FOREWORD [W3C1].>***

**YES** : Repair connector.

**NO** : Go to step **10AE7**.

**10AE7 : CHECK ABSCM&H/U.**

- 1) Connect all connectors.
- 2) Erase the memory.
- 3) Perform inspection mode.
- 4) Read out the trouble code.

**CHECK** : ***Is the same trouble code as in the current diagnosis still being output?***

**YES** : Replace ABSCM&H/U. <Ref. to 4-4 [W14A0].>

**NO** : Go to step **10AE8**.

**10AE8 : CHECK ANY OTHER TROUBLE CODES APPEARANCE.**

**CHECK** : ***Are other trouble codes being output?***

**YES** : Proceed with the diagnosis corresponding to the trouble code.

**NO** : A temporary poor contact.



MEMO:

**AF: TROUBLE CODE 54 STOP LIGHT SWITCH SIGNAL CIRCUIT MALFUNCTION**

**— STOP LIGHT SWITCH SIGNAL CIRCUIT MALFUNCTION —**

**DIAGNOSIS:**

- Faulty stop light switch

**TROUBLE SYMPTOM:**

- ABS does not operate.

**WIRING DIAGRAM:**

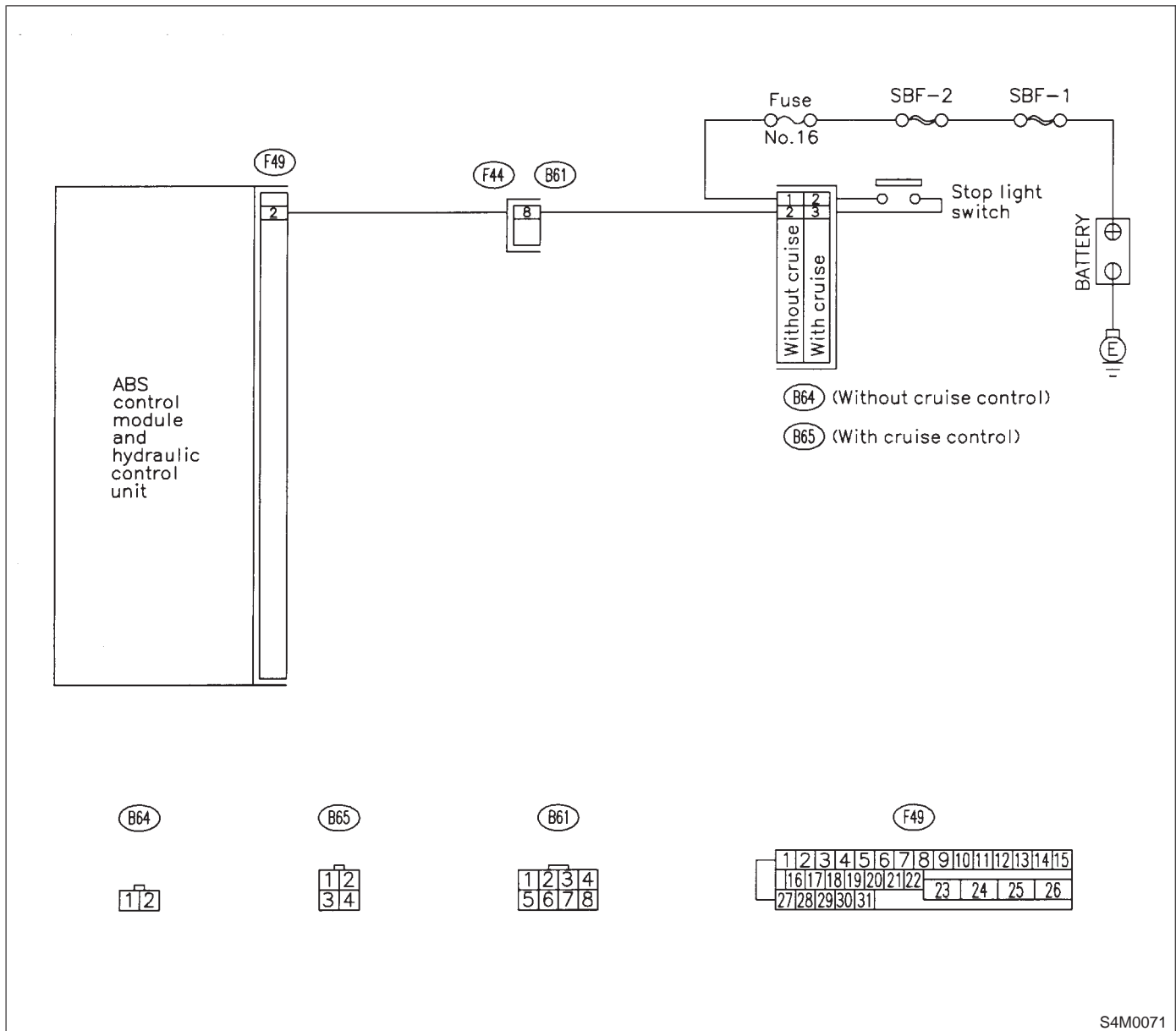

S4M0071

**10AF1 : CHECK OUTPUT OF STOP LIGHT SWITCH USING SELECT MONITOR.**

- 1) Select "Current data display & Save" on the select monitor.
- 2) Release the brake pedal.
- 3) Read the stop light switch output in the select monitor data display.

- CHECK** : *Is the reading indicated on monitor display less than 1.5 V?*
- YES** : Go to step 10AF2.
- NO** : Go to step 10AF3.

**10AF2 : CHECK OUTPUT OF STOP LIGHT SWITCH USING SELECT MONITOR.**

- 1) Depress the brake pedal.
- 2) Read the stop light switch output in the select monitor data display.

- CHECK** : *Is the reading indicated on monitor display between 10 and 15 V?*
- YES** : Go to step 10AF5.
- NO** : Go to step 10AF3.

**10AF3 : CHECK IF STOP LIGHTS COME ON.**

Depress the brake pedal.

- CHECK** : *Do stop lights turn on?*
- YES** : Go to step 10AF4.
- NO** : Repair stop lights circuit.

**10AF4 : CHECK OPEN CIRCUIT IN HARNESS.**

- 1) Turn ignition switch to OFF.
- 2) Disconnect connector from ABSCM&H/U.
- 3) Depress brake pedal.
- 4) Measure voltage between ABSCM&H/U connector and chassis ground.

**Connector & terminal**  
**(F49) No. 2 — Chassis ground:**

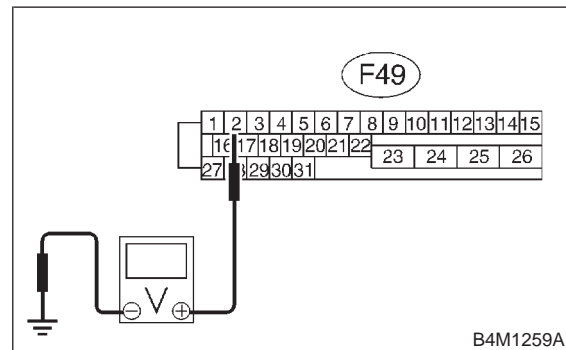

- CHECK** : *Is the voltage between 10 and 15 V?*
- YES** : Go to step 10AF5.
- NO** : Repair harness between stop light switch and ABSCM&H/U connector.

**10AF5 : CHECK POOR CONTACT IN CONNECTORS.**

- CHECK** : *Is there poor contact in connector between stop light switch and ABSCM&H/U? <Ref. to FOREWORD [W3C1].>*
- YES** : Repair connector.
- NO** : Go to step 10AF6.

**10AF6 : CHECK ABSCM&H/U.**

- 1) Connect all connectors.
  - 2) Erase the memory.
  - 3) Perform inspection mode.
  - 4) Read out the trouble code.
- CHECK** : *Is the same trouble code as in the current diagnosis still being output?*
- YES** : Replace ABSCM&H/U. <Ref. to 4-4 [W14A0].>
- NO** : Go to step 10AF7.

**10AF7 : CHECK ANY OTHER TROUBLE CODES APPEARANCE.**

- CHECK** : *Are other trouble codes being output?*
- YES** : Proceed with the diagnosis corresponding to the trouble code.
- NO** : A temporary poor contact.

**MEMO:**

**AG: TROUBLE CODE 56 OPEN OR SHORT CIRCUIT IN G SENSOR CIRCUIT — OPEN OR SHORT CIRCUIT IN G SENSOR CIRCUIT —**

**DIAGNOSIS:**

- Faulty G sensor output voltage

**TROUBLE SYMPTOM:**

- ABS does not operate.

**WIRING DIAGRAM:**

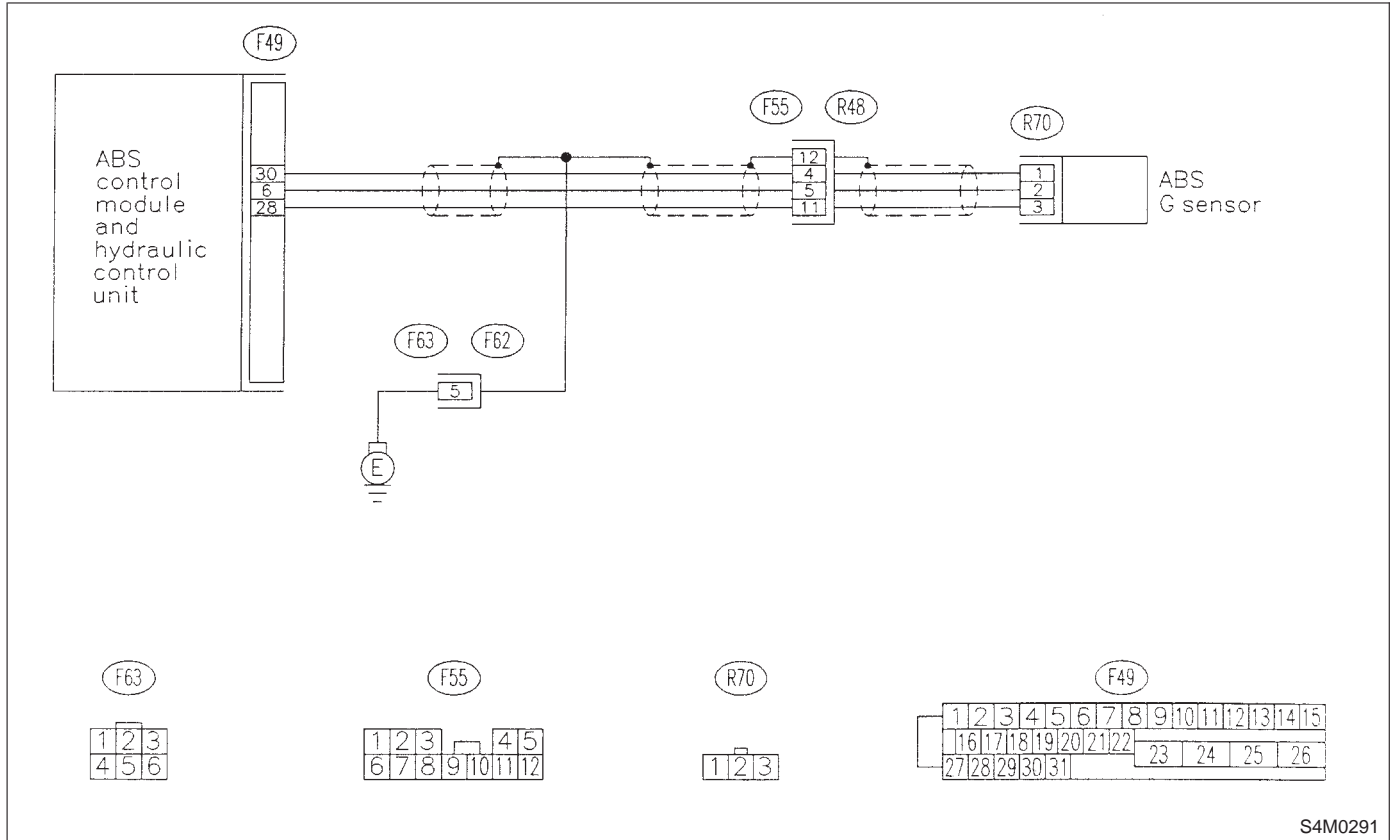

S4M0291

**10AG1 : CHECK OUTPUT OF G SENSOR USING SELECT MONITOR.**

- 1) Select "Current data display & Save" on the select monitor.
- 2) Read the G sensor output in select monitor data display.

**CHECK** : *Is the G sensor output on the monitor display between 2.1 and 2.5 V when the G sensor is in horizontal position?*

**YES** : Go to step **10AG2**.

**NO** : Go to step **10AG5**.

**10AG2 : CHECK POOR CONTACT IN CONNECTORS.**

**CHECK** : *Is there poor contact in connector between ABSCM&H/U and G sensor? <Ref. to FOREWORD [W3C1].>*

**YES** : Repair connector.

**NO** : Go to step **10AG3**.

**10AG3 : CHECK ABSCM&H/U.**

- 1) Connect all connectors.
- 2) Erase the memory.
- 3) Perform inspection mode.
- 4) Read out the trouble code.

**CHECK** : *Is the same trouble code as in the current diagnosis still being output?*

**YES** : Replace ABSCM&H/U. <Ref. to 4-4 [W14A0].>

**NO** : Go to step **10AG4**.

**10AG4 : CHECK ANY OTHER TROUBLE CODES APPEARANCE.**

**CHECK** : *Are other trouble codes being output?*

**YES** : Proceed with the diagnosis corresponding to the trouble code.

**NO** : A temporary poor contact.

**10AG5 : CHECK INPUT VOLTAGE OF G SENSOR.**

- 1) Turn ignition switch to OFF.
- 2) Remove console box.
- 3) Disconnect G sensor from body. (Do not disconnect connector.)
- 4) Turn ignition switch to ON.
- 5) Measure voltage between G sensor connector terminals.

**Connector & terminal**

**(R70) No. 1 (+) — No. 3 (-):**

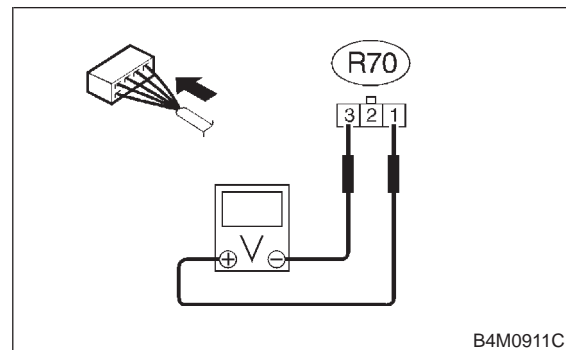

**CHECK** : *Is the voltage between 4.75 and 5.25 V?*

**YES** : Go to step **10AG6**.

**NO** : Repair harness/connector between G sensor and ABSCM&H/U.

**10AG6 : CHECK OPEN CIRCUIT IN G SENSOR OUTPUT HARNESS AND GROUND HARNESS.**

- 1) Turn ignition switch to OFF.
- 2) Disconnect connector from ABSCM&H/U.
- 3) Measure resistance between ABSCM&H/U connector terminals.

**Connector & terminal**  
(F49) No. 6 — No. 28:

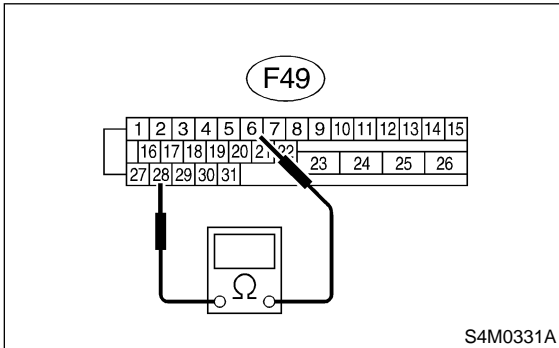

S4M0331A

- CHECK** : Is the resistance between 4.3 and 4.9 kΩ?
- YES** : Go to step 10AG7.
- NO** : Repair harness/connector between G sensor and ABSCM&H/U.

**10AG7 : CHECK GROUND SHORT IN G SENSOR OUTPUT HARNESS.**

- 1) Disconnect connector from G sensor.
- 2) Measure resistance between ABSCM&H/U connector and chassis ground.

**Connector & terminal**  
(F49) No. 6 — Chassis ground:

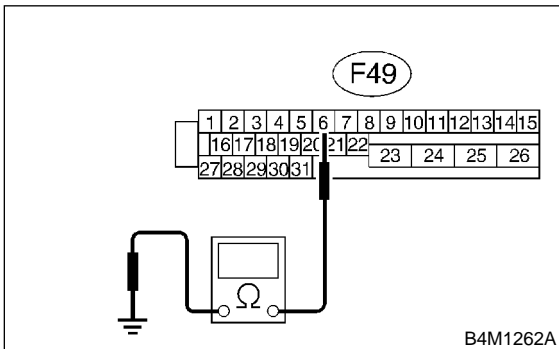

B4M1262A

- CHECK** : Is the resistance more than 1 MΩ?
- YES** : Go to step 10AG8.
- NO** : Repair harness between G sensor and ABSCM&H/U.

**10AG8 : CHECK G SENSOR.**

- 1) Connect connector to G sensor.
- 2) Connect connector to ABSCM&H/U.
- 3) Turn ignition switch to ON.
- 4) Measure voltage between G sensor connector terminals.

**Connector & terminal**  
(R70) No. 2 (+) — No. 3 (-):

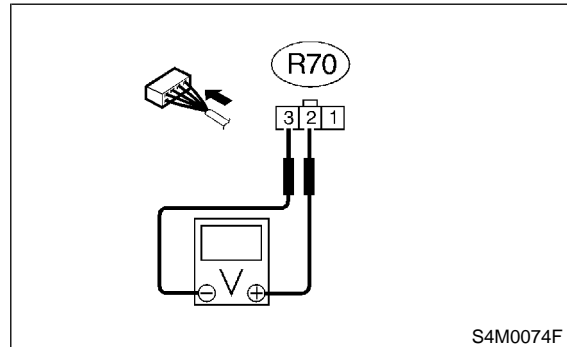

S4M0074F

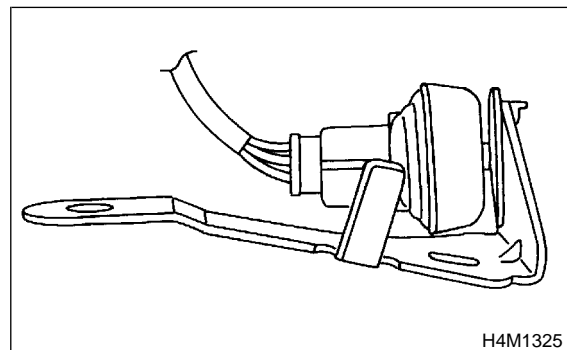

H4M1325

- CHECK** : Is the voltage between 2.1 and 2.5 V when G sensor is horizontal?
- YES** : Go to step 10AG9.
- NO** : Replace G sensor. <Ref. to 4-4 [W15A0].>



**10AG9 : CHECK G SENSOR.**

Measure voltage between G sensor connector terminals.

**Connector & terminal**

**(R70) No. 2 (+) — No. 3 (-):**

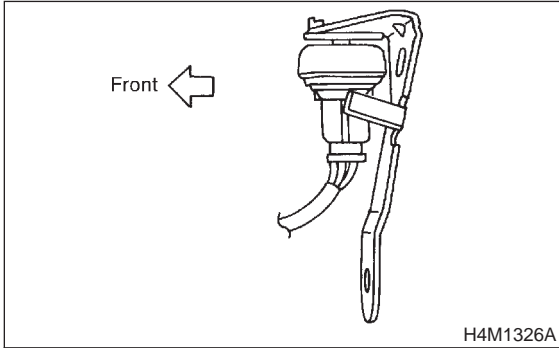

**CHECK** : *Is the voltage between 3.7 and 4.1 V when G sensor is inclined forwards to 90°?*

**YES** : Go to step 10AG10.

**NO** : Replace G sensor. <Ref. to 4-4 [W15A0].>

**10AG10 : CHECK G SENSOR.**

Measure voltage between G sensor connector terminals.

**Connector & terminal**

**(R70) No. 2 (+) — No. 3 (-):**

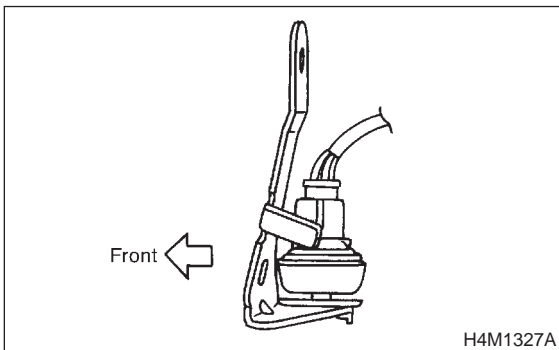

**CHECK** : *Is the voltage between 0.5 and 0.9 V when G sensor is inclined backwards to 90°?*

**YES** : Go to step 10AG11.

**NO** : Replace G sensor. <Ref. to 4-4 [W15A0].>

**10AG11 : CHECK POOR CONTACT IN CONNECTORS.**

Turn ignition switch to OFF.

**CHECK** : *Is there poor contact in connector between ABSCM&H/U and G sensor? <Ref. to FOREWORD [W3C1].>*

**YES** : Repair connector.

**NO** : Go to step 10AG12.

**10AG12 : CHECK ABSCM&H/U.**

- 1) Connect all connectors.
- 2) Erase the memory.
- 3) Perform inspection mode.
- 4) Read out the trouble code.

**CHECK** : *Is the same trouble code as in the current diagnosis still being output?*

**YES** : Replace ABSCM&H/U. <Ref. to 4-4 [W14A0].>

**NO** : Go to step 10AG13.

**10AG13 : CHECK ANY OTHER TROUBLE CODES APPEARANCE.**

**CHECK** : *Are other trouble codes being output?*

**YES** : Proceed with the diagnosis corresponding to the trouble code.

**NO** : A temporary poor contact.

**AH: TROUBLE CODE 56 BATTERY SHORT IN G SENSOR CIRCUIT — BATTERY SHORT IN G SENSOR CIRCUIT —**

**DIAGNOSIS:**

- Faulty G sensor output voltage

**TROUBLE SYMPTOM:**

- ABS does not operate.

**WIRING DIAGRAM:**

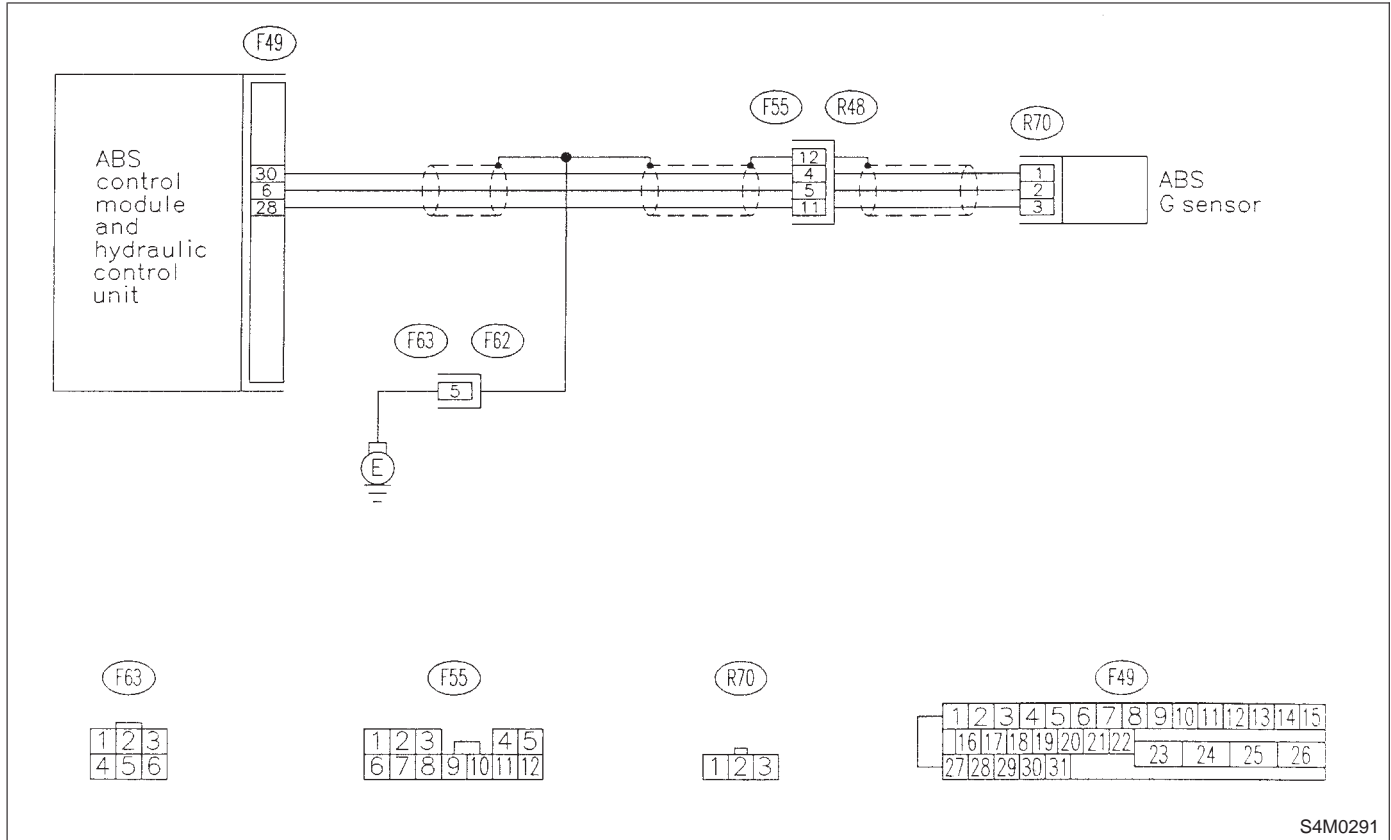

S4M0291

**10AH1 : CHECK OUTPUT OF G SENSOR USING SELECT MONITOR.**

- 1) Select "Current data display & Save" on the select monitor.
- 2) Read the G sensor output in select monitor data display.

**CHECK** : *Is the G sensor output on the monitor display between 2.1 and 2.5 V when the G sensor is in horizontal position?*

**YES** : Go to step 10AH2.

**NO** : Go to step 10AH5.

**10AH2 : CHECK POOR CONTACT IN CONNECTORS.**

**CHECK** : *Is there poor contact in connector between ABSCM&H/U and G sensor? <Ref. to FOREWORD [W3C1].>*

**YES** : Repair connector.

**NO** : Go to step 10AH3.

**10AH3 : CHECK ABSCM&H/U.**

- 1) Connect all connectors.
- 2) Erase the memory.
- 3) Perform inspection mode.
- 4) Read out the trouble code.

**CHECK** : *Is the same trouble code as in the current diagnosis still being output?*

**YES** : Replace ABSCM&H/U. <Ref. to 4-4 [W14A0].>

**NO** : Go to step 10AH4.

**10AH4 : CHECK ANY OTHER TROUBLE CODES APPEARANCE.**

**CHECK** : *Are other trouble codes being output?*

**YES** : Proceed with the diagnosis corresponding to the trouble code.

**NO** : A temporary poor contact.

**10AH5 : CHECK FREEZE FRAME DATA.**

- 1) Select "Freeze frame data" on the select monitor.
- 2) Read front right wheel speed on the select monitor display.

**CHECK** : *Is the front right wheel speed on monitor display 0 km?*

**YES** : Go to step 10AH6.

**NO** : Go to step 10AH14.

**10AH6 : CHECK FREEZE FRAME DATA.**

Read front left wheel speed on the select monitor display.

**CHECK** : *Is the front left wheel speed on monitor display 0 km?*

**YES** : Go to step 10AH7.

**NO** : Go to step 10AH14.

**10AH7 : CHECK FREEZE FRAME DATA.**

Read rear right wheel speed on the select monitor display.

**CHECK** : *Is the rear right wheel speed on monitor display 0 km?*

**YES** : Go to step 10AH8.

**NO** : Go to step 10AH14.

**10AH8 : CHECK FREEZE FRAME DATA.**

Read rear left wheel speed on the select monitor display.

**CHECK** : *Is the rear left wheel speed on monitor display 0 km?*

**YES** : Go to step 10AH9.

**NO** : Go to step 10AH14.

**10AH9 : CHECK FREEZE FRAME DATA.**

Read G sensor output on the select monitor display.

**CHECK** : *Is the G sensor output on monitor display more than 3.65 V?*

**YES** : Go to step 10AH10.

**NO** : Go to step 10AH14.

**10AH10 : CHECK OPEN CIRCUIT IN G SENSOR OUTPUT HARNESS AND GROUND HARNESS.**

- 1) Turn ignition switch to OFF.
- 2) Disconnect connector from ABSCM&H/U.
- 3) Measure resistance between ABSCM&H/U connector terminals.

**Connector & terminal**

**(F49) No. 6 — No. 28:**

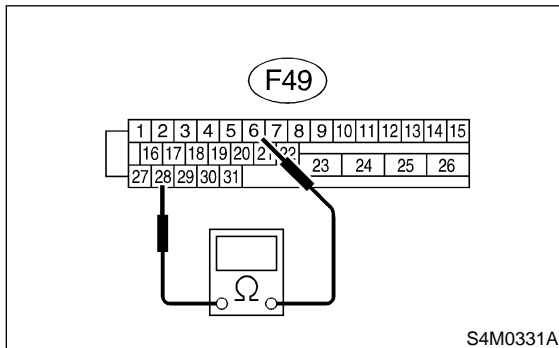

- CHECK** : *Is the resistance between 4.3 and 4.9 k $\Omega$ ?*
- YES** : Go to step **10AH11**.
- NO** : Repair harness/connector between G sensor and ABSCM&H/U.

**10AH11 : CHECK POOR CONTACT IN CONNECTORS.**

- CHECK** : *Is there poor contact in connector between ABSCM&H/U and G sensor? <Ref. to FOREWORD [W3C1].>*
- YES** : Repair connector.
- NO** : Go to step **10AH12**.

**10AH12 : CHECK ABSCM&H/U.**

- 1) Connect all connectors.
- 2) Erase the memory.
- 3) Perform inspection mode.
- 4) Read out the trouble code.

- CHECK** : *Is the same trouble code as in the current diagnosis still being output?*
- YES** : Replace ABSCM&H/U. <Ref. to 4-4 [W14A0].>
- NO** : Go to step **10AH13**.

**10AH13 : CHECK ANY OTHER TROUBLE CODES APPEARANCE.**

- CHECK** : *Are other trouble codes being output?*
- YES** : Proceed with the diagnosis corresponding to the trouble code.
- NO** : A temporary poor contact.

**10AH14 : CHECK INPUT VOLTAGE OF G SENSOR.**

- 1) Turn ignition switch to OFF.
- 2) Remove console box.
- 3) Disconnect G sensor from body. (Do not disconnect connector.)
- 4) Turn ignition switch to ON.
- 5) Measure voltage between G sensor connector terminals.

**Connector & terminal**

**(R70) No. 1 (+) — No. 3 (-):**

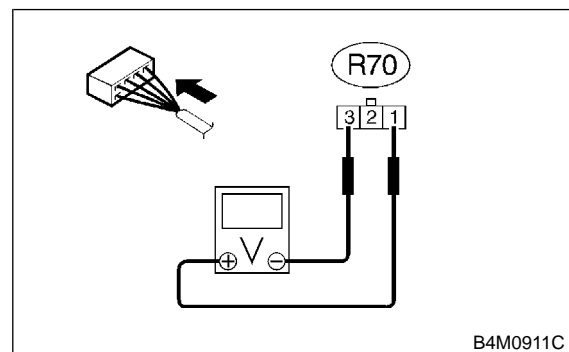

- CHECK** : *Is the voltage between 4.75 and 5.25 V?*
- YES** : Go to step **10AH15**.
- NO** : Repair harness/connector between G sensor and ABSCM&H/U.

**10AH15 : CHECK OPEN CIRCUIT IN G SENSOR OUTPUT HARNESS AND GROUND HARNESS.**

- 1) Turn ignition switch to OFF.
- 2) Disconnect connector from ABSCM&H/U.
- 3) Measure resistance between ABSCM&H/U connector terminals.

**Connector & terminal**  
**(F49) No. 6 — No. 28:**

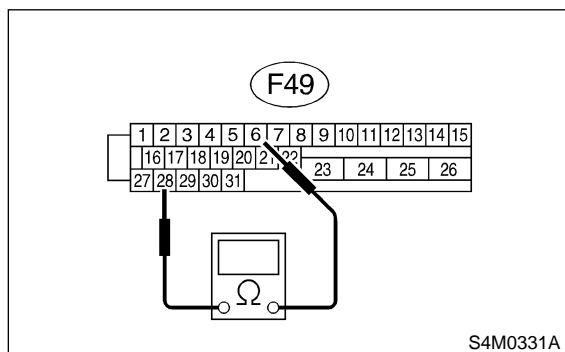

- CHECK** : *Is the resistance between 4.3 and 4.9 kΩ?*
- YES** : Go to step 10AH16.
- NO** : Repair harness/connector between G sensor and ABSCM&H/U.

**10AH16 : CHECK BATTERY SHORT OF HARNESS.**

- 1) Turn ignition switch to OFF.
- 2) Remove console box.
- 3) Disconnect connector from G sensor.
- 4) Disconnect connector from ABSCM&H/U.
- 5) Measure voltage between ABSCM&H/U connector and chassis ground.

**Connector & terminal**  
**(F49) No. 6 (+) — Chassis ground (-):**

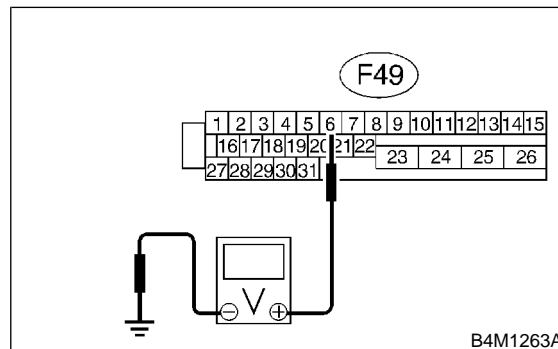

- CHECK** : *Is the voltage less than 1 V?*
- YES** : Go to step 10AH17.
- NO** : Repair harness between G sensor and ABSCM&H/U.

**10AH17 : CHECK BATTERY SHORT OF HARNESS.**

- 1) Turn ignition switch to ON.
- 2) Measure voltage between ABSCM&H/U connector and chassis ground.

**Connector & terminal**  
**(F49) No. 6 (+) — Chassis ground (-):**

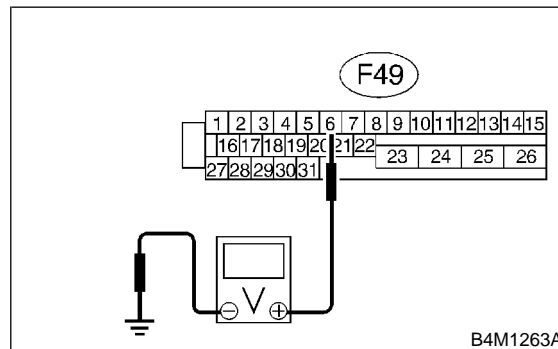

- CHECK** : *Is the voltage less than 1 V?*
- YES** : Go to step 10AH18.
- NO** : Repair harness between G sensor and ABSCM&H/U.

**10AH18 : CHECK G SENSOR.**

- 1) Connect connector to G sensor.
- 2) Connect connector to ABSCM&H/U.
- 3) Turn ignition switch to ON.
- 4) Measure voltage between G sensor connector terminals.

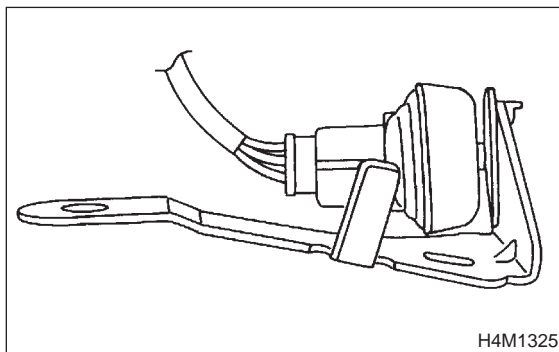
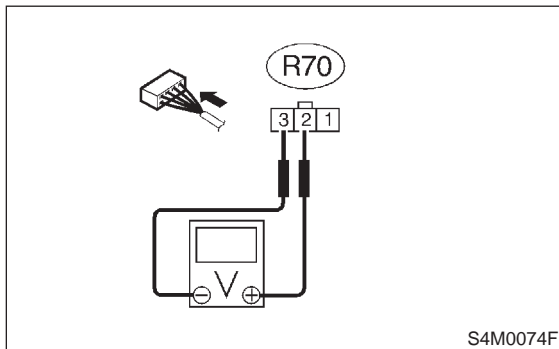
**Connector & terminal****(R70) No. 2 (+) — No. 3 (-):**

- CHECK** : *Is the voltage between 2.1 and 2.5 V when G sensor is horizontal?*
- YES** : Go to step **10AH19**.
- NO** : Replace G sensor. <Ref. to 4-4 [W15A0].>

**10AH19 : CHECK G SENSOR.**

Measure voltage between G sensor connector terminals.

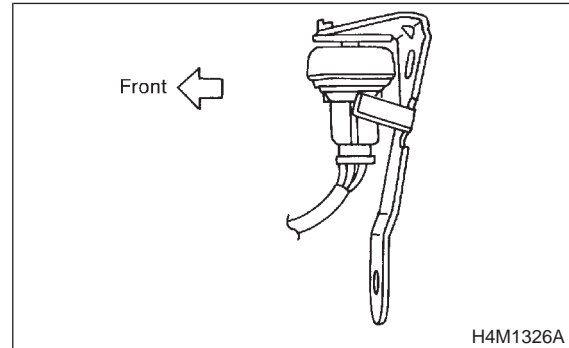
**Connector & terminal****(R70) No. 2 (+) — No. 3 (-):**

- CHECK** : *Is the voltage between 3.7 and 4.1 V when G sensor is inclined forwards to 90°?*

- YES** : Go to step **10AH20**.
- NO** : Replace G sensor. <Ref. to 4-4 [W15A0].>

**10AH20 : CHECK G SENSOR.**

Measure voltage between G sensor connector terminals.

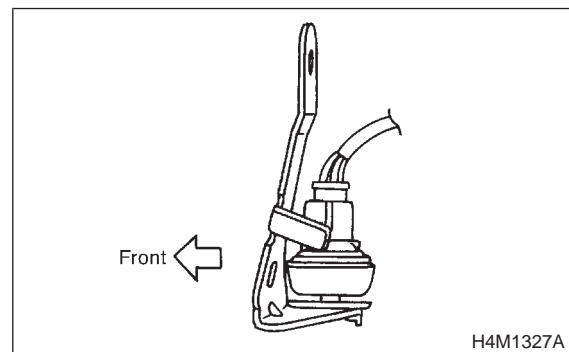
**Connector & terminal****(R70) No. 2 (+) — No. 3 (-):**

- CHECK** : *Is the voltage between 0.5 and 0.9 V when G sensor is inclined backwards to 90°?*

- YES** : Go to step **10AH21**.
- NO** : Replace G sensor. <Ref. to 4-4 [W15A0].>

**10AH21 : CHECK POOR CONTACT IN CONNECTORS.**

Turn ignition switch to OFF.

**CHECK** : *Is there poor contact in connector between ABSCM&H/U and G sensor? <Ref. to FOREWORD [W3C1].>*

**YES** : Repair connector.

**NO** : Go to step **10AH22**.

**10AH22 : CHECK ABSCM&H/U.**

- 1) Connect all connectors.
- 2) Erase the memory.
- 3) Perform inspection mode.
- 4) Read out the trouble code.

**CHECK** : *Is the same trouble code as in the current diagnosis still being output?*

**YES** : Replace ABSCM&H/U. <Ref. to 4-4 [W14A0].>

**NO** : Go to step **10AH23**.

**10AH23 : CHECK ANY OTHER TROUBLE CODES APPEARANCE.**

**CHECK** : *Are other trouble codes being output?*

**YES** : Proceed with the diagnosis corresponding to the trouble code.

**NO** : A temporary poor contact.

**AI: TROUBLE CODE 56 ABNORMAL G SENSOR HIGH  $\mu$  OUTPUT — ABNORMAL G SENSOR HIGH  $\mu$  OUTPUT —**

**DIAGNOSIS:**

- Faulty G sensor output voltage

**TROUBLE SYMPTOM:**

- ABS does not operate.

**WIRING DIAGRAM:**

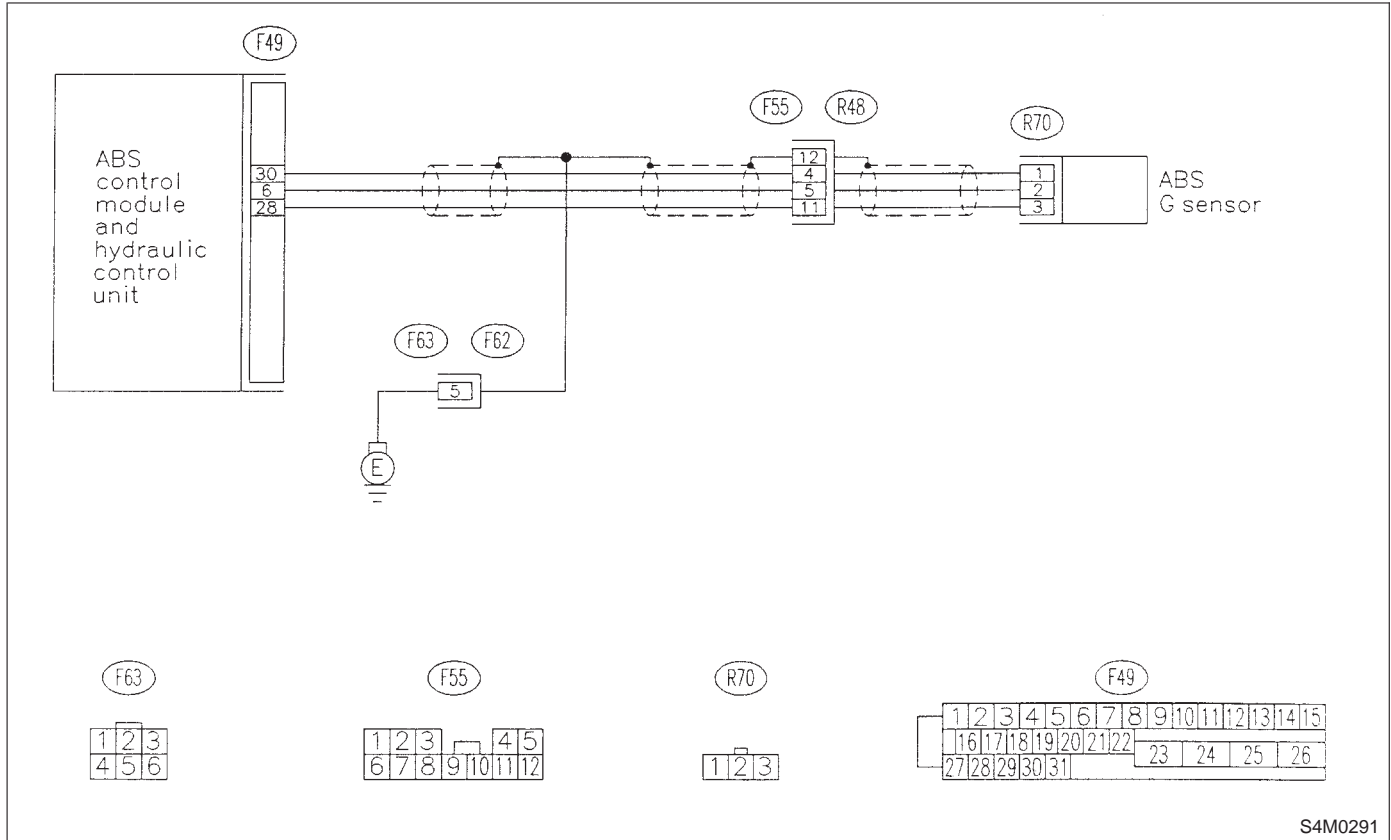

S4M0291



**10A11 : CHECK OUTPUT OF G SENSOR USING SELECT MONITOR.**

- 1) Select "Current data display & Save" on the select monitor.
- 2) Read G sensor output on the select monitor display.

**CHECK** : *Is the G sensor output on monitor display between 2.1 and 2.5 V when the G sensor is in horizontal position?*

**YES** : Go to step 10A12.

**NO** : Go to step 10A15.

**10A12 : CHECK POOR CONTACT IN CONNECTORS.**

Turn ignition switch to OFF.

**CHECK** : *Is there poor contact in connector between ABSCM&H/U and G sensor? <Ref. to FOREWORD [W3C1].>*

**YES** : Repair connector.

**NO** : Go to step 10A13.

**10A13 : CHECK ABSCM&H/U.**

- 1) Connect all connectors.
- 2) Erase the memory.
- 3) Perform inspection mode.
- 4) Read out the trouble code.

**CHECK** : *Is the same trouble code as in the current diagnosis still being output?*

**YES** : Replace ABSCM&H/U. <Ref. to 4-4 [W14A0].>

**NO** : Go to step 10A14.

**10A14 : CHECK ANY OTHER TROUBLE CODES APPEARANCE.**

**CHECK** : *Are other trouble codes being output?*

**YES** : Proceed with the diagnosis corresponding to the trouble code.

**NO** : A temporary poor contact.

**10A15 : CHECK OPEN CIRCUIT IN G SENSOR OUTPUT HARNESS AND GROUND HARNESS.**

- 1) Turn ignition switch to OFF.
- 2) Disconnect connector from ABSCM&H/U.
- 3) Measure resistance between ABSCM&H/U connector terminals.

**Connector & terminal**  
**(F49) No. 6 — No. 28:**

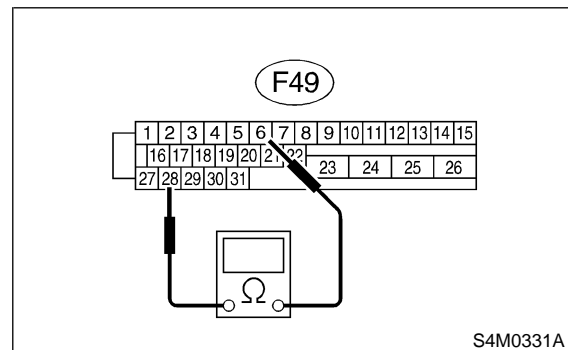

**CHECK** : *Is the resistance between 4.3 and 4.9 kΩ?*

**YES** : Go to step 10A16.

**NO** : Repair harness/connector between G sensor and ABSCM&H/U.

**10A16 : CHECK GROUND SHORT OF HARNESS.**

Measure resistance between ABSCM&H/U connector and chassis ground.

**Connector & terminal**  
**(F49) No. 28 — Chassis ground:**

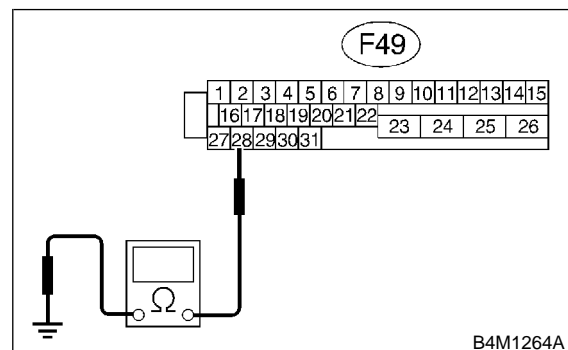

**CHECK** : *Is the resistance more than 1 MΩ?*

**YES** : Go to step 10A17.

**NO** : Repair harness between G sensor and ABSCM&H/U.

**10A17 : CHECK G SENSOR.**

- 1) Remove console box.
- 2) Remove G sensor from vehicle.
- 3) Connect connector to G sensor.
- 4) Connect connector to ABSCM&H/U.
- 5) Turn ignition switch to ON.
- 6) Measure voltage between G sensor connector terminals.

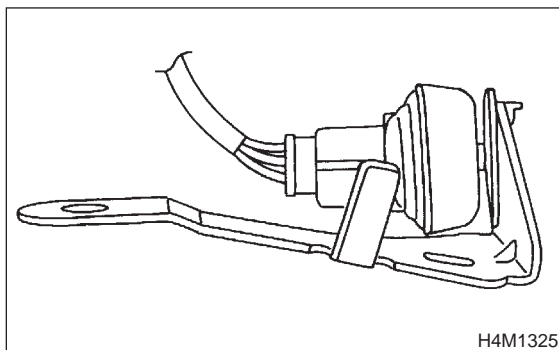
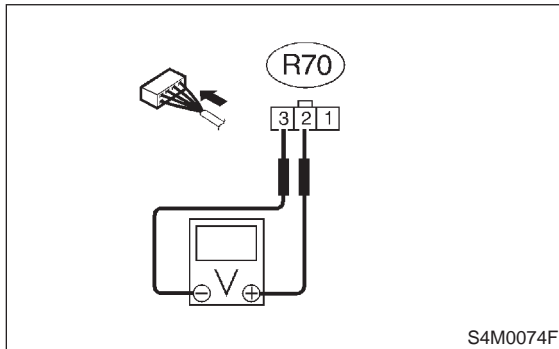
**Connector & terminal****(R70) No. 2 (+) — No. 3 (-):**

- CHECK** : *Is the voltage between 2.1 and 2.5 V when G sensor is horizontal?*
- YES** : Go to step **10A18**.
- NO** : Replace G sensor. <Ref. to 4-4 [W15A0].>

**10A18 : CHECK G SENSOR.**

Measure voltage between G sensor connector terminals.

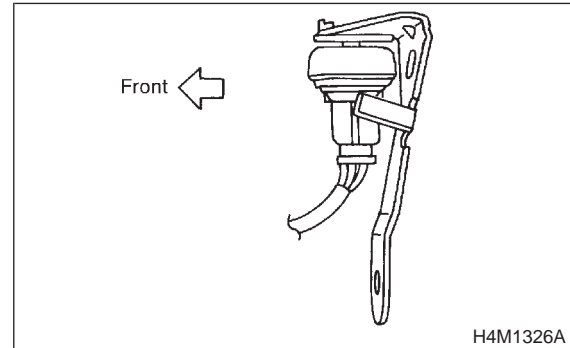
**Connector & terminal****(R70) No. 2 (+) — No. 3 (-):**

**CHECK** : *Is the voltage between 3.7 and 4.1 V when G sensor is inclined forwards to 90°?*

- YES** : Go to step **10A19**.
- NO** : Replace G sensor. <Ref. to 4-4 [W15A0].>

**10A19 : CHECK G SENSOR.**

Measure voltage between G sensor connector terminals.

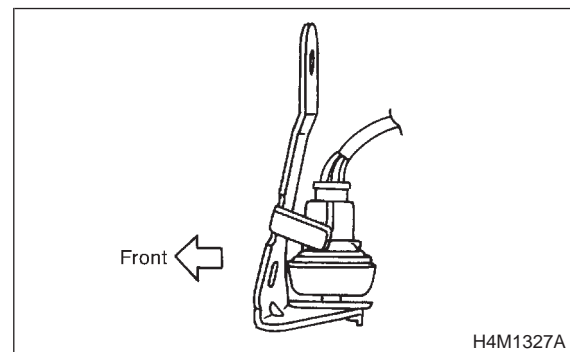
**Connector & terminal****(R70) No. 2 (+) — No. 3 (-):**

**CHECK** : *Is the voltage between 0.5 and 0.9 V when G sensor is inclined backwards to 90°?*

- YES** : Go to step **10A10**.
- NO** : Replace G sensor. <Ref. to 4-4 [W15A0].>

**10AI10 : CHECK ABSCM&H/U.**

- 1) Turn ignition switch to OFF.
- 2) Connect all connectors.
- 3) Erase the memory.
- 4) Perform inspection mode.
- 5) Read out the trouble code.

**CHECK** : *Is the same trouble code as in the current diagnosis still being output?*

**YES** : Replace ABSCM&H/U. <Ref. to 4-4 [W14A0].>

**NO** : Go to step **10AI11**.

**10AI11 : CHECK ANY OTHER TROUBLE CODES APPEARANCE.**

**CHECK** : *Are other trouble codes being output?*

**YES** : Proceed with the diagnosis corresponding to the trouble code.

**NO** : A temporary poor contact.

**AJ: TROUBLE CODE 56 DETECTION OF G SENSOR STICK  
— DETECTION OF G SENSOR STICK —**

**DIAGNOSIS:**

- Faulty G sensor output voltage

**TROUBLE SYMPTOM:**

- ABS does not operate.

**WIRING DIAGRAM:**

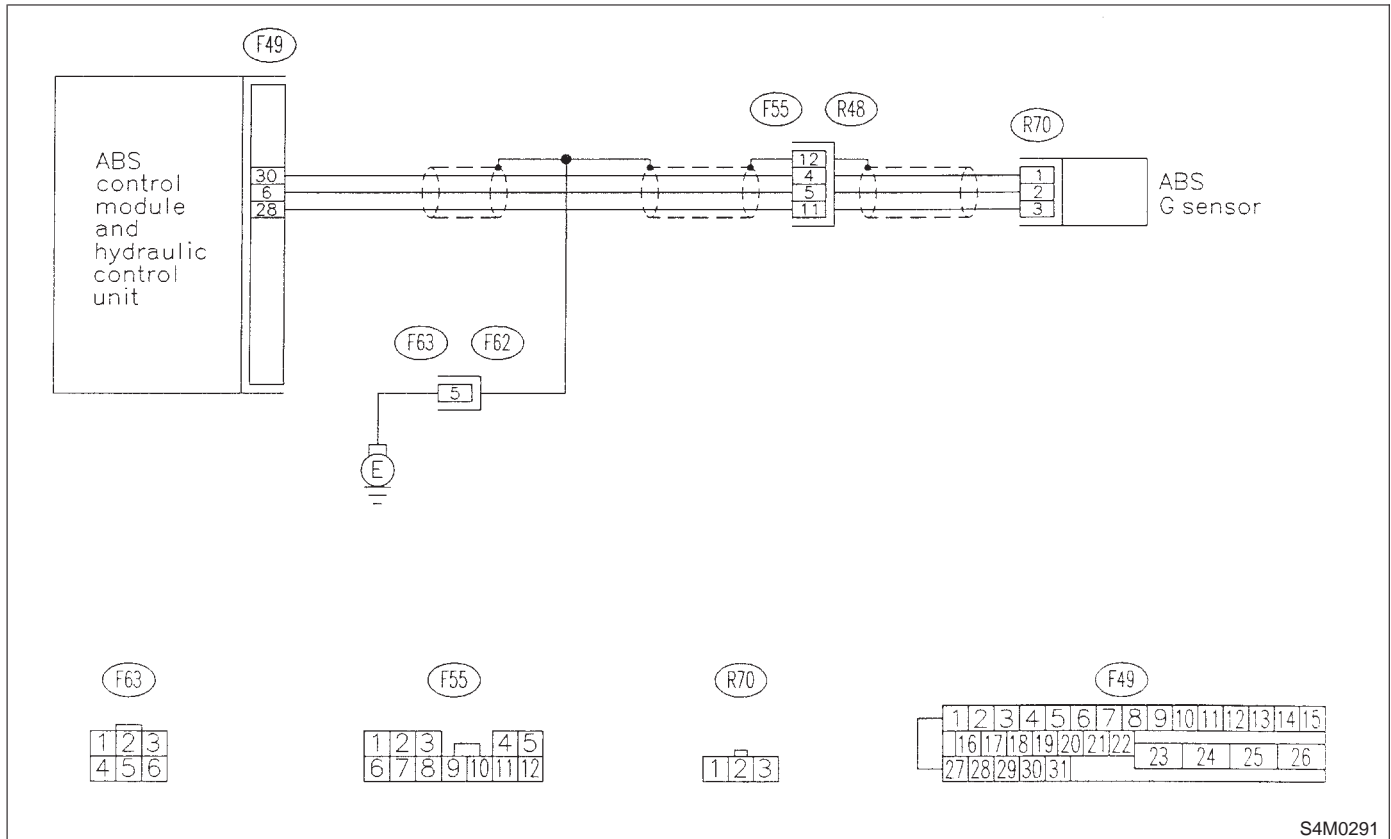

S4M0291

**10AJ1 : CHECK ALL FOUR WHEELS FOR FREE TURNING.**

**CHECK** : *Have the wheels been turned freely such as when the vehicle is lifted up, or operated on a rolling road?*

**YES** : The ABS is normal. Erase the trouble code.

**NO** : Go to step **10AJ2**.

**10AJ2 : CHECK OUTPUT OF G SENSOR USING SELECT MONITOR.**

1) Select "Current data display & Save" on the select monitor.

2) Read the select monitor display.

**CHECK** : *Is the G sensor output on the monitor display between 2.1 and 2.5 V when the vehicle is in horizontal position?*

**YES** : Go to step **10AJ3**.

**NO** : Go to step **10AJ8**.

**10AJ3 : CHECK OUTPUT OF G SENSOR USING SELECT MONITOR.**

1) Turn ignition switch to OFF.

2) Remove console box.

3) Remove G sensor from vehicle. (Do not disconnect connector.)

4) Turn ignition switch to ON.

5) Select "Current data display & Save" on the select monitor.

6) Read the select monitor display.

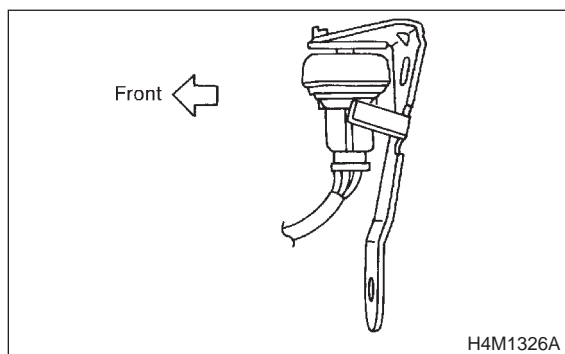

**CHECK** : *Is the G sensor output on the monitor display between 3.7 and 4.1 V when G sensor is inclined forwards to 90°?*

**YES** : Go to step **10AJ4**.

**NO** : Replace G sensor. <Ref. to 4-4 [W15A0].>

**10AJ4 : CHECK OUTPUT OF G SENSOR USING SELECT MONITOR.**

Read the select monitor display.

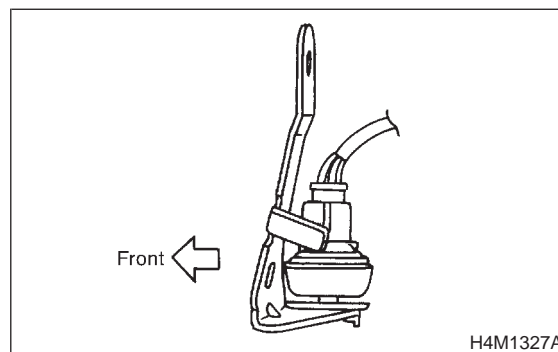

**CHECK** : *Is the G sensor output on the monitor display between 0.5 and 0.9 V when G sensor is inclined backwards to 90°?*

**YES** : Go to step **10AJ5**.

**NO** : Replace G sensor. <Ref. to 4-4 [W15A0].>

**10AJ5 : CHECK POOR CONTACT IN CONNECTORS.**

Turn ignition switch to OFF.

**CHECK** : *Is there poor contact in connector between ABSCM&H/U and G sensor? <Ref. to FOREWORD [W3C1].>*

**YES** : Repair connector.

**NO** : Go to step **10AJ6**.

**10AJ6 : CHECK ABSCM&H/U.**

1) Connect all connectors.

2) Erase the memory.

3) Perform inspection mode.

4) Read out the trouble code.

**CHECK** : *Is the same trouble code as in the current diagnosis still being output?*

**YES** : Replace ABSCM&H/U. <Ref. to 4-4 [W14A0].>

**NO** : Go to step **10AJ7**.

**10AJ7 : CHECK ANY OTHER TROUBLE CODES APPEARANCE.**

- CHECK** : Are other trouble codes being output?
- YES** : Proceed with the diagnosis corresponding to the trouble code.
- NO** : A temporary poor contact.

**10AJ8 : CHECK OPEN CIRCUIT IN G SENSOR OUTPUT HARNESS AND GROUND HARNESS.**

- 1) Turn ignition switch to OFF.
- 2) Disconnect connector from ABSCM&H/U.
- 3) Measure resistance between ABSCM&H/U connector terminals.

**Connector & terminal**  
**(F49) No. 6 — No. 28:**

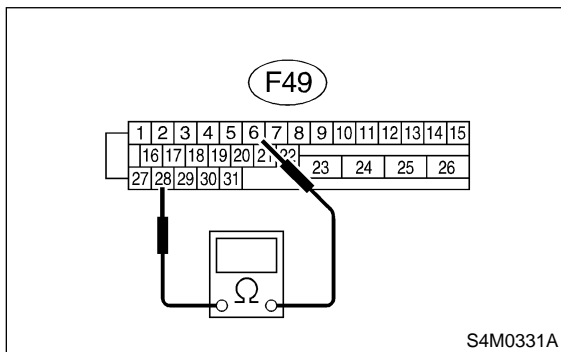

- CHECK** : Is the resistance between 4.3 and 4.9 kΩ?
- YES** : Go to step 10AJ9.
- NO** : Repair harness/connector between G sensor and ABSCM&H/U.

**10AJ9 : CHECK G SENSOR.**

- 1) Remove console box.
- 2) Remove G sensor from vehicle.
- 3) Connect connector to G sensor.
- 4) Connect connector to ABSCM&H/U.
- 5) Turn ignition switch to ON.
- 6) Measure voltage between G sensor connector terminals.

**Connector & terminal**  
**(R70) No. 2 (+) — No. 1 (-):**

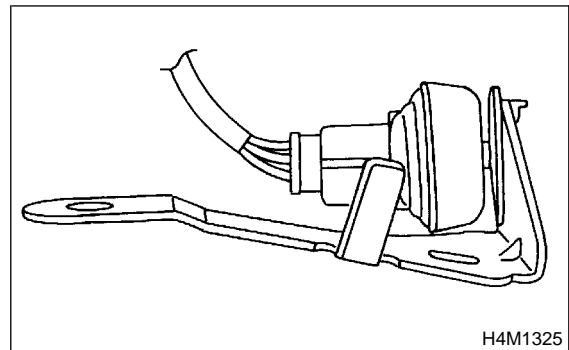
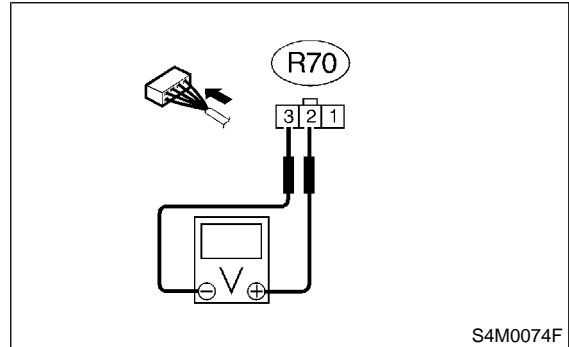

- CHECK** : Is the voltage between 2.1 and 2.5 V when G sensor is horizontal?
- YES** : Go to step 10AJ10.
- NO** : Replace G sensor. <Ref. to 4-4 [W15A0].>

**10AJ10 : CHECK G SENSOR.**

Measure voltage between G sensor connector terminals.

**Connector & terminal**

**(R70) No. 2 (+) — No. 1 (-):**

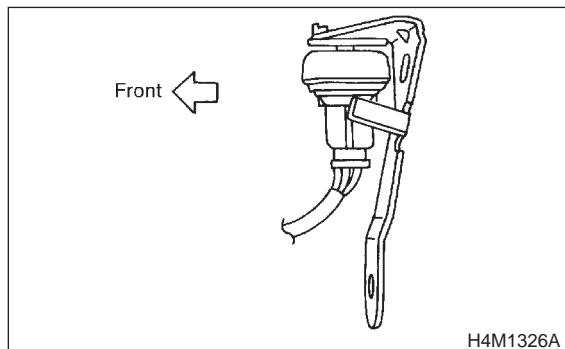

**CHECK** : *Is the voltage between 3.7 and 4.1 V when G sensor is inclined forwards to 90°?*

**YES** : Go to step 10AJ11.

**NO** : Replace G sensor. <Ref. to 4-4 [W15A0].>

**10AJ11 : CHECK G SENSOR.**

Measure voltage between G sensor connector terminals.

**Connector & terminal**

**(R70) No. 2 (+) — No. 1 (-):**

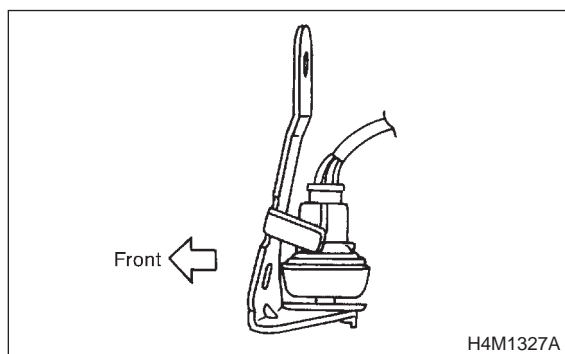

**CHECK** : *Is the voltage between 0.5 and 0.9 V when G sensor is inclined backwards to 90°?*

**YES** : Go to step 10AJ12.

**NO** : Replace G sensor. <Ref. to 4-4 [W15A0].>

**10AJ12 : CHECK ABSCM&H/U.**

- 1) Turn ignition switch to OFF.
- 2) Connect all connectors.
- 3) Erase the memory.
- 4) Perform inspection mode.
- 5) Read out the trouble code.

**CHECK** : *Is the same trouble code as in the current diagnosis still being output?*

**YES** : Replace ABSCM&H/U. <Ref. to 4-4 [W14A0].>

**NO** : Go to step 10AJ13.

**10AJ13 : CHECK ANY OTHER TROUBLE CODES APPEARANCE.**

**CHECK** : *Are other trouble codes being output?*

**YES** : Proceed with the diagnosis corresponding to the trouble code.

**NO** : A temporary poor contact.

## 11. General Diagnostics Table

### A: SYMPTOMS AND PROBABLE CAUSES

Symptom		Probable faulty units/parts
Vehicle instability during braking	Vehicle pulls to either side.	<ul style="list-style-type: none"> <li>● ABSCM&amp;H/U (solenoid valve)</li> <li>● ABS sensor</li> <li>● Brake (caliper &amp; piston, pads)</li> <li>● Wheel alignment</li> <li>● Tire specifications, tire wear and air pressures</li> <li>● Incorrect wiring or piping connections</li> <li>● Road surface (uneven, camber)</li> </ul>
	Vehicle spins.	<ul style="list-style-type: none"> <li>● ABSCM&amp;H/U (solenoid valve)</li> <li>● ABS sensor</li> <li>● Brake (pads)</li> <li>● Tire specifications, tire wear and air pressures</li> <li>● Incorrect wiring or piping connections</li> </ul>
Poor braking	Long braking/stopping distance	<ul style="list-style-type: none"> <li>● ABSCM&amp;H/U (solenoid valve)</li> <li>● Brake (pads)</li> <li>● Air in brake line</li> <li>● Tire specifications, tire wear and air pressures</li> <li>● Incorrect wiring or piping connections</li> </ul>
	Wheel locks.	<ul style="list-style-type: none"> <li>● ABSCM&amp;H/U (solenoid valve, motor)</li> <li>● ABS sensor</li> <li>● Incorrect wiring or piping connections</li> </ul>
	Brake dragging	<ul style="list-style-type: none"> <li>● ABSCM&amp;H/U (solenoid valve)</li> <li>● ABS sensor</li> <li>● Master cylinder</li> <li>● Brake (caliper &amp; piston)</li> <li>● Parking brake</li> <li>● Axle &amp; wheels</li> <li>● Brake pedal play</li> </ul>
	Long brake pedal stroke	<ul style="list-style-type: none"> <li>● Air in brake line</li> <li>● Brake pedal play</li> </ul>
	Vehicle pitching	<ul style="list-style-type: none"> <li>● Suspension play or fatigue (reduced damping)</li> <li>● Incorrect wiring or piping connections</li> <li>● Road surface (uneven)</li> </ul>
	Unstable or uneven braking	<ul style="list-style-type: none"> <li>● ABSCM&amp;H/U (solenoid valve)</li> <li>● ABS sensor</li> <li>● Brake (caliper &amp; piston, pads)</li> <li>● Tire specifications, tire wear and air pressures</li> <li>● Incorrect wiring or piping connections</li> <li>● Road surface (uneven)</li> </ul>
Vibration and/or noise (while driving on slippery roads)	Excessive pedal vibration	<ul style="list-style-type: none"> <li>● Incorrect wiring or piping connections</li> <li>● Road surface (uneven)</li> </ul>
	Noise from ABSCM&H/U	<ul style="list-style-type: none"> <li>● ABSCM&amp;H/U (mount bushing)</li> <li>● ABS sensor</li> <li>● Brake piping</li> </ul>
	Noise from front of vehicle	<ul style="list-style-type: none"> <li>● ABSCM &amp; H/U (mount bushing)</li> <li>● ABS sensor</li> <li>● Master cylinder</li> <li>● Brake (caliper &amp; piston, pads, rotor)</li> <li>● Brake piping</li> <li>● Brake booster &amp; check valve</li> <li>● Suspension play or fatigue</li> </ul>
	Noise from rear of vehicle	<ul style="list-style-type: none"> <li>● ABS sensor</li> <li>● Brake (caliper &amp; piston, pads, rotor)</li> <li>● Parking brake</li> <li>● Brake piping</li> <li>● Suspension play or fatigue</li> </ul>



**B: CHECKING THE HYDRAULIC  
UNIT OPERATION****11B1 : PREPARING THE BRAKE TESTER.**

- CHECK** : *Is the brake tester available?*
- YES** : CHECKING THE HYDRAULIC UNIT  
ABS OPERATION WITH BRAKE  
TESTER <Ref. to 4-4 [W14C2].>
- NO** : CHECKING THE HYDRAULIC UNIT  
ABS OPERATION BY PRESSURE  
GAUGE <Ref. to 4-4 [W14C1].>

MEMO:

## 1. Stabilizer

Model	Bar dia.	
	Front	Rear
2500 cc	19 mm (0.75 in)	13 mm (0.51 in)

## 2. Wheel Alignment

Front	Camber (tolerance: $\pm 0^{\circ}30'$ )	$-0^{\circ}15'$
	Caster (tolerance: $\pm 0^{\circ}45'$ )	$2^{\circ}35'$
	Toe-in	$0 \pm 3$ mm ( $0 \pm 0.12$ in) Each toe angle: $0^{\circ} \pm 09'$
	Kingpin angle (tolerance: $\pm 1^{\circ}$ )	$13^{\circ}25'$
	Wheel arch height [tolerance: $+12/-24$ mm ( $+0.47/-0.94$ in)]	432 mm (17.01 in)
Rear	Camber (tolerance: $\pm 0^{\circ}45'$ )	$-0^{\circ}35'$
	Toe-in	1 — 4 mm (0.04 — 0.16 in) Each toe angle: $0^{\circ}03' — 0^{\circ}12'$
	Wheel arch height [tolerance: $+12/-24$ mm ( $+0.47/-0.94$ in)]	435 mm (17.13 in)
	Thrust angle	$0^{\circ} \pm 20'$

**NOTE:**

- Front and rear toe-ins and front camber can be adjusted. If toe-in or front camber tolerance exceeds specifications, adjust toe-in and camber to the specification.
- The other items indicated in the specification table cannot be adjusted. If the other items exceeds specifications, check suspension parts and joint portions of body suspension parts for deformities; and replace with new ones as required.

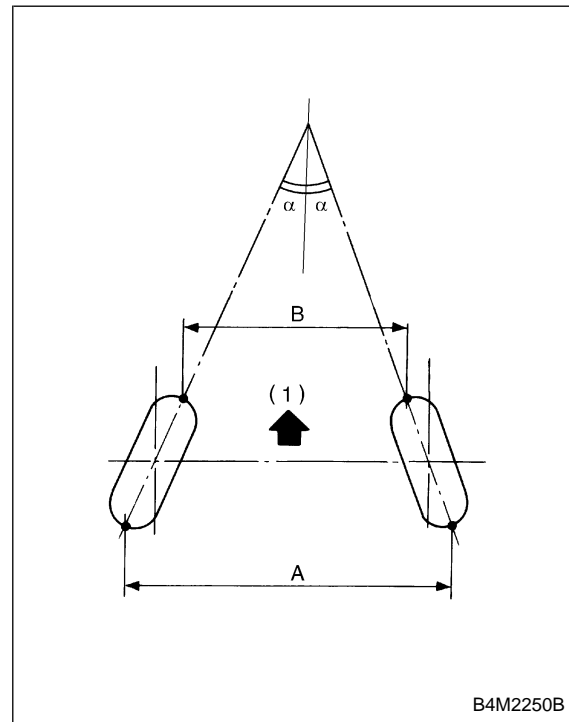

- (1) Front  
 A – B = Positive: Toe-in, Negative: Toe-out  
 $\alpha$  = Each toe angle

## 1. Stabilizer

Model	Bar dia.	
	Front	Rear
2500 cc	19 mm (0.75 in)	13 mm (0.51 in)

## 2. Wheel Alignment

Front	Camber (tolerance: $\pm 0^{\circ}30'$ )	$-0^{\circ}15'$
	Caster (tolerance: $\pm 0^{\circ}45'$ )	$2^{\circ}35'$
	Toe-in	$0 \pm 3$ mm ( $0 \pm 0.12$ in) Each toe angle: $0^{\circ} \pm 09'$
	Kingpin angle (tolerance: $\pm 1^{\circ}$ )	$13^{\circ}25'$
	Wheel arch height [tolerance: $+12/-24$ mm ( $+0.47/-0.94$ in)]	432 mm (17.01 in)
Rear	Camber (tolerance: $\pm 0^{\circ}45'$ )	$-0^{\circ}35'$
	Toe-in	1 — 4 mm (0.04 — 0.16 in) Each toe angle: $0^{\circ}03' — 0^{\circ}12'$
	Wheel arch height [tolerance: $+12/-24$ mm ( $+0.47/-0.94$ in)]	435 mm (17.13 in)
	Thrust angle	$0^{\circ} \pm 20'$

**NOTE:**

- Front and rear toe-ins and front camber can be adjusted. If toe-in or front camber tolerance exceeds specifications, adjust toe-in and camber to the specification.
- The other items indicated in the specification table cannot be adjusted. If the other items exceeds specifications, check suspension parts and joint portions of body suspension parts for deformities; and replace with new ones as required.

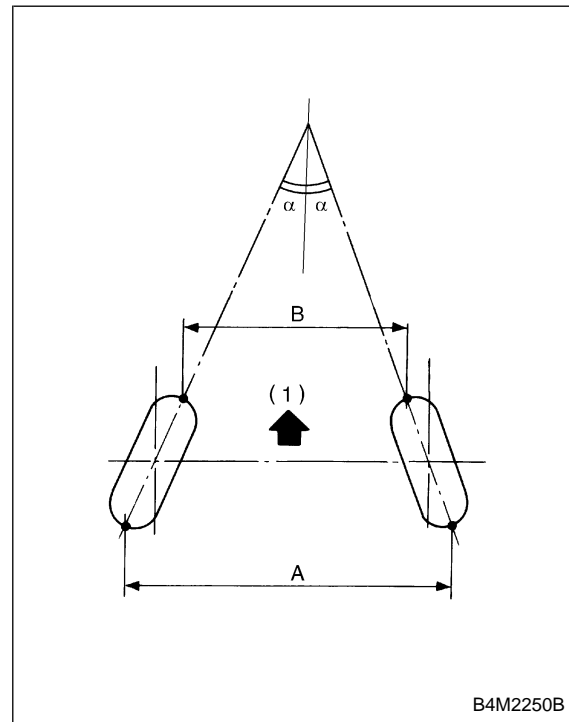

- (1) Front  
 A - B = Positive: Toe-in, Negative: Toe-out  
 $\alpha$  = Each toe angle

1. Front Suspension

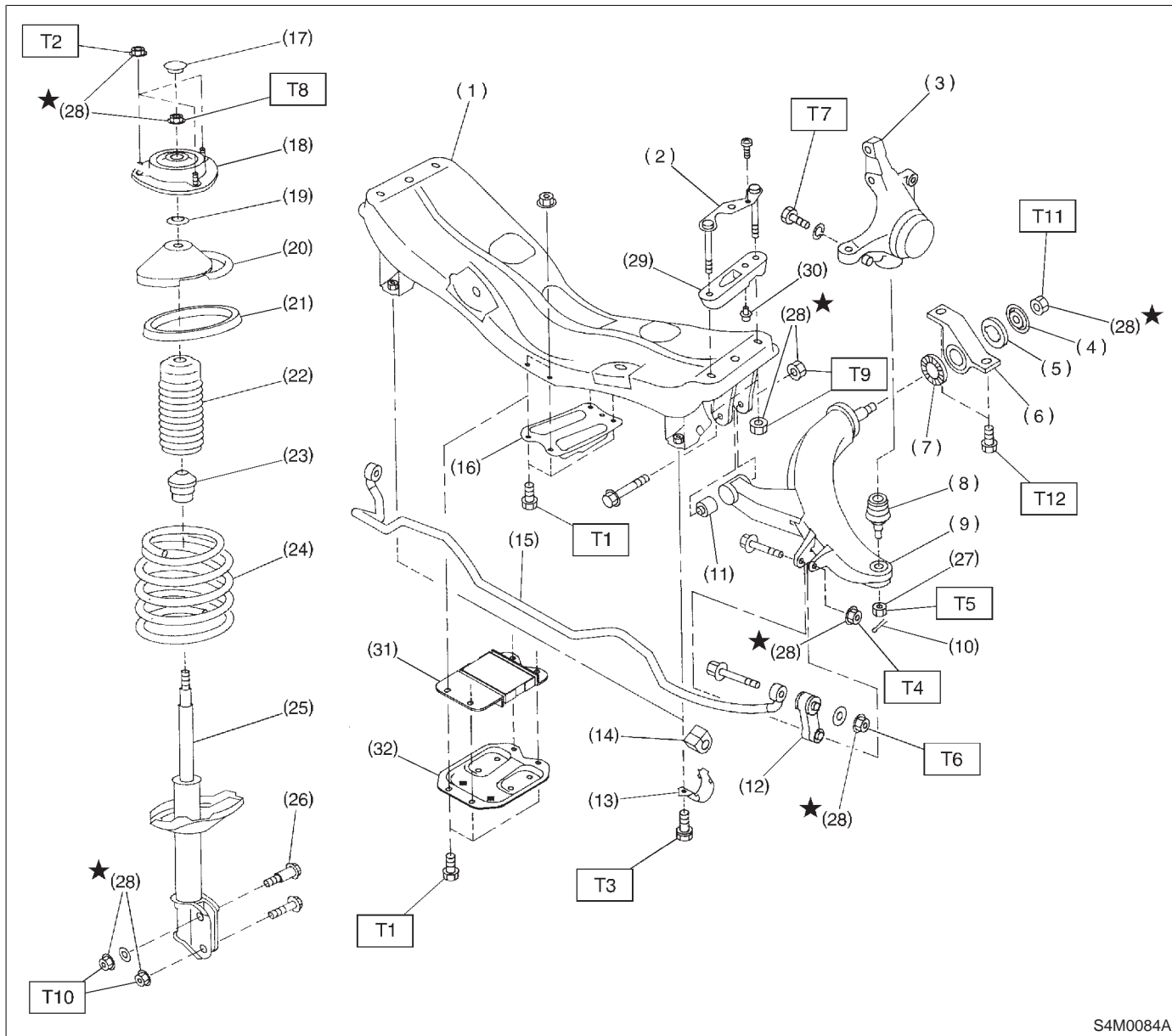

S4M0084A

- |                                      |                                |
|--------------------------------------|--------------------------------|
| (1) Front crossmember                | (17) Dust seal                 |
| (2) Bolt ASSY                        | (18) Strut mount               |
| (3) Housing                          | (19) Spacer                    |
| (4) Washer                           | (20) Upper spring seat         |
| (5) Stopper rubber (Rear)            | (21) Rubber seat               |
| (6) Rear bushing                     | (22) Dust cover                |
| (7) Stopper rubber (Front)           | (23) Helper                    |
| (8) Ball joint                       | (24) Coil spring               |
| (9) Transverse link                  | (25) Damper strut              |
| (10) Cotter pin                      | (26) Adjusting bolt            |
| (11) Front bushing                   | (27) Castle nut                |
| (12) Stabilizer link                 | (28) Self-locking nut          |
| (13) Clamp                           | (29) Adapter front crossmember |
| (14) Bushing                         | (30) Clip                      |
| (15) Stabilizer                      | (31) Dynamic damper (MT model) |
| (16) Jack-up plate (Except MT model) | (32) Jack-up plate (MT model)  |

**Tightening torque: N·m (kg·m, ft·lb)**

- T1: 18±5 (1.8±0.5, 13.0±3.6)**  
**T2: 20±6 (2.0±0.6, 14.5±4.3)**  
**T3: 25±4 (2.5±0.4, 18.1±2.9)**  
**T4: 29±5 (3.0±0.5, 21.7±3.6)**  
**T5: 39 (4, 29)**  
**T6: 44±6 (4.5±0.6, 32.5±4.3)**  
**T7: 49±10 (5.0±1.0, 36±7)**  
**T8: 54±5 (5.5±0.5, 39.8±3.6)**  
**T9: 98±15 (10.0±1.5, 72±11)**  
**T10: 152±20 (15.5±2.0, 112±14)**  
**T11: 186±10 (19.0±1.0, 137±7)**  
**T12: 245±49 (25.0±5.0, 181±36)**

2. Rear Suspension

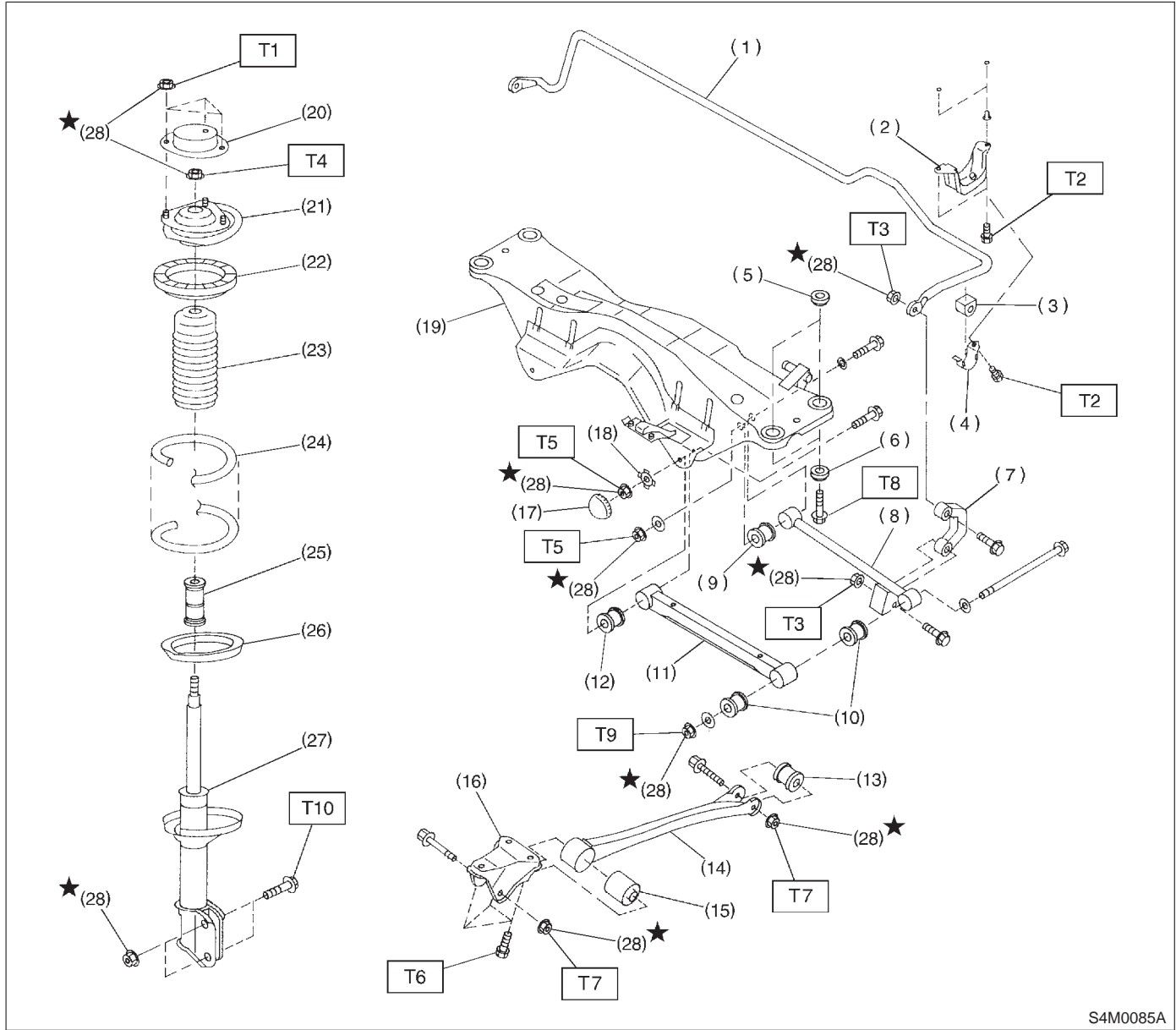

S4M0085A

- (1) Stabilizer
- (2) Stabilizer bracket
- (3) Stabilizer bushing
- (4) Clamp
- (5) Floating bushing
- (6) Stopper
- (7) Stabilizer link
- (8) Rear lateral link
- (9) Bushing (C)
- (10) Bushing (A)
- (11) Front lateral link
- (12) Bushing (B)
- (13) Trailing link rear bushing
- (14) Trailing link
- (15) Trailing link front bushing
- (16) Trailing link bracket
- (17) Cap (Protection)
- (18) Washer
- (19) Rear crossmember
- (20) Strut mount cap
- (21) Strut mount
- (22) Rubber seat upper
- (23) Dust cover
- (24) Coil spring
- (25) Helper
- (26) Rubber seat lower
- (27) Damper strut
- (28) Self-locking nut

**Tightening torque: N·m (kg·m, ft·lb)**

- T1: 20±6 (2.0±0.6, 14.5±4.3)**
- T2: 25±7 (2.5±0.7, 18.1±5.1)**
- T3: 44±6 (4.5±0.6, 32.5±4.3)**
- T4: 59±10 (6.0±1.0, 43±7)**
- T5: 98±15 (10.0±1.5, 72±11)**
- T6: 98±20 (10.0±2.0, 72±14)**
- T7: 113±15 (11.5±1.5, 83±11)**
- T8: 127±20 (13.0±2.0, 94±14)**
- T9: 137±20 (14.0±2.0, 101±14)**
- T10: 196<sup>+39</sup>/<sub>-10</sub> (20.0<sup>+4.0</sup>/<sub>-1.0</sub>, 145<sup>+29</sup>/<sub>-7</sub>)**

## 1. On-car Services

### A: WHEEL ALIGNMENT PROCEDURES

Check, adjust and/or measure wheel alignment in accordance with procedures indicated in figure:

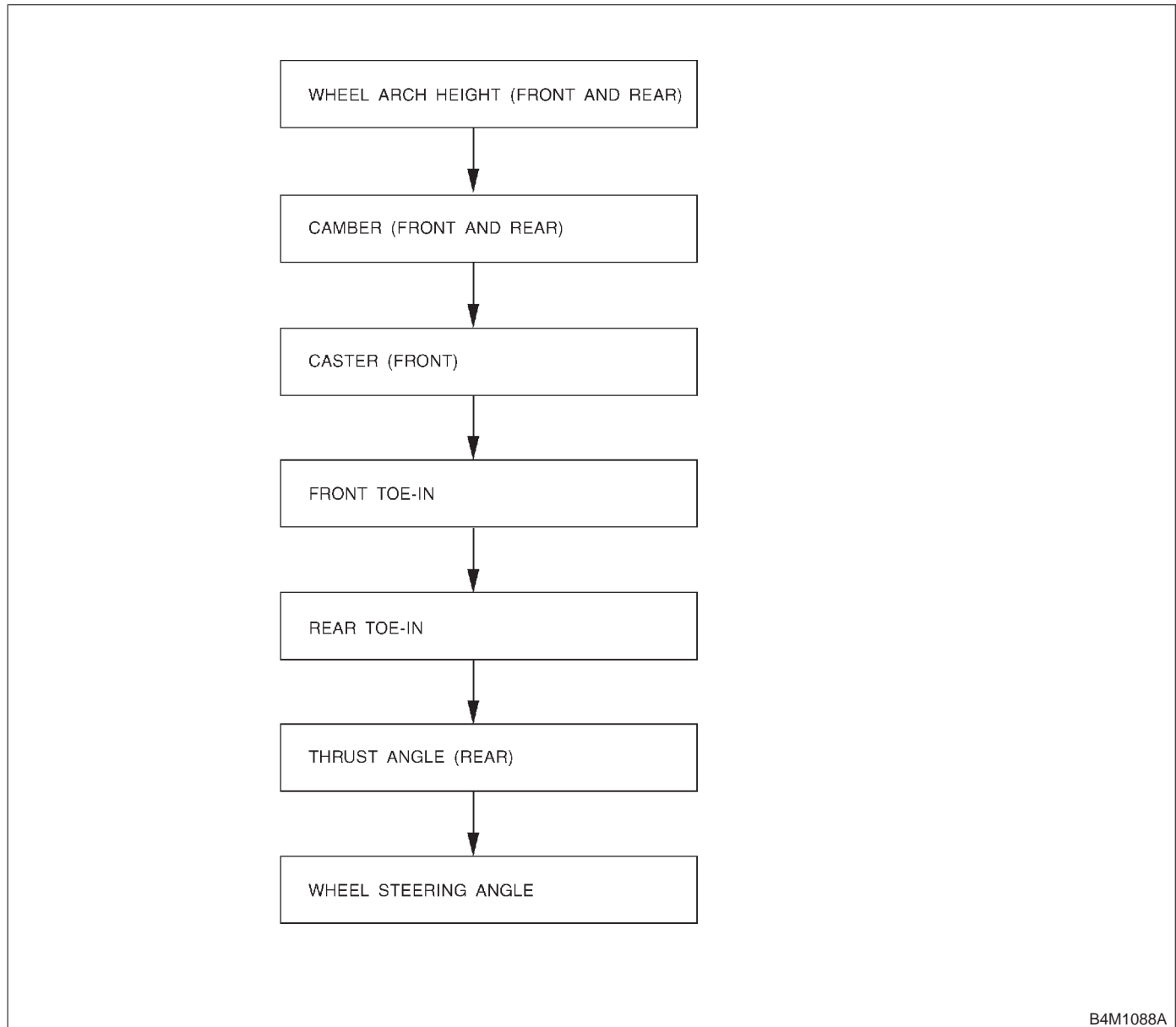

**B: INSPECTION AND ADJUSTMENT**

**1. WHEEL ARCH HEIGHT (FRONT AND REAR)**

- 1) Adjust tire pressure to specifications.
- 2) Set vehicle under "curb weight" conditions. (Empty luggage compartment, install spare tire, jack, service tools, and top up fuel tank.)
- 3) Set steering wheel in a wheel-forward position.
- 4) Suspend thread from wheel arch (point "A" in figure) to determine a point directly above center of spindle.
- 5) Measure distance between measuring point and center of spindle.

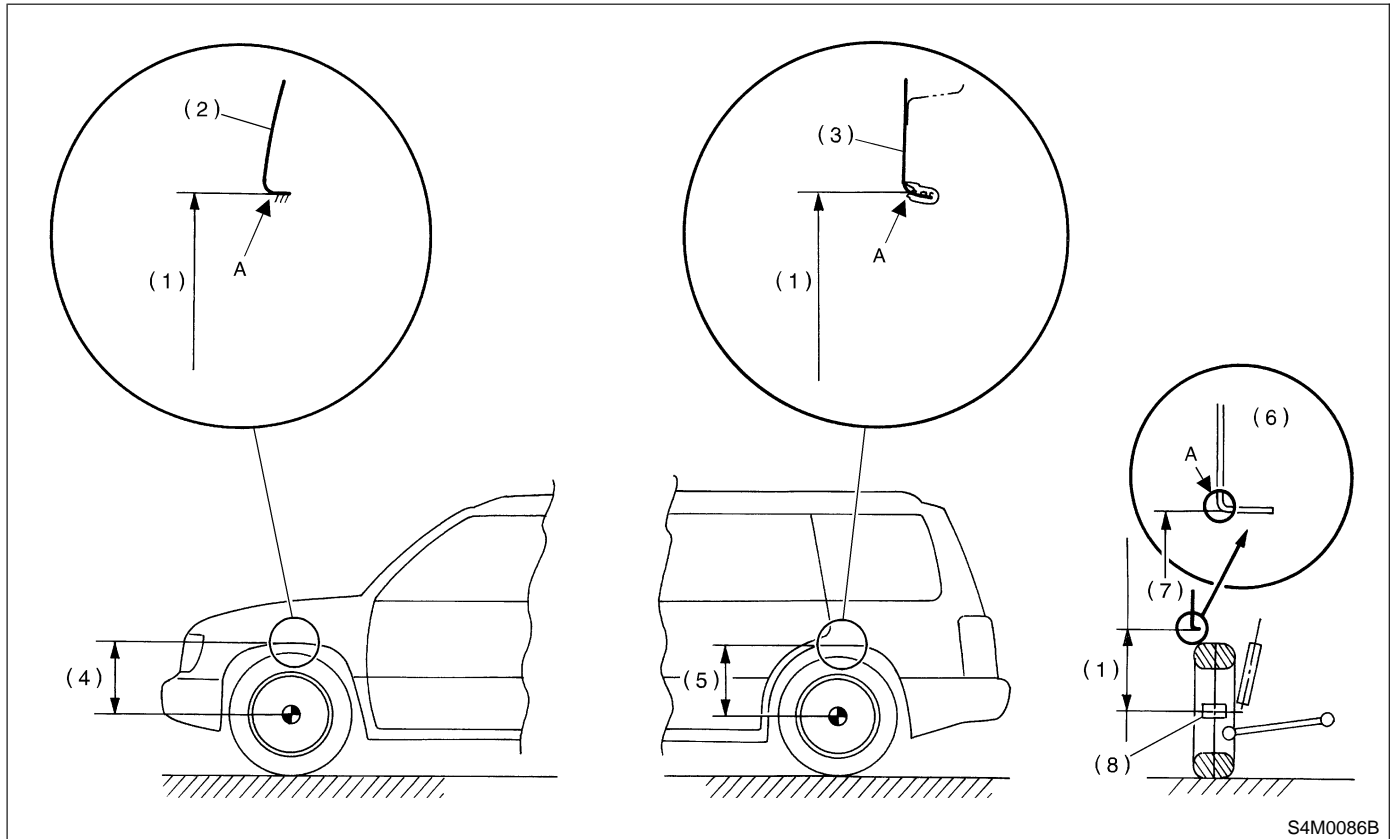

S4M0086B

- |                        |                             |                     |
|------------------------|-----------------------------|---------------------|
| (1) Wheel arch height  | (4) Front wheel arch height | (7) Measuring point |
| (2) Front fender       | (5) Rear wheel arch height  | (8) End of spindle  |
| (3) Outer rear quarter | (6) Cross-section of arch   |                     |

Specified wheel arch height	
Front	Rear
432 <sup>+12</sup> / <sub>-24</sub> mm (17.01 <sup>+0.47</sup> / <sub>-0.94</sub> in)	435 <sup>+12</sup> / <sub>-24</sub> mm (17.13 <sup>+0.47</sup> / <sub>-0.94</sub> in)



2. CAMBER (FRONT AND REAR)

● Inspection

- 1) Place front wheel on turning radius gauge. Make sure ground contacting surfaces of front and rear wheels are set at the same height.
  - 2) Set ST into the center of the wheel, and then install the wheel alignment gauge.
- ST 927380000 ADAPTER

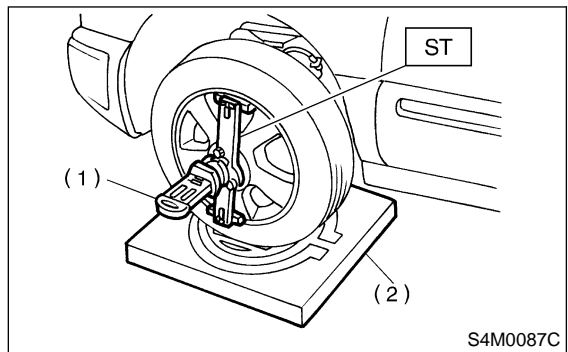

- (1) Alignment gauge
- (2) Turning radius

NOTE:  
Refer to the "SPECIFICATIONS AND SERVICE DATA" for the camber values. <Ref. to 4-1 [S200].>

● Front Camber Adjustment

- 1) Loosen the two self-locking nuts located at lower front portion of strut.

CAUTION:

- When adjusting bolt needs to be loosened or tightened, hold its head with a wrench and turn self-locking nut.
- Discard loosened self-locking nut and replace with a new one.

- 2) Turn camber adjusting bolt so that camber is set at the specification.

NOTE:  
Moving the adjusting bolt by one scale graduation changes camber by approximately 0°10'.

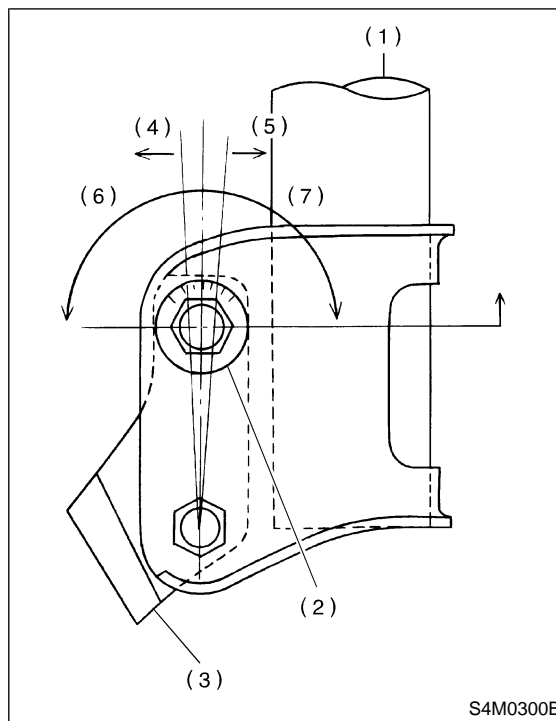

- (1) Strut
- (2) Adjusting bolt
- (3) Housing
- (4) Outer
- (5) Inner
- (6) Camber is increased.
- (7) Camber is decreased.

	Left side	Right side
Camber is increased.	<p>Rotate counterclockwise.</p> <p>S4M0505</p>	<p>Rotate clockwise.</p> <p>S4M0506</p>
Camber is decreased.	<p>Rotate clockwise.</p> <p>S4M0506</p>	<p>Rotate counterclockwise.</p> <p>S4M0505</p>

- 3) Tighten the two self-locking nuts.

**Tightening torque:**  
152±20 N·m (15.5±2.0 kg·m, 112±14 ft·lb)

### 3. CASTER (FRONT)

#### ● Inspection

- 1) Place front wheel on turning radius gauge. Make sure ground contacting surfaces of front and rear wheels are set at the same height.
  - 2) Set ST into the center of the wheel, and then install the wheel alignment gauge.
- ST 927380000 ADAPTER

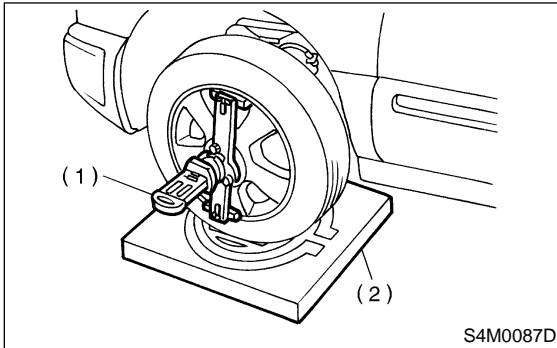

- (1) Alignment gauge
- (2) Turning radius

#### NOTE:

Refer to the "SPECIFICATIONS AND SERVICE DATA" for the caster values. <Ref. to 4-1 [S200].>

### 4. FRONT WHEEL TOE-IN

#### ● Inspection

- 1) Using a toe gauge, measure front wheel toe-in.

#### **Toe-in:**

**$0 \pm 3 \text{ mm } (0 \pm 0.12 \text{ in})$**

- 2) Mark rear sides of left and right tires at height corresponding to center of spindles and measure distance "A" between marks.
- 3) Move vehicle forward so that marks line up with front sides at height corresponding to center of spindles.
- 4) Measure distance "B" between left and right marks. Toe-in can then be obtained by the following equation:

$$A - B = \text{Toe-in}$$

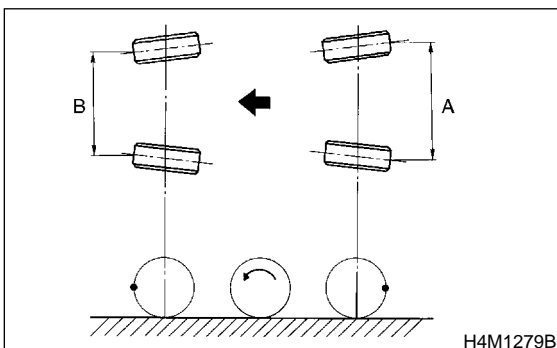

#### ● Adjustment

- 1) Loosen the left and right side steering tie-rods lock nuts.
- 2) Turn the left and right tie rods equal amounts until the toe-in is at the specification. Both the left and right tie-rods are right-hand threaded. To increase toe-in, turn both tie-rods clockwise equal amounts (as viewed from the inside of the vehicle).

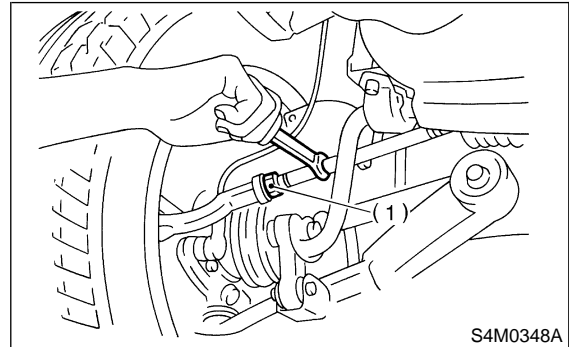

- (1) Lock nut

- 3) Tighten tie-rod lock nut.

#### **Tightening torque:**

**$83 \pm 5 \text{ N-m } (8.5 \pm 0.5 \text{ kg-m, } 61.5 \pm 3.6 \text{ ft-lb})$**

#### **CAUTION:**

**Correct tie-rod boot, if it is twisted.**

#### NOTE:

Check the left and right wheel steering angle is within specifications.

## 5. REAR WHEEL TOE-IN

### ● Inspection

1) Using a toe-in gauge, measure rear wheel toe-in.

#### Toe-in:

**1 — 4 mm (0.04 — 0.16 in)**

2) Mark rear sides of left and right tires at height corresponding to center of spindles and measure distance "A" between marks.

3) Move vehicle forward so that marks line up with front sides at height corresponding to center of spindles.

4) Measure distance "B" between left and right marks. Toe-in can then be obtained by the following equation:

$$A - B = \text{Toe-in}$$

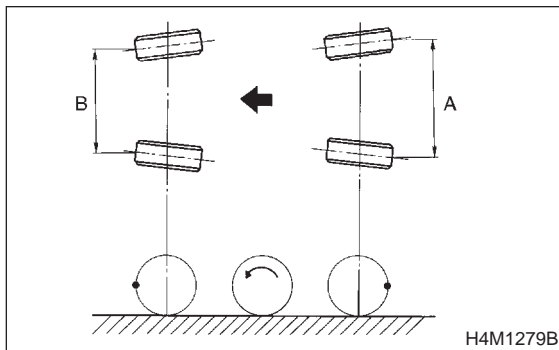

### ● Adjustment

1) Loosen self-locking nut on inner side of rear lateral link.

#### CAUTION:

● When loosening or tightening adjusting bolt, hold bolt head and turn self-locking nut.

● Discard loosened self-locking nut and replace with a new one.

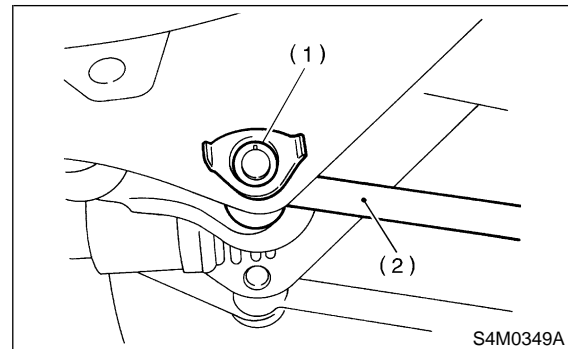

(1) Adjusting scale

(2) Rear lateral link

2) Turn adjusting bolt head until toe-in is at the specification.

#### NOTE:

When left and right wheels are adjusted for toe-in at the same time, the movement of one scale graduation changes toe-in by approximately 3 mm (0.12 in).

	Left side	Right side
Toe-in is increased.	<p>Rotate clockwise.</p> <p>B4M0192</p>	<p>Rotate counterclockwise.</p> <p>B4M0352</p>
Toe-in is decreased.	<p>Rotate counterclockwise.</p> <p>B4M0352</p>	<p>Rotate clockwise.</p> <p>B4M0192</p>

3) Tighten self-locking nut.

#### Tightening torque:

**98±15 N·m (10±1.5 kg·m, 72±11 ft·lb)**

## 6. THRUST ANGLE

### ● Inspection

- 1) Position vehicle on a level surface.
- 2) Move vehicle 3 to 4 meters directly forward.
- 3) Determine locus of both front and rear axles.
- 4) Measure distance "L" between center line of loci of the axles.

### **Thrust angle:**

**Less than 20' when "L" is equal to or less than 15 mm (0.59 in).**

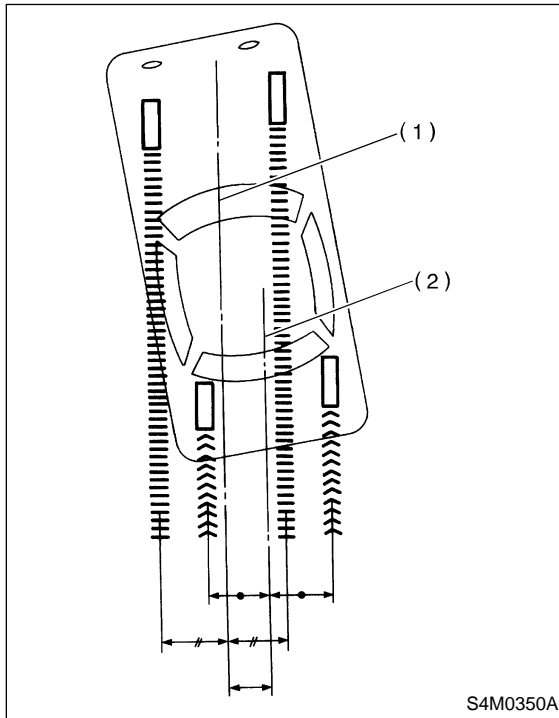

- (1) Center line of loci (front axle)  
 (2) Center line of loci (rear axle)

### ● Adjustment

- 1) Make thrust angle adjustments by turning toe-in adjusting bolts of rear suspension equally in the same direction.
- 2) When one rear wheel is adjusted in a toe-in direction, adjust the other rear wheel equally in toe-out direction, in order to make thrust angle adjustment.
- 3) When left and right adjusting bolts are turned incrementally by one graduation in the same direction, the thrust angle will change approximately 10' ["L" is almost equal to 7.5 mm (0.295 in)].

### **Thrust angle:**

**$0^{\circ} \pm 20'$**

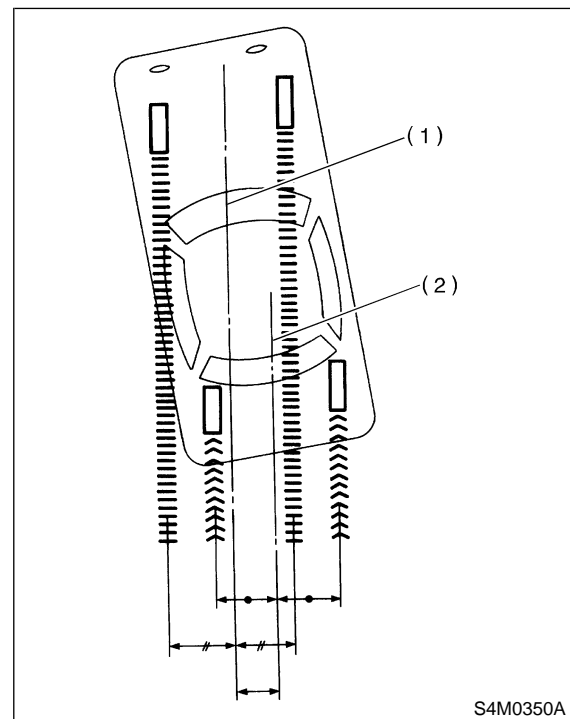

- (1) Center line of loci (front axle)  
 (2) Center line of loci (rear axle)

**NOTE:**

Thrust angle refers to a mean value of left and right rear wheel toe angles in relation to vehicle body center line. Vehicle is driven straight in the thrust angle direction while swinging in the oblique direction depending on the degree of the mean thrust angle.

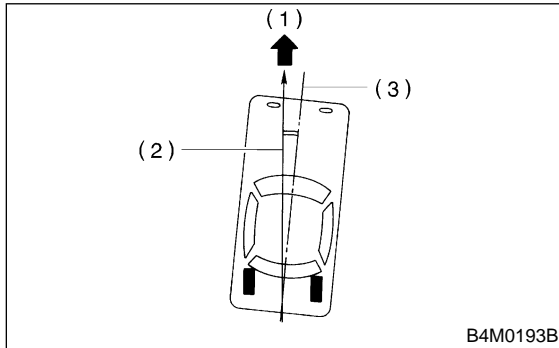

- (1) Front
- (2) Thrust angle
- (3) Body center line

**Thrust angle:**  $r = (\alpha - \beta)/2$

$\alpha$ : Right rear wheel toe angle  
 $\beta$ : Left rear wheel toe angle

**NOTE:**

Here, use only positive toe-in values from each wheel to substitute for  $\alpha$  and  $\beta$  in the equation.

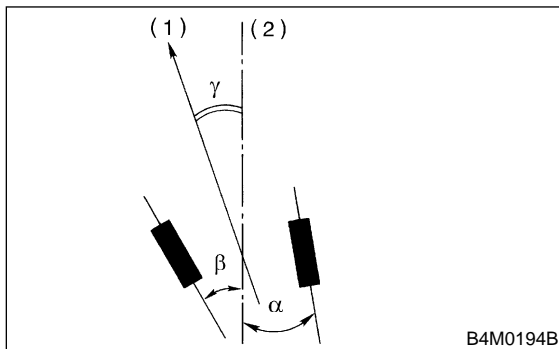

- (1) Front
- (2) Body center line

## 7. STEERING ANGLE

● **Inspection**

- 1) Place vehicle on a turning radius gauge.
- 2) While depressing brake pedal, turn steering wheel fully to the left and right. With steering wheel held at each fully turned position, measure both the inner and outer wheel steering angle.

**Steering angle:**

*Inner wheel*

$34.4^\circ \pm 1.5^\circ$

*Outer wheel*

$30.2^\circ \pm 1.5^\circ$

● **Adjustment**

Turn tie-rod to adjust steering angle of both inner and outer wheels.

**CAUTION:**

- Check toe-in.
- Correct boot if it is twisted.

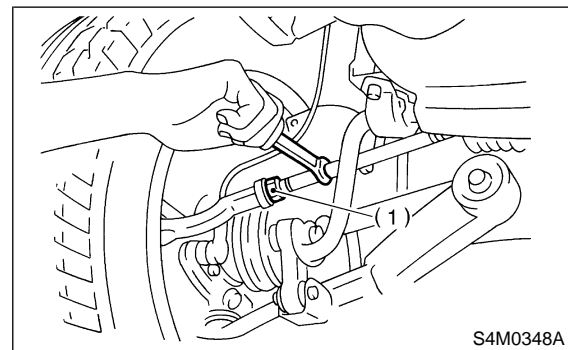

- (1) Lock nut

2. Front Transverse Link

A: REMOVAL

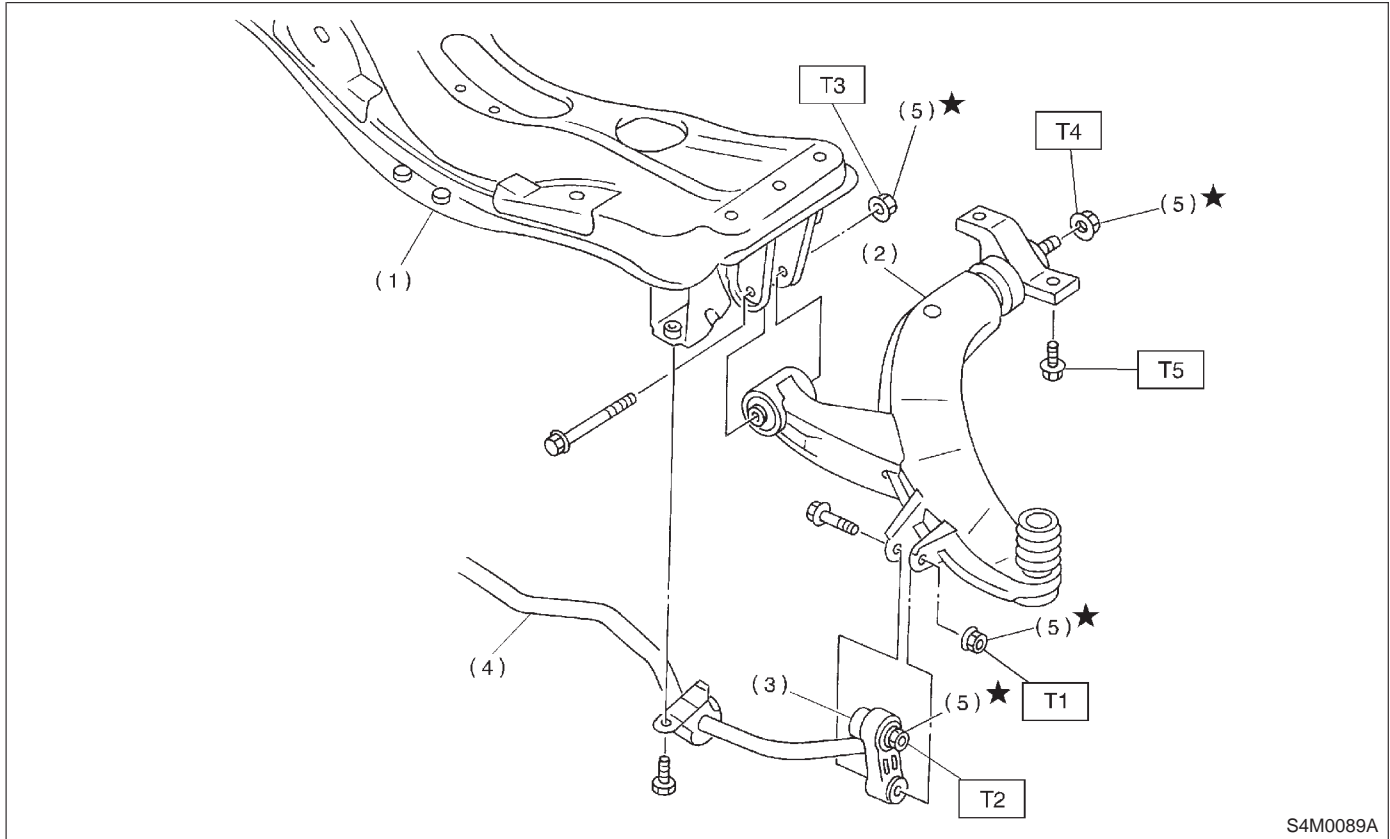

S4M0089A

- (1) Front crossmember
- (2) Transverse link
- (3) Stabilizer link
- (4) Front stabilizer
- (5) Self-locking nut

**Tightening torque: N-m (kg-m, ft-lb)**

**T1: 29±5 (3.0±0.5, 21.7±3.6)**

**T2: 44±6 (4.5±0.6, 32.5±4.3)**

**T3: 98±15 (10.0±1.5, 72±11)**

**T4: 186±10 (19.0±1.0, 137±7)**

**T5: 245±49 (25±5, 181±36)**

- 1) Disconnect stabilizer link from transverse link.
- 2) Remove bolt securing ball joint of transverse link to housing.

- 4) Remove the two bolts securing bushing bracket of transverse link to vehicle body at rear bushing location.

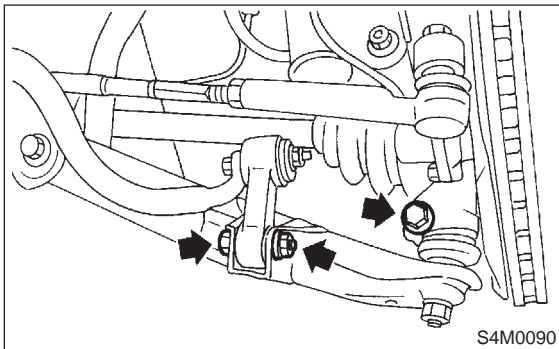

S4M0090

- 3) Remove nut (do not remove bolt.) securing transverse link to crossmember.

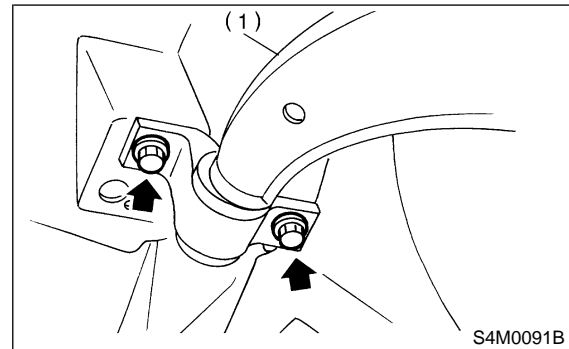

S4M0091B

- (1) Transverse link
- 5) Extract ball joint from housing.

6) Remove bolt securing transverse link to cross-member and extract transverse link from cross-member.

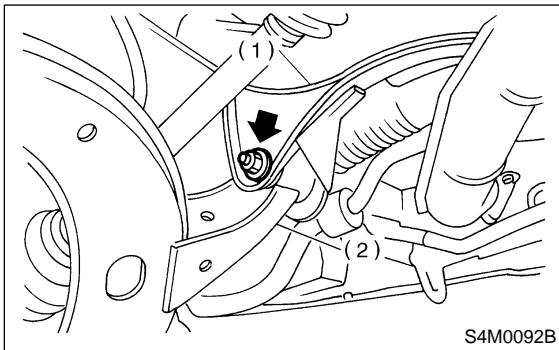

- (1) Front crossmember
- (2) Transverse link

**B: DISASSEMBLY**

**1. FRONT BUSHING**

Using ST, press front bushing out of place.  
ST 927680000 INSTALLER & REMOVER SET

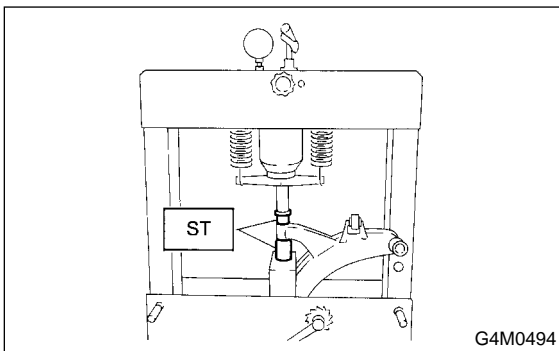

**2. REAR BUSHING**

1) Scribe an aligning mark on transverse link and rear bushing.

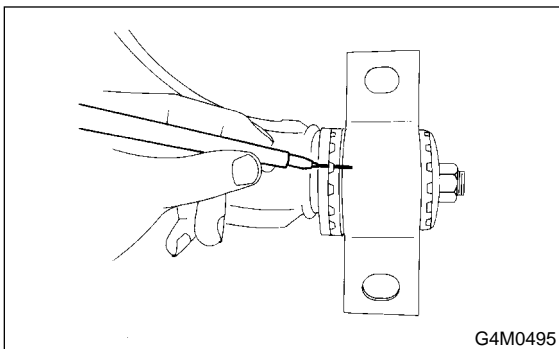

2) Loosen nut and remove rear bushing.

**C: INSPECTION**

- 1) Check transverse link for wear, damage and cracks, and correct or replace if defective.
- 2) Check bushings for cracks, fatigue or damage.
- 3) Check rear bushing for oil leaks.
- 4) If defective, replace with a new one.

**D: ASSEMBLY**

**1. FRONT BUSHING**

Reassemble in the reverse order of disassembly.

**CAUTION:**  
Install front bushing in correct direction, as shown in figure.

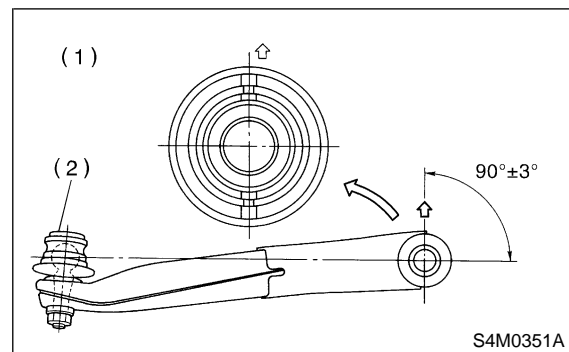

- (1) Face bushing toward center of ball joint.
- (2) Ball joint

**2. REAR BUSHING**

- 1) Install rear bushing to transverse link and align aligning marks scribed on the two.
- 2) Tighten self-locking nut.

**CAUTION:**

- Discard loosened self-locking nut and replace with a new one.
- While holding rear bushing so as not to change position of aligning marks, tighten self-locking nut.

**Tightening torque:**  
**186±10 N·m (19.0±1.0 kg·m, 137±7 ft·lb)**

**E: INSTALLATION**

1) Temporarily tighten the two bolts used to secure rear bushing of the transverse link to body.

**NOTE:**

These bolts should be tightened to such an extent that they can still move back and forth in the oblong shaped hole in the bracket (which holds the bushing).

2) Install bolts used to connect transverse link to crossmember and temporarily tighten with nut.

**CAUTION:**

**Discard loosened self-locking nut and replace with a new one.**

3) Insert ball joint into housing.

4) Connect stabilizer link to transverse link, and temporarily tighten bolts.

**CAUTION:**

**Discard loosened self-locking nut and replace with a new one.**

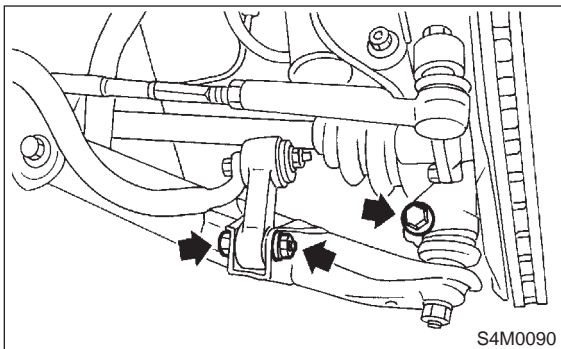

5) Tighten the following points in the order shown below when wheels are in full contact with the ground and vehicle is curb weight.

(1) Transverse link and stabilizer

**Tightening torque:**

**$29 \pm 5$  N·m ( $3.0 \pm 0.5$  kg·m,  $21.7 \pm 3.6$  ft·lb)**

(2) Transverse link and crossmember

**Tightening torque:**

**$98 \pm 15$  N·m ( $10.0 \pm 1.5$  kg·m,  $72 \pm 11$  ft·lb)**

(3) Transverse link rear bushing and body

**Tightening torque:**

**$245 \pm 49$  N·m ( $25 \pm 5$  kg·m,  $181 \pm 36$  ft·lb)**

**NOTE:**

- Move rear bushing back and forth until transverse link-to-rear bushing clearance is established (as indicated in figure.) before tightening.
- Check wheel alignment and adjust if necessary.

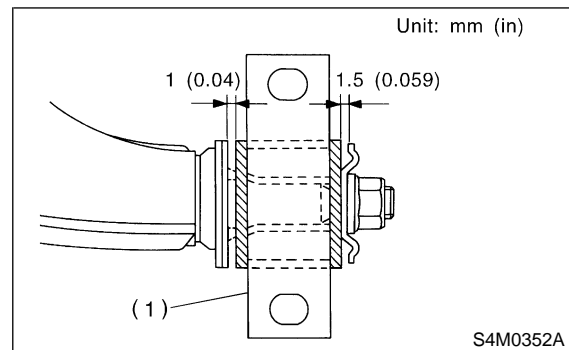

(1) Rear bushing



### 3. Front Ball Joint

#### A: REMOVAL

- 1) Remove the wheel.
- 2) Pull out the cotter pin from the ball stud, remove the castle nut, and extract the ball stud from the transverse link.
- 3) Remove the bolt securing the ball joint to the housing.

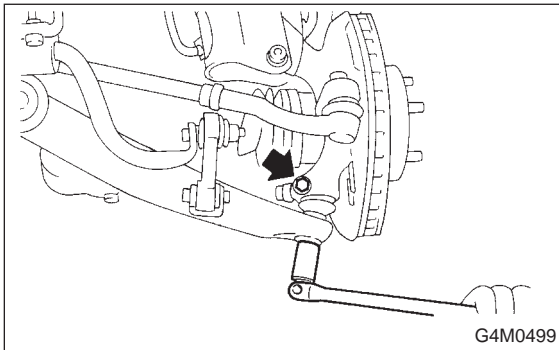

- 4) Extract the ball joint from the housing.

#### B: INSPECTION

- 1) Measure play of ball joint by the following procedures. Replace with a new one when the play exceeds the specified value.

- (1) With 686 N (70 kg, 154 lb) loaded in the direction shown in the figure, measure dimension  $l_1$ .

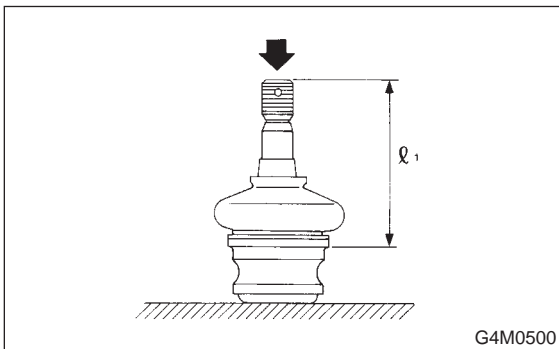

- (2) With 686 N (70 kg, 154 lb) loaded in the opposite direction shown in the figure, measure dimension  $l_2$ .

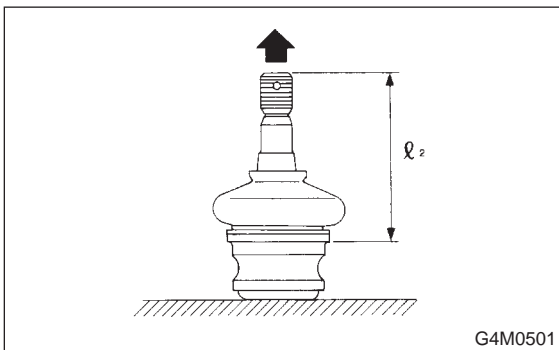

- (3) Calculate plays from the following formula.  
 $S = l_2 - l_1$
- (4) When plays are larger than the following value, replace with a new one.

#### FRONT BALL JOINT

**Specified play for replacement: S**  
**Less than 0.3 mm (0.012 in)**

- 2) When play is smaller than the specified value, visually inspect the dust cover.
- 3) The ball joint and cover that have been removed must be checked for wear, damage or cracks, and any defective part must be replaced.
- 4) If the dust cover is damaged, replace with the new ball joint.

#### C: INSTALLATION

- 1) Install ball joint onto housing.

**Torque (Bolt):**

**$49 \pm 10 \text{ N}\cdot\text{m}$  ( $5.0 \pm 1.0 \text{ kg}\cdot\text{m}$ ,  $36 \pm 7 \text{ ft}\cdot\text{lb}$ )**

**CAUTION:**

**Do not apply grease to tapered portion of ball stud.**

- 2) Connect ball joint to transverse link.

**Torque (Castle nut):**

**$39 \text{ N}\cdot\text{m}$  ( $4.0 \text{ kg}\cdot\text{m}$ ,  $29 \text{ ft}\cdot\text{lb}$ )**

- 3) Retighten castle nut further within 60° until a slot in castle nut is aligned with the hole in ball stud end, then insert new cotter pin and bend it around castle nut.
- 4) Install front wheel.

## 4. Front Strut

### A: REMOVAL

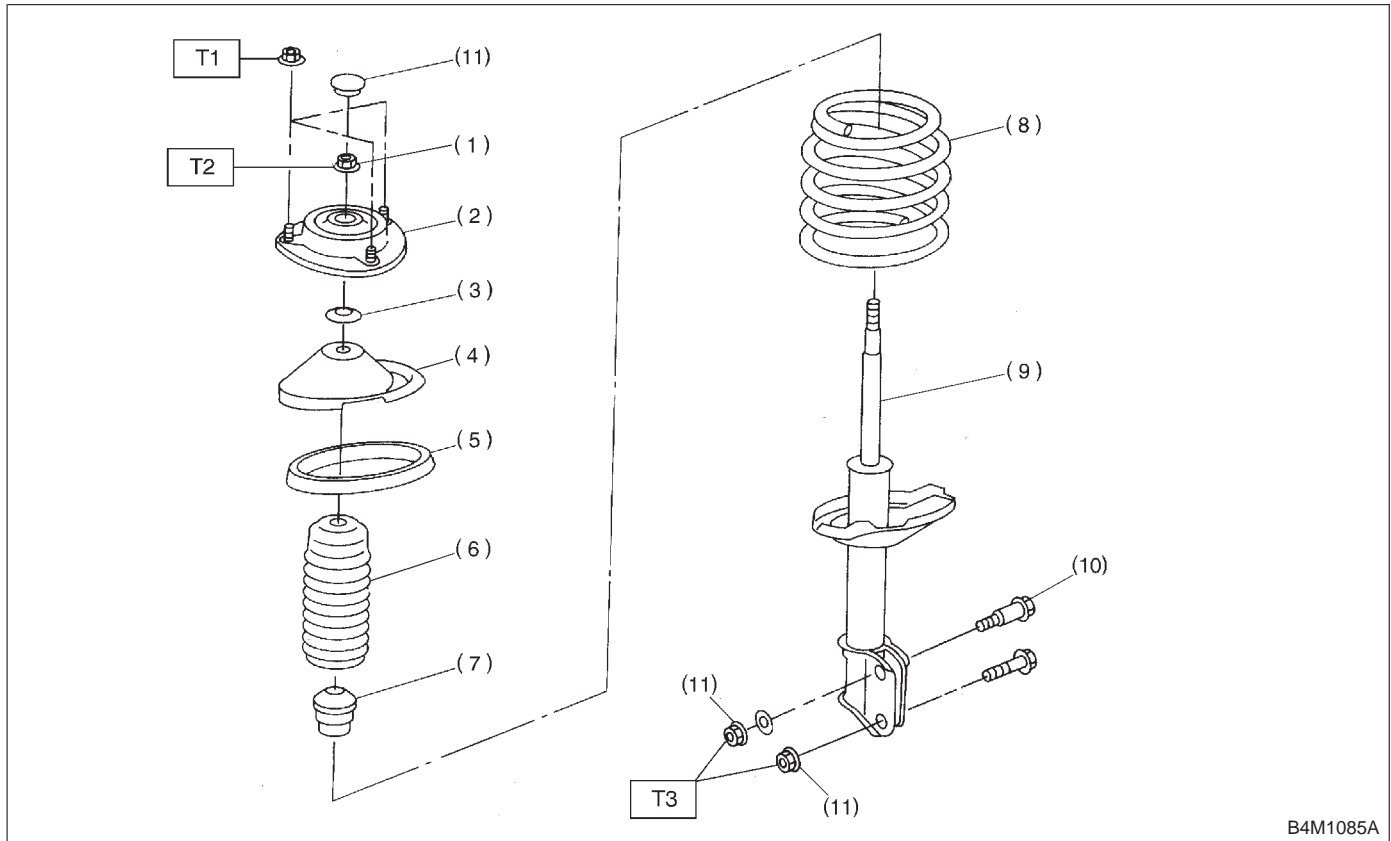

- (1) Dust seal
- (2) Strut mount
- (3) Spacer
- (4) Upper spring seat
- (5) Rubber seat
- (6) Dust cover
- (7) Helper
- (8) Coil spring
- (9) Damper strut
- (10) Adjusting bolt
- (11) Self-locking nut

**Tightening torque: N·m (kg·m, ft·lb)**

**T1: 20±6 (2.0±0.6, 14.5±4.3)**

**T2: 54±5 (5.5±0.5, 39.8±3.6)**

**T3: 152±20 (15.5±2.0, 112±14)**

- 1) Remove wheel.
- 2) Depress brake pedal and hold it down using a wooden block etc.
- 3) Remove union bolts from caliper.

**CAUTION:**

**Use brake hose cap to prevent brake fluid from escaping.**

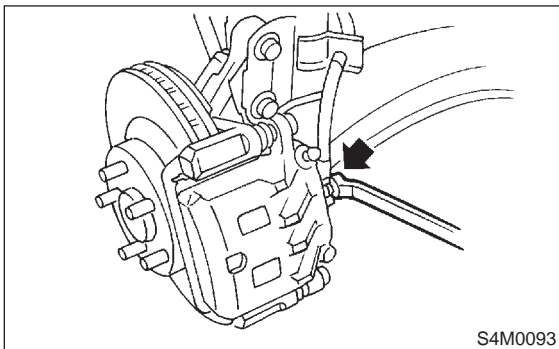

- 4) Remove brake hose clamp and disconnect brake hose from strut. Attach brake hose to body using gum tape.

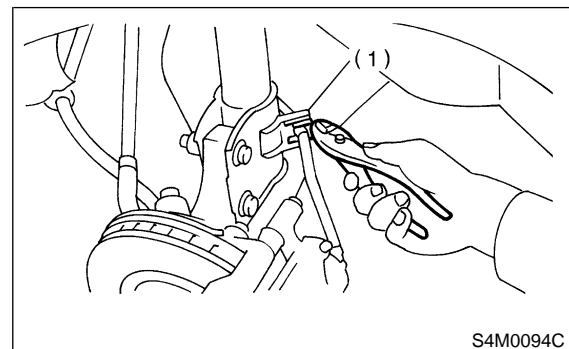

- (1) Clamp

- 5) Scribe an alignment mark on the camber adjusting bolt which secures strut to housing.
- 6) Remove bolt securing the ABS sensor harness.

7) Remove the two bolts securing housing to strut.

**CAUTION:**

**While holding head of adjusting bolt, loosen self-locking nut.**

8) Remove the three nuts securing strut mount to body.

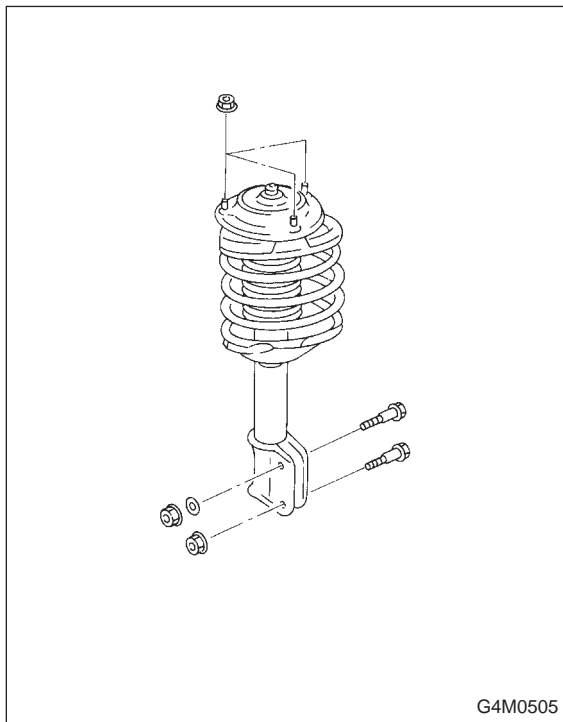

G4M0505

**B: DISASSEMBLY**

1) Using a coil spring compressor, compress coil spring.

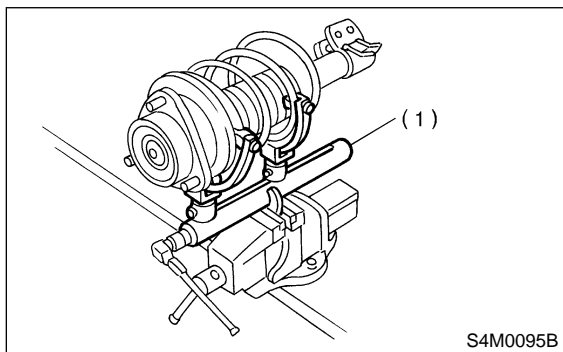

S4M0095B

(1) Coil spring compressor

2) Using ST, remove self-locking nut.  
ST 927760000 STRUT MOUNT SOCKET

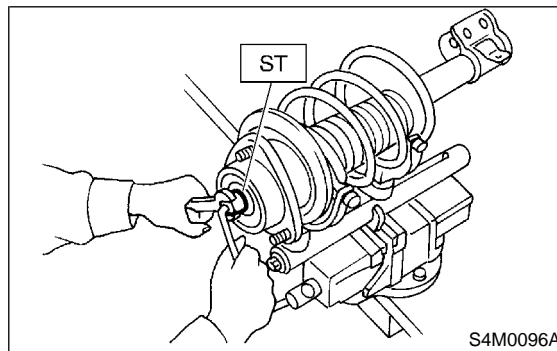

S4M0096A

- 3) Remove strut mount, upper spring seat and rubber seat from strut.
- 4) Gradually decreasing compression force, and remove coil spring.
- 5) Remove dust cover and helper spring.

**C: INSPECTION**

Check the disassembled parts for cracks, damage and wear, and replace with new parts if defective.

**1. DAMPER STRUT**

- 1) Check for oil leakage.
- 2) Move the piston rod up and down to check it operates smoothly without any binding.
- 3) Play of piston rod
  - Measure the play as follows:  
Fix outer shell and fully extend the rod. Set a dial gauge at the end of the rod: L [10 mm (0.39 in)], then apply a force of W [20 N (2 kg, 4 lb)] to threaded portion. With the force of 20 N (2 kg, 4 lb) applied, read dial gauge indication: P<sub>1</sub>. Apply a force of 20 N (2 kg, 4 lb) in the opposite direction of "W", then read dial gauge indication: P<sub>2</sub>.

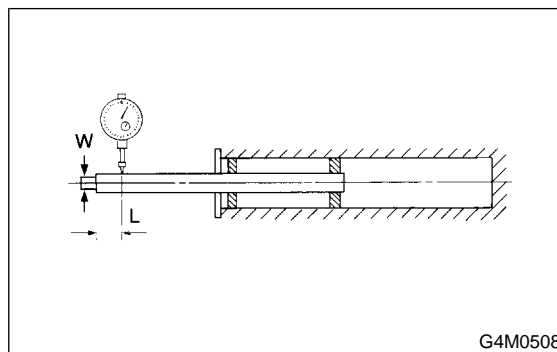

G4M0508

The free play is determined by the following equation:

$$Play = P_1, P_2$$

**Limit of play:**

**Less than 0.8 mm (0.031 in)**

If the play is greater, replace the strut.

## 2. STRUT MOUNT

Check rubber part for creep, cracks and deterioration, and replace it with new one if defective.

## 3. DUST COVER

If any cracks or damage are found, replace it with a new one.

## 4. COIL SPRING

One having permanent strain should be replaced with a new one. When vehicle posture is uneven, although there are no considerable reasons like tire puncture, uneven loading, etc., check coil spring for its free length referring to specifications, cracks, etc., and replace it with a new one if defective.

## 5. HELPER

Replace it with a new one if cracked or damaged.

## D: ASSEMBLY

1) Before installing coil spring, strut mount, etc., on the strut, check for the presence of air in the dampening force generating mechanism of the strut since air prevents proper dampening force from being produced.

2) Checking for the presence of air

(1) Place the strut vertically with the piston rod facing up.

(2) Move the piston rod to the center of its entire stroke.

(3) While holding the piston rod end with fingertips, move the rod up and down.

(4) If the piston rod moves at least 10 mm (0.39 in) in the former step, purge air from the strut.

3) Air purging procedure

(1) Place the strut vertically with the piston rod facing up.

(2) Fully extend the piston rod.

(3) With the piston rod fully extended, place the piston rod side down. The strut must stand vertically.

(4) Fully contract the piston rod.

(5) Repeat 3 or 4 times from the first step.

### NOTE:

After completely purging air from the strut, be sure to place the strut with the piston rod facing up. If it is laid down, check for entry of air in the strut as outlined under "Checking for the presence of air".

4) Using a coil spring compressor, compress the coil spring.

### NOTE:

Make sure that the vertical installing direction of coil spring is as shown in figure.

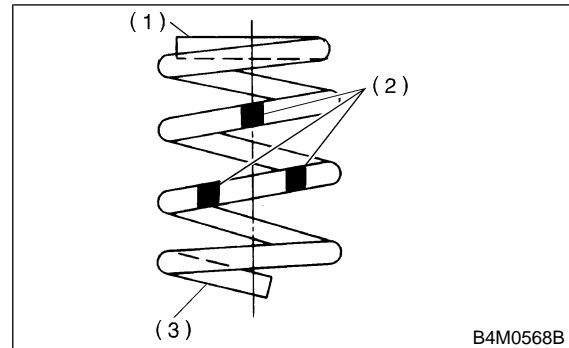

- (1) Flat (top side)
- (2) Identification paint
- (3) Inclined (bottom side)

5) Set the coil spring correctly so that its end face fits well into the spring seat as shown.

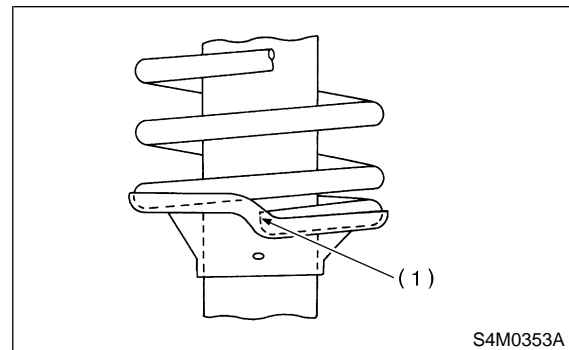

- (1) End face

6) Install a helper and dust cover to the piston rod.  
7) Pull the piston rod fully upward, and install rubber seat and spring seat.

### NOTE:

Ensure that upper spring seat is positioned as shown in figure.

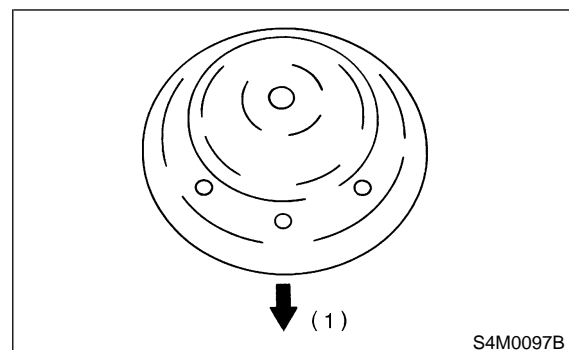

- (1) Outside of body

8) Install strut mount to the piston rod, and tighten the self-locking nut temporarily.

**CAUTION:**

**Be sure to use a new self-locking nut.**

9) Using a hexagon wrench to prevent strut rod from turning, tighten self-locking nut with ST.  
ST 927760000 STRUT MOUNT SOCKET

**Tightening torque:**

**$54\pm 5$  N·m ( $5.5\pm 0.5$  kg·m,  $39.8\pm 3.6$  ft·lb)**

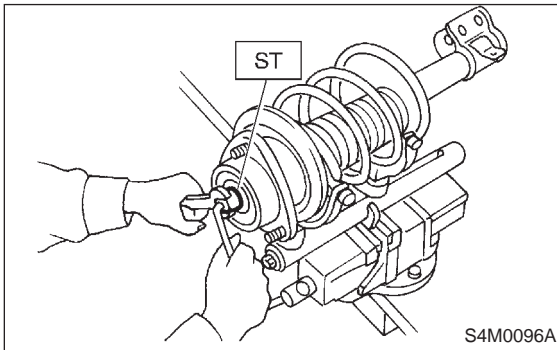

10) Loosen the coil spring carefully.

**E: INSTALLATION**

1) Install strut mount at upper side of strut to body and tighten with nuts.

**Tightening torque:**

**$20\pm 6$  N·m ( $2.0\pm 0.6$  kg·m,  $14.5\pm 4.3$  ft·lb)**

2) Install ABS sensor harness to strut.

**Tightening torque:**

**$32\pm 10$  N·m ( $3.3\pm 1.0$  kg·m,  $24\pm 7$  ft·lb)**

3) Position aligning mark on camber adjustment bolt with aligning mark on lower side of strut.

**CAUTION:**

- While holding head of adjusting bolt, tighten self-locking nut.
- Be sure to use new self-locking nut.

**Tightening torque:**

**$152\pm 20$  N·m ( $15.5\pm 2.0$  kg·m,  $112\pm 14$  ft·lb)**

4) Install brake hose at lower side of strut with clamp.

5) Install union bolts which secure brake caliper to brake hose.

**Tightening torque:**

**$18\pm 3$  N·m ( $1.8\pm 0.3$  kg·m,  $13.0\pm 2.2$  ft·lb)**

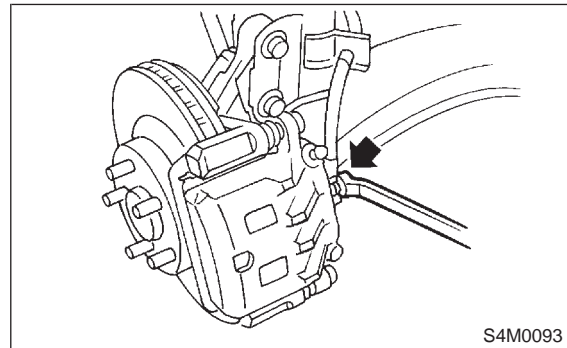
**CAUTION:**

**Be sure to bleed air from brake system.**

6) Install wheels.

**NOTE:**

Check wheel alignment and adjust if necessary.

## 5. Front Stabilizer

### A: REMOVAL

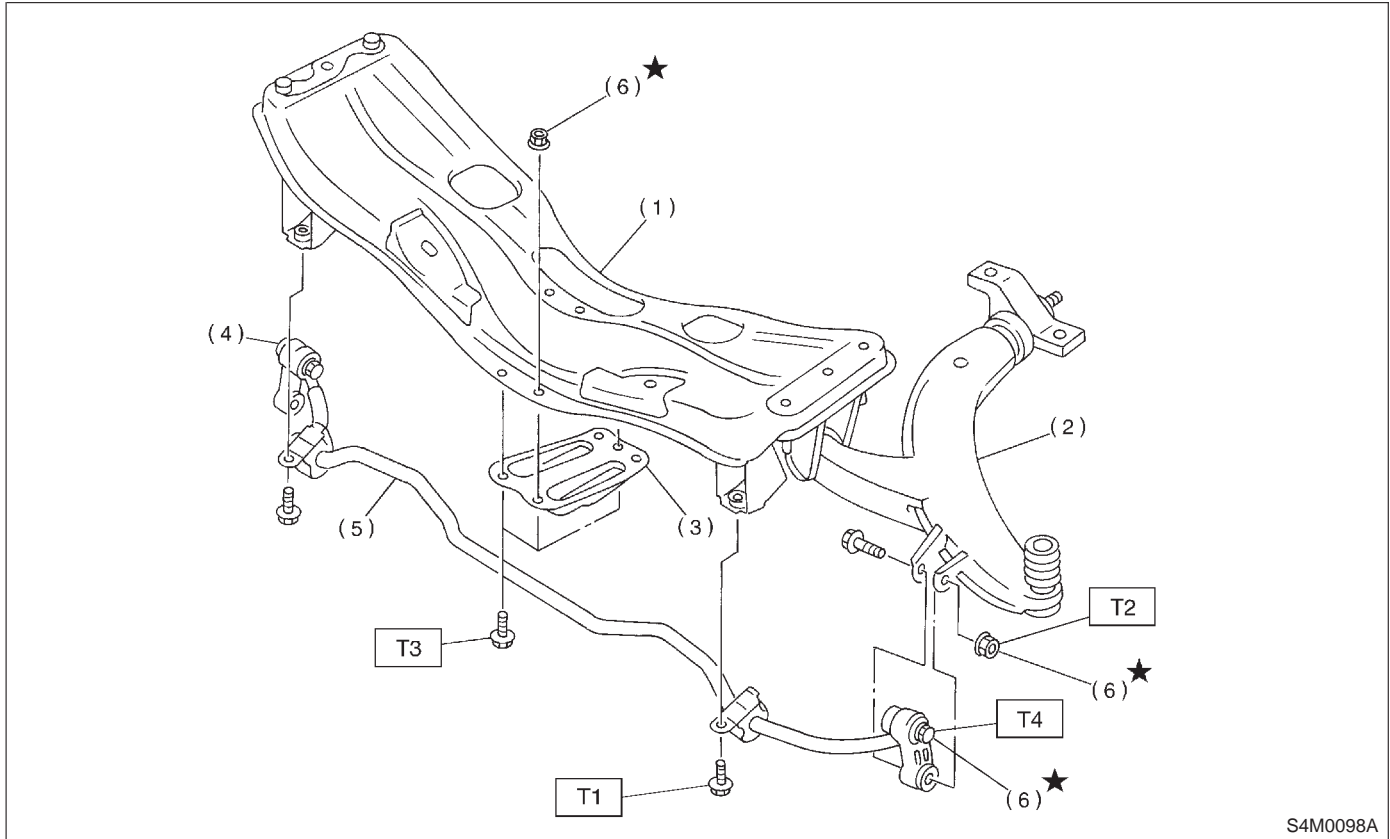

- (1) Front crossmember
- (2) Transverse link
- (3) Jack-up plate
- (4) Stabilizer link
- (5) Front stabilizer
- (6) Self-locking nut

**Tightening torque: N·m (kg·m, ft·lb)**

**T1: 25±4 (2.5±0.4, 18.1±2.9)**

**T2: 29±5 (3.0±0.5, 21.7±3.6)**

**T3: 18±5 (1.8±0.5, 13.0±3.6)**

**T4: 44±6 (4.5±0.6, 32.5±4.3)**

- 1) Jack-up the front part of the vehicle and support it with safety stand (rigid racks).
- 2) Remove bolts which secure stabilizer to crossmember.

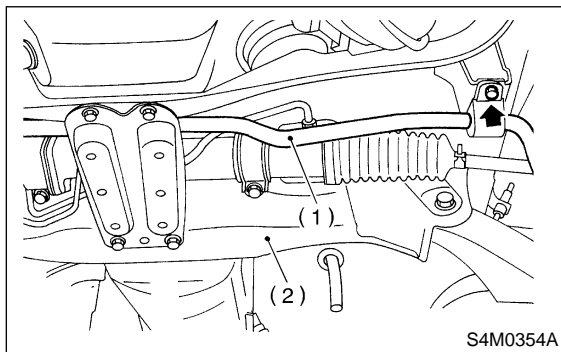

- (1) Front stabilizer
- (2) Front crossmember

- 3) Remove bolts which secure stabilizer link to front transverse link.

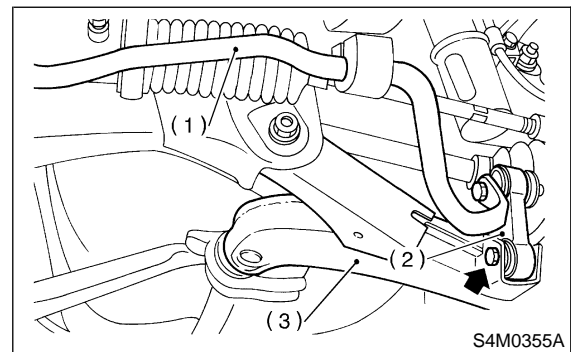

- (1) Stabilizer
- (2) Stabilizer link
- (3) Transverse link

- 4) Remove jack-up plate from lower part of crossmember.

**B: INSPECTION**

- 1) Check bushing for cracks, fatigue or damage.
- 2) Check stabilizer link for deformities, cracks, or damage, and bushing for protrusions from the hole of stabilizer link.

**C: INSTALLATION**

- 1) Install in the reverse order of removal.

**NOTE:**

- Install bushing (on front crossmember side) while aligning it with paint mark on stabilizer.
- Ensure that bushing and stabilizer have the same identification colors when installing.

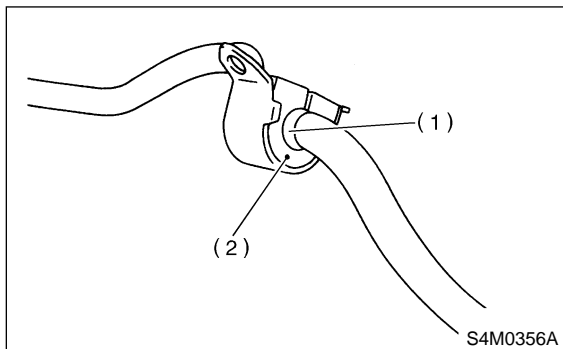

- (1) Mark stamped on stabilizer
- (2) Bushing identification color

- 2) Always tighten rubber bushing location when wheels are in full contact with the ground and vehicle is curb weight.

**Tightening torque:****Jack-up plate to crossmember:**

**18±5 N·m (1.8±0.5 kg·m, 13.0±3.6 ft·lb)**

**Stabilizer link to front transverse link:**

**29±5 N·m (3.0±0.5 kg·m, 21.7±3.6 ft·lb)**

**Stabilizer to crossmember:**

**25±4 N·m (2.5±0.4 kg·m, 18.1±2.9 ft·lb)**

**6. Front Crossmember****A: REMOVAL**

- 1) Disconnect ground cable from battery.
- 2) Loosen front wheel nuts.
- 3) Jack-up vehicle, support it with safety stands (rigid racks), and remove front tires and wheels.
- 4) Remove both stabilizer and jack-up plate.

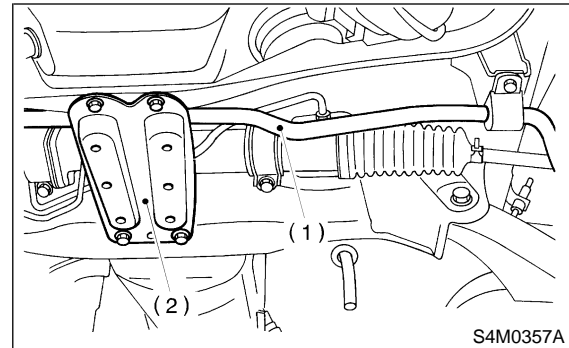

- (1) Front stabilizer
- (2) Jack-up plate

- 5) Disconnect tie-rod end from housing.
- 6) Remove front exhaust pipe.
- 7) Remove front transverse link from front crossmember and body.

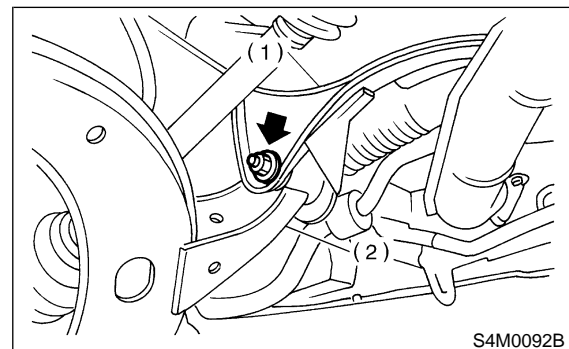

- (1) Front crossmember
- (2) Transverse link

- 8) Remove nuts attaching engine mount cushion rubber to crossmember.
- 9) Remove self-locking nuts connecting steering U/J and pinion shaft.
- 10) Lift engine by approx. 10 mm (0.39 in) by using chain block.
- 11) Support crossmember with a jack, remove nuts securing crossmember to body and lower crossmember gradually along with steering gear-box.

**CAUTION:**

**When removing crossmember downward, be careful that tie-rod end does not interfere with DOJ boot.**

**B: INSPECTION**

- 1) Check bushing for cracks, fatigue or damage.
- 2) Check stabilizer link for deformities, cracks, or damage, and bushing for protrusions from the hole of stabilizer link.

**C: INSTALLATION**

- 1) Install in the reverse order of removal.

**NOTE:**

- Install bushing (on front crossmember side) while aligning it with paint mark on stabilizer.
- Ensure that bushing and stabilizer have the same identification colors when installing.

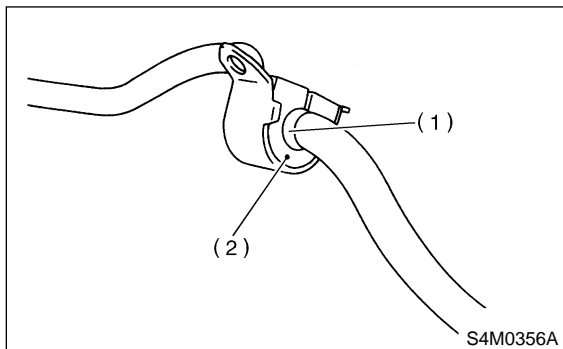

- (1) Mark stamped on stabilizer
- (2) Bushing identification color

- 2) Always tighten rubber bushing location when wheels are in full contact with the ground and vehicle is curb weight.

**Tightening torque:****Jack-up plate to crossmember:**

**18±5 N·m (1.8±0.5 kg·m, 13.0±3.6 ft·lb)**

**Stabilizer link to front transverse link:**

**29±5 N·m (3.0±0.5 kg·m, 21.7±3.6 ft·lb)**

**Stabilizer to crossmember:**

**25±4 N·m (2.5±0.4 kg·m, 18.1±2.9 ft·lb)**

**6. Front Crossmember****A: REMOVAL**

- 1) Disconnect ground cable from battery.
- 2) Loosen front wheel nuts.
- 3) Jack-up vehicle, support it with safety stands (rigid racks), and remove front tires and wheels.
- 4) Remove both stabilizer and jack-up plate.

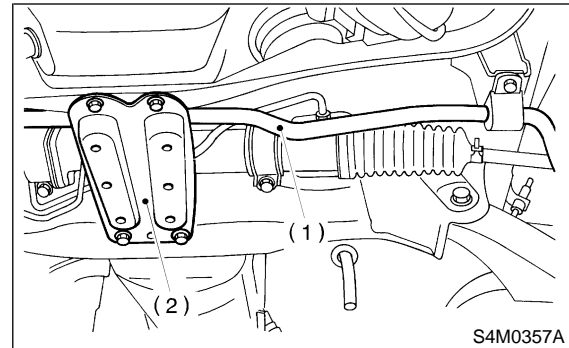

- (1) Front stabilizer
- (2) Jack-up plate

- 5) Disconnect tie-rod end from housing.
- 6) Remove front exhaust pipe.
- 7) Remove front transverse link from front crossmember and body.

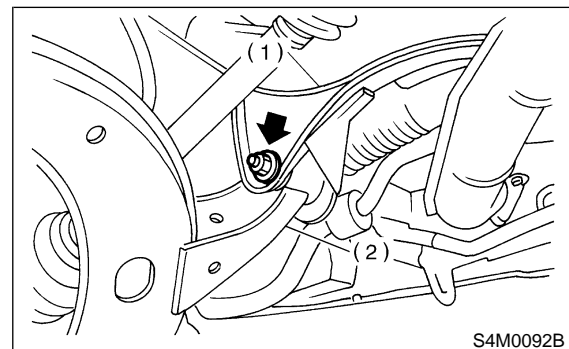

- (1) Front crossmember
- (2) Transverse link

- 8) Remove nuts attaching engine mount cushion rubber to crossmember.
- 9) Remove self-locking nuts connecting steering U/J and pinion shaft.
- 10) Lift engine by approx. 10 mm (0.39 in) by using chain block.
- 11) Support crossmember with a jack, remove nuts securing crossmember to body and lower crossmember gradually along with steering gear-box.

**CAUTION:**

**When removing crossmember downward, be careful that tie-rod end does not interfere with DOJ boot.**



## B: INSTALLATION

1) Install in the reverse order of removal.

### CAUTION:

Always tighten rubber bushing when wheels are in full contact with the ground and vehicle is curb weight.

### *Tightening torque:*

*Transverse link bushing to crossmember:*

***98±15 N·m (10.0±1.5 kg·m, 72±11 ft·lb)***

*Stabilizer to bushing:*

***25±4 N·m (2.5±0.4 kg·m, 18.1±2.9 ft·lb)***

*Tie-rod end to housing:*

***27.0±2.5 N·m (2.75±0.25 kg·m, 19.9±1.8 ft·lb)***

*Front cushion rubber to crossmember:*

***85±15 N·m (8.7±1.5 kg·m, 63±11 ft·lb)***

*Universal joint to pinion shaft:*

***24±3 N·m (2.4±0.3 kg·m, 17.4±2.2 ft·lb)***

*Crossmember to body:*

***98±15 N·m (10.0±1.5 kg·m, 72±11 ft·lb)***

2) Purge air from power steering system.

### NOTE:

Check wheel alignment and adjust if necessary.

## 7. Rear Trailing Link

### A: REMOVAL

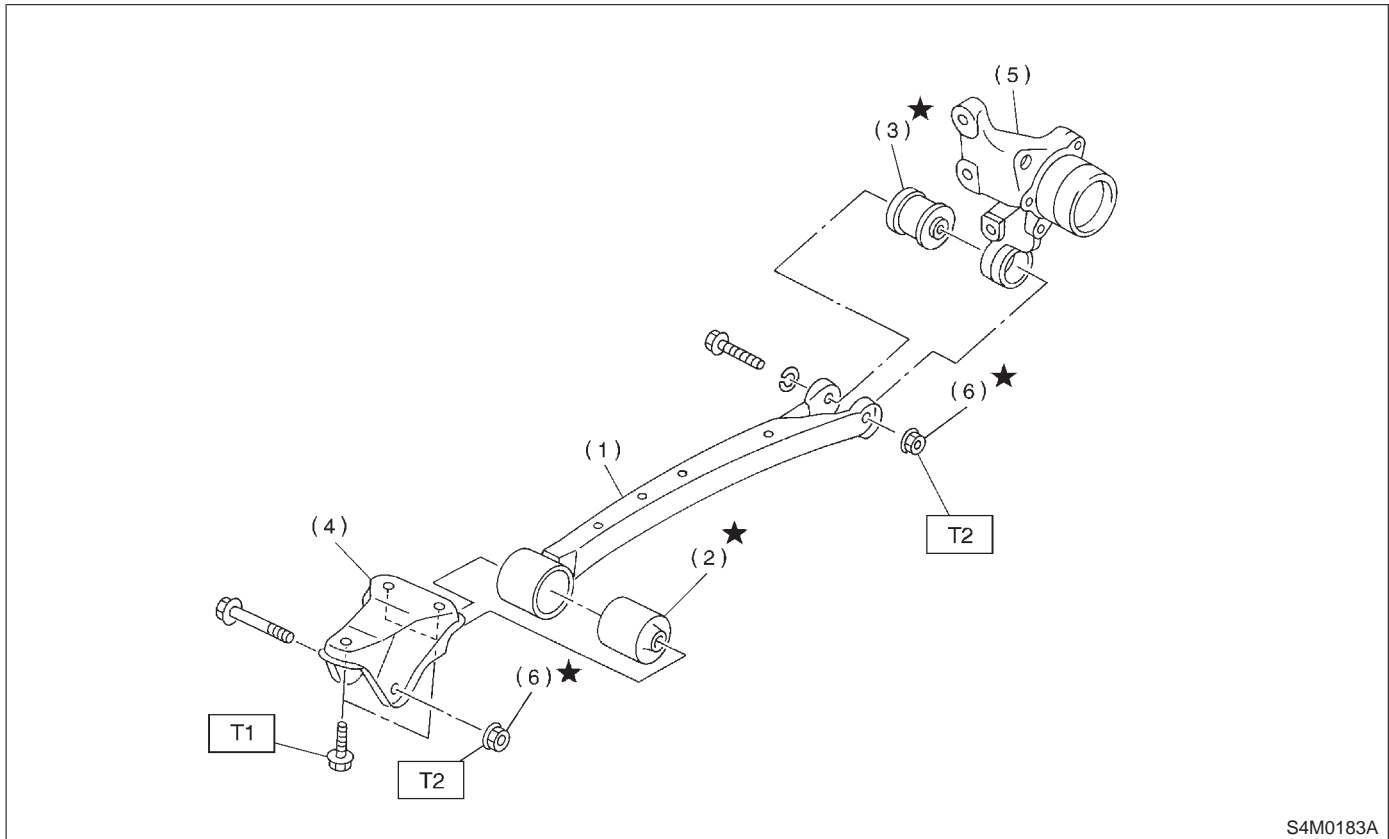

S4M0183A

- |                   |                      |
|-------------------|----------------------|
| (1) Trailing link | (5) Housing          |
| (2) Front bushing | (6) Self-locking nut |
| (3) Rear bushing  |                      |
| (4) Bracket       |                      |

**Tightening torque: N·m (kg·m, ft·lb)**

**T1: 98±20 (10.0±2.0, 72±14)**

**T2: 113±15 (11.5±1.5, 83±11)**

- 1) Loosen rear wheel nuts.
- 2) Jack-up vehicle, support it with safety stands (rigid racks) and remove rear wheels.
- 3) Remove both rear parking brake clamp and ABS sensor harness.
- 4) Remove bolt which secure trailing link to trailing link bracket.

- 5) Remove bolt which secure trailing link to rear housing.

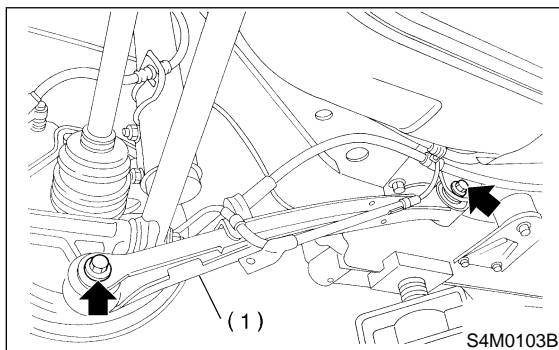

S4M0103B

- (1) Trailing link

**B: DISASSEMBLY**

**1. FRONT BUSHING**

Using ST, press front bushing out of place.  
ST 927720000 INSTALLER & REMOVER SET

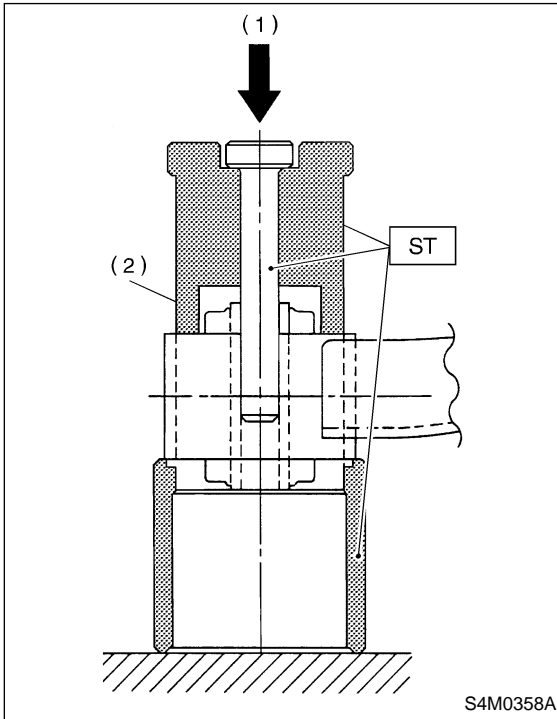

- (1) Press
- (2) Trailing link

**2. REAR BUSHING**

1) Remove housing. For removal procedures;  
<Ref. to 4-2 [W2A0].>  
2) Using ST, press rear bushing out of place.  
ST 927730000 INSTALLER & REMOVER SET

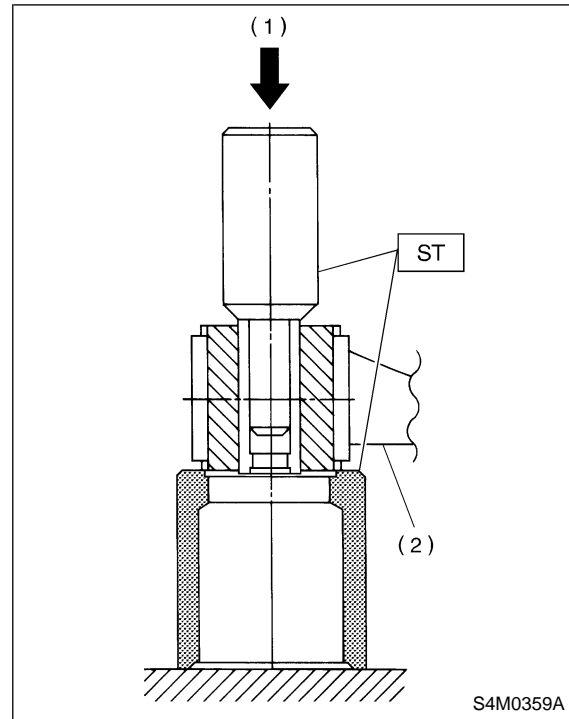

- (1) Press
- (2) Housing

**C: INSPECTION**

Check trailing links for bends, corrosion or damage.

**D: ASSEMBLY**

Assemble in the reverse order of disassembly.

**1. FRONT BUSHING**

Using ST, press bushing into trailing link.  
ST 927720000 INSTALLER & REMOVER SET

**CAUTION:**

When installing bushing, turn ST plunger upside down and press it until plunger end surface contacts trailing link end surface.

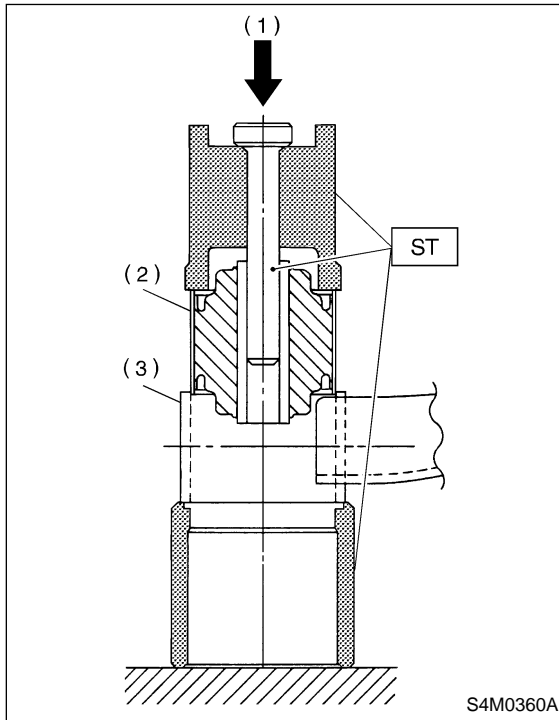

- (1) Press
- (2) Front bushing
- (3) Trailing link

**CAUTION:**

Install front bushing in the proper direction, as shown in figure.

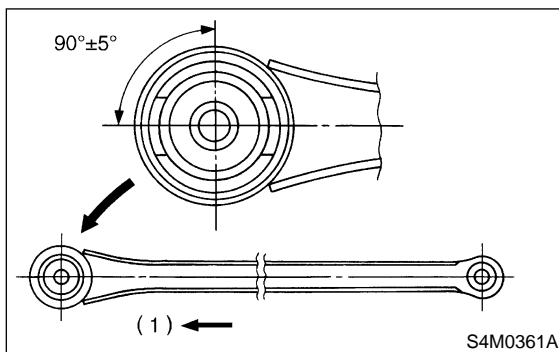

- (1) Front

**2. REAR BUSHING**

1) Using ST, press bushing into trailing link.  
ST 927730000 INSTALLER & REMOVER SET

**NOTE:**

If it is difficult to press bushing into trailing link, apply water-diluted TIRE LUBE to the inner surface of ST as a lubricant.

**Specified lubricant:**

**TIRE LUBE : water = 1 : 3**

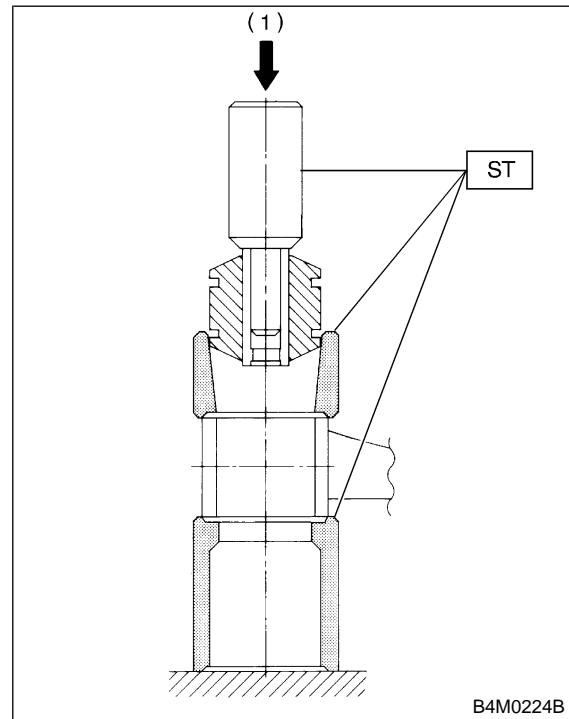

- (1) Press

2) Press ST plunger until bushing flange protrudes beyond trailing link.

ST 927730000 INSTALLER & REMOVER SET

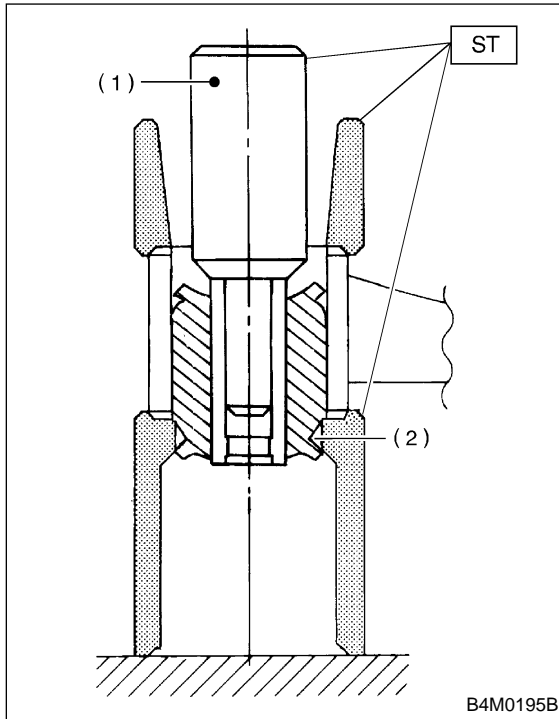

- (1) Plunger
- (2) Flange

3) Turn trailing link upside down. Press ST plunger in the direction opposite that outlined in the former procedure until bushing is correctly positioned in trailing link.

ST 927730000 INSTALLER & REMOVER SET

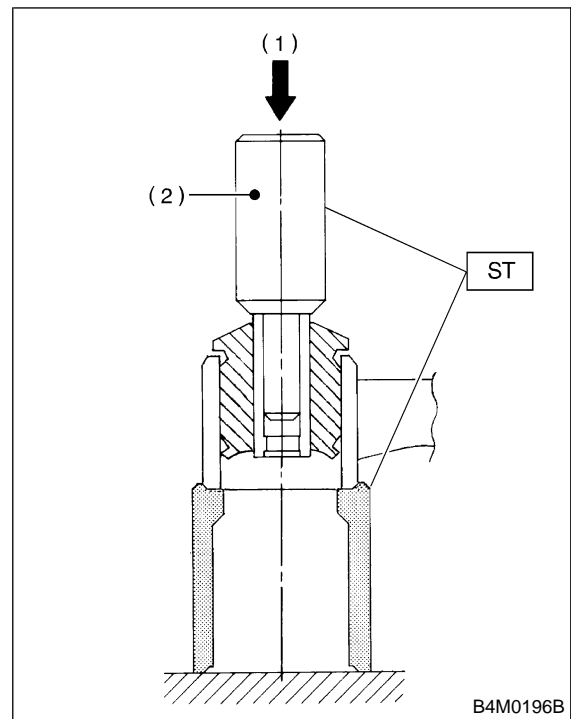

- (1) Press
- (2) Plunger

## E: INSTALLATION

Install in the reverse order of removal.

### CAUTION:

**Always tighten rubber bushing location when wheels are in full contact with the ground and vehicle is at curb weight condition.**

### NOTE:

Check wheel alignment and adjust if necessary.

## 8. Lateral Link

### A: REMOVAL

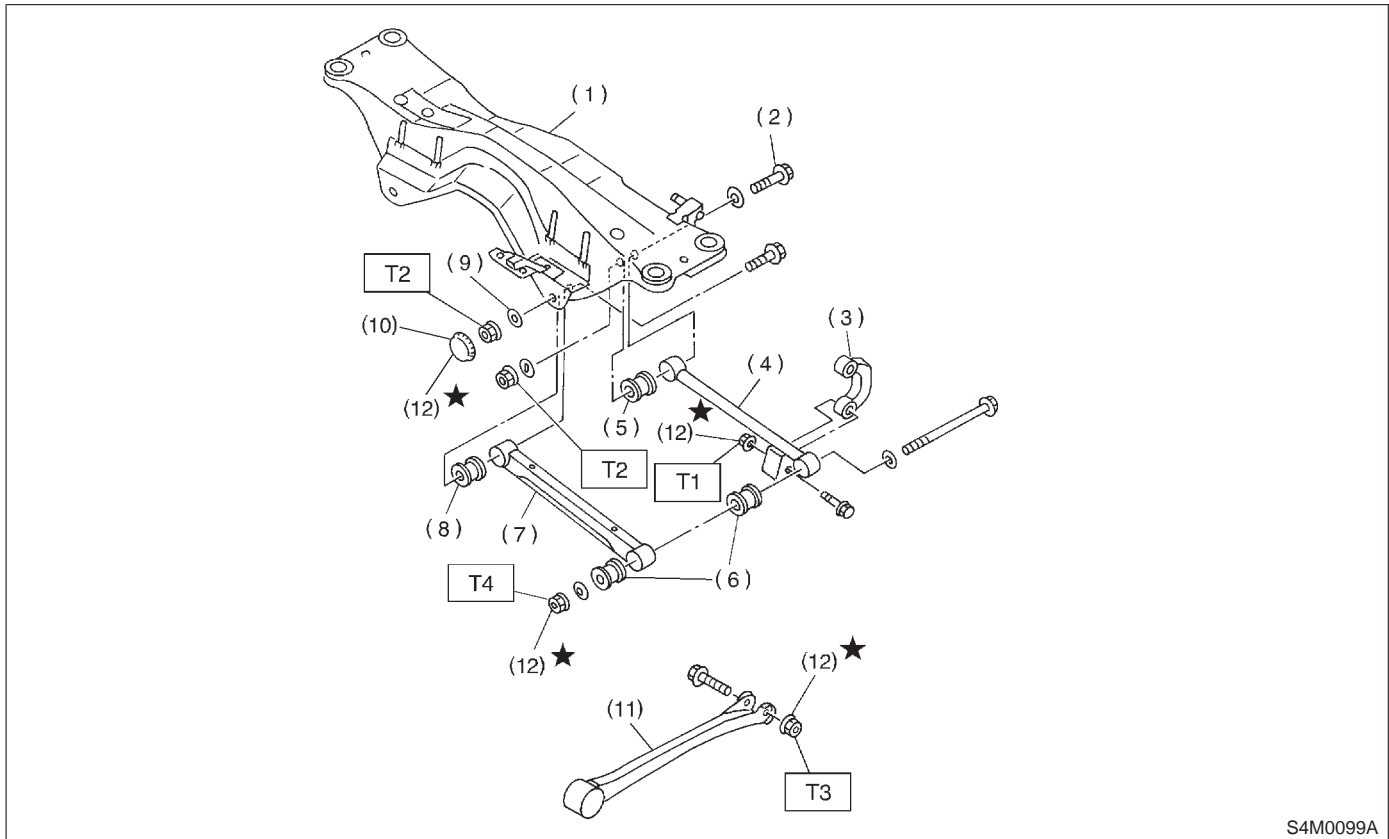

S4M0099A

- |                        |                       |
|------------------------|-----------------------|
| (1) Crossmember        | (8) Bushing (B)       |
| (2) Adjusting bolt     | (9) Washer            |
| (3) Stabilizer link    | (10) Cap (Protection) |
| (4) Rear lateral link  | (11) Trailing link    |
| (5) Bushing (C)        | (12) Self-locking nut |
| (6) Bushing (A)        |                       |
| (7) Front lateral link |                       |

**Tightening torque: N·m (kg·m, ft·lb)**

**T1: 44±6 (4.5±0.6, 32.5±4.3)**

**T2: 98±15 (10.0±1.5, 72±11)**

**T3: 113±15 (11.5±1.5, 83±11)**

**T4: 137±20 (14.0±2.0, 101±14)**

- 1) Loosen wheel nuts. Jack-up vehicle and remove wheel.
- 2) Remove stabilizers.
- 3) Remove ABS sensor harness from trailing link.

- 4) Remove bolt securing trailing link to housing.

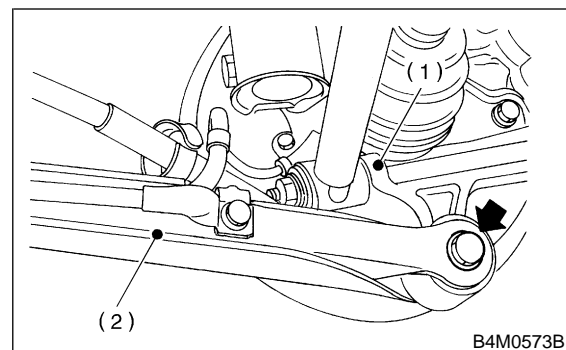

B4M0573B

- (1) Rear housing
- (2) Trailing link

- 5) Remove bolts which secure lateral link assembly to rear housing.

6) Remove DOJ from rear differential using ST.  
ST 28099PA100 DRIVE SHAFT REMOVER

**NOTE:**

The side spline shaft circlip comes out together with the shaft.

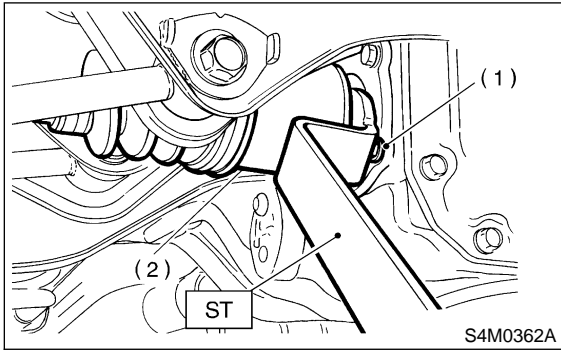

- (1) Bolt
- (2) DOJ

**CAUTION:**

Be careful not to damage side bearing retainer. Always use bolt as shown in figure, as supporting point for ST during removal.

7) Scribe an alignment mark on rear lateral link adjusting bolt and crossmember.

8) Remove bolts securing front and rear lateral links to crossmember, detach lateral links.

**CAUTION:**

To loosen adjusting bolt, always loosen nut while holding the head of adjusting bolt.

**B: DISASSEMBLY**

Using ST, press bushing out of place.

**NOTE:**

- Using the following table as a guide, verify the type of bushings.
- Select ST according to the type of bushings used.

Bushing	ST: INSTALLER & REMOVER SET
Bushing A	927700000
Bushing B	927690000
Bushing C	927700000

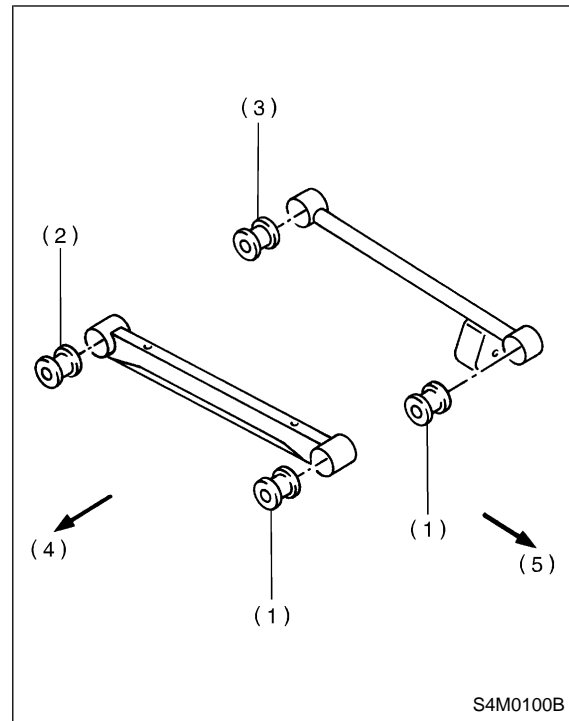

- (1) Bushing A
- (2) Bushing B
- (3) Bushing C
- (4) Front
- (5) Outside of body

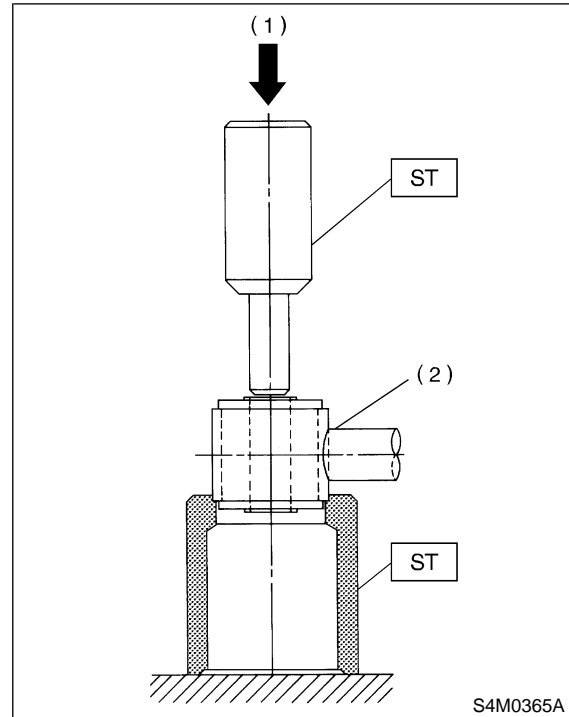

- (1) Press
- (2) Lateral link

**C: INSPECTION**

Visually check lateral links for damage or bends.

**D: ASSEMBLY**

1) Using ST, press bushing into place.

**CAUTION:**

Select ST according to the type of bushings used.

**NOTE:**

- Use the same ST as that used during disassembly.
- If it is difficult to press bushing into trailing link, apply water-diluted TIRE LUBE to the inner surface of ST as a lubricant.

**Specified lubricant:**

**TIRE LUBE : water = 1 : 3**

2) Press ST plunger until bushing flange protrudes beyond lateral link.

**NOTE:**

Use the same ST as that used during disassembly.

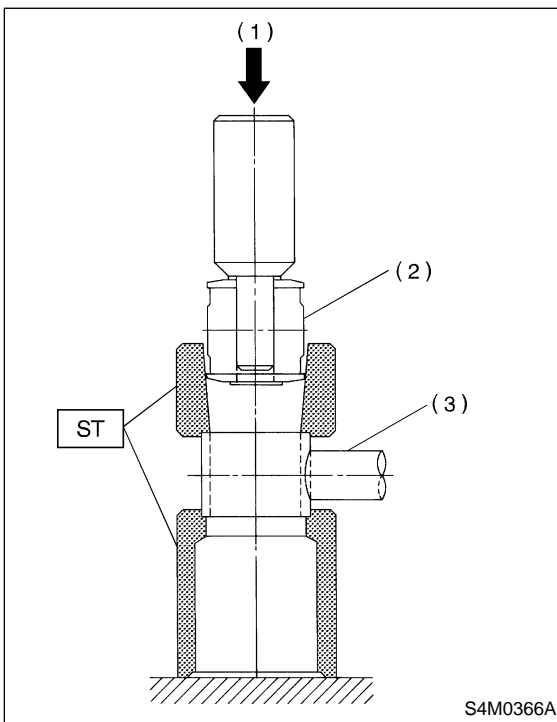

- (1) Press
- (2) Bushing
- (3) Lateral link

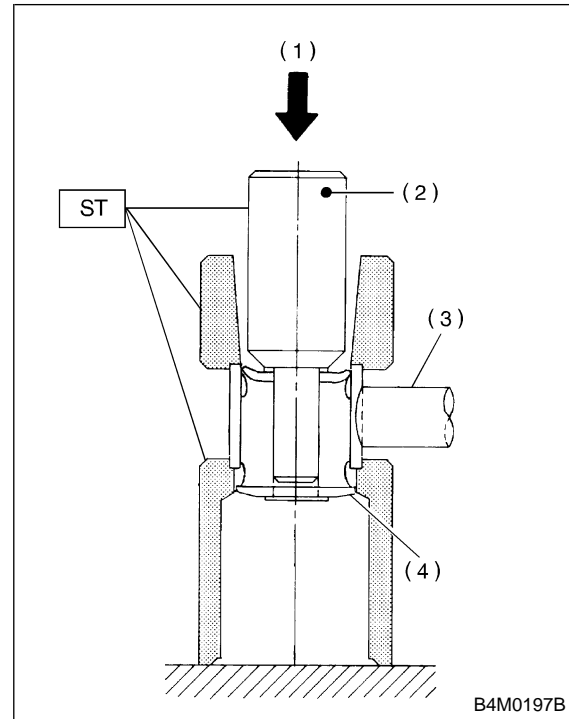

- (1) Press
- (2) Plunger
- (3) Lateral link
- (4) Flange



3) Turn lateral link upside down. Press ST plunger in the direction opposite that outlined in the former procedure until bushing is correctly positioned in trailing link.

NOTE:  
Use the same ST as that used during disassembly.

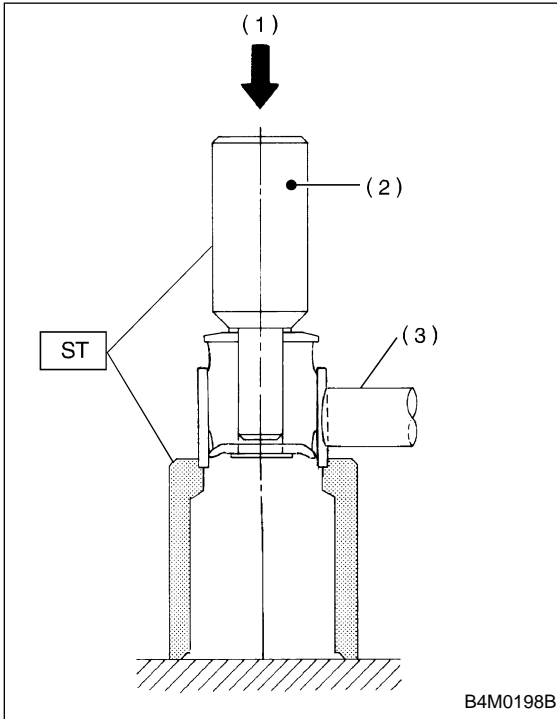

- (1) Press
- (2) Plunger
- (3) Lateral link

## E: INSTALLATION

Install in the reverse order of removal, observing the following instructions.

NOTE:  
Installation of DOJ to differential; <Ref. to 4-2 [W3E2].>

### CAUTION:

- Always tighten rubber bushing when wheels are in full contact with the ground and vehicle is curb weight.
- Tighten nut when installing adjusting bolt.
- Replace self-locking nut.

NOTE:  
Check wheel alignment and adjust if necessary.

## 9. Rear Strut

### A: REMOVAL

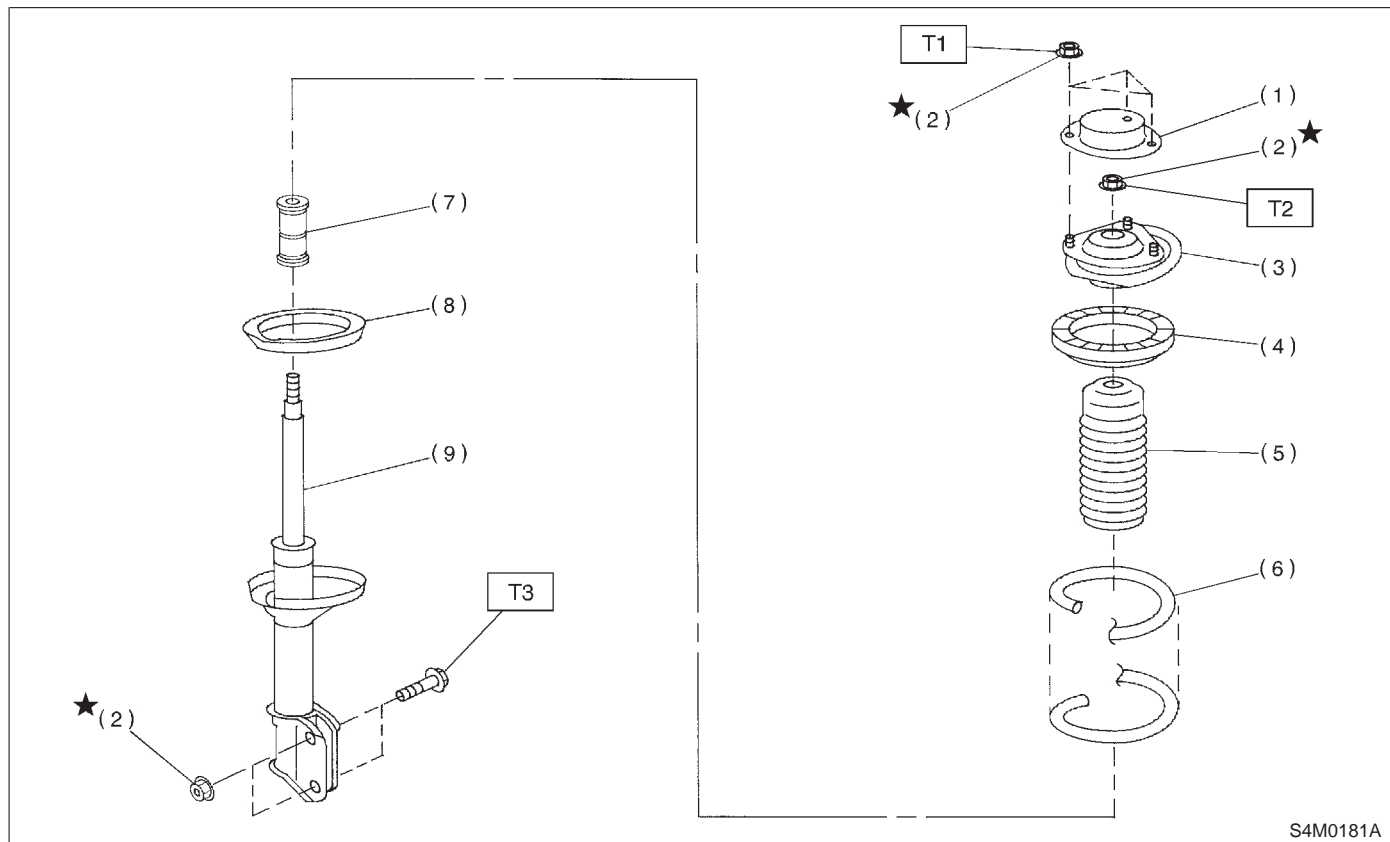

S4M0181A

- |                       |                       |
|-----------------------|-----------------------|
| (1) Strut mount cap   | (7) Helper            |
| (2) Self-locking nut  | (8) Rubber seat lower |
| (3) Strut mount       | (9) Damper strut      |
| (4) Rubber seat upper |                       |
| (5) Dust cover        |                       |
| (6) Coil spring       |                       |

**Tightening torque: N·m (kg·m, ft·lb)**

**T1: 20±6 (2.0±0.6, 14.5±4.3)**

**T2: 59±10 (6.0±1.0, 43±7)**

**T3: 196<sup>+39</sup>/<sub>-10</sub> (20.0<sup>+4.0</sup>/<sub>-1.0</sub>, 145<sup>+29</sup>/<sub>-7</sub>)**

- 1) Depress brake pedal and secure it in that position using a wooden block, etc.
- 2) Remove strut cap of rear quarter trim.

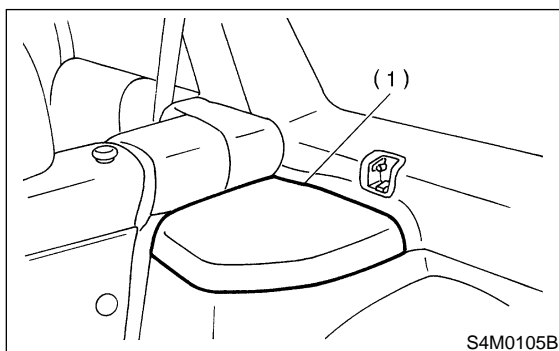

S4M0105B

(1) Strut cap

- 5) Remove brake hose clip.
- 6) Models equipped with rear disc brakes: Remove union bolt from brake caliper.

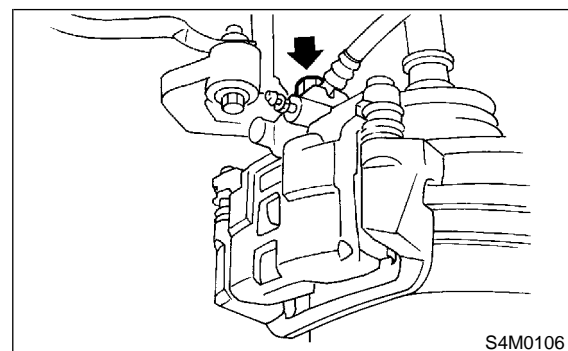

S4M0106

- 3) Loosen rear wheel nuts.
- 4) Jack-up vehicle, support it with safety stands (rigid racks) and remove rear wheels.

- 7) Models equipped with rear drum brakes: Disconnect brake hose from brake pipe from strut, and disconnect brake pipe from drum brake.

8) Use a garage jack to support the rear housing.

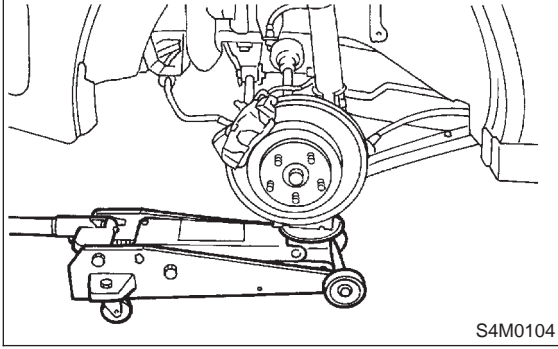

9) Remove nuts securing strut mount to body.

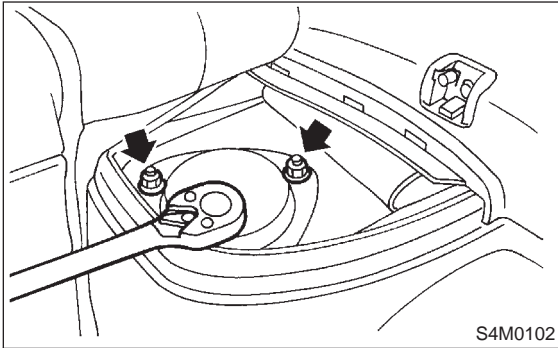

10) Remove bolts which secure rear strut to housing.

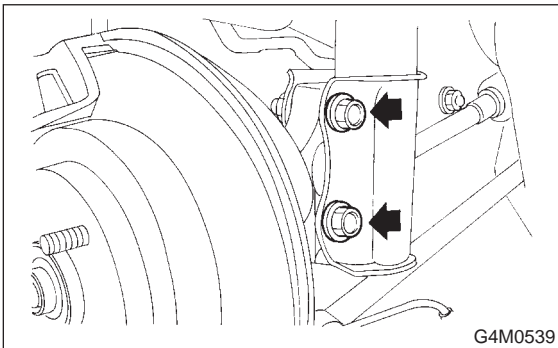

11) Remove strut mount.

## B: DISASSEMBLY

For disassembly of rear strut, refer to procedures outlined under Front Strut as a guide. <Ref. to 4-1 [W4B0].>

## C: INSPECTION

Refer to Front Strut as a guide for inspection procedures. <Ref. to 4-1 [W4C0].>

## D: ASSEMBLY

Refer to Front Strut as a guide for assembly procedures. <Ref. to 4-1 [W4D0].>

### CAUTION:

- Install rear strut with “4WD” mark on strut mount facing outside of vehicle body.
- Insert the protrusion of lower rubber seat into the strut spring seat hole.

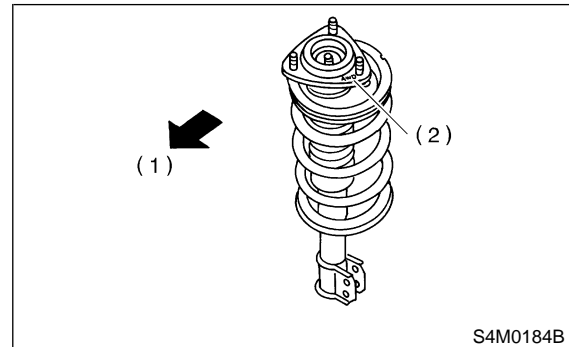

- (1) Front of vehicle  
(2) “4WD” mark

**E: INSTALLATION**

- 1) Install strut mount cap.
- 2) Tighten self-locking nut used to secure strut mount to vehicle body.

**CAUTION:**

**Use a new self-locking nut.**

**NOTE:**

Tighten strut mount and cap as a unit.

**Tightening torque:**

**$20 \pm 6$  N·m ( $2.0 \pm 0.6$  kg·m,  $14.5 \pm 4.3$  ft·lb)**

- 3) Tighten bolts securing rear strut to housing.

**Tightening torque:**

**$196^{+39}_{-10}$  N·m ( $20.0^{+4.0}_{-1.0}$  kg·m,  
 $145^{+29}_{-7}$  ft·lb)**

**CAUTION:**

**Use a new self-locking nut.**

- 4) Models with rear disc brakes:  
Tighten brake hose union bolt on brake caliper.

**Tightening torque:**

**$18 \pm 3$  N·m ( $1.8 \pm 0.3$  kg·m,  $13.0 \pm 2.2$  ft·lb)**

Models with rear drum brakes:  
Connect brake hose to brake pipe.

**Tightening torque:**

**$15^{+3}_{-2}$  N·m ( $1.5^{+0.3}_{-0.2}$  kg·m,  $10.8^{+2.2}_{-1.4}$   
ft·lb)**

- 5) Insert brake hose clip between brake hose and lower side of strut.

**CAUTION:**

- Check that hose clip is positioned properly.
- Check brake hose for twisting, or excessive tension.
- Do not subject ABS sensor harness to excessive tension.

- 6) Be sure to bleed air from brake system.
- 7) Lower vehicle and tighten wheel nut.

**Tightening torque:**

**$88 \pm 10$  N·m ( $9 \pm 1$  kg·m,  $65 \pm 7$  ft·lb)**

- 8) Install strut cap of rear quarter trim.

**NOTE:**

Check wheel alignment and adjust if necessary.

## 10. Rear Crossmember

## A: REMOVAL

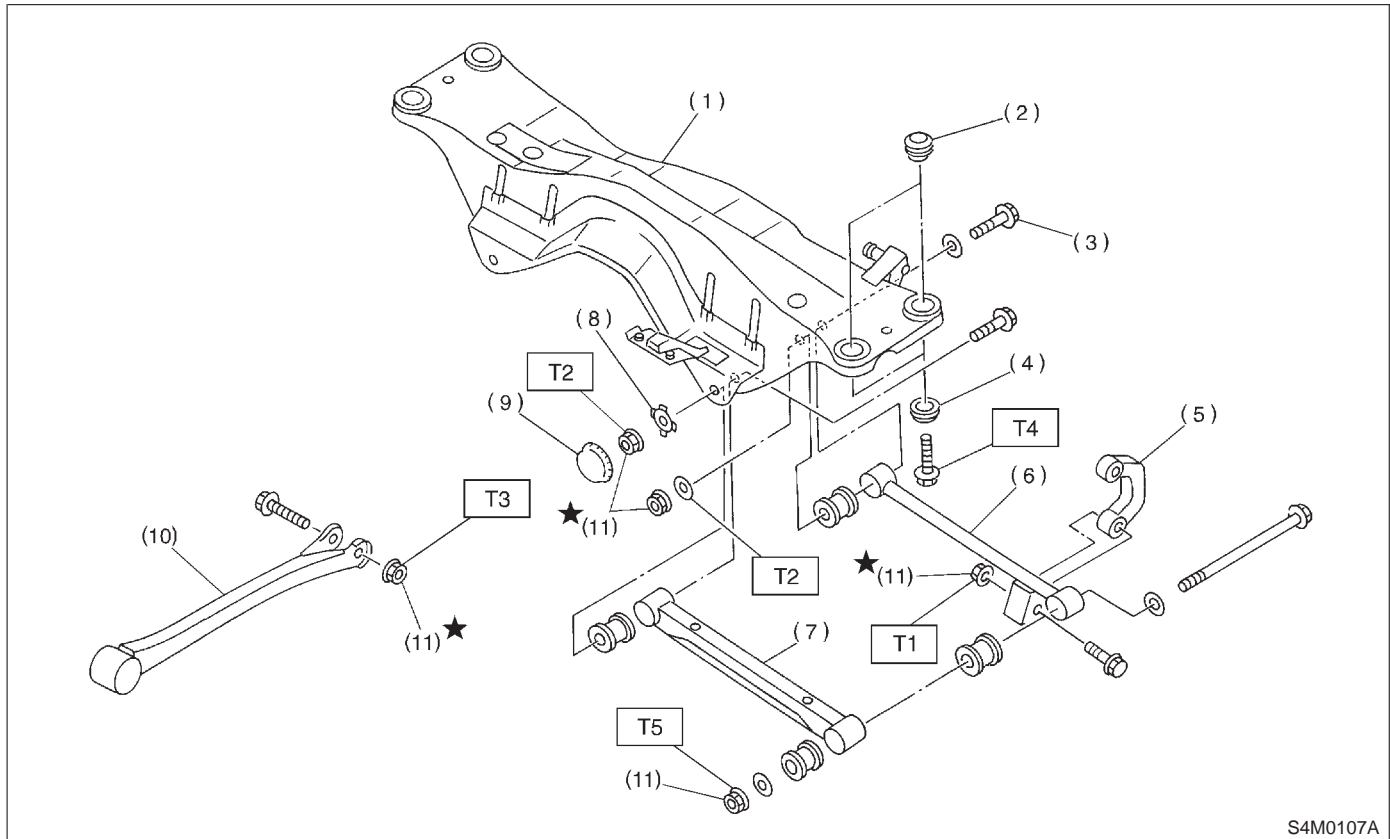

- |                        |                       |
|------------------------|-----------------------|
| (1) Crossmember        | (8) Washer            |
| (2) Floating bushing   | (9) Cap (Protection)  |
| (3) Adjusting bolt     | (10) Trailing link    |
| (4) Stopper            | (11) Self-locking nut |
| (5) Stabilizer link    |                       |
| (6) Rear lateral link  |                       |
| (7) Front lateral link |                       |

**Tightening torque: N·m (kg·m, ft·lb)**

**T1: 44±6 (4.5±0.6, 32.5±4.3)**

**T2: 98±15 (10.0±1.5, 72±11)**

**T3: 113±15 (11.5±1.5, 83±11)**

**T4: 127±20 (13.0±2.0, 94±14)**

**T5: 137±20 (14.0±2.0, 101±14)**

**CAUTION:**

**Do not subject ABS sensor harness to excessive tension.**

- 1) Separate front exhaust pipe and rear exhaust pipe.
- 2) Remove rear exhaust pipe and muffler.
- 3) Remove rear differential. <Ref. to 3-4 [W2B0].> or <Ref. to 3-4 [W3B0].>

- 4) Place transmission jack under rear crossmember.

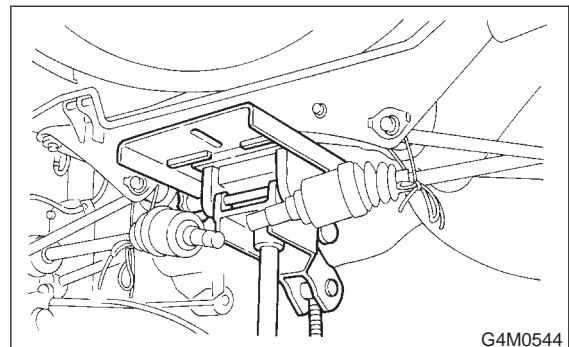

- 5) Remove bolts securing crossmember to vehicle body, and remove crossmember.

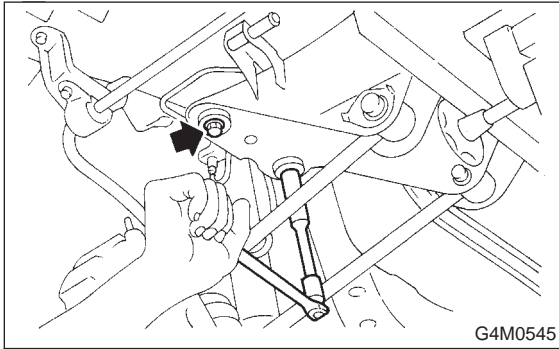

- 6) Scribe an alignment mark on rear lateral link cam bolt and crossmember.  
7) Remove front and rear lateral links by loosening nuts.

## B: INSPECTION

Check removed parts for wear, damage and cracks, and correct or replace if defective.

## C: INSTALLATION

- 1) Install in the reverse order of removal.
- 2) For installation and tightening torque of rear differential; <Ref. to 3-4 [W2F0].> or <Ref. to 3-4 [W3F0].>
- 3) Always tighten rubber bushing when wheels are in full contact with the ground and vehicle is curb weight.

### NOTE:

Check wheel alignment and adjust if necessary.

## 11. Rear Stabilizer

### A: REMOVAL

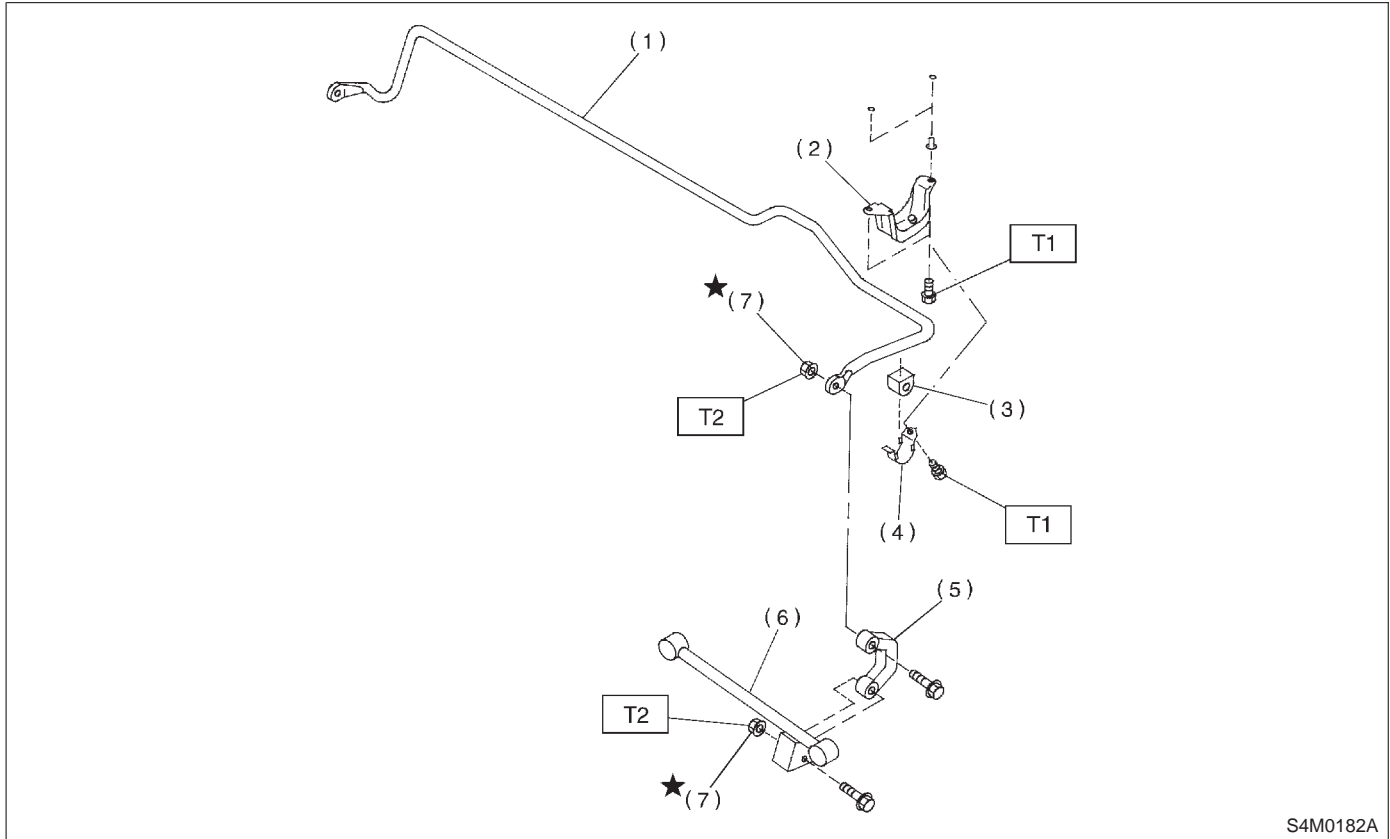

S4M0182A

- |                        |                       |
|------------------------|-----------------------|
| (1) Rear stabilizer    | (5) Stabilizer link   |
| (2) Stabilizer bracket | (6) Rear lateral link |
| (3) Stabilizer bushing | (7) Self-locking nut  |
| (4) Clamp              |                       |

**Tightening torque: N-m (kg-m, ft-lb)**

**T1: 25±7 (2.5±0.7, 18.1±5.1)**

**T2: 44±6 (4.5±0.6, 32.5±4.3)**

- 1) Jack-up the rear part of the vehicle, support it with safety stands (rigid racks).
- 2) Remove bolts which secure stabilizer link to rear lateral link.
- 3) Remove bolts which secure stabilizer to stabilizer bracket.

### B: INSPECTION

- 1) Check bushing for cracks, fatigue or damage.
- 2) Check stabilizer links for deformities, cracks, or damage, and bushing for protrusions from the hole of stabilizer link.

**C: INSTALLATION**

1) Install in the reverse order of removal.

**NOTE:**

- Install bushing while aligning it with paint mark on stabilizer.
- Ensure that bushing and stabilizer have the same identification colors when installing.

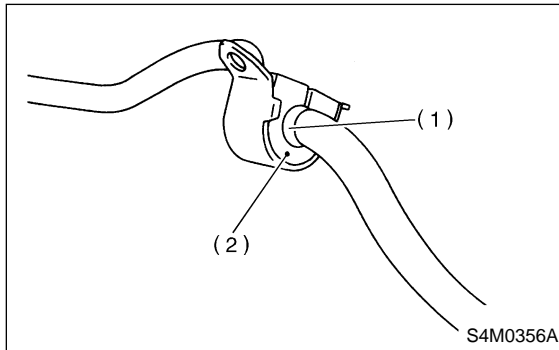

- (1) Mark stamped on stabilizer  
(2) Bushing identification color

2) Always tighten rubber bushing location when wheels are in full contact with the ground and vehicle is curb weight.

3) The tightening torque is as follows.

**Stabilizer link to rear lateral link:**

**$44\pm 6$  N-m ( $4.5\pm 0.6$  kg-m,  $32.5\pm 4.3$  ft-lb)**

**Stabilizer to stabilizer bracket:**

**$25\pm 7$  N-m ( $2.5\pm 0.7$  kg-m,  $18.1\pm 5.1$  ft-lb)**



## 1. Suspension

### A: IMPROPER VEHICLE POSTURE OR IMPROPER WHEEL ARCH HEIGHT

Possible causes	Countermeasures
(1) Permanent distortion or breakage of coil spring	Replace.
(2) Unsmooth operation of damper strut	Replace.
(3) Installation of wrong strut	Replace with proper parts.
(4) Installation of wrong coil spring	Replace with proper parts.

### B: POOR RIDE COMFORT

- 1) Large rebound shock
- 2) Rocking of vehicle continues too long after running over bump and/or hump.
- 3) Large shock in bumping

Possible causes	Countermeasures
(1) Breakage of coil spring	Replace.
(2) Overinflation pressure of tire	Adjust.
(3) Improper wheel arch height	Adjust or replace coil springs with new ones.
(4) Fault in operation of damper strut	Replace.
(5) Damage or deformation of strut mount	Replace.
(6) Unsuitability of maximum and/or minimum length of damper strut	Replace with proper parts.
(7) Deformation or loss of bushing	Replace.
(8) Deformation or damage of helper in strut assembly	Replace.
(9) Oil leakage of damper strut	Replace.

### C: NOISE

Possible causes	Countermeasures
(1) Wear or damage of damper strut component parts	Replace.
(2) Loosening of suspension link installing bolt	Retighten to the specified torque.
(3) Deformation or loss of bushing	Replace.
(4) Unsuitability of maximum and/or minimum length of damper strut	Replace with proper parts.
(5) Breakage of coil spring	Replace.
(6) Wear or damage of ball joint	Replace.
(7) Deformation of stabilizer clamp	Replace.

1. Tire and Wheel Size

**1. Tire and Wheel Size**

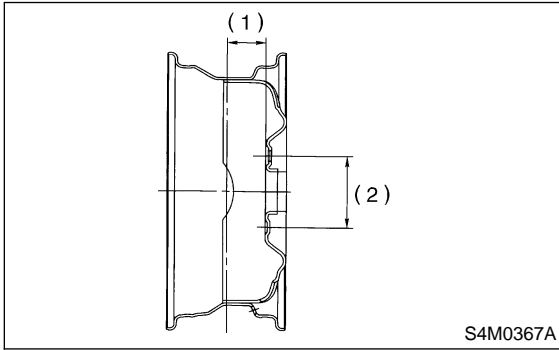

- (1) Offset
- (2) P.C.D.

		Tire size	Rim size	Rim offset	P.C.D.
Front and Rear	L	P205/70R15 95S	15 × 6J	48 mm (1.89 in)	100 mm (3.94 in) dia.
	S	P215/60R16 94H	16 × 6 1/2JJ	48 mm (1.89 in)	

NOTE:  
Spare tires are the same for both front and rear.

**2. Tire Inflation Pressure**

Model	Tire size	Tire inflation pressure	
		Light load	Full load
L	P205/70R15 95S	Ft: 200 kPa (2.0 kg/cm <sup>2</sup> , 29 psi)	Ft: 200 kPa (2.0 kg/cm <sup>2</sup> , 29 psi)
S	P215/60R16 94H	Rr: 190 kPa (1.9 kg/cm <sup>2</sup> , 27 psi)	Rr: 250 kPa (2.5 kg/cm <sup>2</sup> , 36 psi)

NOTE:  
At trailer towing, rear inflation pressure is 280 kPa (2.8 kg/cm<sup>2</sup>, 41 psi).

1. Tire and Wheel Size

**1. Tire and Wheel Size**

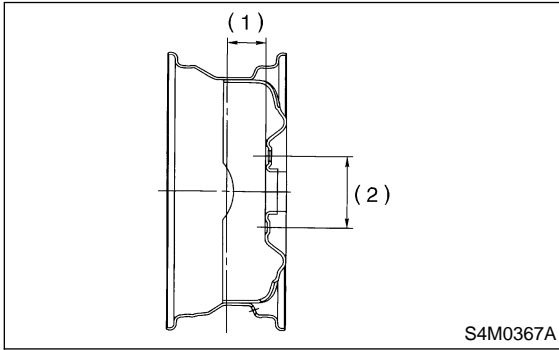

- (1) Offset
- (2) P.C.D.

		Tire size	Rim size	Rim offset	P.C.D.
Front and Rear	L	P205/70R15 95S	15 × 6J	48 mm (1.89 in)	100 mm (3.94 in) dia.
	S	P215/60R16 94H	16 × 6 1/2JJ	48 mm (1.89 in)	

NOTE:  
Spare tires are the same for both front and rear.

**2. Tire Inflation Pressure**

Model	Tire size	Tire inflation pressure	
		Light load	Full load
L	P205/70R15 95S	Ft: 200 kPa (2.0 kg/cm <sup>2</sup> , 29 psi)	Ft: 200 kPa (2.0 kg/cm <sup>2</sup> , 29 psi)
S	P215/60R16 94H	Rr: 190 kPa (1.9 kg/cm <sup>2</sup> , 27 psi)	Rr: 250 kPa (2.5 kg/cm <sup>2</sup> , 36 psi)

NOTE:  
At trailer towing, rear inflation pressure is 280 kPa (2.8 kg/cm<sup>2</sup>, 41 psi).

### 3. Front Drive Shaft Assembly

Type of drive shaft assembly	SHAFT
	Shaft diameter
BJ87L+SFJ82	26 mm (1.02 in)

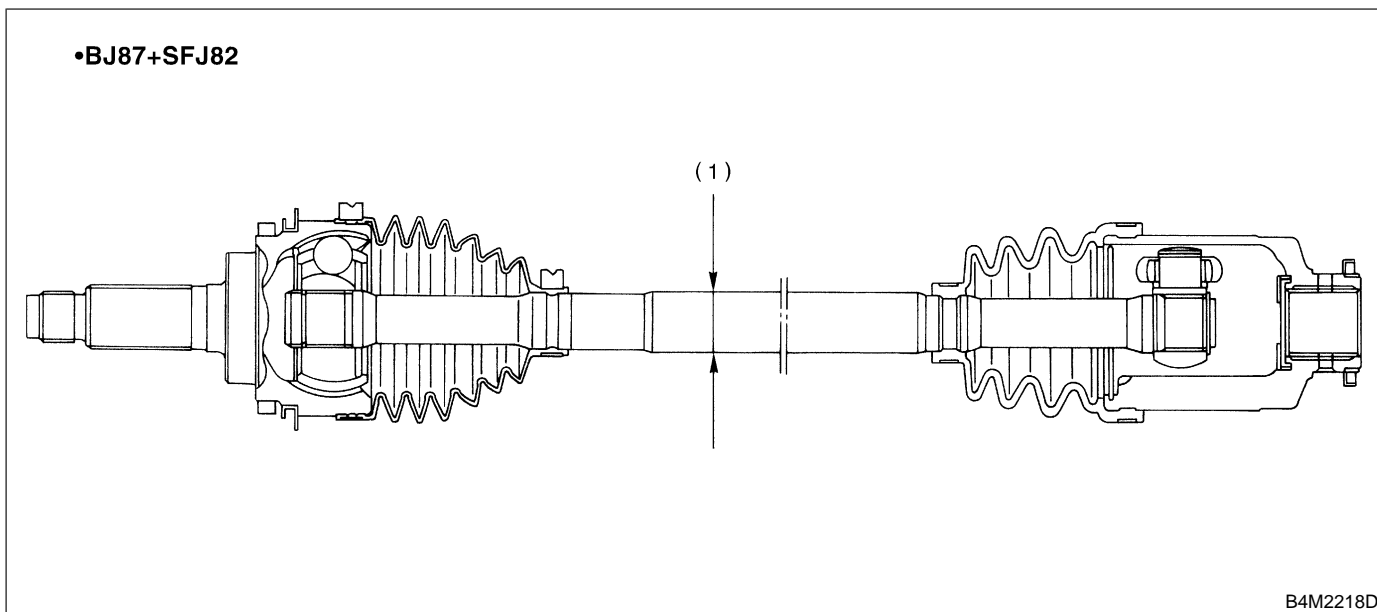

(1) Measuring point

### 4. Rear Drive Shaft Assembly

Type of drive shaft assembly	SHAFT		Boot band identification color
	No. of identification paddings on shaft	Shaft diameter	
79AC-RH	2 (Two)	23 mm (0.91 in)	Purple
79AC-LH	1 (One)	23 mm (0.91 in)	

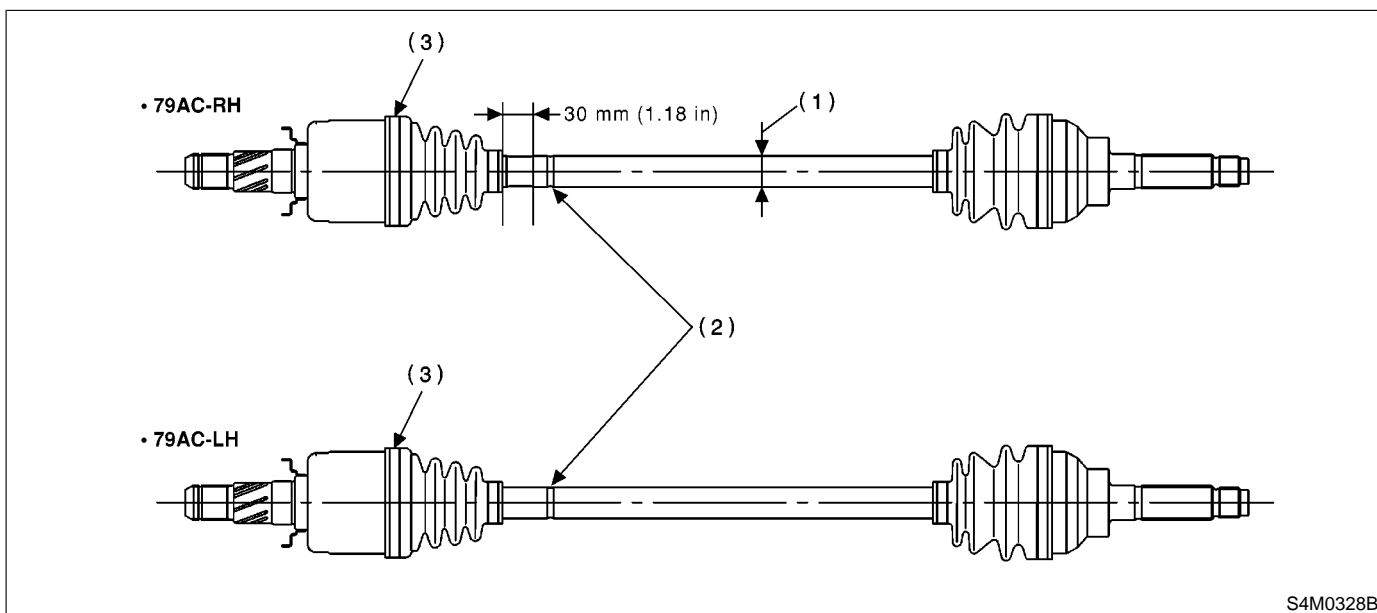

(1) Measuring point

(2) Identification padding

(3) Boot band identification

### 3. Front Drive Shaft Assembly

Type of drive shaft assembly	SHAFT
	Shaft diameter
BJ87L+SFJ82	26 mm (1.02 in)

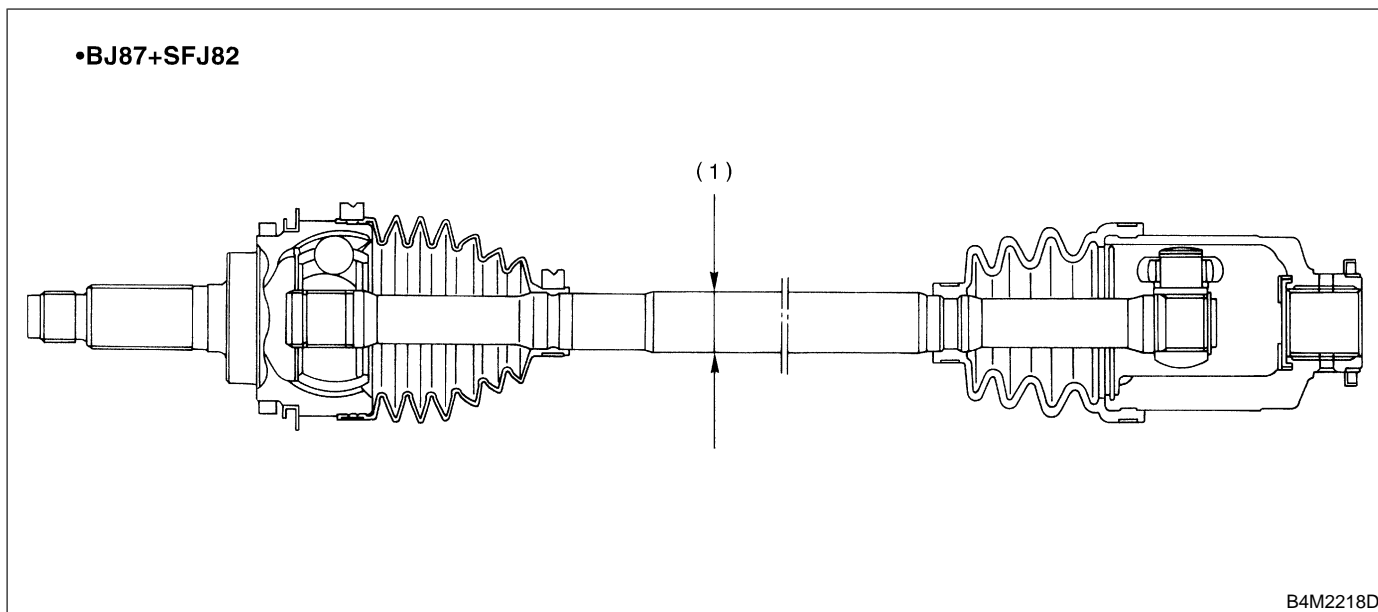

(1) Measuring point

### 4. Rear Drive Shaft Assembly

Type of drive shaft assembly	SHAFT		Boot band identification color
	No. of identification paddings on shaft	Shaft diameter	
79AC-RH	2 (Two)	23 mm (0.91 in)	Purple
79AC-LH	1 (One)	23 mm (0.91 in)	

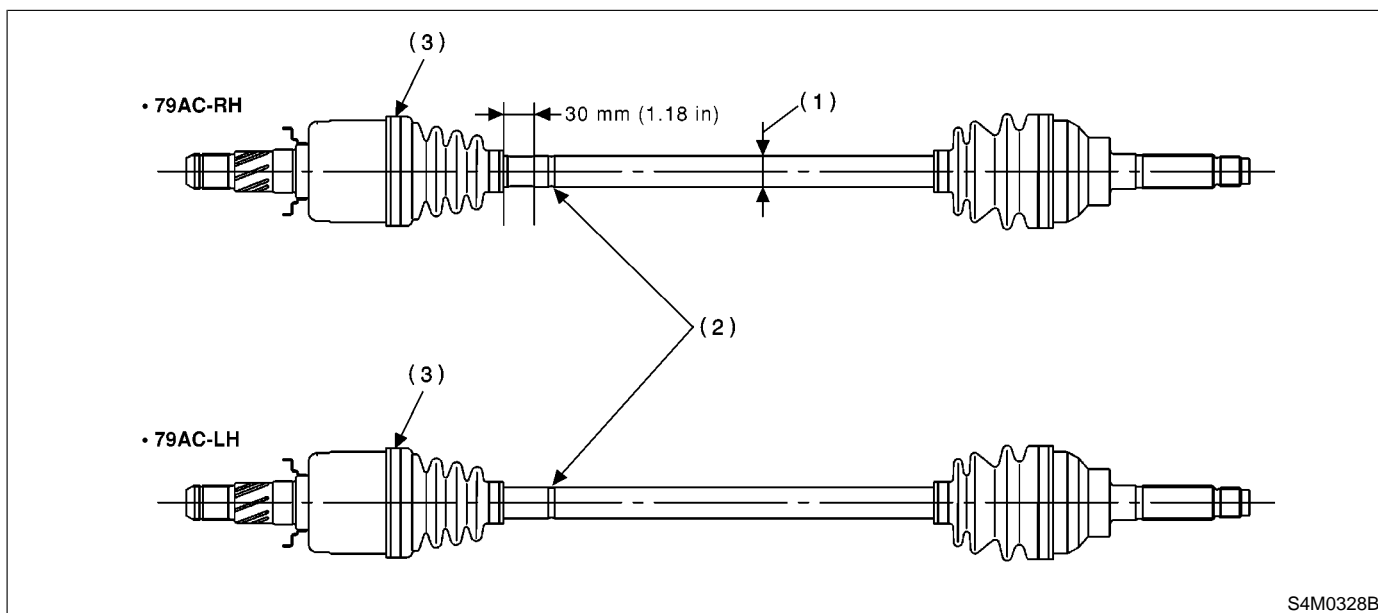

(1) Measuring point

(2) Identification padding

(3) Boot band identification

## 5. Application Table

Power unit	Front drive shaft	Rear drive shaft
2500 cc	BJ87L+SFJ82	79AC-RH, 79AC-LH

## 6. Wheel Balance

Wheel balancing	Standard	Service limit
Dynamic unbalance	Less than 5 g (0.18 oz)	

Balance weight part number (For steel wheel)	Weight
28101FC000	5 g (0.18 oz)
28101FC010	10 g (0.35 oz)
28101FC020	15 g (0.53 oz)
723141320	20 g (0.71 oz)
723141330	25 g (0.88 oz)
723141340	30 g (1.06 oz)
723141350	35 g (1.23 oz)
723141360	40 g (1.41 oz)
723141370	45 g (1.59 oz)
723141380	50 g (1.76 oz)
723141580	55 g (1.94 oz)
723141590	60 g (2.12 oz)

Balance weight part number (For aluminum wheel)	Weight
23141GA462	5 g (0.18 oz)
23141GA472	10 g (0.35 oz)
23141GA482	15 g (0.53 oz)
23141GA492	20 g (0.71 oz)
23141GA502	25 g (0.88 oz)
23141GA512	30 g (1.06 oz)
23141GA522	35 g (1.23 oz)
23141GA532	40 g (1.41 oz)
23141GA542	45 g (1.59 oz)
23141GA552	50 g (1.76 oz)
—	55 g (1.94 oz)
23141GA572	60 g (2.12 oz)

## 5. Application Table

Power unit	Front drive shaft	Rear drive shaft
2500 cc	BJ87L+SFJ82	79AC-RH, 79AC-LH

## 6. Wheel Balance

Wheel balancing	Standard	Service limit
Dynamic unbalance	Less than 5 g (0.18 oz)	

Balance weight part number (For steel wheel)	Weight
28101FC000	5 g (0.18 oz)
28101FC010	10 g (0.35 oz)
28101FC020	15 g (0.53 oz)
723141320	20 g (0.71 oz)
723141330	25 g (0.88 oz)
723141340	30 g (1.06 oz)
723141350	35 g (1.23 oz)
723141360	40 g (1.41 oz)
723141370	45 g (1.59 oz)
723141380	50 g (1.76 oz)
723141580	55 g (1.94 oz)
723141590	60 g (2.12 oz)

Balance weight part number (For aluminum wheel)	Weight
23141GA462	5 g (0.18 oz)
23141GA472	10 g (0.35 oz)
23141GA482	15 g (0.53 oz)
23141GA492	20 g (0.71 oz)
23141GA502	25 g (0.88 oz)
23141GA512	30 g (1.06 oz)
23141GA522	35 g (1.23 oz)
23141GA532	40 g (1.41 oz)
23141GA542	45 g (1.59 oz)
23141GA552	50 g (1.76 oz)
—	55 g (1.94 oz)
23141GA572	60 g (2.12 oz)

1. Front Axle

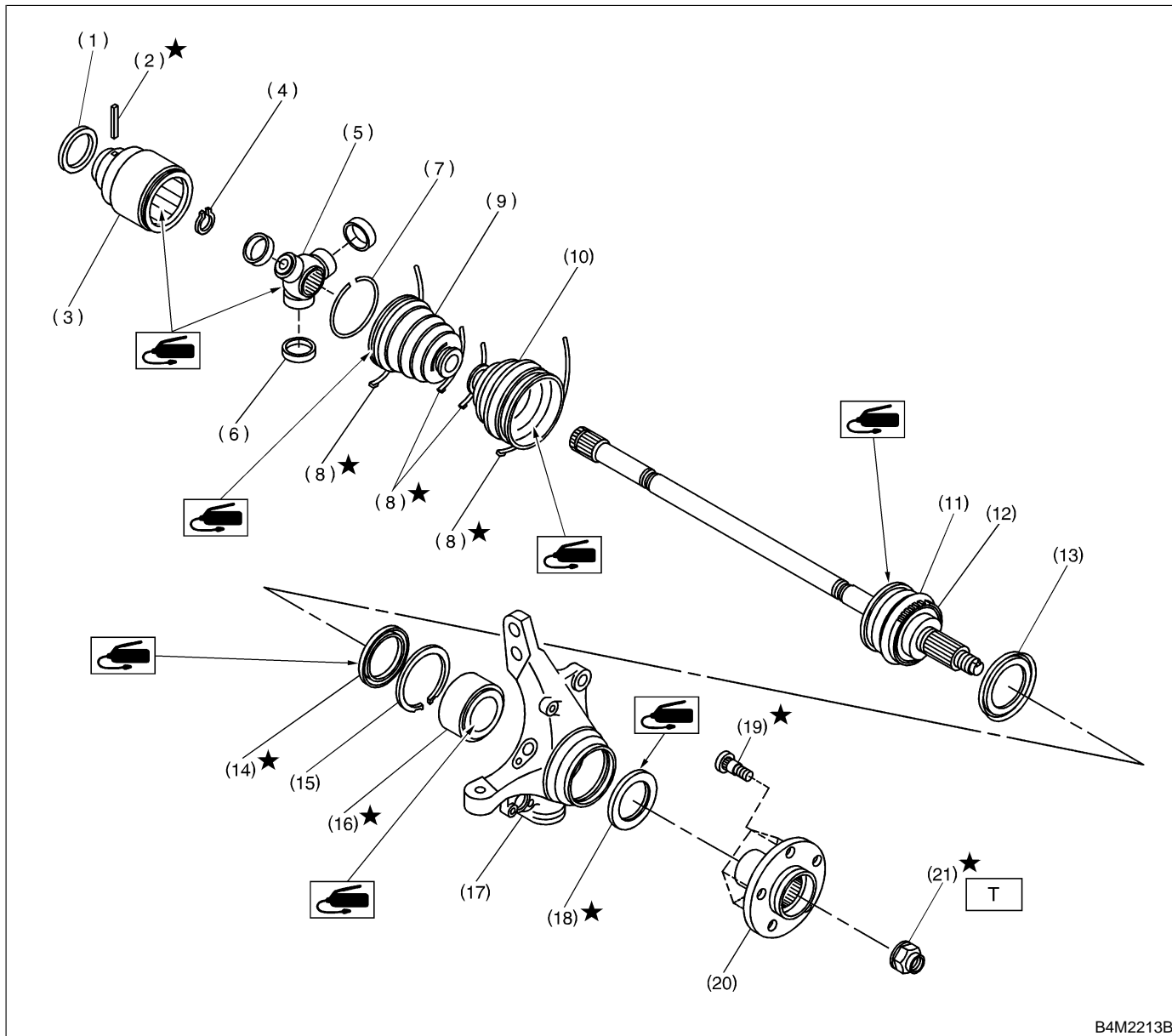

B4M2213B

- (1) Baffle plate (SFJ)
- (2) Spring pin
- (3) Outer race (SFJ)
- (4) Snap ring
- (5) Trunnion
- (6) Free ring
- (7) Circlip
- (8) Boot band
- (9) Boot (SFJ)

- (10) Boot (BJ)
- (11) BJ ASSY
- (12) Tone wheel
- (13) Baffle plate
- (14) Oil seal (IN)
- (15) Snap ring
- (16) Bearing
- (17) Housing
- (18) Oil seal (OUT)

- (19) Hub bolt
- (20) Hub
- (21) Axle nut

**Tightening torque: N·m (kg·m, ft·lb)**  
**T: 186±20 (19±2, 137±14)**



2. Rear Axle

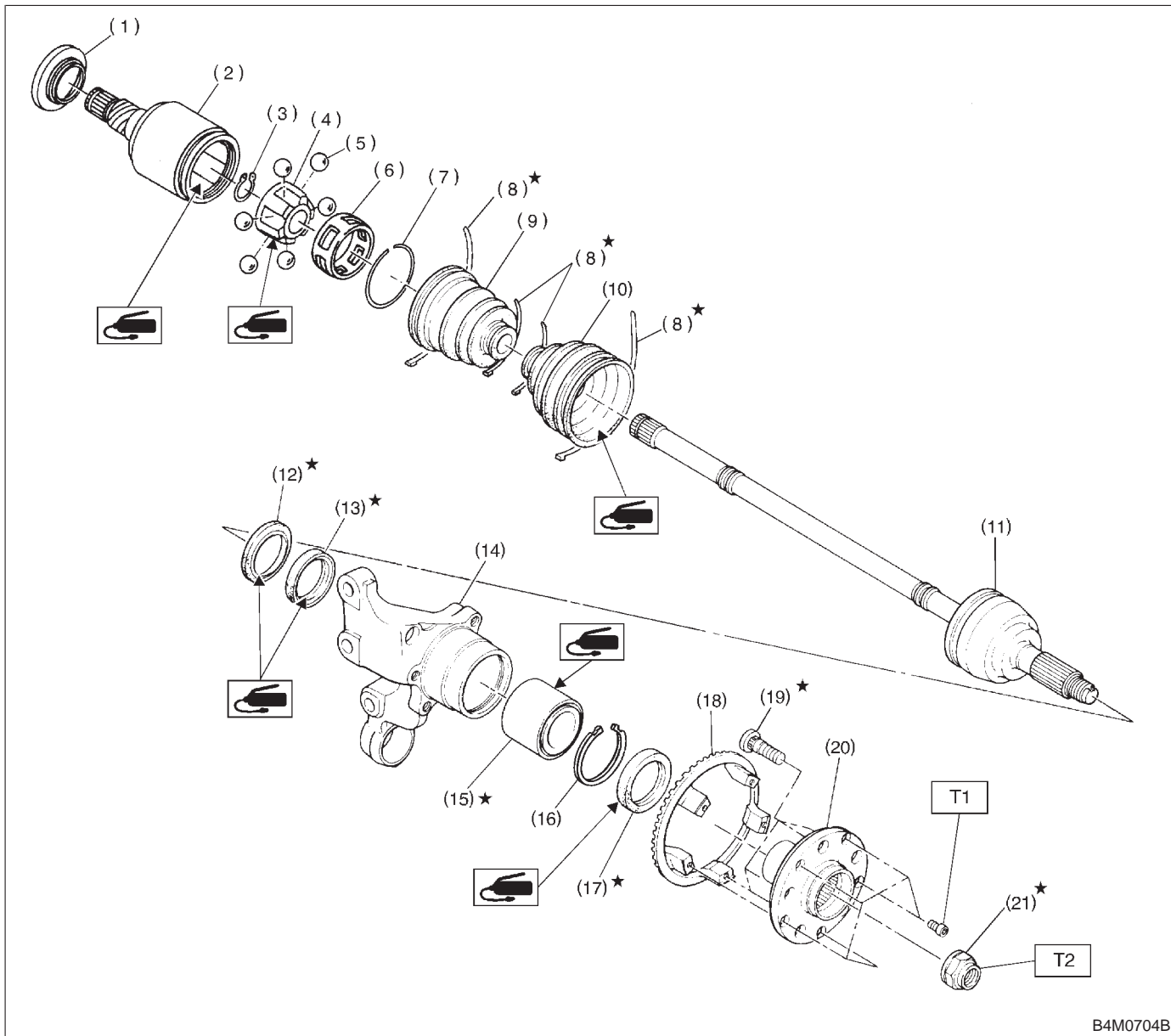

B4M0704B

- (1) Baffle plate (DOJ)
- (2) Outer race (DOJ)
- (3) Snap ring
- (4) Inner race
- (5) Ball
- (6) Cage
- (7) Circlip
- (8) Boot band
- (9) Boot (DOJ)

- (10) Boot (BJ)
- (11) BJ ASSY
- (12) Oil seal (IN. No. 2)
- (13) Oil seal (IN)
- (14) Housing
- (15) Bearing
- (16) Snap ring
- (17) Oil seal (OUT)
- (18) Tone wheel

- (19) Hub bolt
- (20) Hub
- (21) Axle nut

**Tightening torque: N-m (kg-m, ft-lb)**

**T1: 13±3 (1.3±0.3, 9.4±2.2)**

**T2: 186±20 (19±2, 137±14)**

# 1. Front Axle

## A: REMOVAL

- 1) Disconnect ground cable from battery.
- 2) Jack-up vehicle, support it with safety stands, and remove front wheels.
- 3) Unlock axle nut.

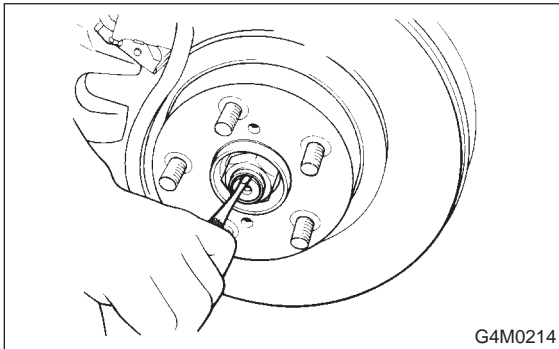

- 4) Remove axle nut using a socket wrench.

**CAUTION:**

Be sure to loose and retighten axle nut after removing wheel from vehicle. Failure to follow this rule may damage wheel bearings.

- 5) Remove stabilizer link.

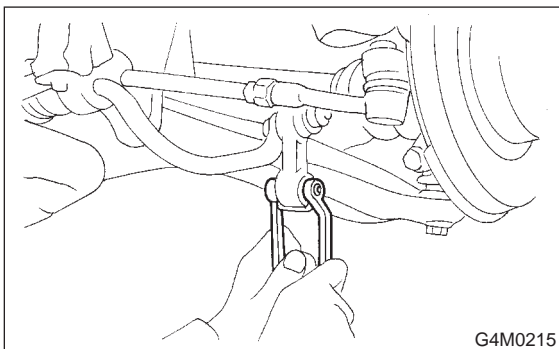

- 6) Remove disc brake caliper from housing, and suspend it from strut using a wire.

- 7) Remove front drive shaft assembly from hub. If it is hard to remove, use STs.

- ST1 926470000 AXLE SHAFT PULLER
- ST2 927140000 PLATE

**CAUTION:**

- Be careful not to damage oil seal lip when removing front drive shaft.
- When replacing front drive shaft, also replace inner oil seal.

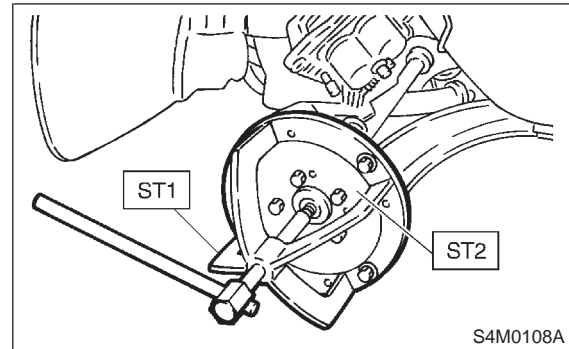

- 8) Remove disc rotor from hub. If disc rotor seizes up within hub, drive disc rotor out by installing an 8-mm bolt in screw hole on the rotor.

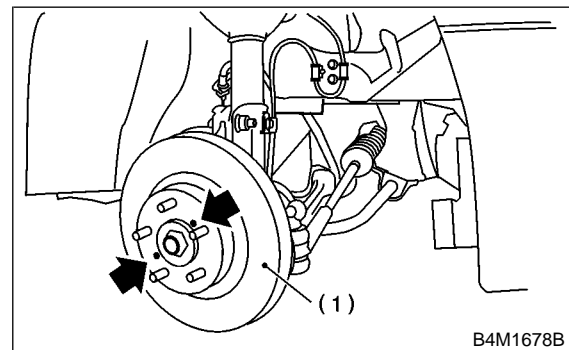

(1) Disc rotor

- 9) Remove cotter pin and castle nut which secure tie-rod end to housing knuckle arm.

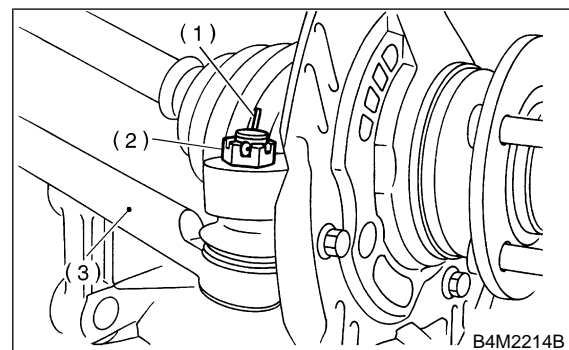

(1) Cotter pin  
 (2) Castle nut  
 (3) Tie-rod

10) Using a puller, remove tie-rod ball joint from knuckle arm.

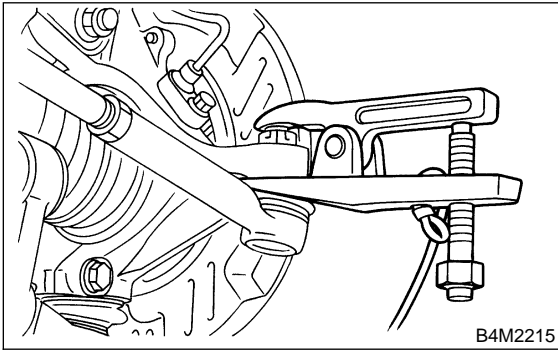

11) Remove ABS sensor assembly and harness in advance.

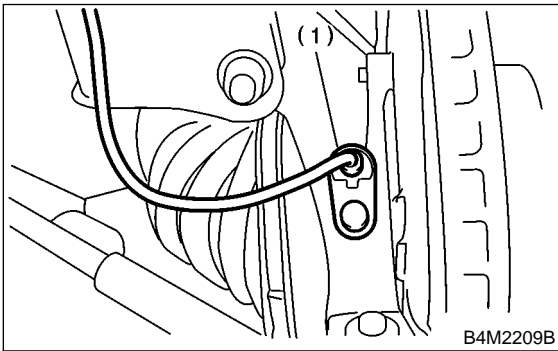

(1) Front ABS sensor

12) Remove bolt which secures sensor harness to strut.

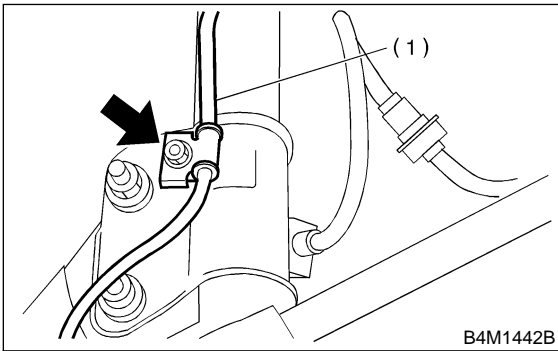

(1) Sensor harness

13) Remove transverse link ball joint from housing.

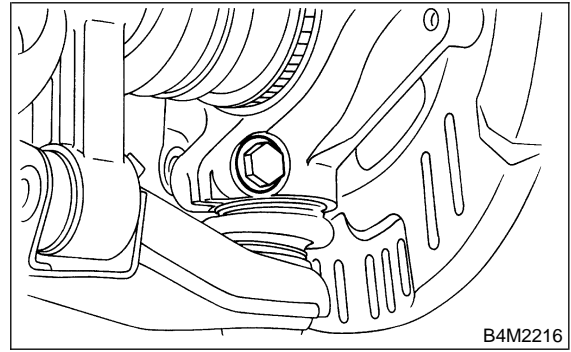

14) Remove SFJ from transmission spindle.  
 15) Remove front drive shaft assembly from hub. If it is hard to remove, use STs.

- ST1 926470000 AXLE SHAFT PULLER
- ST2 927140000 PLATE

**CAUTION:**

- Be careful not to damage oil seal lip and tone wheel when removing front drive shaft.
- When replacing front drive shaft, also replace inner oil seal.

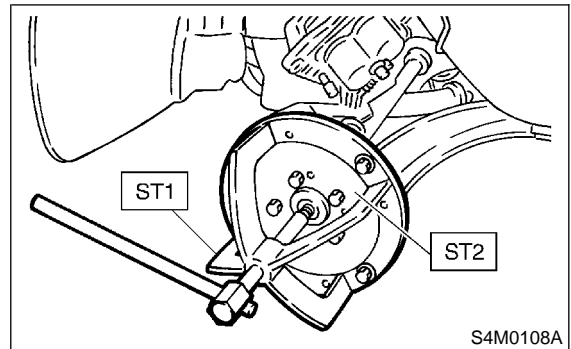

16) After scribing an alignment mark on camber adjusting bolt head, remove bolts which connect housing and strut, and disconnect housing from strut.

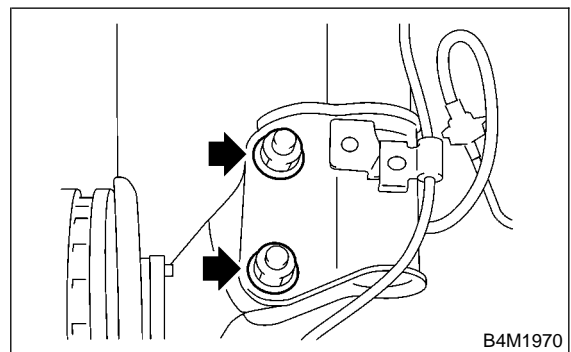

## B: DISASSEMBLY

- 1) Using ST1, support housing and hub securely.
- 2) Attach ST2 to housing and drive hub out.

ST1 927060000 HUB REMOVER  
 ST2 927080000 HUB STAND

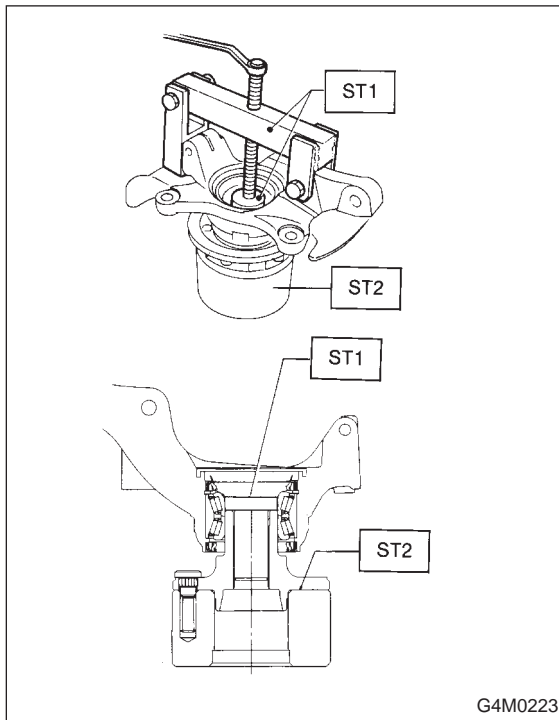

If inner bearing race remains in the hub, remove it with a suitable tool (commercially available).

**CAUTION:**

- Be careful not to scratch polished area of hub.
- Be sure to install inner race on the side of outer race from which it was removed.

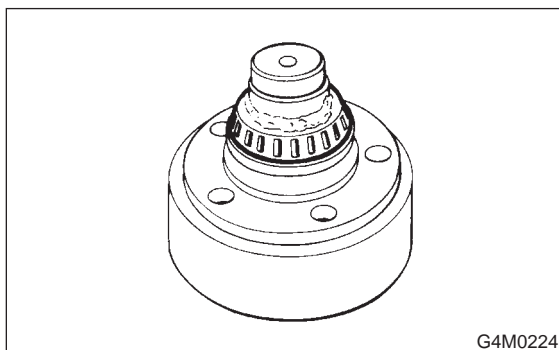

- 3) Remove disc cover from housing.

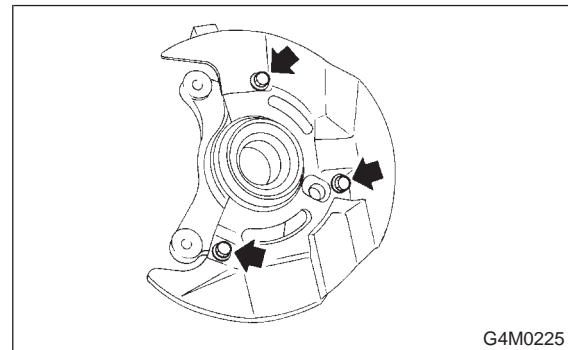

- 4) Using a standard screwdriver, remove outer and inner oil seals.

**CAUTION:**  
 Do not use old oil seals.

- 5) Using flat bladed screwdriver, remove snap ring.

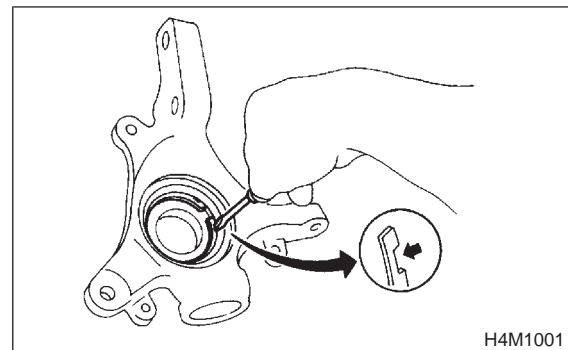

- 6) Using ST1, support housing securely.
- 7) Using ST2, press inner race to drive out outer bearing.

ST1 927400000 HOUSING STAND  
 ST2 927100000 BEARING REMOVER

**CAUTION:**

- Do not remove outer race unless it is faulty.
- Discard outer race after removal.
- Do not replace inner or outer race separately; always replace as a unit.

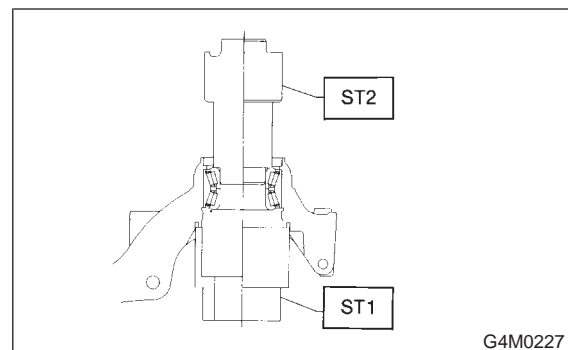

1. Front Axle

8) Using ST and a hydraulic press, drive hub bolts out.

ST 927080000 HUB STAND

**CAUTION:**

Be careful not to hammer hub bolts. This may deform hub.

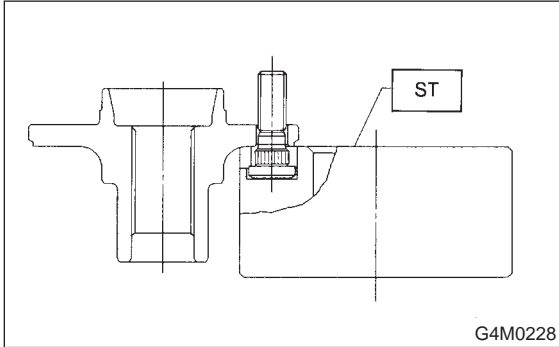

**C: INSPECTION**

Check the removed parts for wear and damage. If defective, replace with new ones.

**CAUTION:**

- If bearing is faulty, replace it as a bearing set.
- Be sure to replace oil seal at every overhaul.

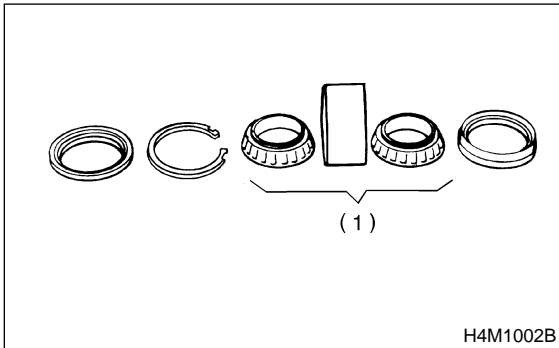

(1) Replace as a set.

**D: ASSEMBLY**

1) Securely attach hub to ST.

ST 927080000 HUB STAND

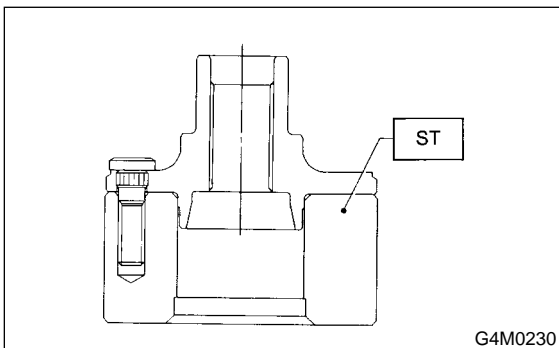

2) Using a hydraulic press, press new hub bolts into place.

**CAUTION:**

Be sure to press hub bolts until their seating surfaces contact the hub.

**NOTE:**

Use 12 mm (0.47 in) dia. holes in HUB STAND to prevent bolts from tilting.

3) Clean dust or foreign particles from inside the housing.

4) Using ST1 and ST2, press a new bearing into place.

ST1 927400000 HOUSING STAND

ST2 927100000 BEARING REMOVER

**CAUTION:**

- Always press outer race when installing bearing.
- Be careful not to remove plastic lock from inner race when installing bearing.
- Charge bearing with new grease when outer race is not removed.

**Specified grease:**

**SHELL 6459N**

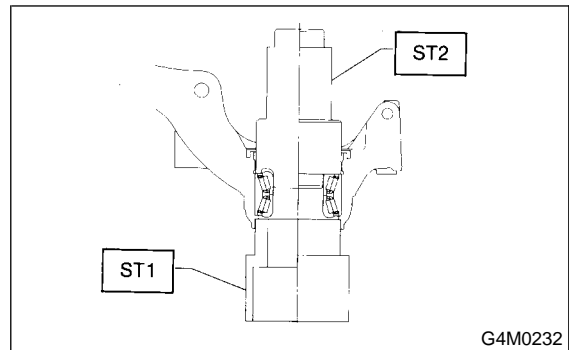

5) Using pliers, install snap ring in its groove.

**CAUTION:**

Make sure to install it firmly to groove.

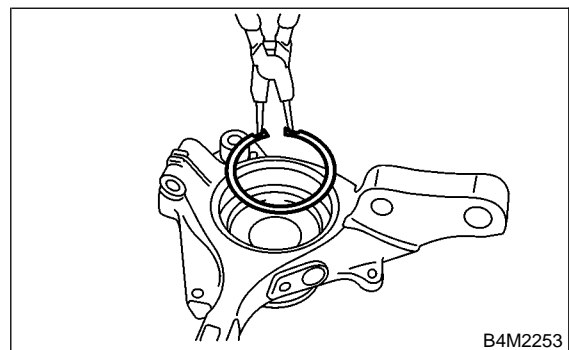

6) Using ST1 and ST2, press inner oil seal until it contacts circlip.

ST1 927410000 OIL SEAL INSTALLER  
ST2 927400000 HOUSING STAND

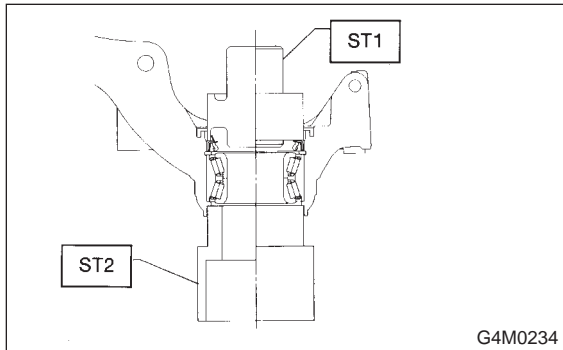

7) Invert ST and housing.

ST 927400000 HOUSING STAND

8) Using ST1 and ST2, press outer oil seal until it contacts the bottom of housing.

ST1 927410000 OIL SEAL INSTALLER  
ST2 927400000 HOUSING STAND

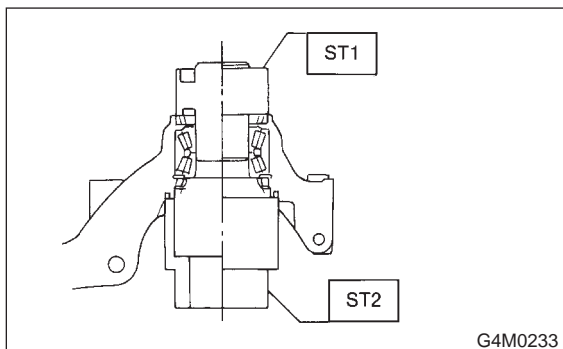

9) Apply sufficient grease to oil seal lip.

**Specified grease:**  
**SHELL 6459N**

**CAUTION:**

- If specified grease is not available, remove bearing grease and apply Auto Rex A instead.
- Do not mix different types of grease.

10) Install disc cover to housing and the three bolts.

**Tightening torque:**  
**18±5 N-m (1.8±0.5 kg-m, 13.0±3.6 ft-lb)**

11) Attach hub to ST1 securely.

12) Clean dust or foreign particles from the polished surface of hub.

13) Using ST2, press bearing into hub by driving inner race.

ST1 927080000 HUB STAND  
ST2 927120000 HUB INSTALLER

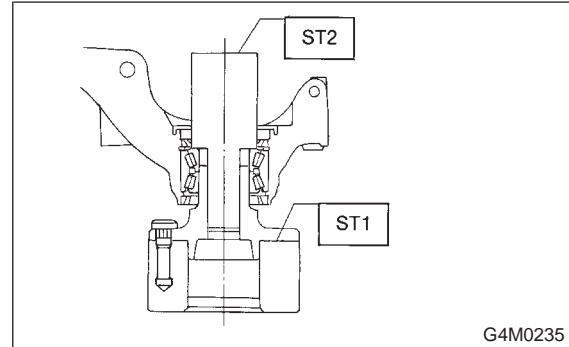

## E: INSTALLATION

1) Install transverse link ball joint to housing.

**Tightening torque:**

**49±10 N-m (5±1 kg-m, 36±7 ft-lb)**

2) While aligning alignment mark on camber adjusting bolt head, connect housing and strut.

**CAUTION:**

**Use a new self-locking nut.**

**Tightening torque:**

**152<sup>+44</sup>/<sub>-20</sub> N-m (15.5<sup>+4.5</sup>/<sub>-2.0</sub> kg-m, 112<sup>+33</sup>/<sub>-14</sub> ft-lb)**

3) Install ABS sensor on housing.

**Tightening torque:**

**32±10 N-m (3.3±1.0 kg-m, 24±7 ft-lb)**

4) Install ABS sensor harness on housing.

5) Install disc rotor on hub.

6) Install disc brake caliper on housing.

**Tightening torque:**

**78±10 N-m (8±1 kg-m, 58±7 ft-lb)**

7) Install front drive shaft. <Ref. to 4-2 [W3E1].>

8) Connect stabilizer link.

## 2. Rear Axle

9) Install tie-rod end ball joint on housing knuckle arm.

**Tightening torque:**

**$27.0 \pm 2.5 \text{ N}\cdot\text{m}$  ( $2.75 \pm 0.25 \text{ kg}\cdot\text{m}$ ,  $19.9 \pm 1.8 \text{ ft}\cdot\text{lb}$ )**

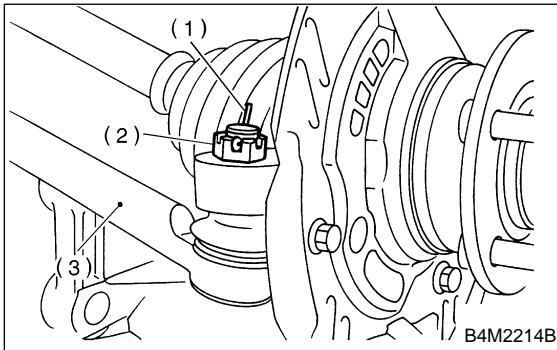

- (1) Cotter pin
- (2) Castle nut
- (3) Tie-rod

10) While depressing brake pedal, tighten axle nut and lock it securely.

**CAUTION:**

- Use a new axle nut.
- Always tighten axle nut before installing wheel on vehicle. If wheel is installed and comes in contact with ground when axle nut is loose, wheel bearings may be damaged.
- Be sure to tighten axle nut to specified torque. Do not overtighten it as this may damage wheel bearing.

**Tightening torque:**

**$186 \pm 20 \text{ N}\cdot\text{m}$  ( $19 \pm 2 \text{ kg}\cdot\text{m}$ ,  $137 \pm 14 \text{ ft}\cdot\text{lb}$ )**

11) After tightening axle nut, lock it securely.

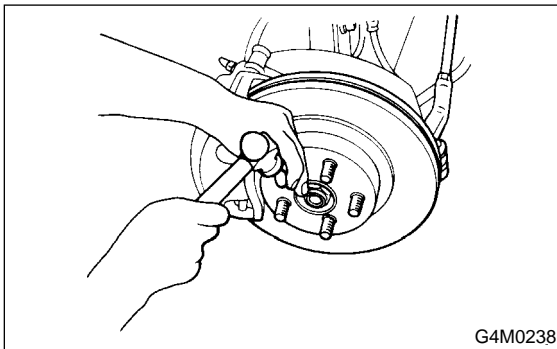

12) Install wheel and tighten wheel nuts to specified torque.

**Tightening torque:**

**$88 \pm 10 \text{ N}\cdot\text{m}$  ( $9 \pm 1 \text{ kg}\cdot\text{m}$ ,  $65 \pm 7 \text{ ft}\cdot\text{lb}$ )**

**2. Rear Axle****A: REMOVAL****1. DISC BRAKE**

- 1) Disconnect ground cable from battery.
- 2) Jack-up vehicle, and remove rear wheel cap and wheels.

**CAUTION:**

**Be sure to loosen and retighten axle nut after removing wheel from vehicle. Failure to follow this rule may damage wheel bearings.**

- 3) Unlock axle nut.
- 4) Remove axle nut using a socket wrench.
- 5) Return parking brake lever and loosen adjusting nut.

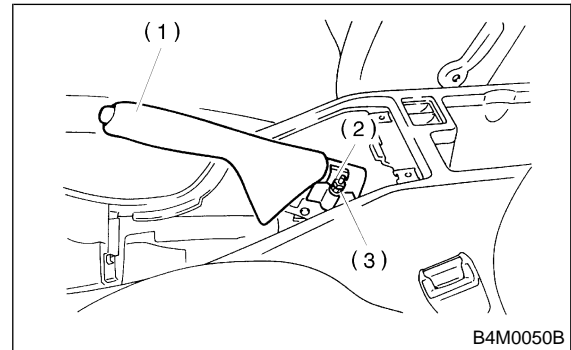

- (1) Parking brake lever
- (2) Lock nut
- (3) Adjusting nut

6) Remove disc brake caliper from back plate, and suspend it from strut using a piece of wire.

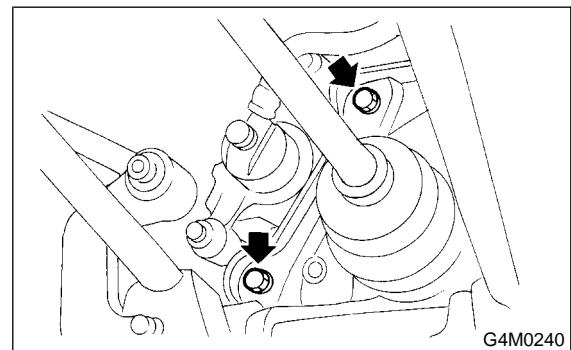

7) Remove disc rotor from hub.

**NOTE:**

If disc rotor seizes up within hub, drive it out by installing an 8-mm bolt into bolt hole in disc rotor.

## 2. Rear Axle

9) Install tie-rod end ball joint on housing knuckle arm.

**Tightening torque:**

**$27.0 \pm 2.5 \text{ N}\cdot\text{m}$  ( $2.75 \pm 0.25 \text{ kg}\cdot\text{m}$ ,  $19.9 \pm 1.8 \text{ ft}\cdot\text{lb}$ )**

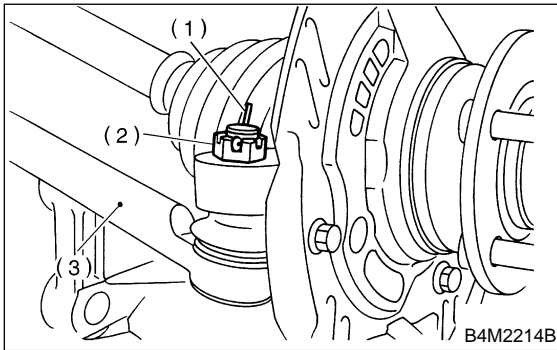

- (1) Cotter pin
- (2) Castle nut
- (3) Tie-rod

10) While depressing brake pedal, tighten axle nut and lock it securely.

**CAUTION:**

- Use a new axle nut.
- Always tighten axle nut before installing wheel on vehicle. If wheel is installed and comes in contact with ground when axle nut is loose, wheel bearings may be damaged.
- Be sure to tighten axle nut to specified torque. Do not overtighten it as this may damage wheel bearing.

**Tightening torque:**

**$186 \pm 20 \text{ N}\cdot\text{m}$  ( $19 \pm 2 \text{ kg}\cdot\text{m}$ ,  $137 \pm 14 \text{ ft}\cdot\text{lb}$ )**

11) After tightening axle nut, lock it securely.

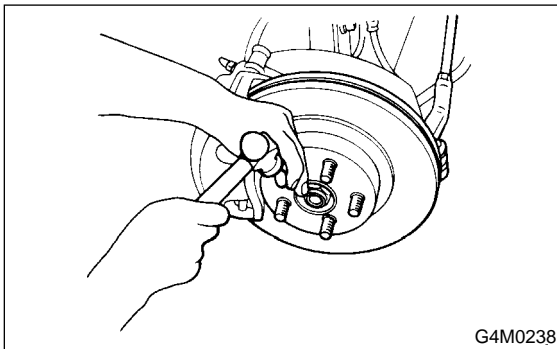

12) Install wheel and tighten wheel nuts to specified torque.

**Tightening torque:**

**$88 \pm 10 \text{ N}\cdot\text{m}$  ( $9 \pm 1 \text{ kg}\cdot\text{m}$ ,  $65 \pm 7 \text{ ft}\cdot\text{lb}$ )**

**2. Rear Axle****A: REMOVAL****1. DISC BRAKE**

- 1) Disconnect ground cable from battery.
- 2) Jack-up vehicle, and remove rear wheel cap and wheels.

**CAUTION:**

**Be sure to loosen and retighten axle nut after removing wheel from vehicle. Failure to follow this rule may damage wheel bearings.**

- 3) Unlock axle nut.
- 4) Remove axle nut using a socket wrench.
- 5) Return parking brake lever and loosen adjusting nut.

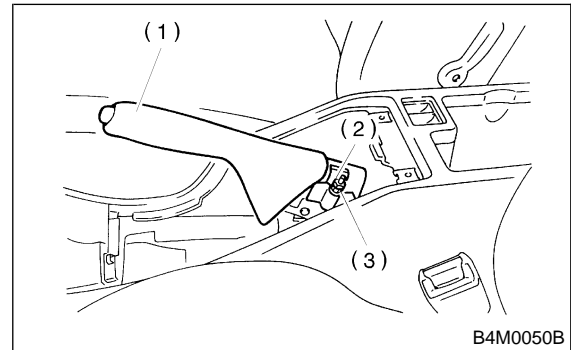

- (1) Parking brake lever
- (2) Lock nut
- (3) Adjusting nut

6) Remove disc brake caliper from back plate, and suspend it from strut using a piece of wire.

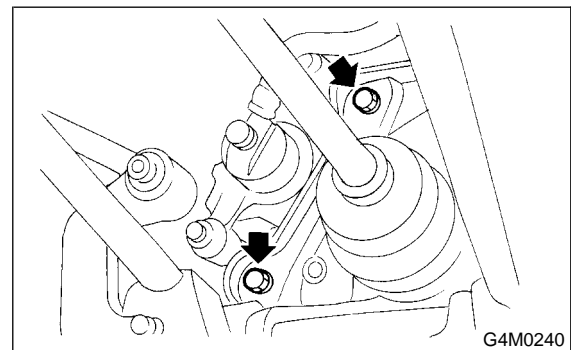

7) Remove disc rotor from hub.

**NOTE:**

If disc rotor seizes up within hub, drive it out by installing an 8-mm bolt into bolt hole in disc rotor.



8) Disconnect parking brake cable end.

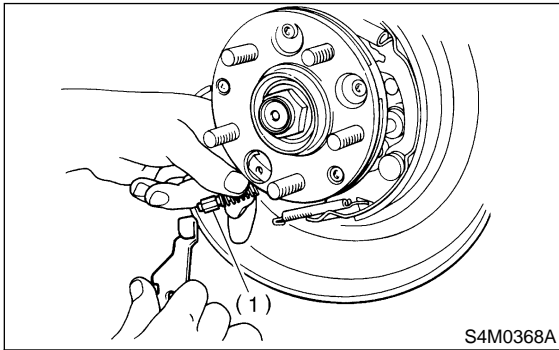

(1) Cable end

9) Disconnect rear stabilizer from rear lateral link.  
 10) Remove bolts which secure trailing link assembly to rear housing.

**CAUTION:**

Discard old self-locking nut. Replace with a new one.

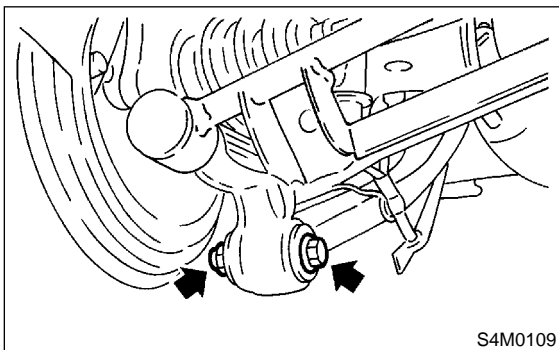

11) Remove bolts which secure lateral link assembly to rear housing.

**CAUTION:**

Discard old self-locking nut. Replace with a new one.

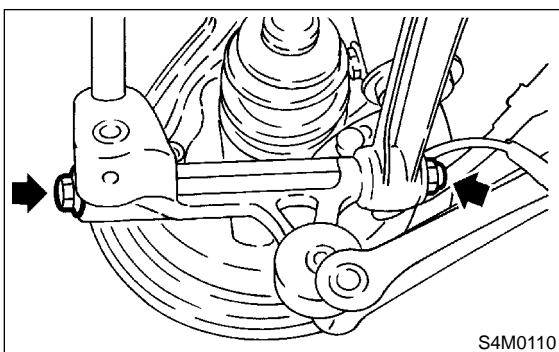

12) Disengage BJ from housing splines, and remove rear drive shaft assembly. If it is hard to remove, use STs.

ST1 926470000 AXLE SHAFT PULLER

ST2 927140000 PLATE

**CAUTION:**

- Be careful not to damage oil seal lip when removing rear drive shaft.
- When rear drive shaft is to be replaced, also replace inner oil seal with a new one.

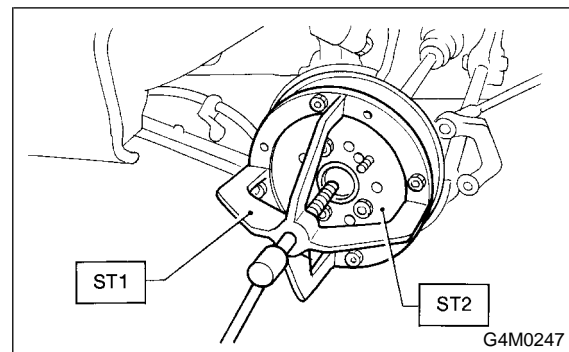

13) Remove rear ABS sensor from back plate.

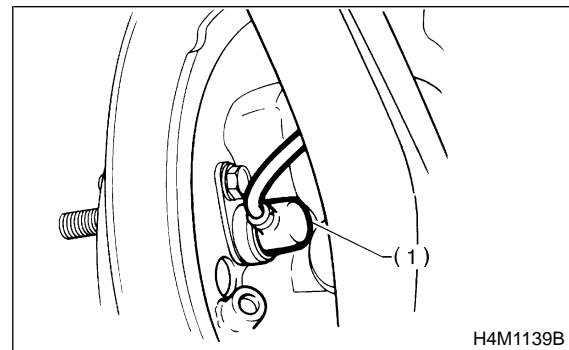

(1) ABS sensor

14) Remove bolts which secure rear housing to strut, and separate the two.

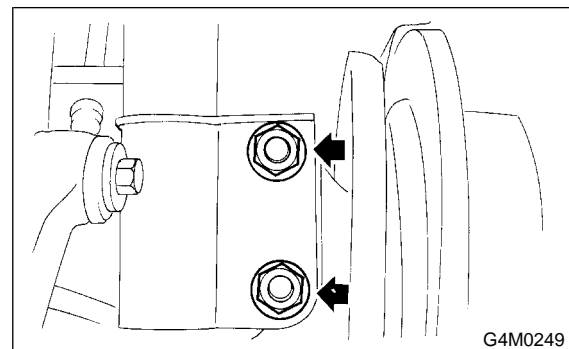

2. Rear Axle

2. DRUM BRAKE

- 1) Disconnect ground cable from battery.
- 2) Jack-up vehicle, and remove rear wheel cap and wheels.

**CAUTION:**

Be sure to loosen and retighten axle nut after removing wheel from vehicle. Failure to follow this rule may damage wheel bearings.

- 3) Unlock axle nut.
- 4) Remove axle nut using a socket wrench.
- 5) Return parking brake lever and loosen adjusting nut.

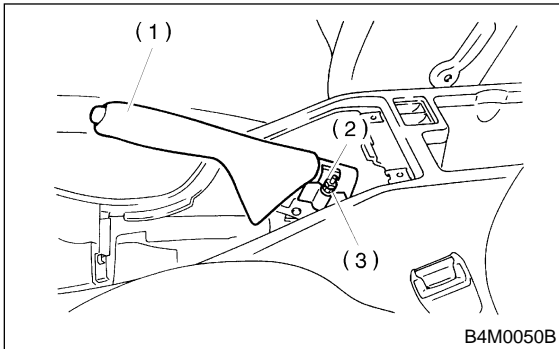

- (1) Parking brake lever
- (2) Lock nut
- (3) Adjusting nut

- 6) Remove brake drum from hub.
- 7) If it is difficult to remove brake drum, remove adjusting hole cover from back plate, and then turn adjusting screw using a slot-type screwdriver until brake shoe separates from the drum.

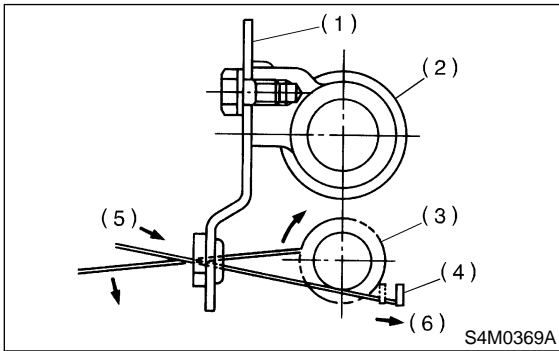

- (1) Back plate
- (2) Wheel cylinder
- (3) Adjuster ASSY pawls
- (4) Adjusting lever
- (5) Tightening direction
- (6) Push

**NOTE:**

If brake drum is difficult to remove, drive it out by installing an 8-mm bolt into bolt hole in brake drum.

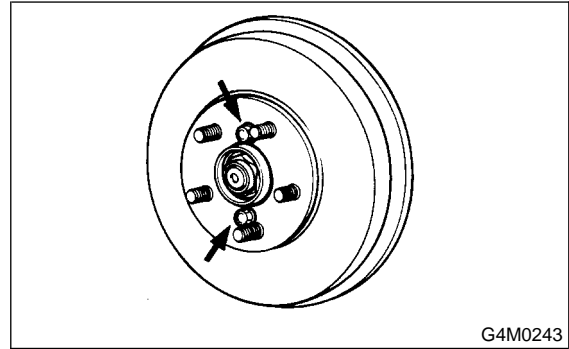

- 8) Using a flare-nut wrench, disconnect brake pipe from wheel cylinder.

**CAUTION:**

Cover open end of wheel cylinder to prevent entry of foreign particles.

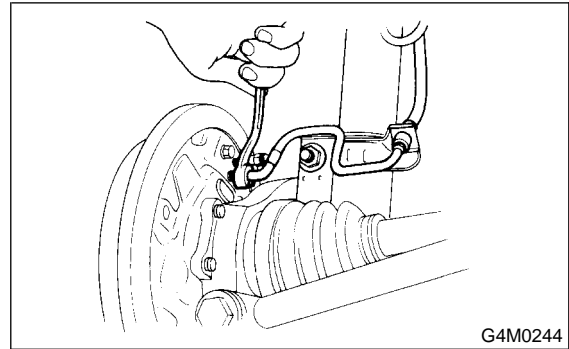

- 9) Disconnect parking brake cable end.

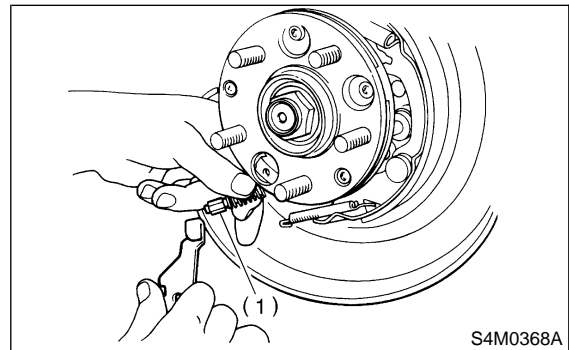

- (1) Cable end

- 10) Disconnect rear stabilizer from rear lateral link.

11) Remove bolts which secure trailing link assembly to rear housing.

**CAUTION:**

Discard old self-locking nut. Replace with a new one.

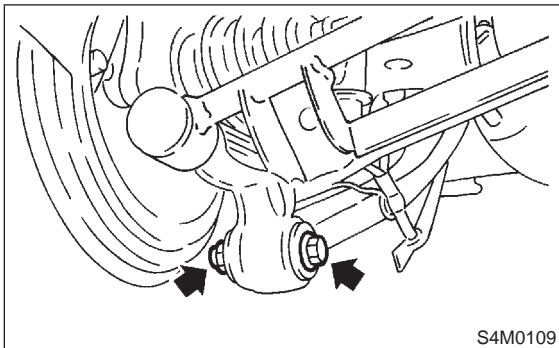

12) Remove bolts which secure lateral link assembly to rear housing.

**CAUTION:**

Discard old self-locking nut. Replace with a new one.

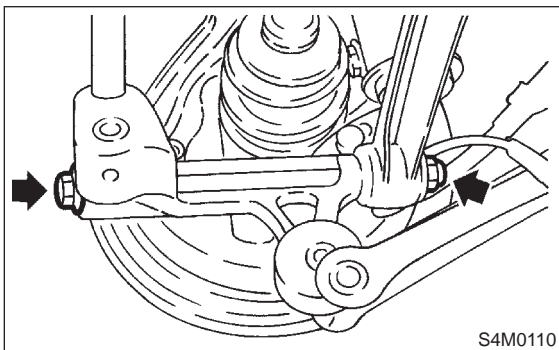

13) Disengage BJ from housing splines, and remove rear drive shaft assembly. If it is hard to remove, use STs.

ST1 926470000 AXLE SHAFT PULLER

ST2 927140000 PLATE

**CAUTION:**

- Be careful not to damage oil seal lip when removing rear drive shaft.
- When rear drive shaft is to be replaced, also replace inner oil seal with a new one.

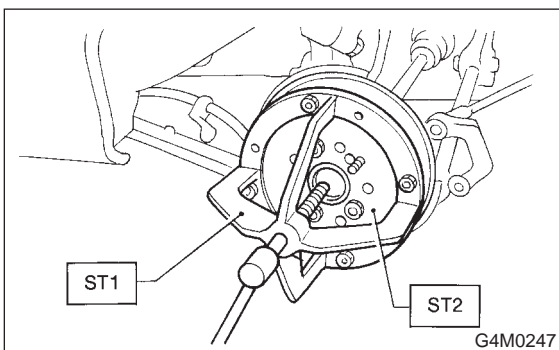

14) Remove rear ABS sensor from back plate.

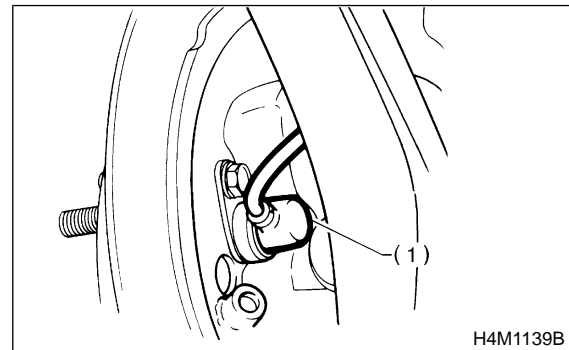

(1) ABS sensor

15) Remove bolts which secure rear housing to strut, and separate the two.

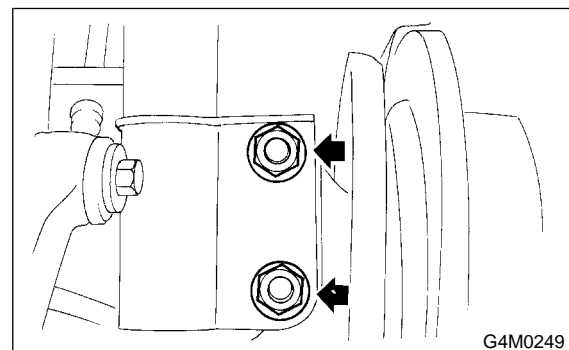

## B: DISASSEMBLY

1) Using ST1 and ST2, remove hub from rear housing.

ST1 927080000 HUB STAND

ST2 927420000 HUB REMOVER

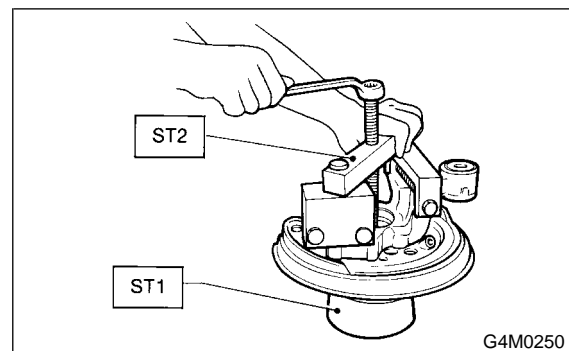

2) Remove back plate from rear housing.

3) Using a standard screwdriver, remove outer and inner oil seals.

**CAUTION:**

Use new oil seals.

4) Using flat bladed screwdriver, remove snap ring.

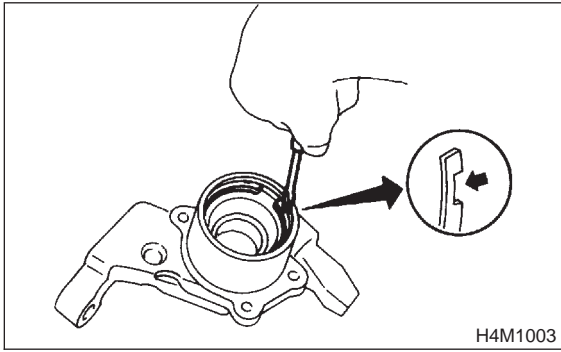

5) Using ST1 and ST2, remove bearing by pressing inner race.

- ST1 927430000 HOUSING STAND
- ST2 927440000 BEARING REMOVER

**CAUTION:**

- Do not remove bearing unless damaged.
- Do not re-use bearing after removal.

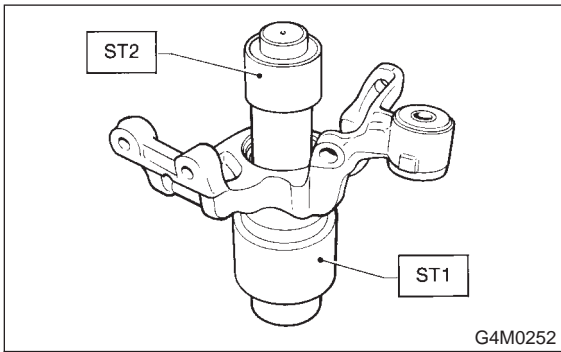

6) Remove tone wheel bolts and remove tone wheel from hub.

7) Using ST, press hub bolts out.

**CAUTION:**

Be careful not to hammer hub bolts. This may deform hub.

- ST 927080000 HUB STAND

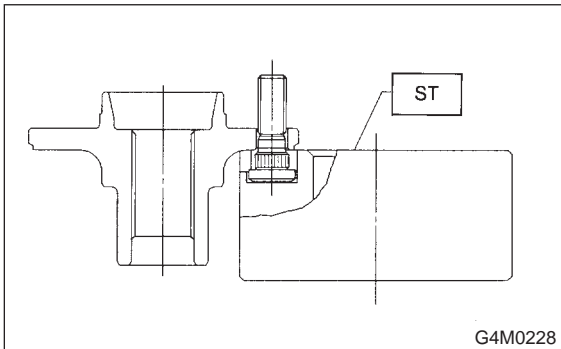

**C: INSPECTION**

Check the removed parts for wear and damage. If defective, replace with new ones.

**CAUTION:**

- If a bearing is faulty, replace it as a bearing set.
- Be sure to replace oil seal at every overhaul.

**D: ASSEMBLY**

1) Using ST, press new hub bolt into place.

**CAUTION:**

- Ensure hub bolt closely contacts hub.
- Use a 12 mm (0.47 in) hole in the ST to prevent hub bolt from tilting during installation.

- ST 927080000 HUB STAND

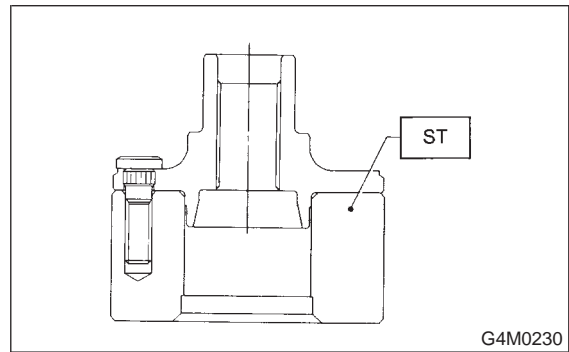

2) Remove foreign particles (dust, rust, etc.) from mating surfaces of hub and tone wheel, and install tone wheel to hub.

**CAUTION:**

- Ensure tone wheel closely contacts hub.
- Be careful not to damage tone wheel teeth.

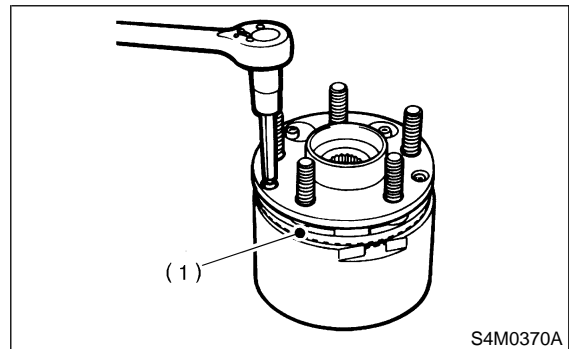

(1) Tone wheel

3) Clean housing interior completely. Using ST1 and ST2, press bearing into housing.

ST1 927430000 HOUSING STAND  
ST2 927440000 BEARING REMOVER

**CAUTION:**

- Always press outer race when installing bearing.
- Be careful not to remove plastic lock from inner race when installing bearing.
- Charge bearing with new grease when outer race is not removed.

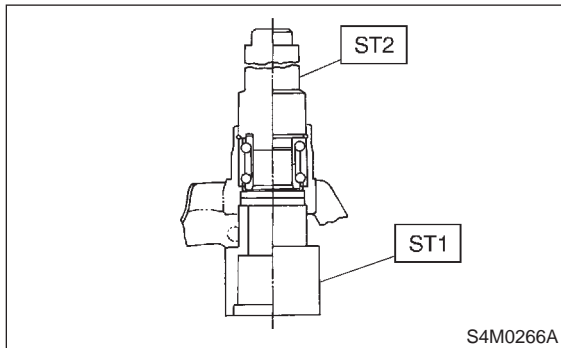

4) Install snap ring.

**CAUTION:**

Ensure snap ring fits in groove properly.

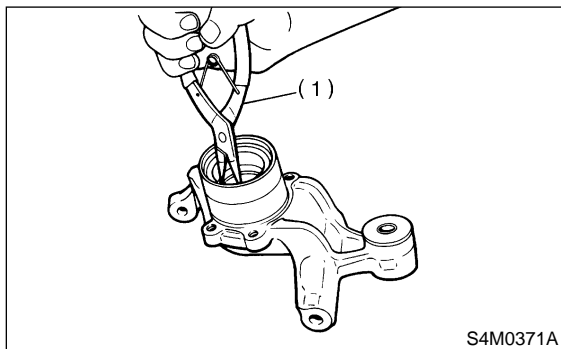

(1) Plier

5) Using ST1 and ST2, press outer oil seal until it comes in contact with snap ring.

ST1 927430000 HOUSING STAND  
ST2 927460000 OIL SEAL INSTALLER

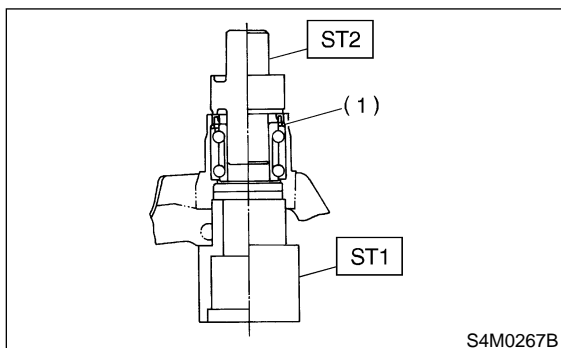

(1) Snap ring

6) Invert both ST1 and housing.

7) Using ST2, press inner oil seal into housing until it touches bottom.

ST1 927430000 HOUSING STAND  
ST2 927460000 OIL SEAL INSTALLER

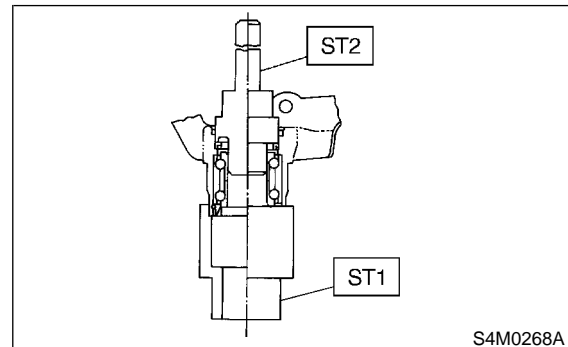

8) Using ST1 and ST2, press sub seal into place.

ST1 927430000 HOUSING STAND  
ST2 927460000 OIL SEAL INSTALLER

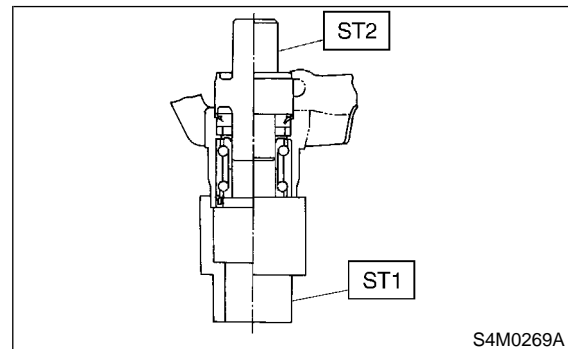

9) Apply sufficient grease to oil seal lip.

**Specified grease:**  
**SHELL 6459N**

**CAUTION:**

- If specified grease is not available, remove bearing grease and apply Auto Rex A instead.
- Do not mix different types of grease.

10) Install back plate to rear housing.

**Tightening torque:**

$52^{+10}/_{-6}$  N·m ( $5.3^{+1.0}/_{-0.6}$  kg·m,  $38.3^{+7.2}/_{-4.3}$  ft·lb)

2. Rear Axle

11) Using ST1 and ST2, press bearing into hub.

ST1 927080000 HUB STAND

ST2 927450000 HUB INSTALLER

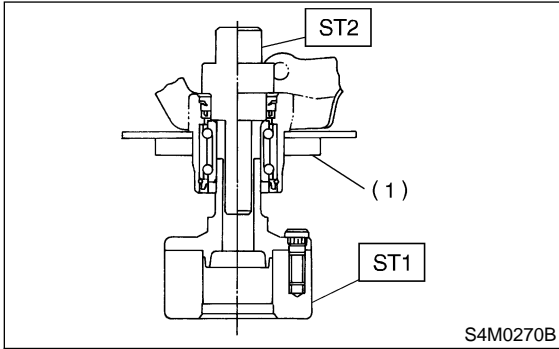

(1) Back plate

**E: INSTALLATION**

**1. DISC BRAKE**

1) Connect rear housing assembly and strut assembly.

**CAUTION:**

Use a new self-locking nut.

**Tightening torque:**

$196^{+39}/_{-10}$  N·m ( $20^{+4}/_{-1}$  kg-m,  $145^{+29}/_{-7}$  ft-lb)

2) Fit BJ (bell joint) to rear housing splines.

**CAUTION:**

Be careful not to damage inner oil seal lip.

3) Connect rear housing assembly to lateral link assembly.

**CAUTION:**

Use a new self-locking nut.

**Tightening torque:**

$137\pm 20$  N·m ( $14\pm 2$  kg-m,  $101\pm 14$  ft-lb)

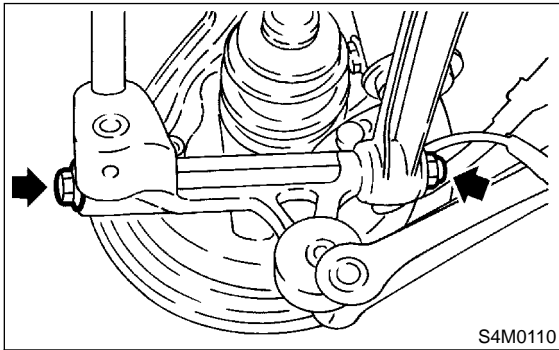

4) Connect rear housing assembly to trailing link assembly.

**CAUTION:**

Use a new self-locking nut.

**Tightening torque:**

$113\pm 15$  N·m ( $11.5\pm 1.5$  kg-m,  $83\pm 11$  ft-lb)

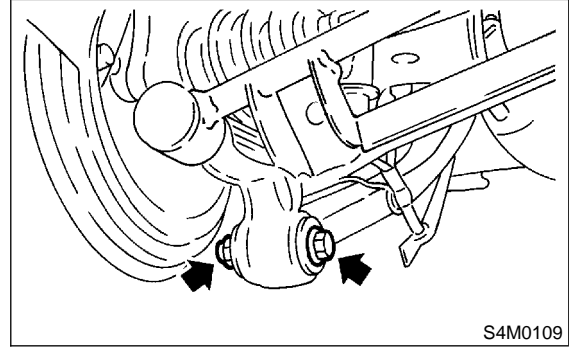

5) Connect rear stabilizer to rear lateral link.

**CAUTION:**

Use a new self-locking nut.

**Tightening torque:**

$44\pm 6$  N·m ( $4.5\pm 0.6$  kg-m,  $32.5\pm 4.3$  ft-lb)

6) Connect parking brake cable to parking brake.

7) Install disc rotor on rear housing assembly.

8) Install disc brake caliper on back plate.

**Tightening torque:**

$52^{+10}/_{-6}$  N·m ( $5.3^{+1.0}/_{-0.6}$  kg-m,  $38.3^{+7.2}/_{-4.3}$  ft-lb)

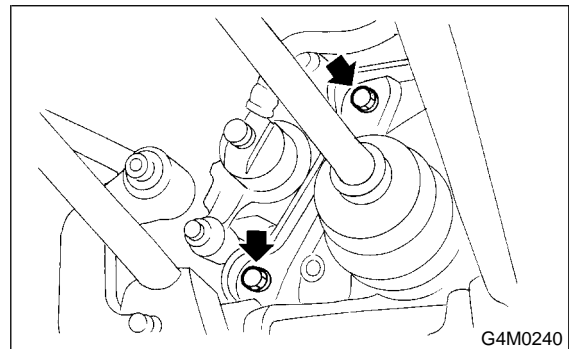

9) Install rear ABS sensor to back plate.

**Tightening torque:**

**$32 \pm 10 \text{ N}\cdot\text{m}$  ( $3.3 \pm 1.0 \text{ kg}\cdot\text{m}$ ,  $24 \pm 7 \text{ ft}\cdot\text{lb}$ )**

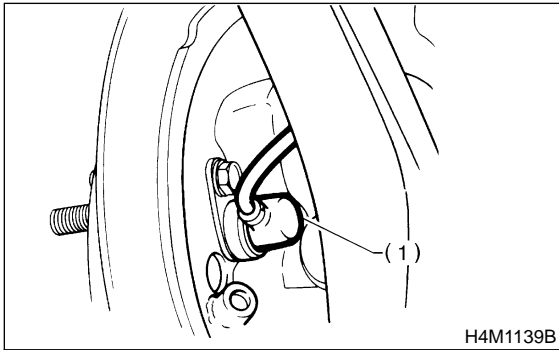

(1) ABS sensor

10) Bleed air from brake system. <Ref. to 4-4 [W10B0].>

11) Adjust parking brake lever stroke by turning adjuster.

12) Move brake lever back to apply brakes. While depressing brake pedal, tighten axle nut using a socket wrench. Lock axle nut after tightening.

**Tightening torque:**

**$186 \pm 20 \text{ N}\cdot\text{m}$  ( $19 \pm 2 \text{ kg}\cdot\text{m}$ ,  $137 \pm 14 \text{ ft}\cdot\text{lb}$ )**

**CAUTION:**

- Use a new axle nut.
- Always tighten axle nut before installing wheel on vehicle. If wheel is installed and comes in contact with ground when axle nut is loose, wheel bearings may be damaged.
- Be sure to tighten axle nut to specified torque. Do not overtighten it as this may damage wheel bearing.

13) Install wheel and tighten wheel nuts to specified torque.

**Tightening torque:**

**$88 \pm 10 \text{ N}\cdot\text{m}$  ( $9 \pm 1 \text{ kg}\cdot\text{m}$ ,  $65 \pm 7 \text{ ft}\cdot\text{lb}$ )**

**2. DRUM BRAKE**

1) Connect rear housing assembly and strut assembly.

**CAUTION:**

**Use a new self-locking nut.**

**Tightening torque:**

**$196^{+39}_{-10} \text{ N}\cdot\text{m}$  ( $20^{+4}_{-1} \text{ kg}\cdot\text{m}$ ,  $145^{+29}_{-7} \text{ ft}\cdot\text{lb}$ )**

2) Fit BJ (bell joint) to rear housing splines.

**CAUTION:**

**Be careful not to damage inner oil seal lip.**

3) Connect rear housing assembly to lateral link assembly.

**CAUTION:**

**Use a new self-locking nut.**

**Tightening torque:**

**$137 \pm 20 \text{ N}\cdot\text{m}$  ( $14 \pm 2 \text{ kg}\cdot\text{m}$ ,  $101 \pm 14 \text{ ft}\cdot\text{lb}$ )**

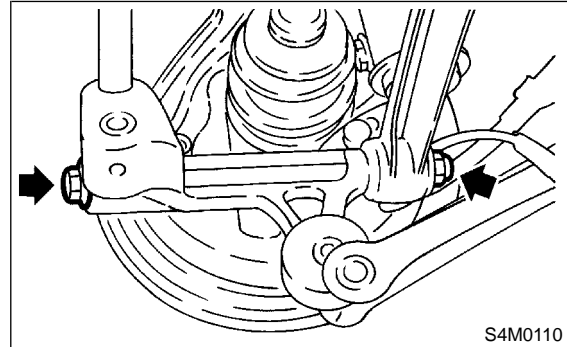

S4M0110

4) Connect rear housing assembly to trailing link assembly.

**CAUTION:**

**Use a new self-locking nut.**

**Tightening torque:**

**$113 \pm 15 \text{ N}\cdot\text{m}$  ( $11.5 \pm 1.5 \text{ kg}\cdot\text{m}$ ,  $83 \pm 11 \text{ ft}\cdot\text{lb}$ )**

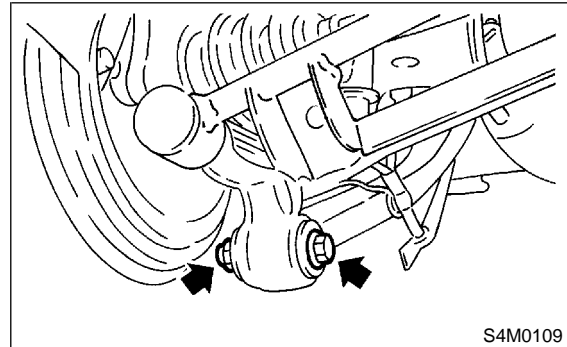

S4M0109

5) Connect rear stabilizer to rear lateral link.

**CAUTION:**

**Use a new self-locking nut.**

**Tightening torque:**

**$44 \pm 6 \text{ N}\cdot\text{m}$  ( $4.5 \pm 0.6 \text{ kg}\cdot\text{m}$ ,  $32.5 \pm 4.3 \text{ ft}\cdot\text{lb}$ )**

6) Connect parking brake cable to parking brake.

7) Clean brake pipe connection. Using a flare-nut wrench, connect brake pipe to wheel cylinder.

## 3. Front and Rear Drive Shafts

8) Connect rear ABS sensor to back plate.

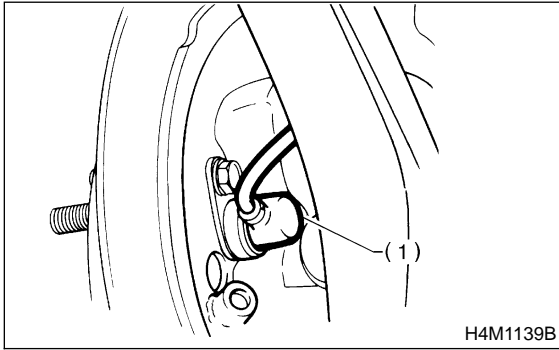

(1) ABS sensor

- 9) Connect parking brake cable to lever.  
 10) Install brake drum on rear housing assembly.  
 11) Bleed air from brake system. <Ref. to 4-4 [W10B0].>  
 12) Adjust parking brake lever stroke by turning adjuster.  
 13) Move brake lever back to apply brakes. While depressing brake pedal, tighten axle nut using a socket wrench. Lock axle nut after tightening.

**Tightening torque:**

**186±20 N·m (19±2 kg·m, 137±14 ft·lb)**

**CAUTION:**

- Use a new axle nut.
- Always tighten axle nut before installing wheel on vehicle. If wheel is installed and comes in contact with ground when axle nut is loose, wheel bearings may be damaged.
- Be sure to tighten axle nut to specified torque. Do not overtighten it as this may damage wheel bearing.

14) Install wheel and tighten wheel nuts to specified torque.

**Tightening torque:**

**88±10 N·m (9±1 kg·m, 65±7 ft·lb)**

### 3. Front and Rear Drive Shafts

#### A: REMOVAL

##### 1. FRONT DRIVE SHAFT

- 1) Disconnect ground cable from battery.
- 2) Jack-up vehicle, support it with safety stands (rigid racks), and remove front wheel cap and wheels.
- 3) Unlock axle nut.
- 4) While depressing brake pedal, remove axle nut using a socket wrench.

**CAUTION:**

**Be sure to loosen and retighten axle nut after removing wheel from vehicle. Failure to follow this rule may damage wheel bearings.**

- 5) Disconnect stabilizer link from transverse link.
- 6) Disconnect transverse link from housing.
- 7) Remove spring pin which secures transmission spindle to SFJ.

**CAUTION:**

**Use a new spring pin.**

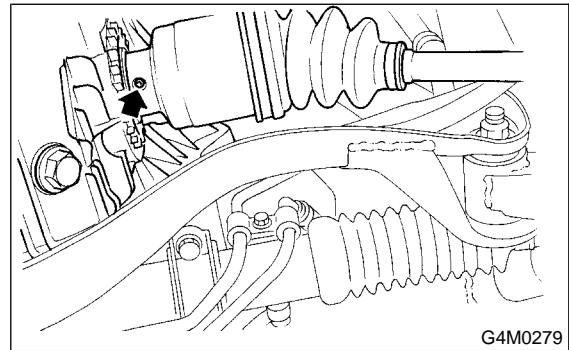

8) Remove front drive shaft assembly. If it is hard to remove, use ST1 and ST2.

ST1 926470000 AXLE SHAFT PULLER  
 ST2 927140000 PLATE

**CAUTION:**

- Be careful not to damage oil seal lip when removing front drive shaft.
- When front drive shaft is to be replaced, also replace inner oil seal.

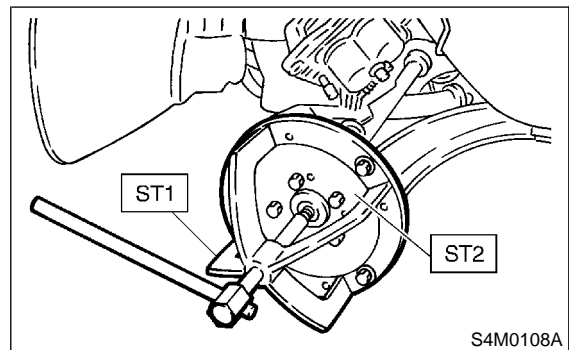



## 3. Front and Rear Drive Shafts

8) Connect rear ABS sensor to back plate.

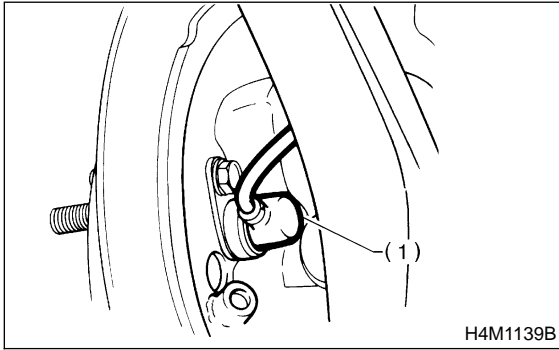

(1) ABS sensor

- 9) Connect parking brake cable to lever.  
 10) Install brake drum on rear housing assembly.  
 11) Bleed air from brake system. <Ref. to 4-4 [W10B0].>  
 12) Adjust parking brake lever stroke by turning adjuster.  
 13) Move brake lever back to apply brakes. While depressing brake pedal, tighten axle nut using a socket wrench. Lock axle nut after tightening.

**Tightening torque:**

**186±20 N·m (19±2 kg·m, 137±14 ft·lb)**

**CAUTION:**

- Use a new axle nut.
- Always tighten axle nut before installing wheel on vehicle. If wheel is installed and comes in contact with ground when axle nut is loose, wheel bearings may be damaged.
- Be sure to tighten axle nut to specified torque. Do not overtighten it as this may damage wheel bearing.

14) Install wheel and tighten wheel nuts to specified torque.

**Tightening torque:**

**88±10 N·m (9±1 kg·m, 65±7 ft·lb)**

## 3. Front and Rear Drive Shafts

### A: REMOVAL

#### 1. FRONT DRIVE SHAFT

- 1) Disconnect ground cable from battery.
- 2) Jack-up vehicle, support it with safety stands (rigid racks), and remove front wheel cap and wheels.
- 3) Unlock axle nut.
- 4) While depressing brake pedal, remove axle nut using a socket wrench.

**CAUTION:**

**Be sure to loosen and retighten axle nut after removing wheel from vehicle. Failure to follow this rule may damage wheel bearings.**

- 5) Disconnect stabilizer link from transverse link.
- 6) Disconnect transverse link from housing.
- 7) Remove spring pin which secures transmission spindle to SFJ.

**CAUTION:**

**Use a new spring pin.**

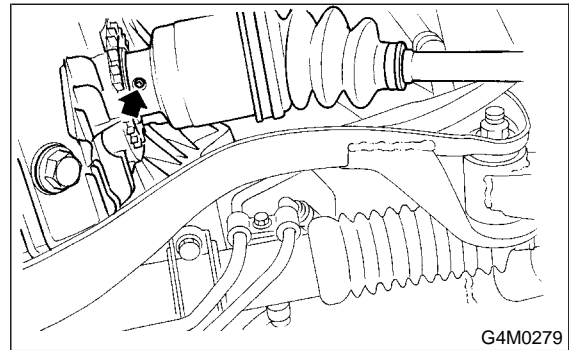

G4M0279

8) Remove front drive shaft assembly. If it is hard to remove, use ST1 and ST2.

ST1 926470000 AXLE SHAFT PULLER

ST2 927140000 PLATE

**CAUTION:**

- Be careful not to damage oil seal lip when removing front drive shaft.
- When front drive shaft is to be replaced, also replace inner oil seal.

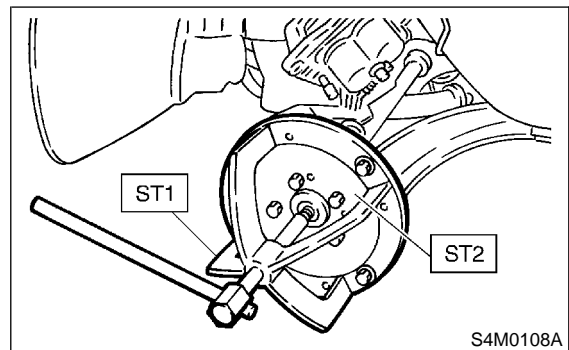

S4M0108A

**2. REAR DRIVE SHAFT**

- 1) Disconnect ground cable from battery.
- 2) Lift-up vehicle, and remove rear wheel cap and wheels.

**CAUTION:**

**Be sure to loosen and retighten axle nut after removing wheel from vehicle. Failure to follow this rule may damage wheel bearings.**

- 3) Unlock axle nut.
- 4) Loosen axle nut using a socket wrench.

**CAUTION:**

**Do not remove axle nut.**

- 5) Remove ABS sensor clamps and parking brake cable bracket.
- 6) Remove bolts which secure lateral link assembly to rear housing.

**CAUTION:**

**Discard old self-locking nut. Replace with a new one.**

- 7) Remove bolts which secure trailing link assembly to rear housing.

**CAUTION:**

**Discard old self-locking nut. Replace with a new one.**

- 8) Remove DOJ from rear differential using ST.

**CAUTION:**

**Do not remove circlip attached to inside of differential.**

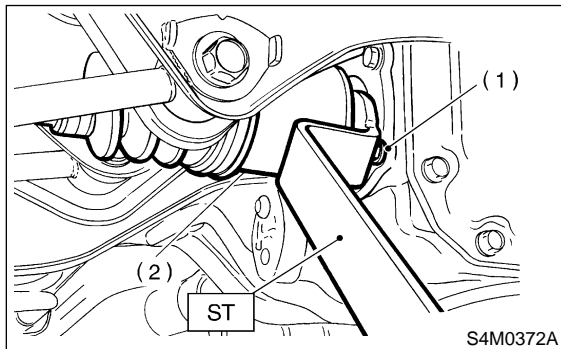

- (1) Bolt
- (2) DOJ

**CAUTION:**

**Be careful not to damage side bearing retainer. Always use bolt as shown in figure, as supporting point for ST during removal.**

ST 28099PA100 DRIVE SHAFT REMOVER

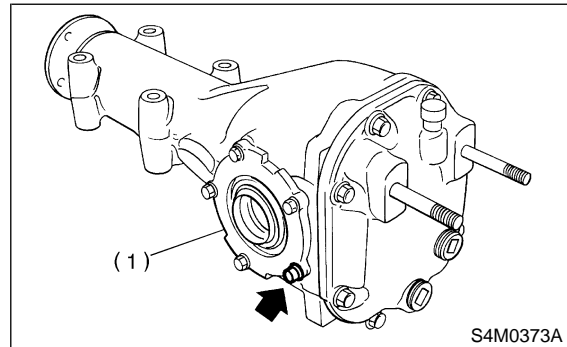

- (1) Side bearing retainer

- 9) Remove axle nut and drive shaft. If it is hard to remove, use ST1 and ST2.

ST1 926470000 AXLE SHAFT PULLER  
ST2 927140000 PLATE

**CAUTION:**

- Be careful not to damage oil seal lip when removing rear drive shaft.
- When rear drive shaft is to be replaced, also replace inner oil seal with a new one.

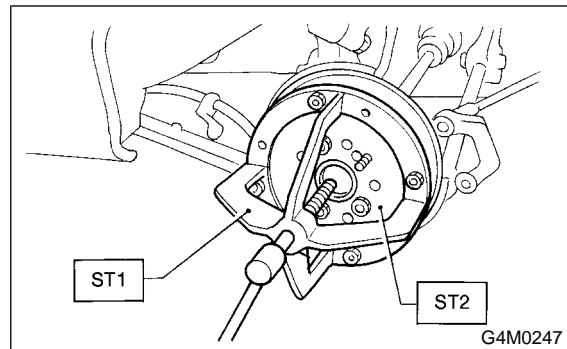

**B: DISASSEMBLY****1. FRONT DRIVE SHAFT**

- 1) Place alignment marks on shaft and outer race.

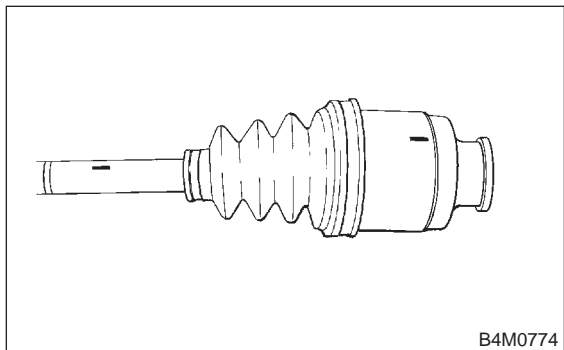

B4M0774

- 2) Remove SFJ boot band and boot.

**CAUTION:**

Be careful not to damage boot.

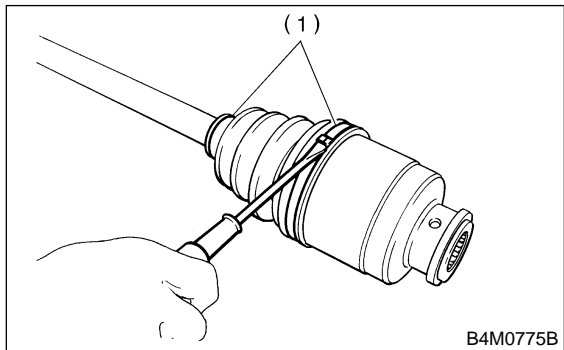

B4M0775B

(1) Boot band

- 3) Remove circlip from SFJ outer race using screwdriver.

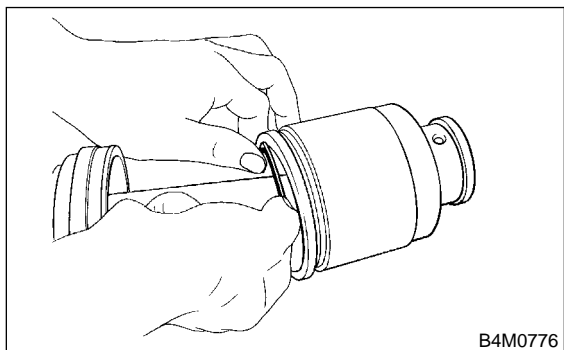

B4M0776

- 4) Remove SFJ outer race from shaft assembly.  
5) Wipe off grease.

**CAUTION:**

The grease is a special grease. Do not confuse with other greases.

- 6) Place alignment mark on free ring and trunnion.

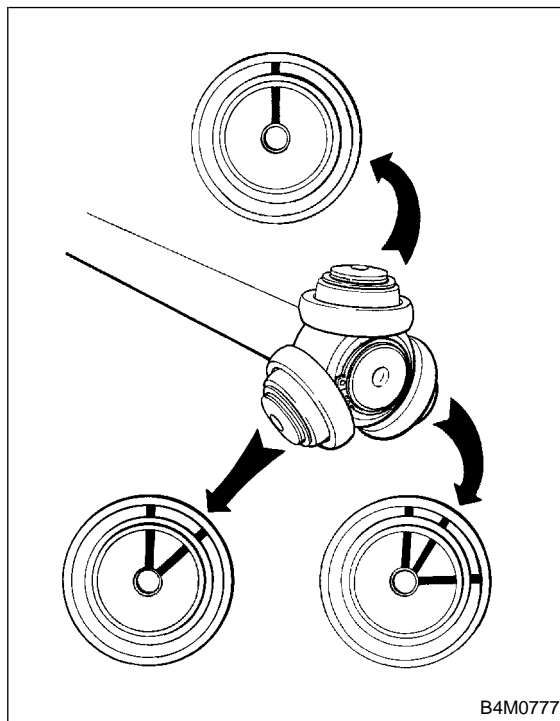

B4M0777

- 7) Remove free ring from trunnion.

**CAUTION:**

Be careful with the free ring position.

- 8) Place alignment mark on trunnion and shaft.

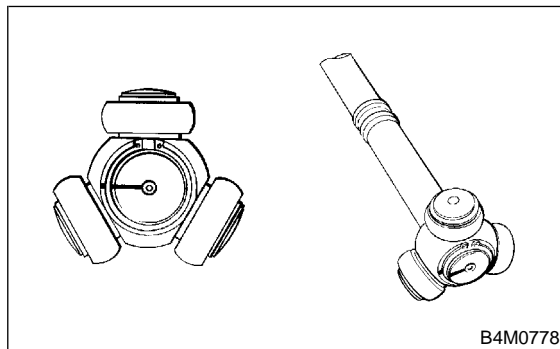

B4M0778

- 9) Remove snap ring and trunnion.

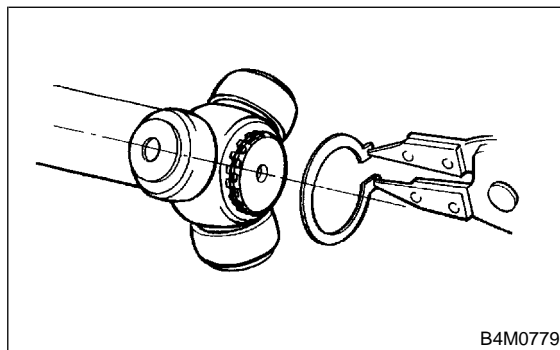

B4M0779

**CAUTION:**

Be sure to wrap shaft splines with vinyl tape to prevent boot from scratches.

- 10) Remove SFJ boot.
- 11) Place drive shaft in a vise between wooden blocks.

**CAUTION:**

**Do not place drive shaft directly in the vise; use wooden block.**

- 12) Raise boot band claws by means of screwdriver and hammer.

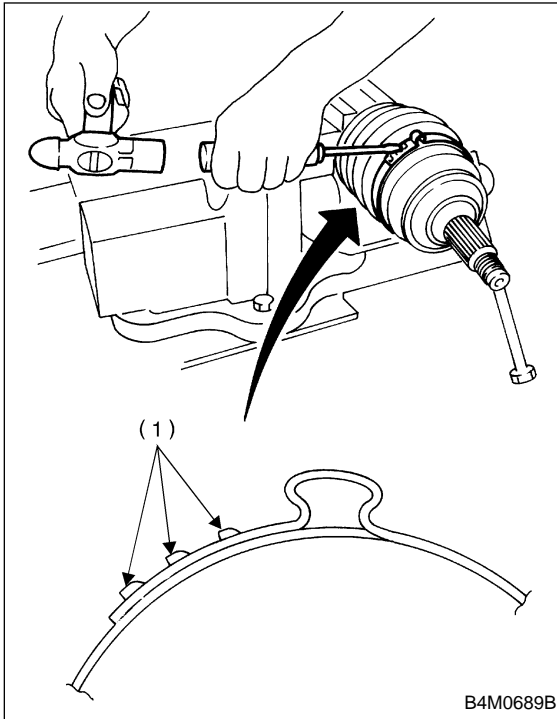

(1) Boot band claws

- 13) Cut and remove the boot.

**CAUTION:**

**The boot must be replaced with a new one whenever it is removed.**

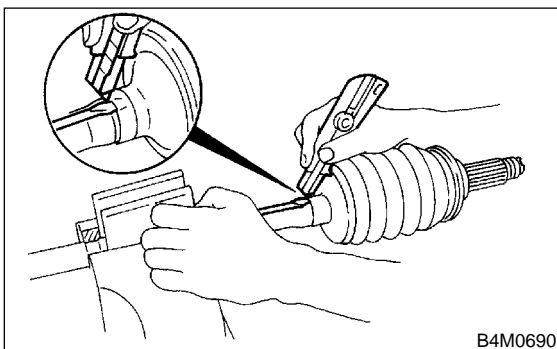

- 14) Thus, disassembly of axle is completed, but BJ cannot be disassembled.

## 2. REAR DRIVE SHAFT

- 1) Straighten bent claw of larger end of DOJ boot.

- 2) Loosen band by means of screwdriver or pliers with care of not damaging boot.

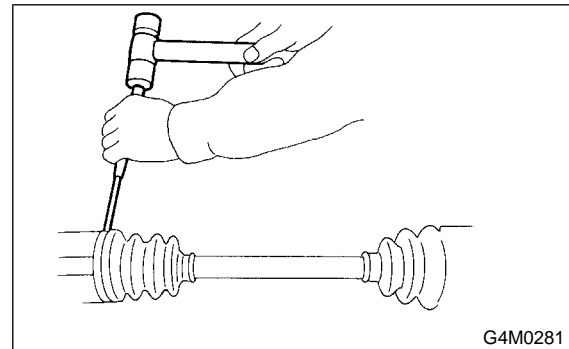

- 3) Remove boot band on the small end of DOJ boot in the same manner.
- 4) Remove the larger end of DOJ boot from DOJ outer race.
- 5) Pry and remove round circlip located at the neck of DOJ outer race with a screwdriver.

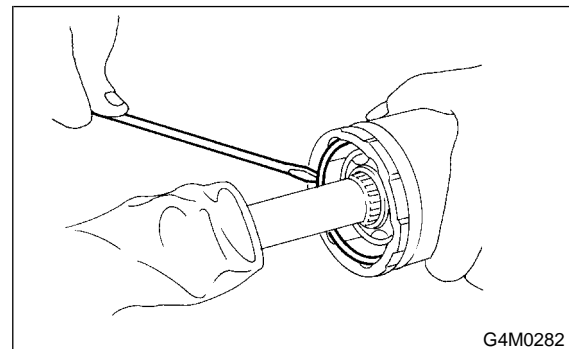

- 6) Take out DOJ outer race from shaft assembly.
- 7) Wipe off grease and take out balls.

**CAUTION:**

**The grease is a special grease (grease for constant velocity joint). Do not confuse with other greases.**

**NOTE:**

Disassemble exercising care not to lose balls (6 pcs).

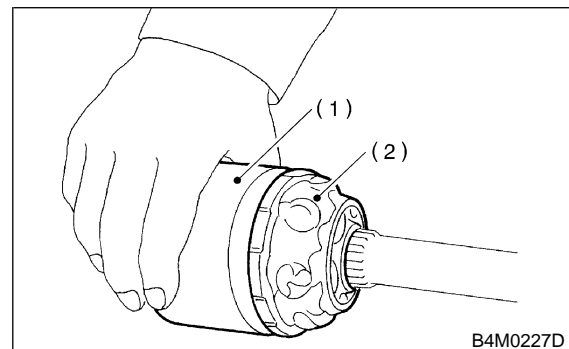

- (1) Outer race
- (2) Grease

## 3. Front and Rear Drive Shafts

- 8) To remove the cage from the inner race, turn the cage by a half pitch to the track groove of the inner race and shift the cage.
- 9) Remove snap ring, which fixes inner race to shaft, by using pliers.
- 10) Take out DOJ inner race.
- 11) Take off DOJ cage from shaft and remove DOJ boot.

**CAUTION:**

**Be sure to wrap shaft splines with vinyl tape to prevent boot from scratches.**

- 12) Remove BJ boot in the same procedure as DOJ boot.
- 13) Thus, disassembly of axle is completed, but BJ is unable to be disassembled.

**C: INSPECTION**

Check the removed parts for damage, wear, corrosion etc. If faulty, repair or replace.

- 1) DOJ (Double Offset Joint)  
Check seizure, corrosion, damage, wear and excessive play.
- 2) SFJ (Shudder-less Freering tripod Joint)  
Check seizure, corrosion, damage and excessive play.
- 3) Shaft  
Check excessive bending, twisting, damage and wear.
- 4) BJ (Bell Joint)  
Check seizure, corrosion, damage and excessive play.
- 5) Boot  
Check for wear, warping, breakage or scratches.
- 6) Grease  
Check for discoloration or fluidity.

**D: ASSEMBLY****1. FRONT DRIVE SHAFT****CAUTION:**

**Use specified grease.**

**BJ side:**

**NTG2218 (Part No. 28093AA000)**

**SFJ side:**

**SSG6003 (Part No. 28093TA000)**

- 1) Place BJ boot and small boot band on BJ side of shaft.

**CAUTION:**

**Be sure to wrap shaft splines with vinyl tape to prevent boot from scratches.**

- 2) Place drive shaft in a vise.

**CAUTION:**

**Do not place drive shaft directly in the vise; use wooden blocks.**

- 3) Apply a coat of specified grease [60 to 70 g (2.12 to 2.47 oz)] to BJ.
- 4) Apply an even coat of specified grease [20 to 30 g (0.71 to 1.06 oz)] to the entire inner surface of boot. Also apply grease to shaft.

**NOTE:**

The inside of the larger end of BJ boot and the boot groove shall be cleaned so as to be free from grease and other substances.

- 5) Install boot projecting portion to BJ groove.

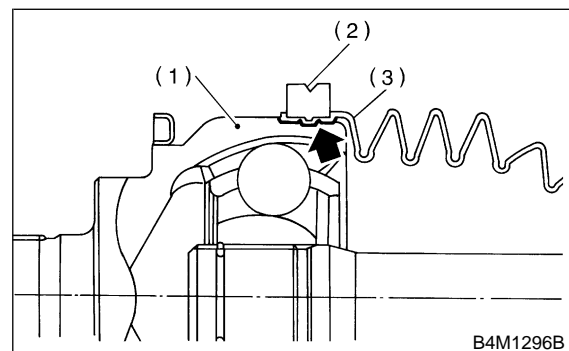

- (1) BJ
- (2) Large boot band
- (3) Boot

- 6) Set large boot band in place.

7) Install boot projecting portion to shaft groove.

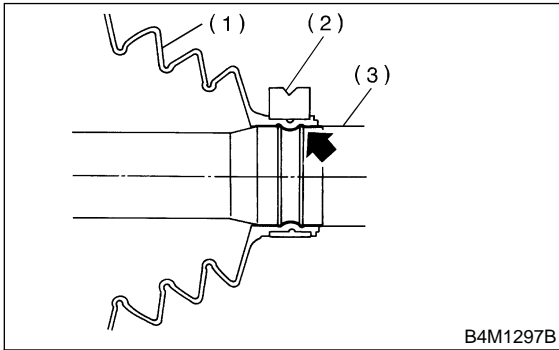

- (1) Boot
- (2) Small boot band
- (3) Shaft

8) Tighten boot bands using ST, torque wrench and socket flex handle.

ST 28099AC000 BOOT BAND PLIER

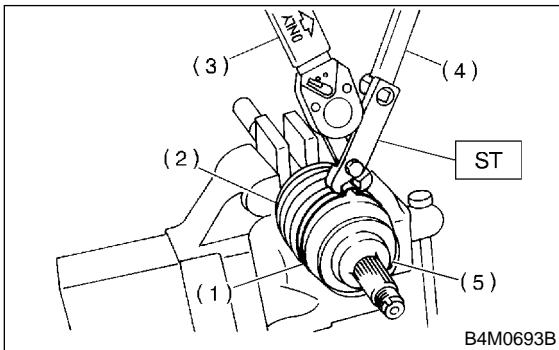

- (1) Large boot band
- (2) Boot
- (3) Torque wrench
- (4) Socket flex handle
- (5) BJ

**Tightening torque:**

**Large boot band**

**157 N-m (16.0 kg-m, 116 ft-lb) or more**

**Small boot band**

**133 N-m (13.6 kg-m, 98 ft-lb) or more**

9) Place SFJ boot at the center of shaft.  
10) Align alignment marks and install trunnion on shaft.

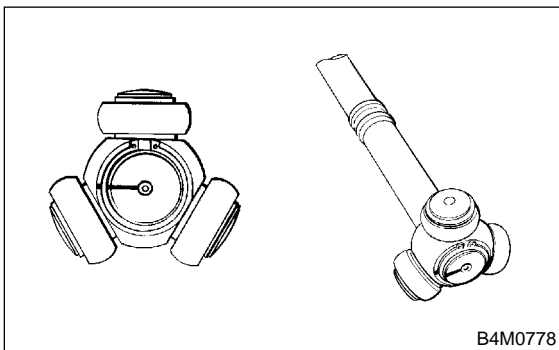

11) Install snap ring to shaft.

**CAUTION:**  
**Confirm that the snap ring is completely fitted in the shaft groove.**

12) Fill 100 to 110 g (3.53 to 3.88 oz) of specified grease into the interior of SFJ outer race.

13) Apply a coat of specified grease to free ring and trunnion.

14) Align alignment marks on free ring and trunnion and install free ring.

**CAUTION:**  
**Be careful with the free ring position.**

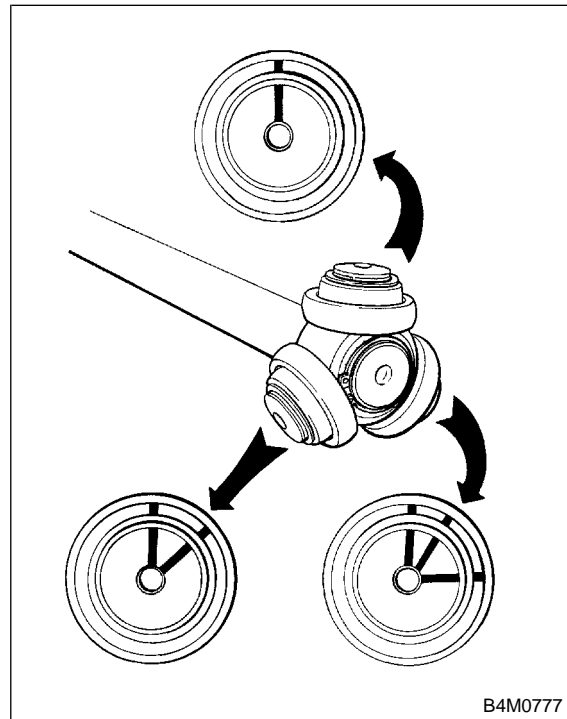

15) Align alignment marks on shaft and outer race, and install outer race.

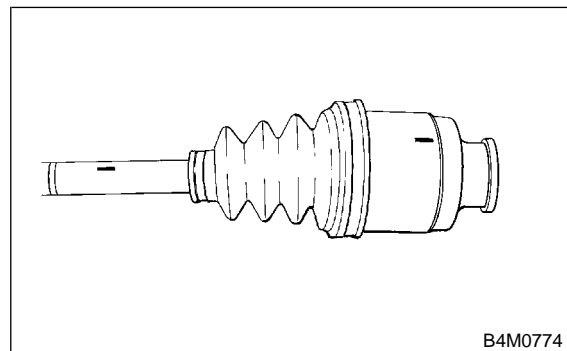

16) Install circlip in the groove on SFJ outer race.

**CAUTION:**  
**Pull the shaft lightly and assure that the circlip is completely fitted in the groove.**

## 3. Front and Rear Drive Shafts

17) Apply an even coat of the specified grease 30 to 40 g (1.06 to 1.41 oz) to the entire inner surface of boot.

18) Install SFJ boot taking care not to twist it.

**CAUTION:**

- The inside of the larger end of SFJ boot and the boot groove shall be cleaned so as to be free from grease and other substances.
- When installing SFJ boot, position outer race of SFJ at center of its travel.

19) Put a band through the clip and wind twice in alignment with band groove of boot.

**CAUTION:**

**Use a new band.**

20) Pinch the end of band with pliers. Hold the clip and tighten securely.

**NOTE:**

When tightening boot, exercise care so that the air within the boot is appropriate.

21) Tighten band by using ST.

ST 925091000 BAND TIGHTENING TOOL

**NOTE:**

Tighten band until it cannot be moved by hand.

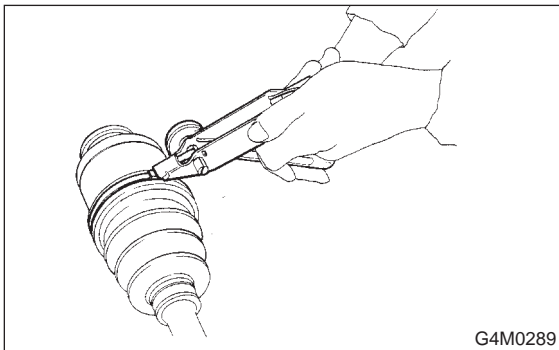

22) Tap on the clip with the punch provided at the end of ST.

ST 925091000 BAND TIGHTENING TOOL

**CAUTION:**

**Tap to an extent that the boot underneath is not damaged.**

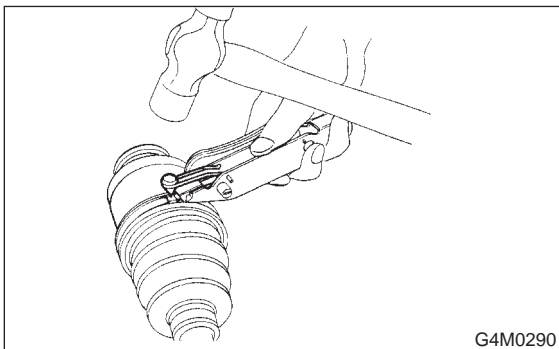

23) Cut off band with an allowance of about 10 mm (0.39 in) left from the clip and bend this allowance over the clip.

**CAUTION:**

**Be careful so that the end of the band is in close contact with clip.**

24) Fix up boot on BJ in the same manner.

**NOTE:**

Extend and retract SFJ to provide equal grease coating.

**2. REAR DRIVE SHAFT****CAUTION:**

**Use specified grease.**

**BJ side:**

**Molylex No. 2 (Part No. 723223010) or Sunlight TB2-A**

**DOJ side:**

**VU-3A702 (Yellow) (Part No. 23223GA050)**

1) Install BJ boot in specified position, and fill it with 60 to 70 g (2.12 to 2.47 oz) of specified grease.

2) Place DOJ boot at the center of shaft.

**CAUTION:**

**Be sure to wrap shaft splines with vinyl tape to prevent boot from scratches.**

3) Insert DOJ cage onto shaft.

**NOTE:**

Insert the cage with the cut-out portion facing the shaft end, since the cage has an orientation.

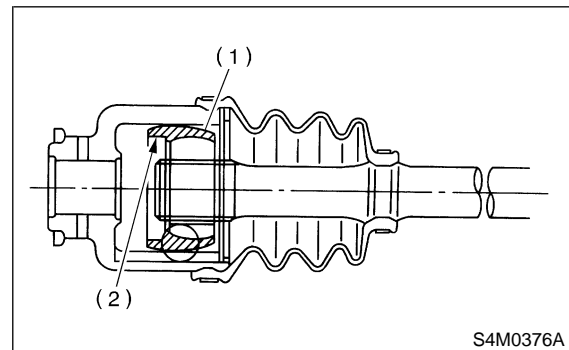

- (1) Cage
- (2) Cut-out portion

4) Install DOJ inner race on shaft and fit snap ring with pliers.

**NOTE:**

Confirm that the snap ring is completely fitted in the shaft groove.

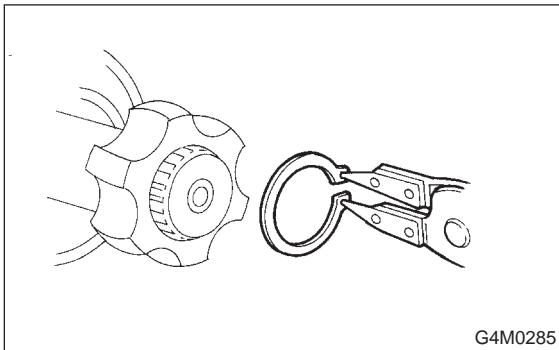

5) Install cage, which was previously fitted, to inner race fixed upon shaft.

**NOTE:**

Fit the cage with the protruded part aligned with the track on the inner race and then turn by a half pitch.

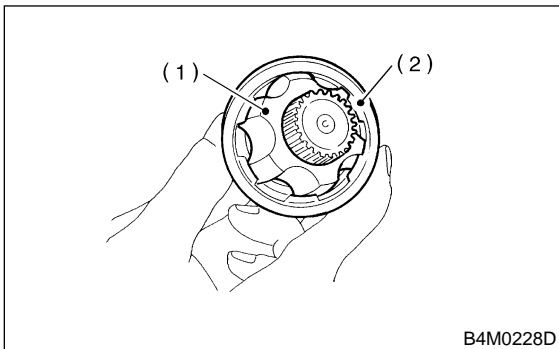

- (1) Inner race
- (2) Cage

6) Fill 80 to 90 g (2.82 to 3.17 oz) of specified grease into the interior of DOJ outer race.

7) Apply a coat of specified grease to the cage pocket and six balls.

8) Insert the six balls into the cage pocket.

9) Align the outer race track and ball positions and place in the part where shaft, inner race, cage and balls are previously installed, and then fit outer race.

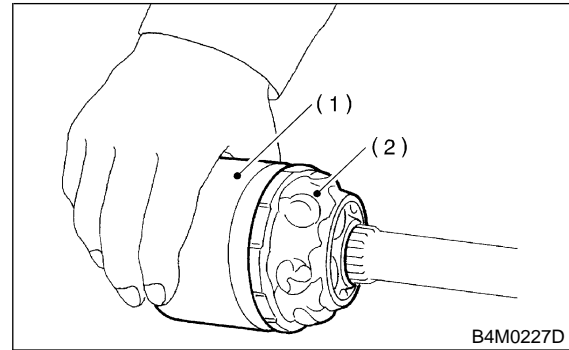

- (1) Outer race
- (2) Grease

10) Install circlip in the groove on DOJ outer race.

**NOTE:**

- Assure that the balls, cage and inner race are completely fitted in the outer race of DOJ.
- Exercise care not to place the matched position of circlip in the ball groove of outer race.
- Pull the shaft lightly and assure that the circlip is completely fitted in the groove.

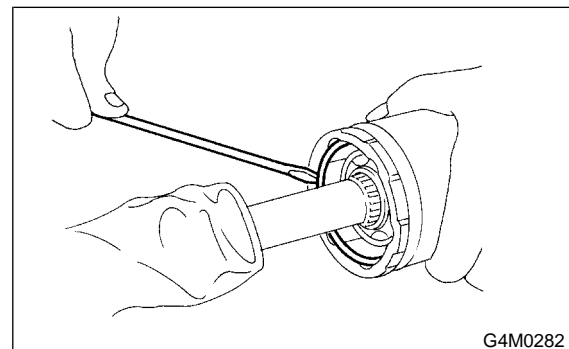

11) Apply an even coat of the specified grease [20 to 30 g (0.71 to 1.06 oz)] to the entire inner surface of boot. Also apply grease to shaft.

12) Install DOJ boot taking care not to twist it.

**NOTE:**

- The inside of the larger end of DOJ boot and the boot groove shall be cleaned so as to be free from grease and other substances.
- When installing DOJ boot, position outer race of DOJ at center of its travel.

13) Put a band through the clip and wind twice in alignment with band groove of boot.



## 3. Front and Rear Drive Shafts

**CAUTION:**

Use a new band.

14) Pinch the end of band with pliers. Hold the clip and tighten securely.

**NOTE:**

When tightening boot, exercise care so that the air within the boot is appropriate.

15) Tighten band by using ST.

ST 925091000 BAND TIGHTENING TOOL

**NOTE:**

Tighten band until it cannot be moved by hand.

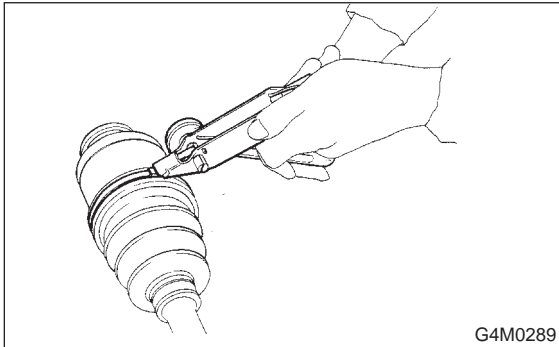

16) Tap on the clip with the punch provided at the end of ST.

ST 925091000 BAND TIGHTENING TOOL

**CAUTION:**

Tap to an extent that the boot underneath is not damaged.

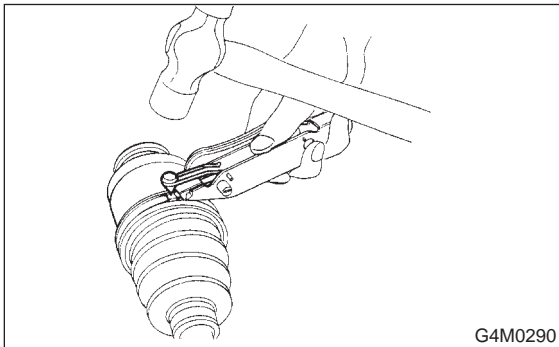

17) Cut off band with an allowance of about 10 mm (0.39 in) left from the clip and bend this allowance over the clip.

**CAUTION:**

Be careful so that the end of the band is in close contact with clip.

18) Fix up boot on BJ in the same manner.

**NOTE:**

Extend and retract DOJ to provide equal grease coating.

**E: INSTALLATION****1. FRONT DRIVE SHAFT**

1) Insert BJ into hub splines.

**CAUTION:**

Be careful not to damage inner oil seal lip.

2) Using ST1 and ST2, pull drive shaft into place.

ST1 922431000 AXLE SHAFT INSTALLER

ST2 927390000 ADAPTER

**CAUTION:**

Do not hammer drive shaft when installing it.

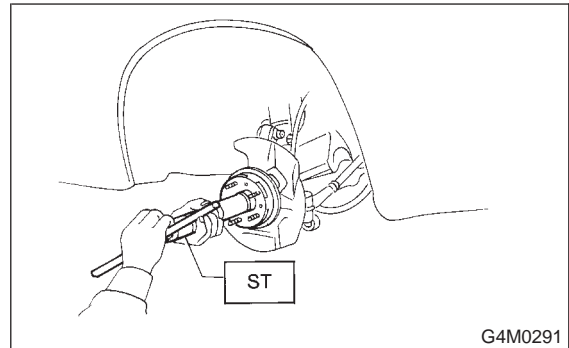

3) Tighten axle nut temporarily.

4) Install SFJ on transmission spindle and drive spring pin into place.

**CAUTION:**

Always use a new spring pin.

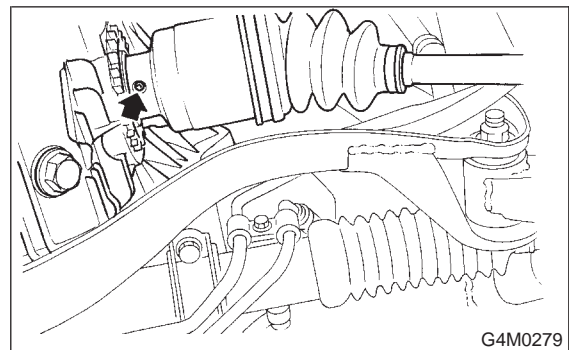

5) Connect transverse link to housing.

**Tightening torque (self-locking nut):**

**$49 \pm 10 \text{ N}\cdot\text{m}$  ( $5.0 \pm 1.0 \text{ kg}\cdot\text{m}$ ,  $36 \pm 7 \text{ ft}\cdot\text{lb}$ )**

**CAUTION:**

Use a new self-locking nut.

6) Install stabilizer bracket.

7) While depressing brake pedal, tighten axle nut to the specified torque.

**Tightening torque:**

**$186\pm 20$  N·m ( $19\pm 2$  kg·m,  $137\pm 14$  ft·lb)**

**CAUTION:**

- Use a new axle nut.
- Always tighten axle nut before installing wheel on vehicle. If wheel is installed and comes in contact with ground when axle nut is loose, wheel bearings may be damaged.
- Be sure to tighten axle nut to specified torque. Do not overtighten it as this may damage wheel bearing.

8) After tightening axle nut, lock it securely.

**2. REAR DRIVE SHAFT**

1) Insert BJ into rear housing splines.

**CAUTION:**

**Be careful not to damage inner oil seal lip.**

2) Using ST1 and ST2, pull drive shaft into place.

ST1 922431000 AXLE SHAFT INSTALLER

ST2 927390000 ADAPTER

**CAUTION:**

**Do not hammer drive shaft when installing it.**

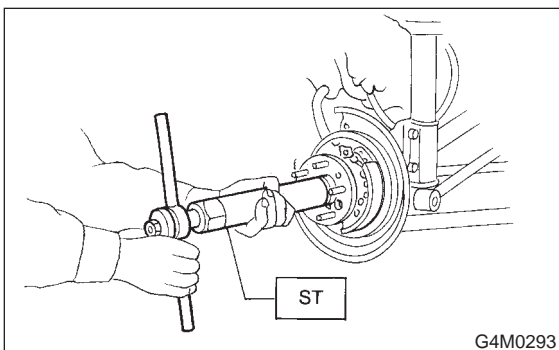

3) Tighten axle nut temporarily.

4) Using ST, install DOJ into differential.

ST 28099PA090 SIDE OIL SEAL PROTECTOR

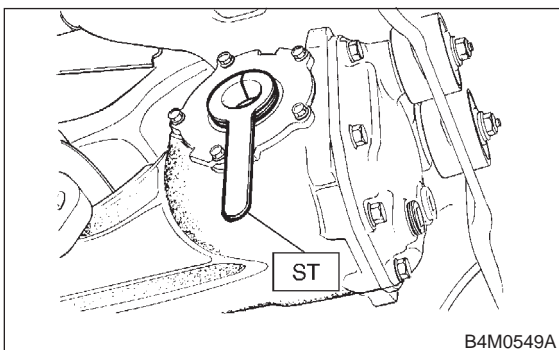

5) Insert DOJ spline end into bore of side oil seal, and remove ST.

**CAUTION:**

**Do not allow DOJ splines to damage side oil seal.**

ST 28099PA090 SIDE OIL SEAL PROTECTOR

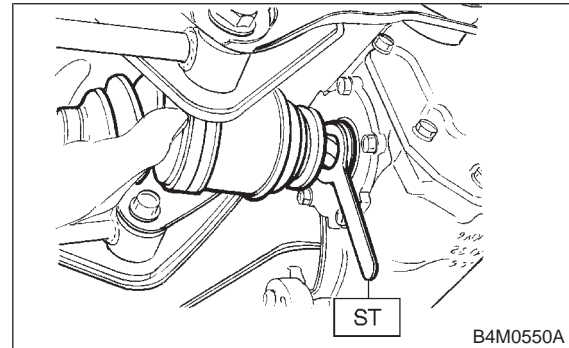

6) Align DOJ and differential splines.

7) Push housing to insert DOJ into differential.

**NOTE:**

Make sure DOJ is inserted properly.

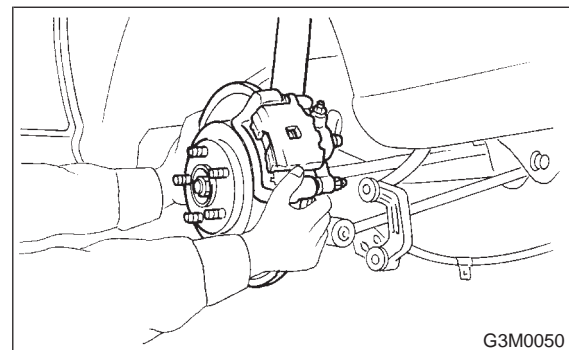

8) Connect rear housing assembly to trailing link assembly, and tighten self-locking nut.

**Tightening torque:**

**$113\pm 15$  N·m ( $11.5\pm 1.5$  kg·m,  $83\pm 11$  ft·lb)**

9) Connect rear housing assembly to lateral link assembly, and tighten self-locking nut.

**Tightening torque:**

**$137\pm 20$  N·m ( $14\pm 2$  kg·m,  $101\pm 14$  ft·lb)**

10) Install stabilizer bracket.

11) While depressing brake pedal, tighten axle nut using a socket wrench.

**Tightening torque:**

**$186\pm 20$  N·m ( $19\pm 2$  kg·m,  $137\pm 14$  ft·lb)**

**CAUTION:**

- Use a new axle nut.
- Always tighten axle nut before installing wheel on vehicle. If wheel is installed and comes in contact with ground when axle nut is loose, wheel bearings may be damaged.
- Be sure to tighten axle nut to specified torque. Do not overtighten it as this may damage wheel bearing.

12) After tightening axle nut, lock it securely.

## 4. Replacement of Front BJ and SFJ Boots

### A: REMOVAL

- 1) Disconnect ground cable from battery.
- 2) Jack-up vehicle, support it with safety stands (rigid rocks), and remove front wheel cap and wheels.

**NOTE:**

Do not remove axle nut.

- 3) Remove stabilizer link.
- 4) Disconnect transverse link from housing.
- 5) Remove spring pin which secures transmission spindle to SFJ.

**CAUTION:**

**Use a new spring pin.**

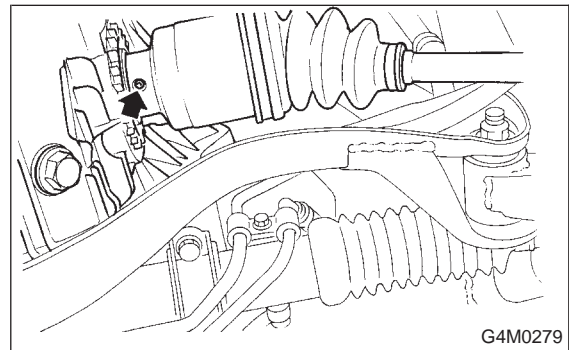

- 6) Remove BJ and SFJ boots from drive shaft. <Ref. to 4-2 [W3B1].>

### B: INSTALLATION

- 1) Install BJ and SFJ boots to drive shaft. <Ref. to 4-2 [W3D1].>
- 2) Install SFJ on transmission spindle and drive spring pin into place.

**CAUTION:**

**Always use a new spring pin.**

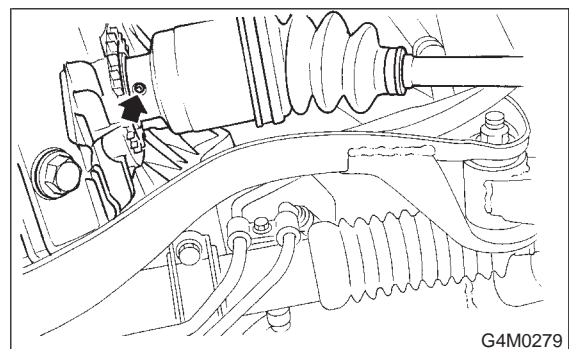

- 3) Connect transverse link to housing.
- 4) Install stabilizer link.

11) While depressing brake pedal, tighten axle nut using a socket wrench.

**Tightening torque:**

**$186\pm 20$  N·m ( $19\pm 2$  kg·m,  $137\pm 14$  ft·lb)**

**CAUTION:**

- Use a new axle nut.
- Always tighten axle nut before installing wheel on vehicle. If wheel is installed and comes in contact with ground when axle nut is loose, wheel bearings may be damaged.
- Be sure to tighten axle nut to specified torque. Do not overtighten it as this may damage wheel bearing.

12) After tightening axle nut, lock it securely.

## 4. Replacement of Front BJ and SFJ Boots

### A: REMOVAL

- 1) Disconnect ground cable from battery.
- 2) Jack-up vehicle, support it with safety stands (rigid rocks), and remove front wheel cap and wheels.

**NOTE:**

Do not remove axle nut.

- 3) Remove stabilizer link.
- 4) Disconnect transverse link from housing.
- 5) Remove spring pin which secures transmission spindle to SFJ.

**CAUTION:**

**Use a new spring pin.**

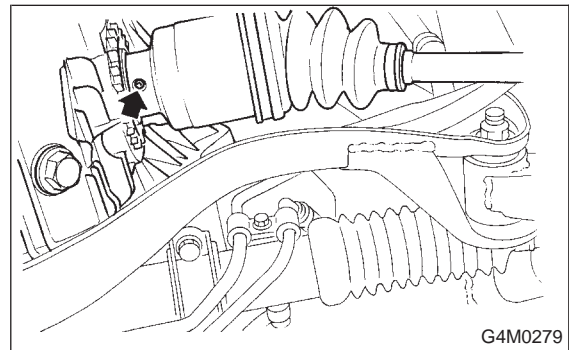

- 6) Remove BJ and SFJ boots from drive shaft. <Ref. to 4-2 [W3B1].>

### B: INSTALLATION

- 1) Install BJ and SFJ boots to drive shaft. <Ref. to 4-2 [W3D1].>
- 2) Install SFJ on transmission spindle and drive spring pin into place.

**CAUTION:**

**Always use a new spring pin.**

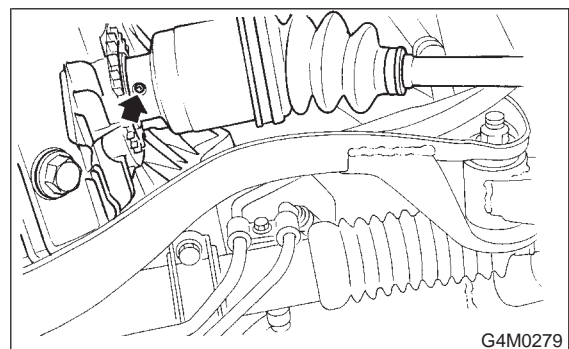

- 3) Connect transverse link to housing.
- 4) Install stabilizer link.

## 5. Replacement of Rear DOJ and BJ Boots

### A: REMOVAL

- 1) Disconnect ground cable from battery.
- 2) Lift-up vehicle, and remove rear wheel cap and wheels.

**NOTE:**

Axle nut need not be removed.

- 3) Remove ABS sensor clamps and parking brake cable bracket.
  - 4) Disconnect stabilizer link from lateral link.
  - 5) Remove bolts which secure lateral link assembly to rear housing.
  - 6) Remove bolts which secure trailing link assembly to rear housing.
  - 7) Remove DOJ from rear differential using ST.
- ST 28099PA100 DRIVE SHAFT REMOVER

**NOTE:**

The side spline shaft circlip comes out together with the shaft.

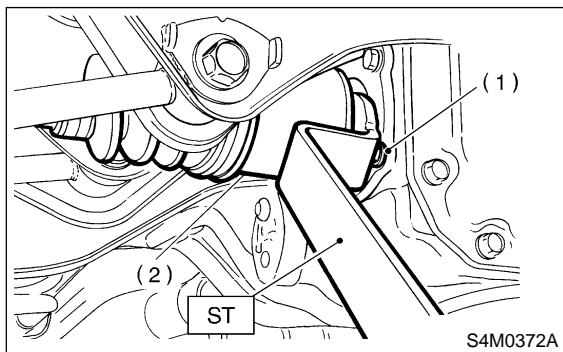

- (1) Bolt
- (2) DOJ

**CAUTION:**

Be careful not to damage side bearing retainer. Always use bolt as shown in figure, as supporting point for ST during removal.

ST 28099PA100 DRIVE SHAFT REMOVER

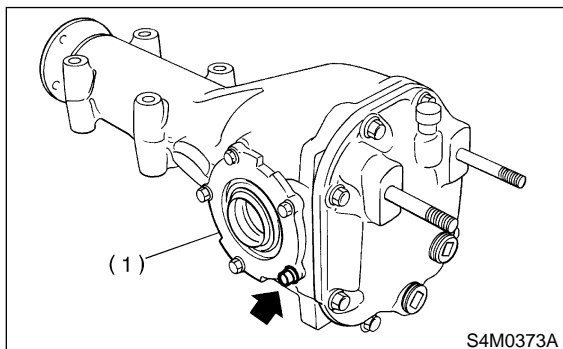

- (1) Side bearing retainer

- 8) Remove DOJ and BJ boots from drive shaft. <Ref. to 4-2 [W3B2].>

### B: INSTALLATION

- 1) Install DOJ and BJ boots to drive shaft. <Ref. to 4-2 [W3D2].>

- 2) Using ST, install DOJ into differential.

ST 28099PA090 SIDE OIL SEAL PROTECTOR

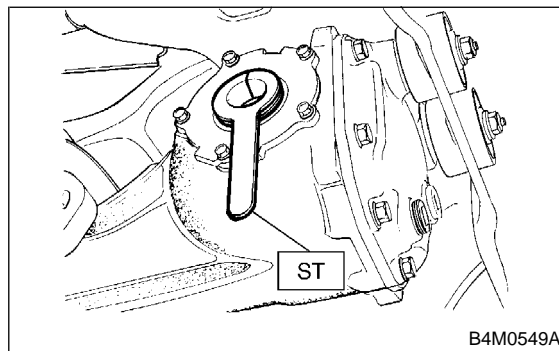

- 3) Insert DOJ spline end into bore of side oil seal, and remove ST.

**CAUTION:**

Do not allow DOJ splines to damage side oil seal.

ST 28099PA090 SIDE OIL SEAL PROTECTOR

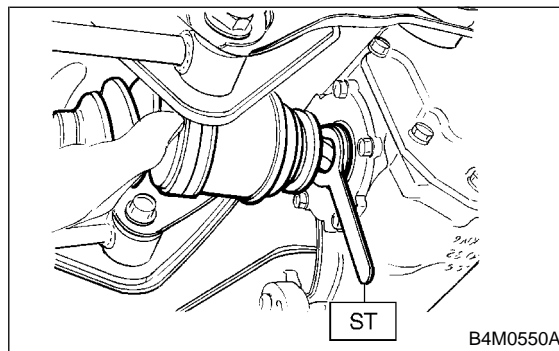

- 4) Align DOJ and differential splines.
- 5) Push housing to insert DOJ into differential.

**NOTE:**

Make sure DOJ is inserted properly.

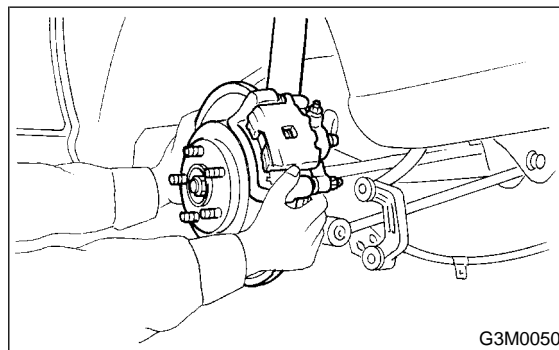

**CAUTION:**

Discard old self-locking nut. Replace with a new one.

- 6) Connect rear housing assembly to trailing link assembly, and tighten self-locking nut.
- 7) Connect rear housing assembly to lateral link assembly, and tighten self-locking nut.
- 8) Connect stabilizer link to lateral link.
- 9) Install ABS sensor clamps and parking brake cable bracket.

**6. Steel Wheel and Tire**

**A: INSPECTION**

- 1) Deformation or damage on the rim can cause air leakage. Check the rim flange for deformation, crack, or damage, and repair or replace as necessary.
- 2) Take stone, glass, nail etc. off the tread groove.
- 3) Replace tire:

**CAUTION:**

- When replacing a tire, make sure to use only the same size, construction and load range as originally installed.
- Avoid mixing radial, belted bias or bias tires on the vehicle.

- (1) when large crack on side wall, damage or crack on tread is found.
- (2) when the "tread wear indicator" appears as a solid band across the tread.

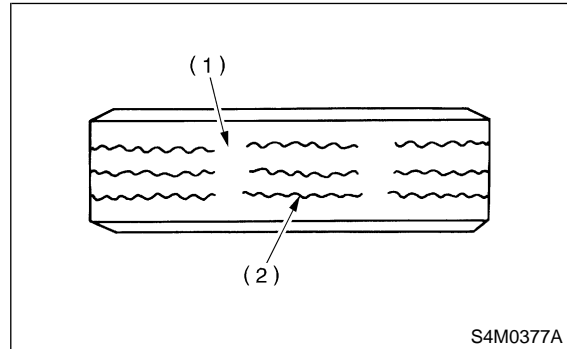

- (1) Tread wear indicator
- (2) Tire tread

**1. INSPECTION OF WHEEL RUNOUT**

- 1) Jack-up vehicle until wheels clear the floor.
- 2) Slowly rotate wheel to check rim "runout" using a dial gauge.

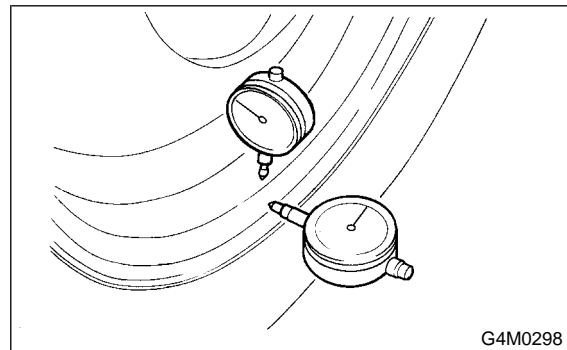

	Axial runout limit	Radial runout limit
Steel wheel	1.5 mm (0.059 in)	
Aluminum wheel	1.0 mm (0.039 in)	

**CAUTION:**

Discard old self-locking nut. Replace with a new one.

- 6) Connect rear housing assembly to trailing link assembly, and tighten self-locking nut.
- 7) Connect rear housing assembly to lateral link assembly, and tighten self-locking nut.
- 8) Connect stabilizer link to lateral link.
- 9) Install ABS sensor clamps and parking brake cable bracket.

## 6. Steel Wheel and Tire

### A: INSPECTION

- 1) Deformation or damage on the rim can cause air leakage. Check the rim flange for deformation, crack, or damage, and repair or replace as necessary.
- 2) Take stone, glass, nail etc. off the tread groove.
- 3) Replace tire:

**CAUTION:**

- When replacing a tire, make sure to use only the same size, construction and load range as originally installed.
- Avoid mixing radial, belted bias or bias tires on the vehicle.

- (1) when large crack on side wall, damage or crack on tread is found.
- (2) when the “tread wear indicator” appears as a solid band across the tread.

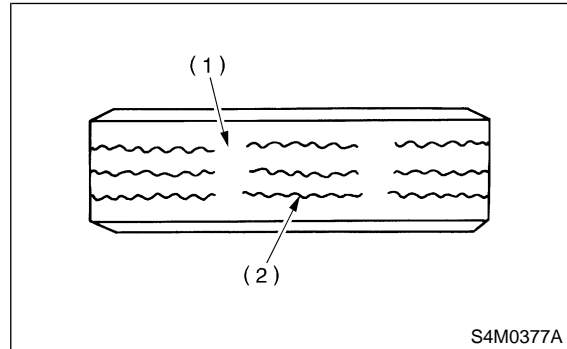

- (1) Tread wear indicator
- (2) Tire tread

### 1. INSPECTION OF WHEEL RUNOUT

- 1) Jack-up vehicle until wheels clear the floor.
- 2) Slowly rotate wheel to check rim “runout” using a dial gauge.

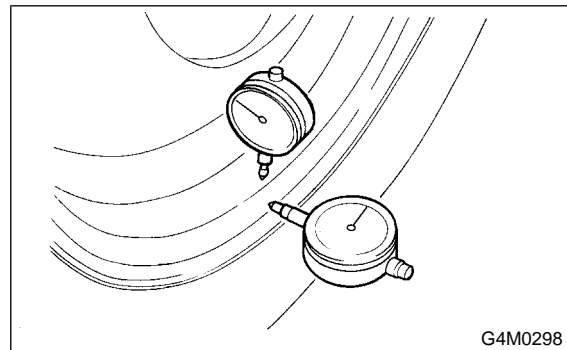

	Axial runout limit	Radial runout limit
Steel wheel	1.5 mm (0.059 in)	
Aluminum wheel	1.0 mm (0.039 in)	

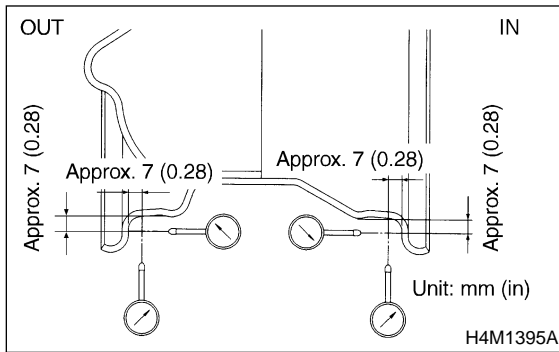

- 3) If rim runout exceeds specifications, remove tire from rim and check runout while attaching dial gauge to positions shown in figure.
- 4) If measured runout still exceeds specifications, replace the wheel.

## 7. Aluminum Wheel

### A: INSPECTION

Inspection for aluminum wheels is basically the same as the one for steel wheels. However, check the rim flange for cracks or damage, and replace (not repair) aluminum wheel if air leakage is found.

### B: PRECAUTIONS

Aluminum wheels are easily scratched. To maintain their appearance and safety, do the following:

- 1) Do not damage aluminum wheels during removal, disassembly, installation, wheel balancing, etc. After removing aluminum wheels, place them on a rubber mat, etc.
- 2) While vehicle is being driven, be careful not to ride over sharp obstacles or allow aluminum wheels to contact the shoulder of the road.
- 3) When installing tire chain, be sure to install it properly not to have a slack; otherwise it may hit wheel while driving.
- 4) When washing aluminum wheel, use neutral synthetic detergent and water. Avoid using the cleanser including abrasive, hard brushes or an automatic car washer.



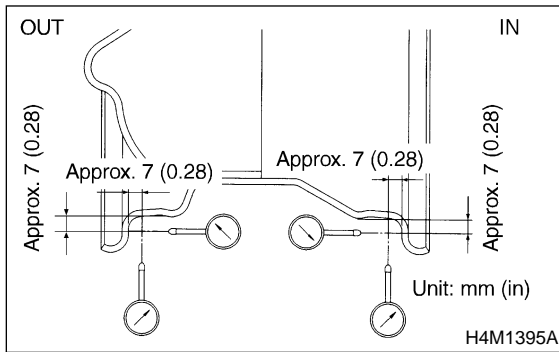

- 3) If rim runout exceeds specifications, remove tire from rim and check runout while attaching dial gauge to positions shown in figure.
- 4) If measured runout still exceeds specifications, replace the wheel.

## 7. Aluminum Wheel

### A: INSPECTION

Inspection for aluminum wheels is basically the same as the one for steel wheels. However, check the rim flange for cracks or damage, and replace (not repair) aluminum wheel if air leakage is found.

### B: PRECAUTIONS

Aluminum wheels are easily scratched. To maintain their appearance and safety, do the following:

- 1) Do not damage aluminum wheels during removal, disassembly, installation, wheel balancing, etc. After removing aluminum wheels, place them on a rubber mat, etc.
- 2) While vehicle is being driven, be careful not to ride over sharp obstacles or allow aluminum wheels to contact the shoulder of the road.
- 3) When installing tire chain, be sure to install it properly not to have a slack; otherwise it may hit wheel while driving.
- 4) When washing aluminum wheel, use neutral synthetic detergent and water. Avoid using the cleanser including abrasive, hard brushes or an automatic car washer.

## 8. Wheel Balancing

- 1) Proper wheel balance may be lost if the tire is repaired or if it wears. Check the tire for dynamic balance, and repair as necessary.
- 2) To check for dynamic balance, use a dynamic balancer. Drive in the balance weight on both the top and rear sides of the rim.
- 3) Some types of balancer can cause damage to the wheel. Use an appropriate balancer when adjusting the wheel balance.
- 4) Use genuine balance weights.

### CAUTION:

- 55 g (1.94 oz) weight used with aluminum wheel is not available.
- Balance weights are available for use with any of 14- to 16-inch wheels.

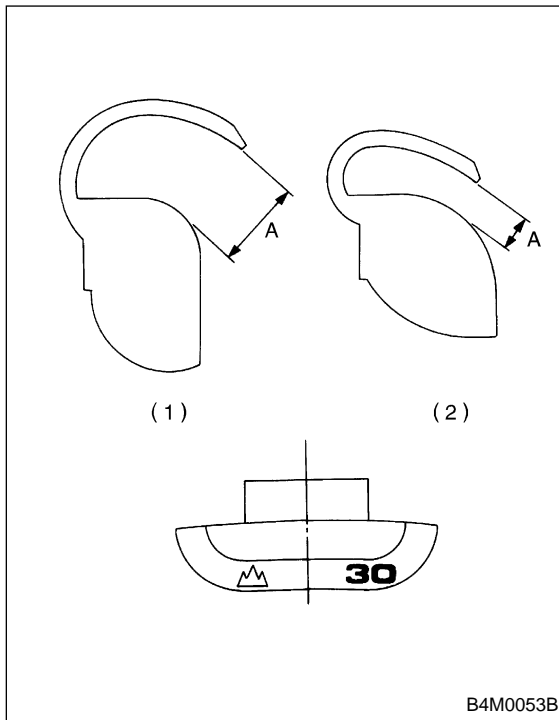

- (1) Weight for aluminum wheel
- (2) Weight for steel wheel

### Service limit: A

#### Weight for steel wheel;

1.8 — 2.0 mm (0.071 — 0.079 in)

#### Weight for aluminum wheel;

4.5 mm (0.177 in)

## 9. Installation of Wheel Assembly to Vehicle

- 1) Attach the wheel to the hub by aligning the wheel bolt hole with the hub bolt.
- 2) Temporarily attach the wheel nuts to the hub bolts. (In the case of aluminum wheel, use SUBARU genuine wheel nut for aluminum wheel.)
- 3) Manually tighten the nuts making sure the wheel hub hole is aligned correctly to the guide portion of hub.
- 4) Tighten the wheel nuts in a diagonal selection to the specified torque. Use a wheel nut wrench.

### Wheel nut tightening torque:

$88 \pm 10 \text{ N}\cdot\text{m}$  ( $9 \pm 1 \text{ kg}\cdot\text{m}$ ,  $65 \pm 7 \text{ ft}\cdot\text{lb}$ )

### CAUTION:

- Tighten the wheel nuts in two or three steps by gradually increasing the torque and working diagonally, until the specified torque is reached. For drum brake models, excess tightening of wheel nuts may cause wheels to “judder”.
  - Do not depress the wrench with a foot; Always use both hands when tightening.
  - Make sure the bolt, nut and the nut seating surface of the wheel are free from oils.
- 5) If a wheel is removed for replacement or for repair of a puncture, retighten the wheel nuts to the specified torque after running 1,000 km (600 miles).

## 8. Wheel Balancing

- 1) Proper wheel balance may be lost if the tire is repaired or if it wears. Check the tire for dynamic balance, and repair as necessary.
- 2) To check for dynamic balance, use a dynamic balancer. Drive in the balance weight on both the top and rear sides of the rim.
- 3) Some types of balancer can cause damage to the wheel. Use an appropriate balancer when adjusting the wheel balance.
- 4) Use genuine balance weights.

### CAUTION:

- 55 g (1.94 oz) weight used with aluminum wheel is not available.
- Balance weights are available for use with any of 14- to 16-inch wheels.

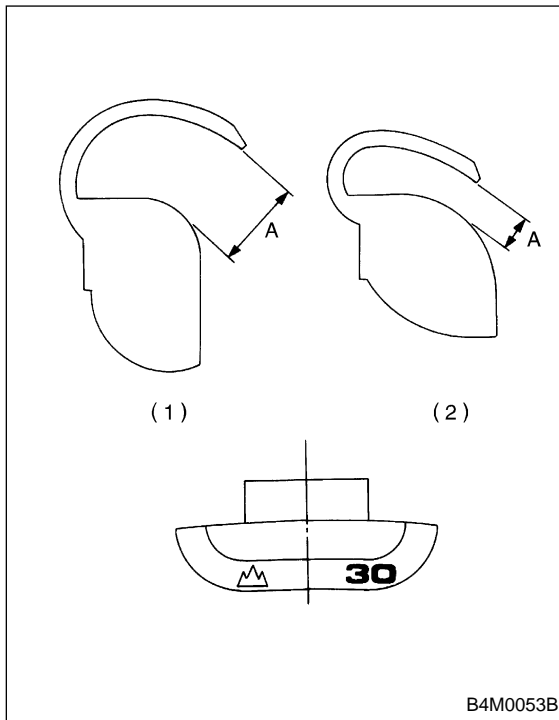

- (1) Weight for aluminum wheel
- (2) Weight for steel wheel

### Service limit: A

#### Weight for steel wheel;

1.8 — 2.0 mm (0.071 — 0.079 in)

#### Weight for aluminum wheel;

4.5 mm (0.177 in)

## 9. Installation of Wheel Assembly to Vehicle

- 1) Attach the wheel to the hub by aligning the wheel bolt hole with the hub bolt.
- 2) Temporarily attach the wheel nuts to the hub bolts. (In the case of aluminum wheel, use SUBARU genuine wheel nut for aluminum wheel.)
- 3) Manually tighten the nuts making sure the wheel hub hole is aligned correctly to the guide portion of hub.
- 4) Tighten the wheel nuts in a diagonal selection to the specified torque. Use a wheel nut wrench.

### Wheel nut tightening torque:

$88 \pm 10$  N-m ( $9 \pm 1$  kg-m,  $65 \pm 7$  ft-lb)

### CAUTION:

- Tighten the wheel nuts in two or three steps by gradually increasing the torque and working diagonally, until the specified torque is reached. For drum brake models, excess tightening of wheel nuts may cause wheels to “judder”.
  - Do not depress the wrench with a foot; Always use both hands when tightening.
  - Make sure the bolt, nut and the nut seating surface of the wheel are free from oils.
- 5) If a wheel is removed for replacement or for repair of a puncture, retighten the wheel nuts to the specified torque after running 1,000 km (600 miles).

## 10. Tire Rotation

If tires are maintained at the same positions for a long period of time, uneven wear results. Therefore, they should be periodically rotated. This lengthens service life of tires.

**CAUTION:**

**When rotating tires, replace unevenly worn or damaged tires with new ones.**

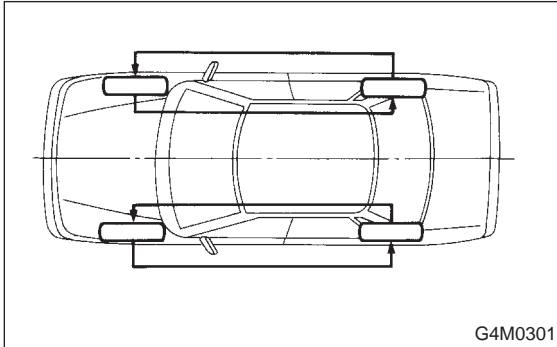

MEMO:

## 1. Steering System

### A: SPECIFICATIONS

Whole system	Minimum turning radius		m (ft)	5.4 (17.7)
	Steering angle (Inside-Outside)			34.4°±1.5° — 30.2°±1.5°
	Steering wheel diameter		mm (in)	385 (15.16)
	Overall gear ratio (Turns, lock to lock)			19.0 (3.4)
Gearbox	Type			Rack and pinion, Integral
	Backlash			0 (Automatically adjustable)
	Valve (Power steering system)			Rotary valve
Pump (Power steering system)	Type			Vane pump
	Oil tank			Installed on pump
	Output		cm <sup>3</sup> (cu in)/rev.	7.2 — 0.6 (0.439 — 0.037)
	Relief pressure		kPa (kg/cm <sup>2</sup> , psi)	7,355 (75, 1,067)
	Hydraulic fluid control			Drooping in response to increased engine revolutions
	Hydraulic fluid		ℓ (US qt, Imp qt)	1,000 rpm: 7 (7.4, 6.2) 3,000 rpm: 5 (5.3, 4.4)
	Range of revolution		rpm	500 — 7,500
Working fluid (Power steering system)	Revolving direction			Clockwise
	Name			ATF DEXRON IIE or III
	Capacity	Oil tank	ℓ (US qt, Imp qt)	0.3 (0.3, 0.3)
		Total	ℓ (US qt, Imp qt)	0.7 (0.7, 0.6)

### B: SERVICE DATA

Steering wheel	Free play		mm (in)	17 (0.67)
Turning angle	Inner tire & wheel			34.4°±1.5°
	Outer tire & wheel			30.2°±1.5°
Steering shaft	Clearance between steering wheel and column cover		mm (in)	3.0 (0.118)
Steering gearbox (Power steering system)	Sliding resistance		N (kg, lb)	304.0 (31.0, 68.4) or less
	Rack shaft play in radial direction	Right-turn steering	mm (in)	0.15 (0.0059) or less
		Left-turn steering	mm (in)	Horizontal movement: 0.3 (0.012) or less Vertical movement: 0.15 (0.0059) or less
	Input shaft play	In radial direction	mm (in)	0.18 (0.0071) or less
		In axial direction	mm (in)	0.1 (0.004) or less
Turning resistance		N (kg, lb)	Within 30 mm (1.18 in) from rack center in straight ahead position: Less than 11.18 (1.14, 2.51) Maximum allowable value: 12.7 (1.3, 2.9)	
Oil pump (Power steering system)	Pulley shaft	Radial play	mm (in)	0.4 (0.016) or less
		Axial play	mm (in)	0.9 (0.035) or less
	Pulley	Ditch deflection	mm (in)	1.0 (0.039) or less
		Resistance to rotation	N (kg, lb)	9.22 (0.94, 2.07) or less
	Regular pressure		kPa (kg/cm <sup>2</sup> , psi)	981 (10, 142) or less
Relief pressure		kPa (kg/cm <sup>2</sup> , psi)	7,355 (75, 1,067)	
Steering wheel effort (Power steering system)	At standstill with engine idling on a concrete road		N (kg, lb)	29.4 (3.0, 6.6) or less
	At standstill with engine stalled on a concrete road		N (kg, lb)	294.2 (30, 66.2) or less

**C: RECOMMENDED POWER  
STEERING FLUID**

Recommended power steering fluid	Manufacturer
ATF DEXRON IIE or III	B.P.
	CALTEX
	CASTROL
	MOBIL
	SHELL
	TEXACO

**MEMO:**



1. Steering Wheel and Column

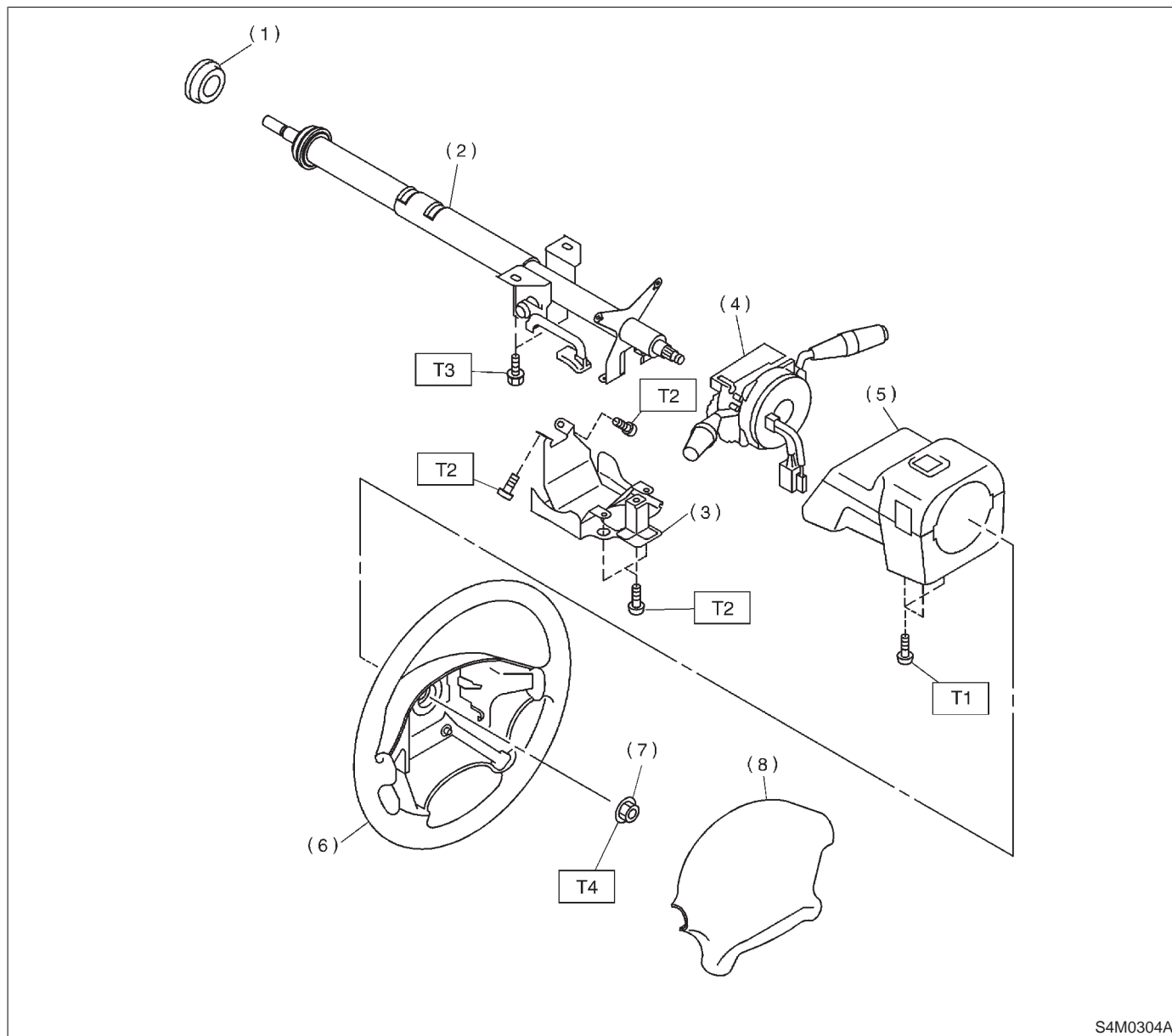

S4M0304A

- (1) Bushing
- (2) Steering shaft
- (3) Knee protector
- (4) Steering roll connector
- (5) Column cover

- (6) Steering wheel
- (7) Flange nut
- (8) Airbag module

**Tightening torque: N-m (kg-m, ft-lb)**

**T1: 1.2±0.2 (0.12±0.02, 0.9±0.1)**

**T2: 3.4±1.0 (0.35±0.1, 2.5±0.7)**

**T3: 25±5 (2.5±0.5, 18.1±3.6)**

**T4: 44±5 (4.5±0.5, 32.5±3.6)**

## 2. Power Steering System

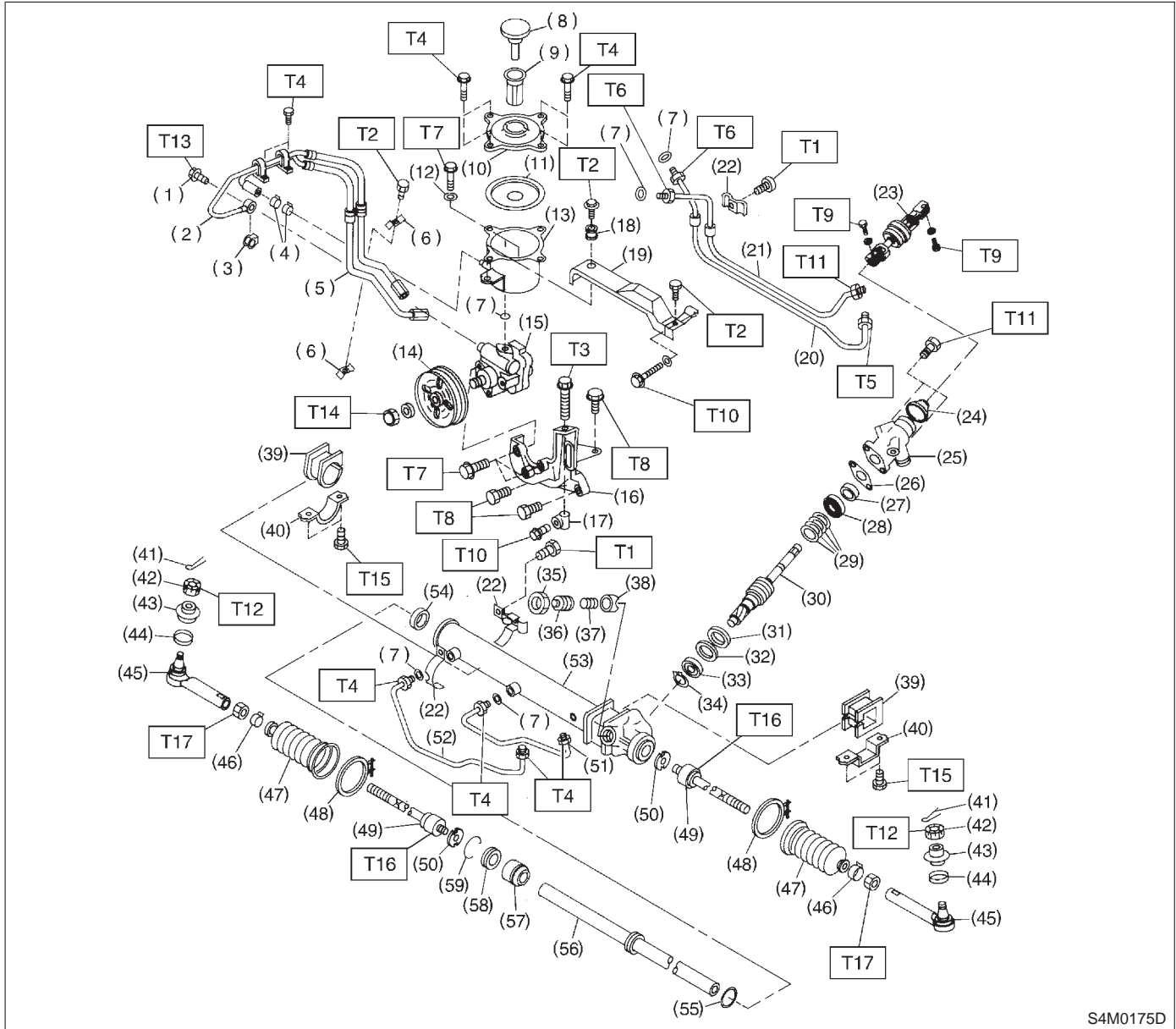

S4M0175D

(1) Eye bolt	(28) Special bearing	(55) Piston ring
(2) Pipe C	(29) Seal ring	(56) Rack
(3) Gasket	(30) Pinion and valve ASSY	(57) Rack bushing
(4) Clip	(31) Oil seal	(58) Rack stopper
(5) Pipe D	(32) Back-up washer	(59) Circlip
(6) Clamp E	(33) Ball bearing	
(7) O-ring	(34) Snap ring	
(8) Cap	(35) Lock nut	
(9) Strainer	(36) Adjusting screw	
(10) Upper shell	(37) Spring	
(11) Baffle	(38) Sleeve	
(12) Seal washer	(39) Adapter	
(13) Lower shell	(40) Clamp	
(14) Pulley	(41) Cotter pin	
(15) Oil pump	(42) Castle nut	
(16) Bracket	(43) Dust seal	
(17) Belt tension nut	(44) Clip	
(18) Bush	(45) Tie-rod end	
(19) Belt cover	(46) Clip	
(20) Pipe E	(47) Boot	
(21) Pipe F	(48) Band	
(22) Clamp plate	(49) Tie-rod	
(23) Universal joint	(50) Lock washer	
(24) Dust cover	(51) Pipe B	
(25) Valve housing	(52) Pipe A	
(26) Gasket	(53) Housing ASSY	
(27) Oil seal	(54) Oil seal	

---

**Tightening torque: N-m (kg-m, ft-lb)**

**T1: 6±1 (0.6±0.1, 4.3±0.7)**

**T2: 7.4±2.0 (0.75±0.20, 5.4±1.4)**

**T3: 8±2 (0.8±0.2, 5.8±1.4)**

**T4: 13±3 (1.3±0.3, 9.4±2.2)**

**T5: 15±3 (1.5±0.3, 10.8±2.2)**

**T6: 15±5 (1.5±0.5, 10.8±3.6)**

**T7: 18<sup>+5</sup>/<sub>0</sub> (1.8<sup>+0.5</sup>/<sub>0</sub>, 13.0<sup>+3.6</sup>/<sub>0</sub>)**

**T8: 22±2 (2.2±0.2, 15.9±1.4)**

**T9: 24±3 (2.4±0.3, 17.4±2.2)**

**T10: 25±2 (2.5±0.2, 18.1±1.4)**

**T11: 25±5 (2.5±0.5, 18.1±3.6)**

**T12: 27.0±2.5 (2.75±0.25, 19.9±1.8)**

**T13: 39±5 (4.0±0.5, 28.9±3.6)**

**T14: 52±10 (5.3±1.0, 38±7)**

**T15: 59±12 (6.0±1.2, 43±9)**

**T16: 78±10 (8.0±1.0, 58±7)**

**T17: 83±5 (8.5±0.5, 61.5±3.6)**

---

## 1. Supplemental Restraint System "Airbag" AIRBAG

### A: PRECAUTION

Airbag system wiring harness is routed near the steering wheel, steering shaft and column.

#### WARNING:

- All airbag system wiring harness and connectors are yellow. Do not use electrical test equipment on these circuit.
- Be careful not to damage airbag system wiring harness when servicing the steering wheel, steering shaft and column.

## 2. Tilt Steering Column

### A: REMOVAL

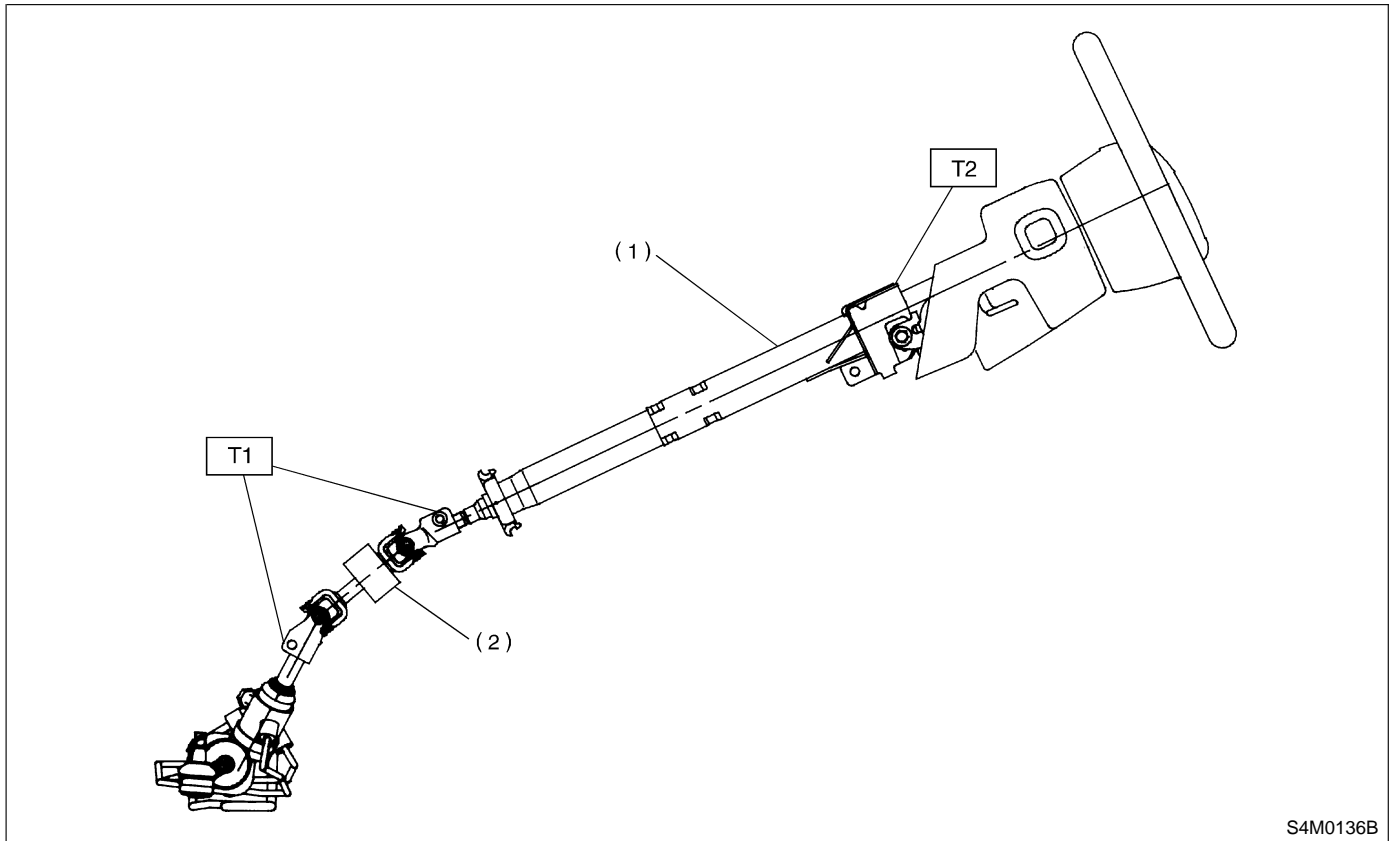

S4M0136B

- (1) Tilt steering column
- (2) Universal joint

**Tightening torque: N-m (kg-m, ft-lb)**

**T1: 24±3 (2.4±0.3, 17.4±2.2)**

**T2: 25±5 (2.5±0.5, 18.1±3.6)**

- 1) Disconnect battery minus terminal.
- 2) Lift-up vehicle.
- 3) Remove airbag module. <Ref. to 5-5 [W3A1].>

**WARNING:**

Always refer to “5-5 Supplemental Restraint System” before performing airbag module service (if so equipped). <Ref. to 5-5 [W1A0].>

- 4) Remove steering wheel nut, then draw out steering wheel from shaft using steering puller.

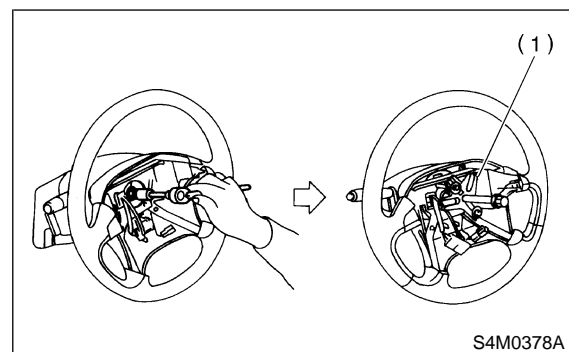

S4M0378A

- (1) Steering puller

5) Remove universal joint bolts and then remove universal joint.

**CAUTION:**

**Scribe alignment marks on universal joint so that it can be reassembled at the original ser-  
ration.**

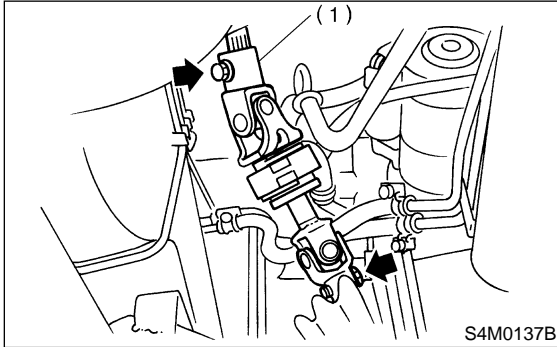

(1) Universal joint

6) Remove trim panel under instrument panel.

7) Remove knee bolster.

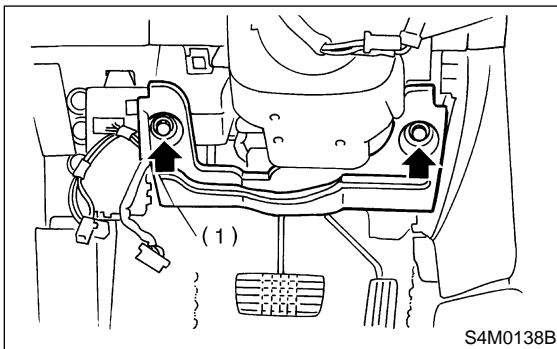

(1) Knee bolster

8) Disconnect connectors for ignition switch and combination switch wiring harness under instrument panel.

9) Remove the two bolts under instrument panel securing steering column.

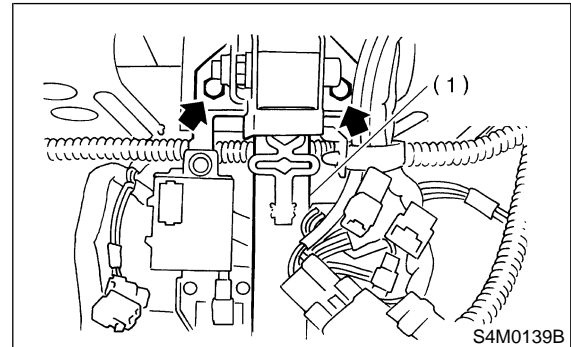

(1) Steering column

10) Pull out steering shaft assembly from hole on toe board.

**CAUTION:**

**Be sure to remove universal joint before removing steering shaft assembly installing bolts when removing steering shaft assembly or when lowering it for servicing of other parts.**

**B: DISASSEMBLY**

1) Remove the three screws securing upper and lower steering column covers, and the two screws securing combination switch, then remove related parts.

**C: INSPECTION**

**1. BASIC INSPECTION**

Clean the disassembled parts with a cloth, and check for wear, damage, or any other faults. If necessary, repair or replace faulty parts.

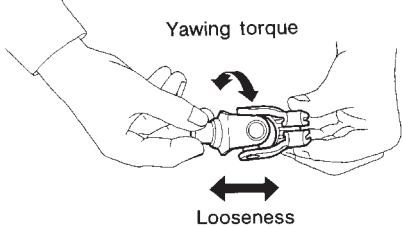
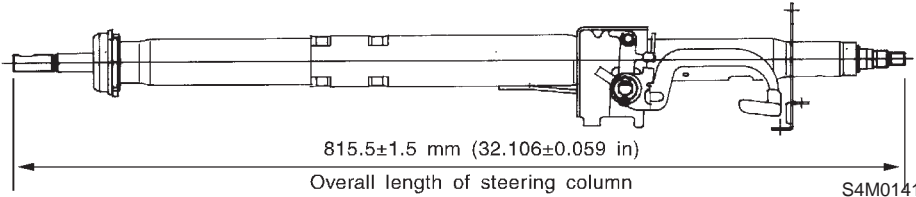
Part name	Inspection	Corrective action
Universal joint	<ul style="list-style-type: none"> <li>● Free play</li> <li>● Swinging torque</li> </ul> Yawing torque Looseness  <p style="text-align: right;">G4M0089</p> <p><b>Standard value of universal joint free play: 0 mm (0 in)</b>  <b>Max. value of universal joint swinging torque: 0.3 N·m (0.03 kg·m, 0.2 ft·lb)</b></p>	Replace if faulty.
Steering column	<ul style="list-style-type: none"> <li>● Overall length of steering column</li> </ul> Measure overall length of steering column. Standard overall length of steering column:  <p style="text-align: right;">S4M0141A</p>	Replace steering column assembly.

**2. AIRBAG MODEL INSPECTION**

**WARNING:**

For airbag model inspection procedures, refer to 5-5 Supplemental Restraint System. <Ref. to 5-5 [W2F0].> and <Ref. to 5-5 [W2G0].>

**D: ASSEMBLY**

- 1) Insert combination switch to upper column shaft, and install lower column cover with tilt lever held in the lowered position. Then route ignition key harness and combination switch harness between column cover mounting bosses.
- 2) Fit upper column cover to lower column cover, and tighten combination switch and column cover.

**Tightening torque:**

**1.2±0.2 N·m (0.12±0.02 kg·m, 0.9±0.1 ft·lb)**

**CAUTION:**

**Don't overtorque screw.**

**E: INSTALLATION**

- 1) Insert end of steering shaft into toe board grommet.
- 2) Tighten steering shaft mounting bolts under instrument panel.

**Tightening torque:**

**$25 \pm 5 \text{ N}\cdot\text{m}$  ( $2.5 \pm 0.5 \text{ kg}\cdot\text{m}$ ,  $18.1 \pm 3.6 \text{ ft}\cdot\text{lb}$ )**

- 3) Connect ignition and combination switch connectors under instrument panel.
- 4) Connect airbag system connector at harness spool.

**NOTE:**

Make sure to apply double lock.

- 5) Install universal joint.
  - (1) Align bolt hole on the long yoke side of universal joint with the cutout at the serrated section of shaft end, and insert universal joint.
  - (2) Align bolt hole on the short yoke side of universal joint with the cutout at the serrated section of gearbox assembly. Lower universal joint completely.
  - (3) Temporarily tighten bolt on the short yoke side. Raise universal joint to make sure the bolt is properly passing through the cutout at the serrated section.
  - (4) Tighten bolt on the long yoke side, then that on the short yoke side.

**Tightening torque:**

**$24 \pm 3 \text{ N}\cdot\text{m}$  ( $2.4 \pm 0.3 \text{ kg}\cdot\text{m}$ ,  $17.4 \pm 2.2 \text{ ft}\cdot\text{lb}$ )**

**CAUTION:**

- Make sure that universal joint bolts is tightened through notch in shaft serration.
- Excessively large tightening torque of universal joint bolts may lead to heavy steering wheel operation.

**Standard clearance between gearbox to DOJ:**

**Over 15 mm (0.59 in)**

- 6) Install knee bolster.

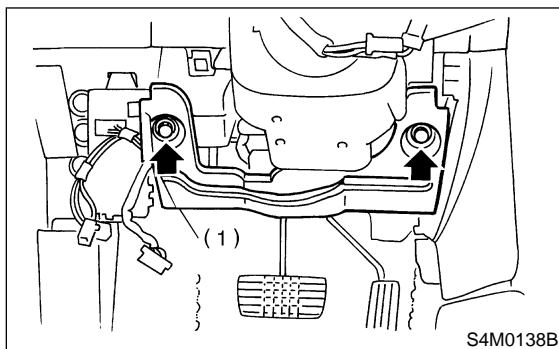

(1) Knee bolster

- 7) Align center of roll connector. <Ref. to 5-5 [W8B1].>

**CAUTION:**

Ensure that front wheels are set in straight forward direction.

- 8) Set steering wheel to neutral and install it onto steering shaft.

**Tightening torque:**

**$44 \pm 5 \text{ N}\cdot\text{m}$  ( $4.5 \pm 0.5 \text{ kg}\cdot\text{m}$ ,  $32.5 \pm 3.6 \text{ ft}\cdot\text{lb}$ )**

**Column cover-to-steering wheel clearance:**

**2 — 4 mm (0.08 — 0.16 in)**

**CAUTION:**

Insert roll connector guide pin into guide hole on lower end of surface of steering wheel to prevent damage. Draw out airbag system connector, horn connector and cruise control connectors from guide hole of steering wheel lower end.

- 9) Install airbag module to steering wheel.

**WARNING:**

Always refer to 5-5 Supplemental Restraint System before performing the service operation. <Ref. to 5-5 [W3A0].>



### 3. Steering Gearbox (Power Steering System)

#### A: REMOVAL

**NOTE:**

For disassembly and assembly of gearbox unit, refer to section Control Valve (Power Steering Gearbox).  
 <Ref. to 4-3 [W4B0].> and <Ref. to 4-3 [W4D0].>

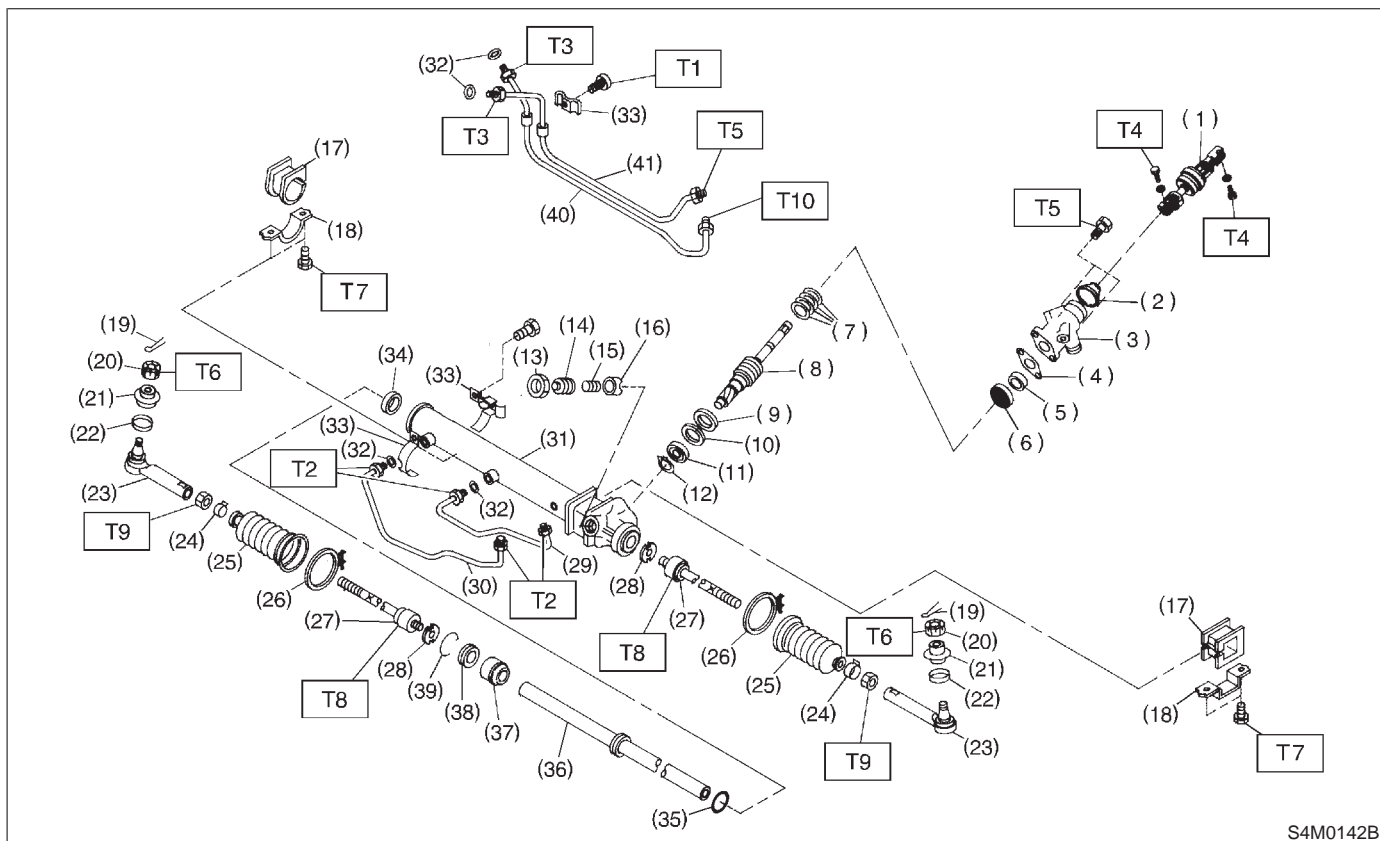

S4M0142B

- |                           |                   |                   |
|---------------------------|-------------------|-------------------|
| (1) Universal joint       | (19) Cotter pin   | (37) Rack bushing |
| (2) Dust cover            | (20) Castle nut   | (38) Rack stopper |
| (3) Valve housing         | (21) Dust cover   | (39) Circlip      |
| (4) Gasket                | (22) Clip         | (40) Pipe E       |
| (5) Oil seal              | (23) Tie-rod end  | (41) Pipe F       |
| (6) Special bearing       | (24) Clip         |                   |
| (7) Seal ring             | (25) Boot         |                   |
| (8) Pinion and valve ASSY | (26) Band         |                   |
| (9) Oil seal              | (27) Tie-rod      |                   |
| (10) Back-up washer       | (28) Lock washer  |                   |
| (11) Ball bearing         | (29) Pipe B       |                   |
| (12) Snap ring            | (30) Pipe A       |                   |
| (13) Lock nut             | (31) Housing ASSY |                   |
| (14) Adjusting screw      | (32) O-ring       |                   |
| (15) Spring               | (33) Clamp        |                   |
| (16) Sleeve               | (34) Oil seal     |                   |
| (17) Adapter              | (35) Piston ring  |                   |
| (18) Clamp                | (36) Rack         |                   |

---

**Tightening torque: N·m (kg·m, ft·lb)**

<b>T1:</b>	<b>6±1 (0.6±0.1, 4.3±0.7)</b>
<b>T2:</b>	<b>13±3 (1.3±0.3, 9.4±2.2)</b>
<b>T3:</b>	<b>15±5 (1.5±0.5, 10.8±3.6)</b>
<b>T4:</b>	<b>24±3 (2.4±0.3, 17.4±2.2)</b>
<b>T5:</b>	<b>25±5 (2.5±0.5, 18.1±3.6)</b>
<b>T6:</b>	<b>27.0±2.5 (2.75±0.25, 19.9±1.8)</b>
<b>T7:</b>	<b>59±12 (6.0±1.2, 43±9)</b>
<b>T8:</b>	<b>78±10 (8.0±1.0, 58±7)</b>
<b>T9:</b>	<b>83±5 (8.5±0.5, 61.5±3.6)</b>
<b>T10:</b>	<b>15±3 (1.5±0.3, 10.8±2.2)</b>

---

## 3. Steering Gearbox (Power Steering System)

- 1) Disconnect battery minus terminal.
- 2) Loosen front wheel nut.
- 3) Lift vehicle and remove front wheels.
- 4) Remove front exhaust pipe assembly.

**WARNING:**

**Be careful, exhaust pipe is hot.**

- 5) Using a puller, remove tie-rod end from knuckle arm after pulling off cotter pin and removing castle nut.

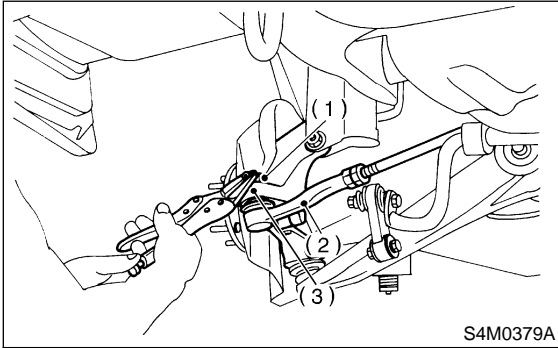

- (1) Castle nut
- (2) Tie-rod end
- (3) Knuckle arm

- 6) Remove jack-up plate and front stabilizer.

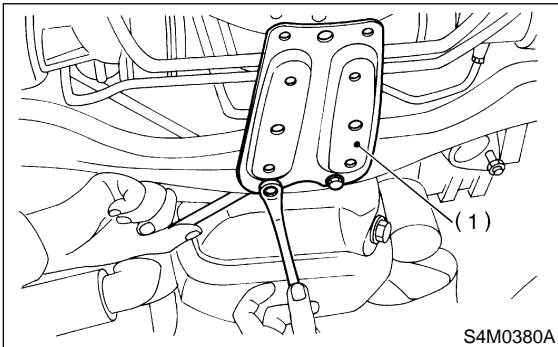

- (1) Jack-up plate

- 7) Remove one pipe joint at the center of gearbox, and connect vinyl hose to pipe and joint. Discharge fluid by turning steering wheel fully clockwise and counterclockwise. Discharge fluid similarly from the other pipe.

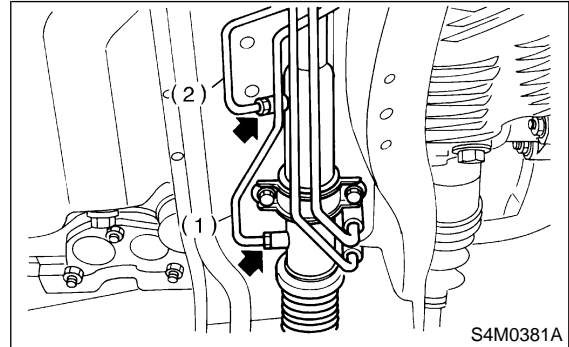

- (1) Pipe A
- (2) Pipe B

- 8) Remove lower side bolt of universal joint, then remove upper side bolt and lift the joint upward.

**NOTE:**

Place a mark on the joint and mating serration so that they can be re-installed at the original position.

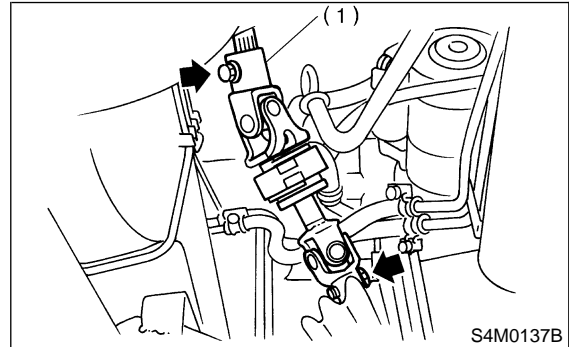

- (1) Universal joint

9) Disconnect pipes C and D from pipe of gear-  
box.

**CAUTION:**

**Be careful not to damage these pipes.**

**NOTE:**

Disconnect upper pipe D first, and lower pipe C  
second.

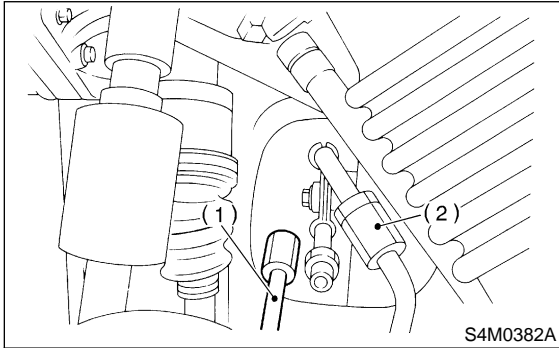

- (1) Pipe C
- (2) Pipe D

10) Remove clamp bolts securing gearbox to  
crossmember, and remove gearbox.

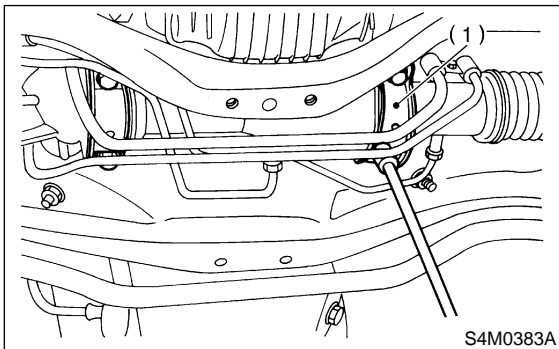

- (1) Clamp

## B: DISASSEMBLY

- 1) Disconnect the four pipes from gearbox.
  - 2) Secure gearbox removed from vehicle in vice  
using ST.
- ST 92620000 STAND

**CAUTION:**

**Secure the gearbox in a vice using the ST as  
shown. Do not attempt to secure it without this  
ST.**

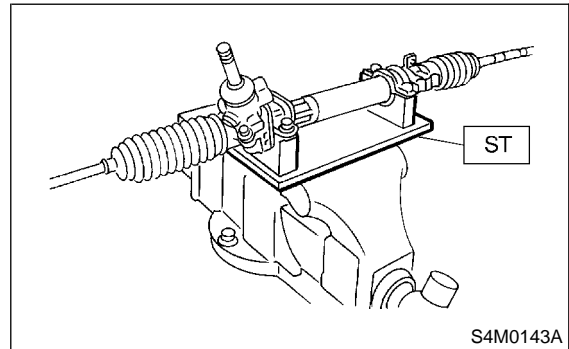

- 3) Remove tie-rod end and lock nut from gearbox.
- 4) Remove small clip from boot using pliers, and  
move boot to tie-rod end side.

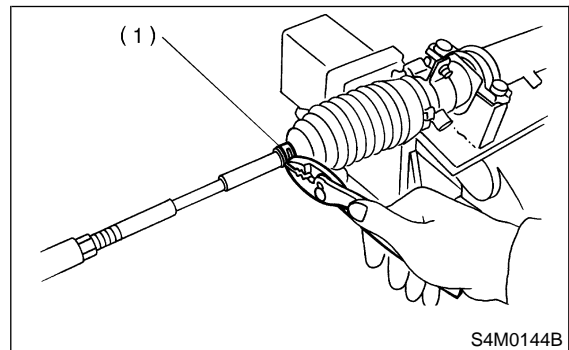

- (1) Clip

5) Using standard screwdriver, remove band from  
boot.

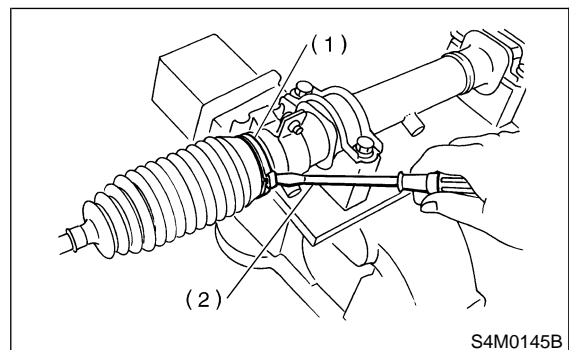

- (1) Band
- (2) Standard screwdriver

3. Steering Gearbox (Power Steering System)

6) Extend rack approximately 40 mm (1.57 in) out. Unlock lock wire at lock washer on each side of tie-rod end using a standard screwdriver.

**CAUTION:**

Be careful not to scratch rack surface as oil leaks may result.

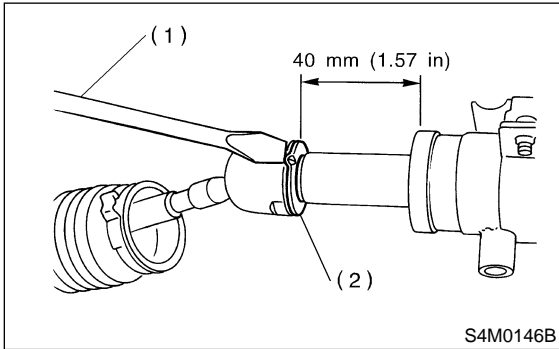

- (1) Standard screwdriver
- (2) Lock washer

7) Using ST, loosen lock nut.  
ST 926230000 SPANNER

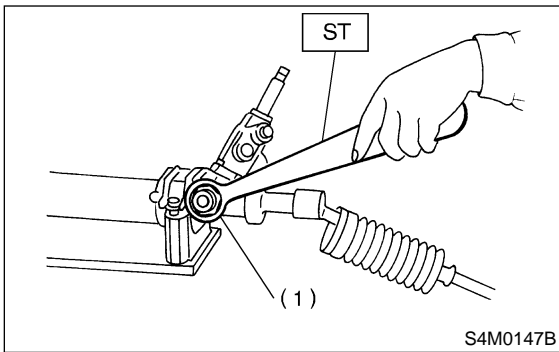

- (1) Lock nut

8) Tighten adjusting screw until it no longer tightens.

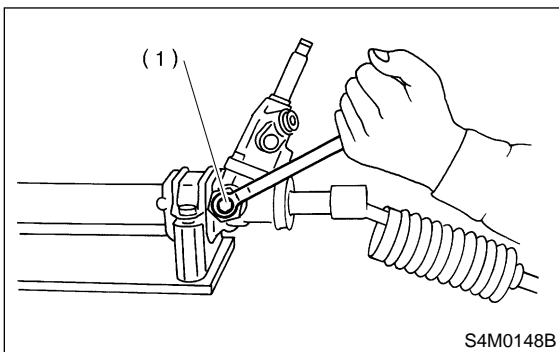

- (1) Adjusting screw

9) Using a wrench [32 mm (1.26 in) width across flats] or adjustable wrench, remove tie-rod.

**CAUTION:**

- Check ball joint for free play, and tie-rod for bends. Replace if necessary.
- Check dust seals used with tie-rod end ball joint for damage or deterioration. Replace if necessary.

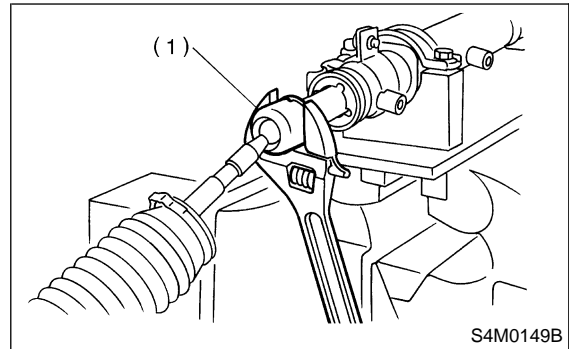

- (1) Tie-rod

10) Loosen adjusting screw and remove spring and sleeve.

**CAUTION:**

Replace spring and/or sleeve if damaged.

**C: INSPECTION**

- 1) Clean all disassembled parts, and check for wear, damage, or any other faults, then repair or replace as necessary.
- 2) When disassembling, check inside of gearbox for water. If any water is found, carefully check boot for damage, input shaft dust seal, adjusting screw and boot clips for poor sealing. If faulty, replace with new parts.

No.	Parts	Inspection	Corrective action
1	Input shaft	(1) Bend of input shaft (2) Damage on serration	If bend or damage is excessive, replace entire gearbox.
2	Dust seal	(1) Crack or damage (2) Wear	If outer wall slips, lip is worn out or damage is found, replace it with new one.
3	Rack and pinion	Poor mating of rack with pinion	(1) Adjust backlash properly. By measuring turning torque of gearbox and sliding resistance of rack, check if rack and pinion engage uniformly and smoothly with each other. (Refer to "Service limit".) (2) Keeping rack pulled out all the way so that all teeth emerge, check teeth for damage. Even if abnormality is found in either (1) or (2), replace entire gearbox.
4	Gearbox unit	(1) Bend of rack shaft (2) Bend of cylinder portion (3) Crack or damage on cast iron portion	Replace gearbox with new one.
		(4) Wear or damage on rack bush	If free play of rack shaft in radial direction is out of the specified range, replace gearbox with new one. (Refer to "Service limit".)
		(5) Wear on input shaft bearing	If free plays of input shaft in radial and axial directions are out of the specified ranges, replace gearbox with new one. (Refer to "Service limit".)
5	Boot	Crack, damage or deterioration	Replace.
6	Tie-rod	(1) Looseness of ball joint (2) Bend of tie-rod	Replace.
7	Tie-rod end	Damage or deterioration on dust seal	Replace.
8	Adjusting screw spring	Deterioration	Replace.
9	Boot clip	Deterioration	Replace.
10	Sleeve	Damage	Replace.
11	Pipes	(1) Damage to flared surface (2) Damage to flare nut (3) Damage to pipe	Replace.

**1. SERVICE LIMIT**

Make a measurement as follows. If it exceeds the specified service limit, adjust or replace.

**NOTE:**

When making a measurement, vise gearbox by using ST. Never vise gearbox by inserting aluminum plates, etc. between vise and gearbox.

ST 926200000 STAND

**Sliding resistance of rack shaft:**

**Service limit**

**304.0 N (31.0 kg, 68.4 lb) or less**

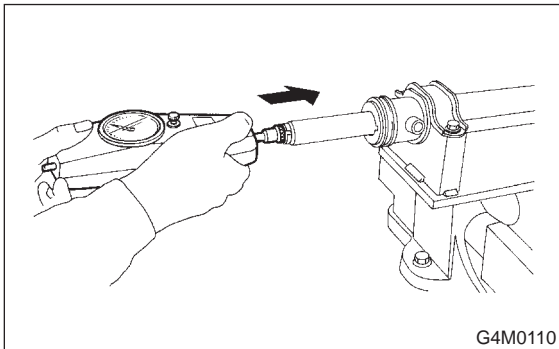
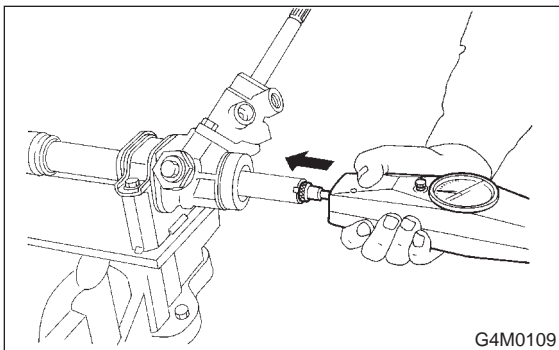

**2. RACK SHAFT PLAY IN RADIAL DIRECTION**

**Right-turn steering:**

**Service limit**

**0.15 mm (0.0059 in) or less**

**On condition**

**L: 5 mm (0.20 in)**

**P: 98 N (10 kg, 22 lb)**

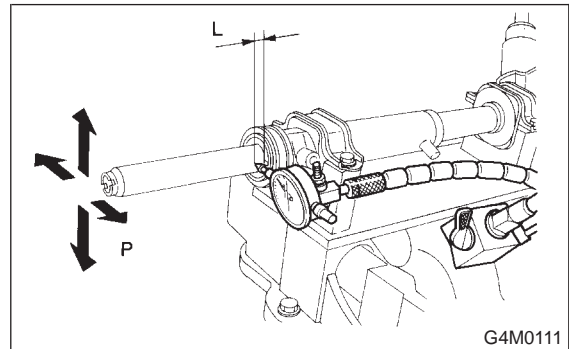

**Left-turn steering:**

**Service limit**

**Direction** ← →

**0.3 mm (0.012 in) or less**

**Direction** ← →

**0.15 mm (0.0059 in) or less**

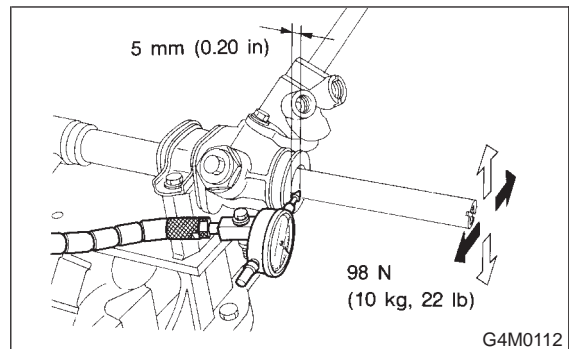

**3. INPUT SHAFT PLAY**

*In radial direction:*

**Service limit**

**0.18 mm (0.0071 in) or less**

**On condition**

**P: 98 N (10 kg, 22 lb)**

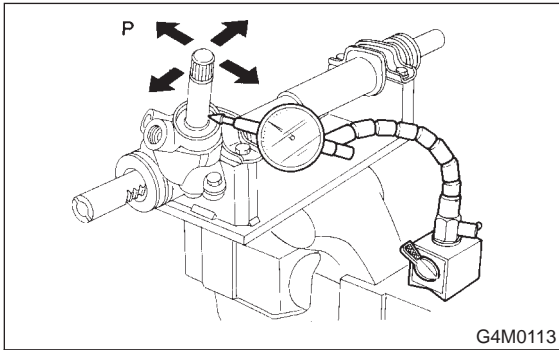

*In axial direction:*

**Service limit**

**0.1 mm (0.004 in) or less**

**On condition**

**P: 20 — 49 N (2 — 5 kg, 4 — 11 lb)**

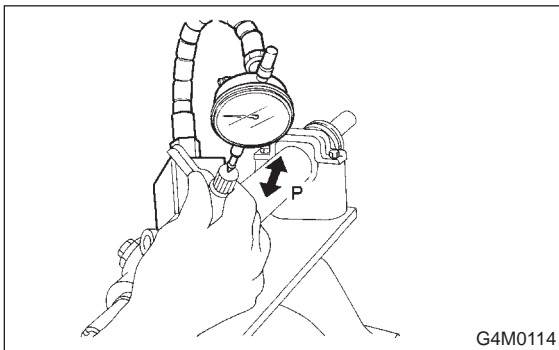

**4. TURNING RESISTANCE OF GEARBOX**

Using ST, measure gearbox turning resistance.

ST 926230000 SPANNER

**Service limit:**

**Straight-ahead position within 30 mm (1.18 in) from rack center**

**Less than 11.18 N (1.14 kg, 2.51 lb)**

**Maximum allowable resistance**

**12.7 N (1.3 kg, 2.9 lb)**

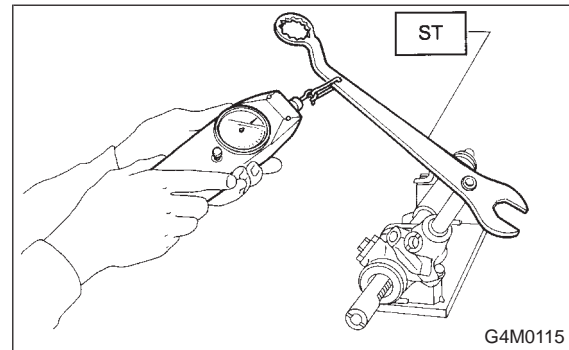

**D: ASSEMBLY****CAUTION:**

Use only SUBARU genuine grease for gearbox.

**Grease:**

**VALIANT GREASE M2**

[Part No. 003608001, net 0.5 kg (1.1 lb)]

- 1) Clean all parts and tools before reassembling.
- 2) Apply grease to teeth of rack so that grease applied is about as high as teeth, and also apply a thin film of grease to sliding portion of rack shaft.

**CAUTION:**

- When moving rack to stroke end without tie-rod attached, prevent shocks from being applied at the end.
- Do not apply grease to threaded portion at end of rack shaft.
- Move rack shaft to stroke end two or three times to squeeze grease which accumulates on both ends. Remove grease to prevent it from choking air passage hole.

- 3) Apply grease to sleeve insertion hole.
- 4) Apply grease to dust seal insertion hole.

**CAUTION:**

Apply clean grease with clean hands. If material having a sharp edge is used for applying grease, oil seal at the inside might be damaged.

- 5) Apply grease to sliding surface of sleeve and spring seat, then insert sleeve into pinion housing. Fit spring into sleeve screw, pack grease inside of screw, then install the screw.

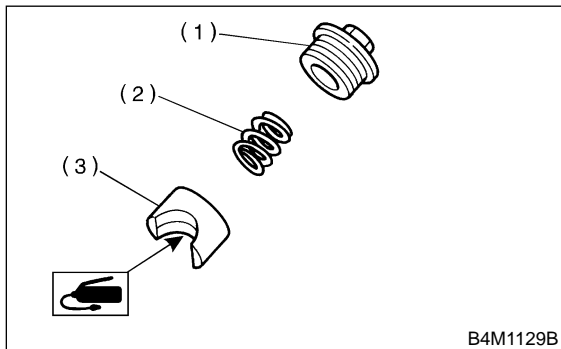

- (1) Adjusting screw
- (2) Spring
- (3) Sleeve

- 6) Install lock washers and tighten left and right tie-rods into rack ends.

**On condition**

**L: Approximately 40 mm (1.57 in)**

**Tightening torque:**

**78±10 N·m (8.0±1.0 kg·m, 58±7 ft·lb)**

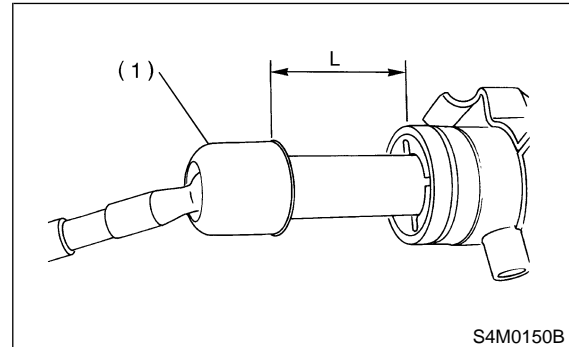

- (1) Tie-rod

- 7) Bend lock washer using a chisel.

**CAUTION:**

**Be careful not to scratch rack when bending lock washer.**

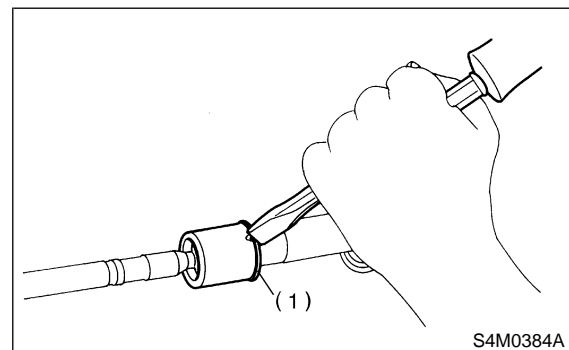

- (1) Lock washer



- 8) Rack and pinion backlash adjustment
- (1) Loosen adjusting screw.
  - (2) Rotate input shaft so that rack is in the straight ahead direction.
  - (3) Apply grease to sleeve.

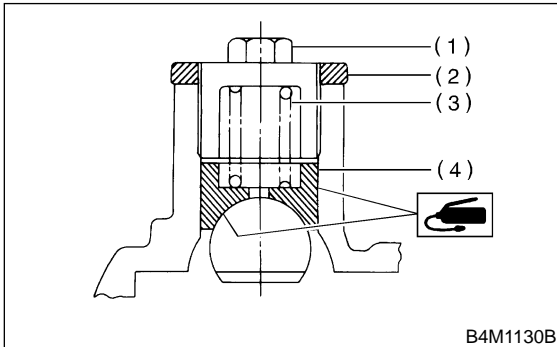

- (1) Adjusting screw
- (2) Lock nut
- (3) Spring
- (4) Sleeve

- (4) Tighten adjusting screw by the two threads.

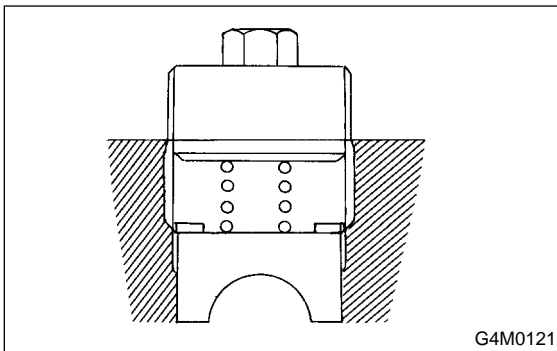

- (5) Apply liquid packing to at least 1/3 of entire perimeter of adjusting screw thread.

**Liquid packing:**  
**THREE BOND 1141**

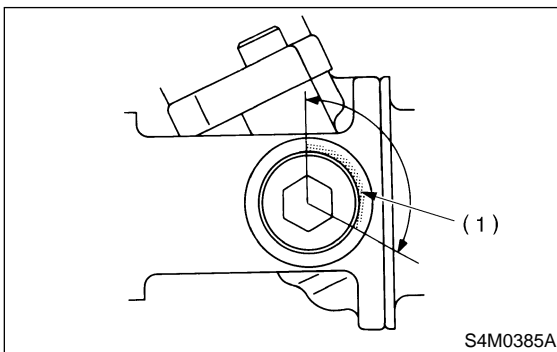

- (1) Apply liquid packing to at least 1/3 of entire perimeter.

- (6) Tighten adjusting screw to 7.4 N-m (0.75 kg-m, 5.4 ft-lb) and back off 25°.

- (7) Install lock nut. While holding adjusting screw with a wrench, tighten lock nut using ST. ST 926230000 SPANNER

**Tightening torque (Lock nut):**  
**39±10 N-m (4.0±1.0 kg-m, 29±7 ft-lb)**

**NOTE:**

- Hold adjusting screw with a wrench to prevent it from turning while tightening lock nut.
- Make adjustment so that steering wheel can be rotated fully from lock to lock without binding.

- 9) Check for service limit as per article of "Service limit". <Ref. to 4-3 [W3C1].> Make replacement and adjustment if necessary.

- 10) Install boot to housing.

**NOTE:**

- Before installing boot, be sure to apply grease to the groove of tie-rod.
- Install fitting portions of boots to the following portions in both sides of assembled steering gearbox.

The groove on gearbox

The groove on the rod

- Make sure that boot is installed without unusual inflation or deflation.

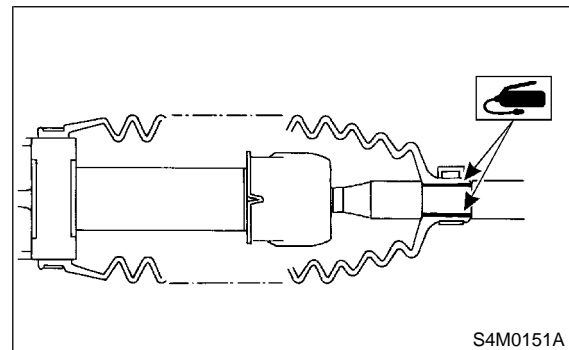

## 3. Steering Gearbox (Power Steering System)

11) Using a screwdriver, tighten the screw until the ends "A" and "B" of the band come into contact with each other.

**CAUTION:**

**Use a new band.**

**NOTE:**

Always tighten the band from the underside of the gearbox.

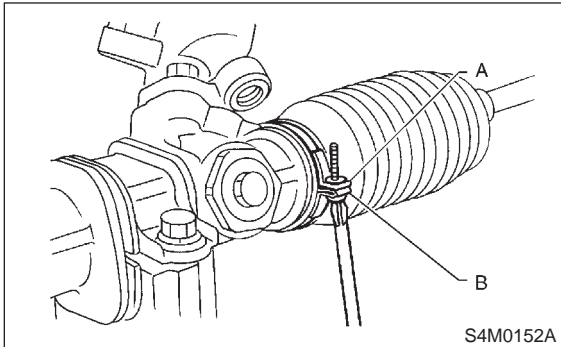

12) Fix boot end with clip (small).

**CAUTION:**

**After installing, check boot end is positioned into groove on tie-rod.**

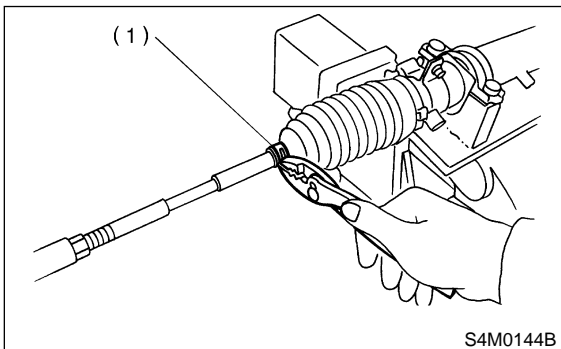

(1) Clip

13) If tie-rod end was removed, screw in lock nut and tie-rod end to screwed portion of tie-rod, and tighten lock nut temporarily in a position as shown in figure.

**Installed tie-rod length: L**

**15 mm (0.59 in)**

**NOTE:**

Pay attention to difference between right and left tie-rod ends.

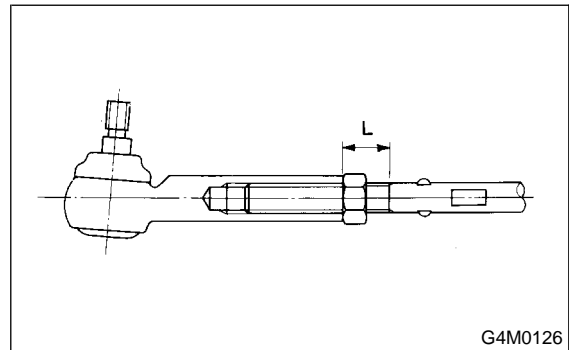

14) Inspect gearbox as follows:

"A" Holding tie-rod end, repeat lock to lock two or three times as quickly as possible.

"B" Holding tie-rod end, turn it slowly at a radius one or two times as large as possible.

After all, make sure that boot is installed in the specified position without deflation.

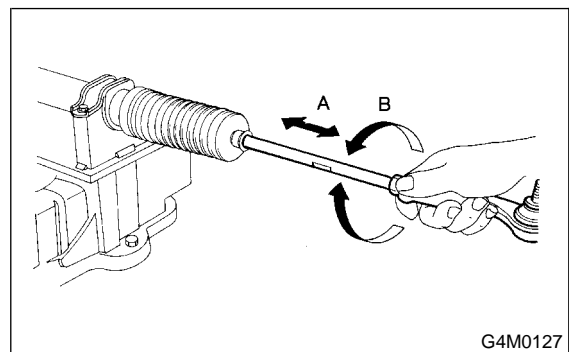

15) Remove gearbox from ST.

ST 926200000 STAND

16) Install the four pipes on gearbox.

(1) Connect pipes A and B to the four pipe joints of gearbox. Connect upper pipe B first, and lower pipe A.

**Tightening torque:**

**13±3 N·m (1.3±0.3 kg·m, 9.4±2.2 ft·lb)**

- (2) Connect pipes C and D to gearbox.  
Connect lower pipe C first, and upper pipe D second.

**Tightening torque:**

**15±5 N·m (1.5±0.5 kg·m, 10.8±3.6 ft·lb)**

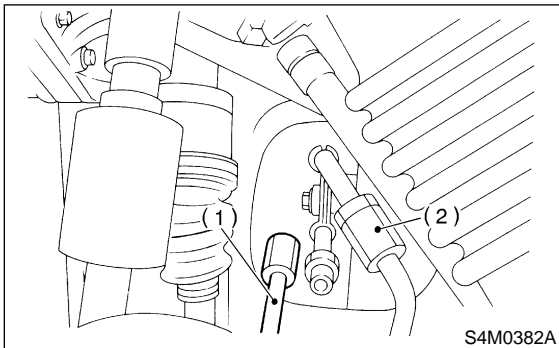

- (1) Pipe C
- (2) Pipe D

**E: INSTALLATION**

- 1) Insert gearbox into crossmember, being careful not to damage gearbox boot.
- 2) Tighten gearbox to crossmember bracket via clamp with bolt to the specified torque.

**Tightening torque:**

**59±12 N·m (6.0±1.2 kg·m, 43±9 ft·lb)**

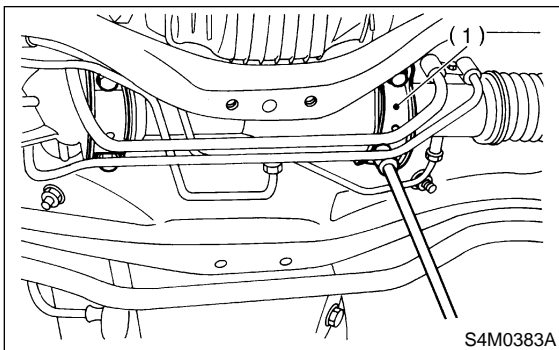

- (1) Clamp

**3) How to install the joint.**

- (1) Push the long yoke of the joint, all the way into the serrated portion of the steering shaft, setting the bolt hole in the cutout.
- (2) Then pull the short yoke all way out of the serrated portion of the gearbox, setting the bolt hole in the cutout.
- (3) Insert the bolt through the short yoke, pull the joint and confirm that the bolt is on cutout of the gearbox.

- (4) Fasten the short yoke side with a spring washer and bolt, then fasten the long yoke side.

**Tightening torque:**

**24±3 N·m (2.4±0.3 kg·m, 17.4±2.2 ft·lb)**

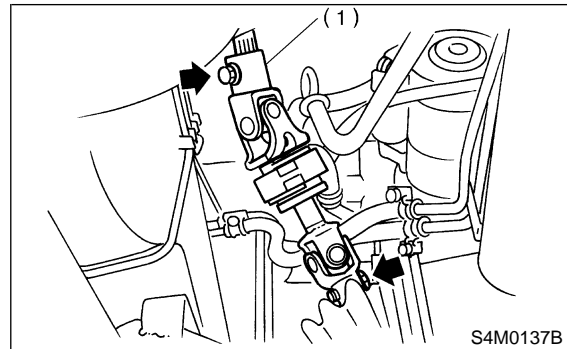

- (1) Universal joint

- 4) Connect tie-rod end and knuckle arm, and tighten with castle nut. Fit cotter pin into the nut and bend the pin to lock.

**Castle nut tightening torque:**

**Tighten to 27.0±2.5 N·m (2.75±0.25 kg·m, 19.9±1.8 ft·lb), and tighten further within 60° until cotter pin hole is aligned with a slot in the nut.**

**CAUTION:**

**When connecting, do not hit cap at the bottom of tie-rod end with hammer.**

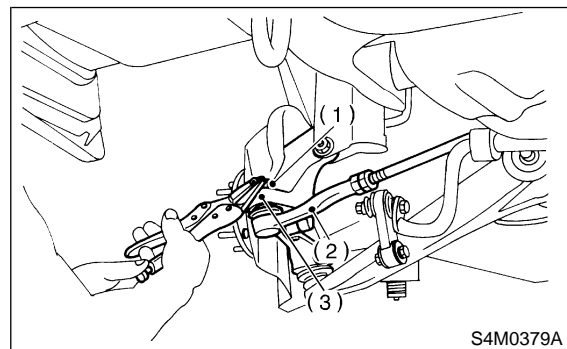

- (1) Castle nut
- (2) Tie-rod end
- (3) Knuckle arm

- 5) Install front stabilizer to vehicle.
- 6) Install front exhaust pipe assembly.  
<Ref. to 2-9 [W1B0].>
- 7) Install tires.
- 8) Tighten wheel nuts to the specified torque.

**Tightening torque:**

**88±10 N·m (9.0±1.0 kg·m, 65±7 ft·lb)**

- 9) Connect ground cable to battery.
- 10) Pour fluid into oil tank, and bleed air.  
<Ref. to 4-3 [W7A0].>
- 11) Check for fluid leaks.

## 3. Steering Gearbox (Power Steering System)

12) Install jack-up plate.

**WARNING:**

**Be careful, exhaust manifold is hot.**

13) Lower vehicle.

14) Check fluid level in oil tank.

15) After adjusting toe-in and steering angle, tighten lock nut on tie-rod end.

**Tightening torque:**

**$83 \pm 5 \text{ N}\cdot\text{m}$  ( $8.5 \pm 0.5 \text{ kg}\cdot\text{m}$ ,  $61.5 \pm 3.6 \text{ ft}\cdot\text{lb}$ )**

**CAUTION:**

When adjusting toe-in, hold boot as shown to prevent it from being rotated or twisted. If twisted, straighten it.

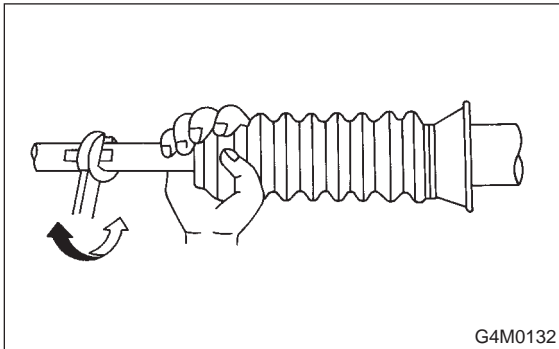
**F: ADJUSTMENT**

1) Adjust front toe.

**Standard of front toe:**

**IN 3 — OUT 3 mm (IN 0.12 — OUT 0.12 in)**

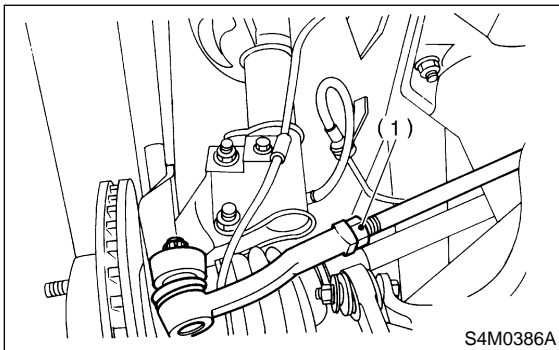

(1) Lock nut

2) Adjust steering angle of wheels.

**Inner wheel:  $34.4 \pm 1.5^\circ$**

**Outer wheel:  $30.2 \pm 1.5^\circ$**

3) If steering wheel spokes are not horizontal when wheels are set in the straight ahead position, and error is more than  $5^\circ$  on the periphery of steering wheel, correctly re-install the steering wheel.

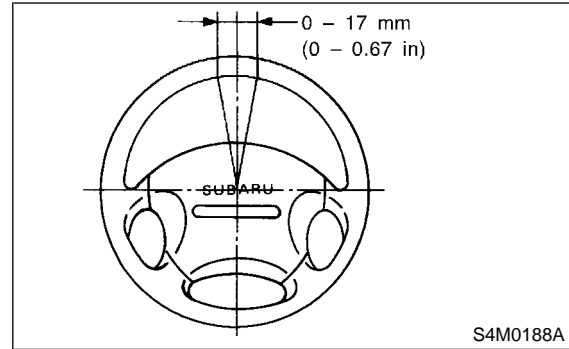

4) If steering wheel spokes are not horizontal with vehicle set in the straight ahead position after this adjustment, correct it by turning the right and left tie-rods in the same direction by the same turns.

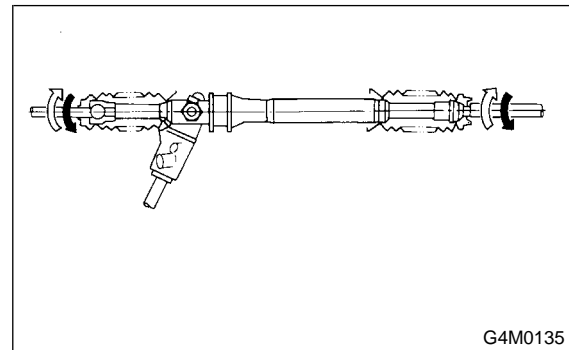

## 4. Control Valve (Power Steering Gearbox)

### A: CHECKING OIL LEAKING POINTS

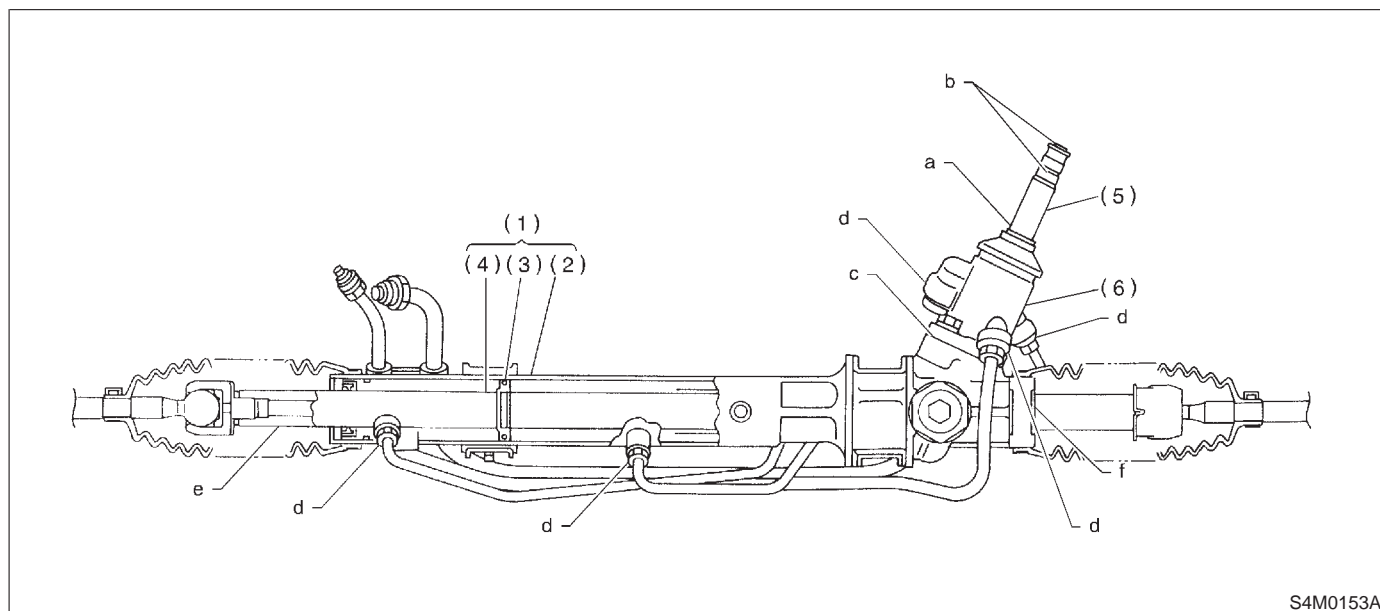

S4M0153A

(1) Power cylinder  
(2) Cylinder

(3) Rack piston  
(4) Rack axle

(5) Input shaft  
(6) Valve housing

#### 1. OIL LEAKING POINTS

1) If leak point is other than a, b, c, or d, perform the 5th step in "OIL LEAK CHECK PROCEDURE AND REPLACEMENT PARTS" before dismounting gearbox from vehicle. <Ref. to 4-3 [W4A2].> If gearbox is dismounted without confirming where the leak is, it must be mounted again to locate the leak point.

2) Even if the location of the leak can be easily found by observing the leaking condition, it is necessary to thoroughly remove the oil from the suspected portion and turn the steering wheel from lock to lock about 30 to 40 times with engine running, then make comparison of the suspected portion between immediately after and several hours after this operation.

3) Before starting oil leak repair work, be sure to clean the gearbox, hoses, pipes, and surrounding parts. After completing repair work, clean these areas again.

#### 2. OIL LEAK CHECK PROCEDURE AND REPLACEMENT PARTS

##### NOTE:

Parts requiring replacement are described in the smallest unit of spare parts including damaged parts and spare parts damaged. In actual disassembly work, accidental damage as well as inevitable damage to some related parts must be taken into account, and spare parts for them must also be prepared. However, it is essential to pinpoint the cause of trouble, and limit the number of replacement parts as much as possible.

##### 1) Leakage from "a"

The oil seal is damaged. Replace valve assembly with a new one.

##### 2) Leakage from "b"

The torsion bar O-ring is damaged. Replace valve assembly with a new one.

##### 3) Leakage from "c"

The oil seal is damaged. Replace valve assembly or oil seal with a new one.

##### 4) Leakage from "d"

The pipe is damaged. Replace the faulty pipe or O-ring.

5) If leak is other than a, b, c, or d, and if oil is leaking from the gearbox, move the right and left boots toward tie-rod end side, respectively, with the gearbox mounted to the vehicle, and remove oil from the surrounding portions. Then, turn the steering wheel from lock to lock 30 to 40 times with the

4. Control Valve (Power Steering Gearbox)

engine running, then make comparison of the leaked portion immediately after and several hours after this operation.

(1) Leakage from "e"

The cylinder seal is damaged. Replace rack bush with a new one.

(2) Leakage from "f"

There are two possible causes. Take the following step first. Remove the pipe assembly B from the valve housing, and close the circuit with ST.

ST 926420000 PLUG

Turn the steering wheel from lock to lock 30 to 40 times with the engine running, then make comparison of the leaked portion between immediately after and several hours after this operation.

**CAUTION:**

● If leakage from "f" is noted again:

The oil seal of pinion and valve assembly is damaged. Replace pinion and valve assembly with a new one. Or replace the oil seal and the parts that are damaged during disassembly with new ones.

● If oil stops leaking from "f":

The oil seal of rack housing is damaged. Replace the oil seal and the parts that are damaged during disassembly with new ones.

**B: DISASSEMBLY**

**NOTE:**

This section focuses on the disassembly and reassembly of control valve. For the inspection and adjustment and the service procedures for associated parts, refer to "Steering Gearbox". <Ref. to 4-3 [W3A0].>

**1. VALVE ASSEMBLY**

1) Remove the two bolts securing valve assembly.

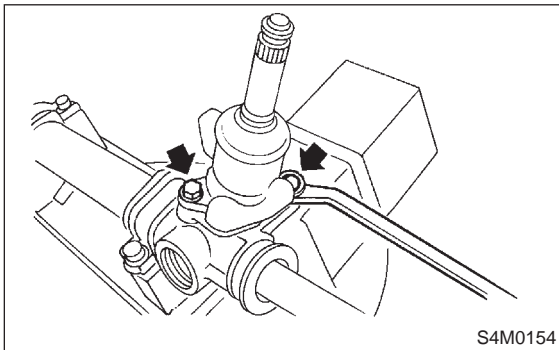

2) Carefully draw out input shaft and remove valve assembly.

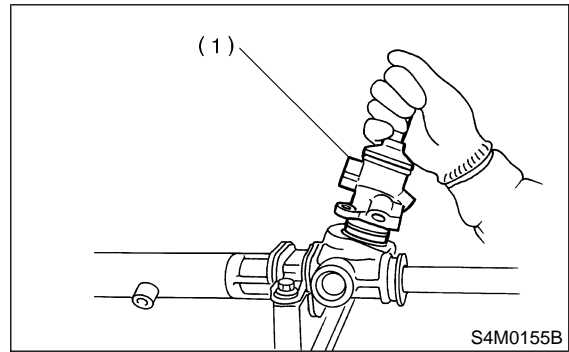

(1) Valve ASSY

3) Slide dust cover out.

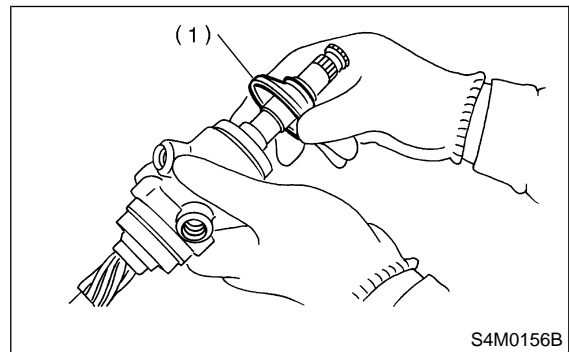

(1) Dust cover

4) Using a press remove pinion and valve assembly from valve housing.

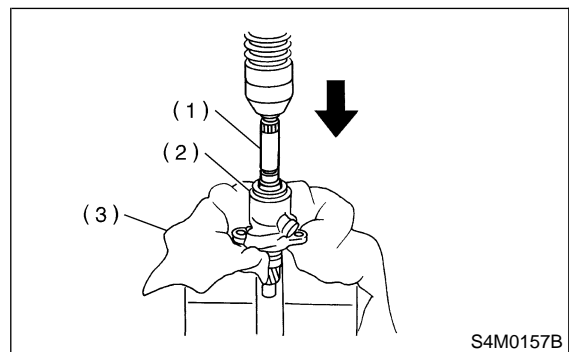

(1) Valve ASSY  
(2) Valve housing  
(3) Cloth

**2. RACK ASSEMBLY**

1) Using a sharp pointed pliers, rotate the rack stopper in the direction of the arrow until the end of the circlip comes out of the stopper. Rotate the circlip in the opposite direction and pull it out.

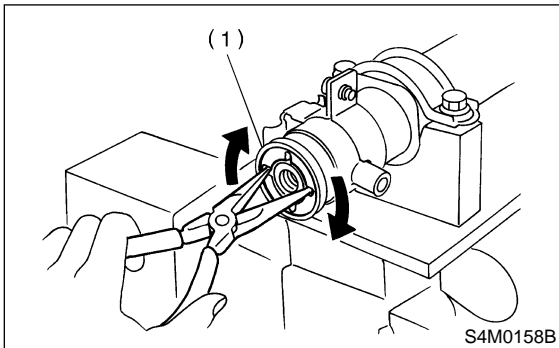

(1) Rack stopper

2) Pull rack assembly from cylinder side, and draw out rack bushing and rack stopper together with rack assembly.

**CAUTION:**

**Be careful not to contact rack to inner wall of cylinder when drawing out. Any scratch on cylinder inner wall will cause oil leakage.**

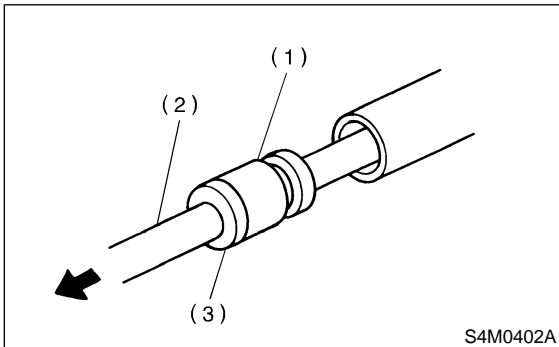

(1) Rack bushing  
(2) Rack ASSY  
(3) Rack stopper

3) Remove rack bushing and rack stopper from rack assembly.

**CAUTION:**

**Do not reuse removed rack bushing and circlip.**

**C: REPLACEMENT OF SEAL AND PACKING**

**1. VALVE HOUSING OIL SEAL**

*Specified steering grease:*

**VALIANT GREASE M2 (Part No. 003608001)**

1) Using ST and a press, remove dust seal, oil seal and special bearing from valve housing.

ST 34099FA120 SEAL INSTALLER & REMOVER

**CAUTION:**

- Do not apply a force to end surface of valve housing.
- Do not reuse oil seal after removal.

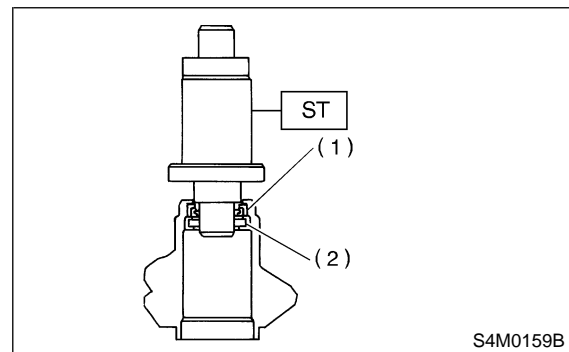

(1) Oil seal  
(2) Special bearing

2) Apply a coat of specified power steering fluid to inner wall of valve housing.

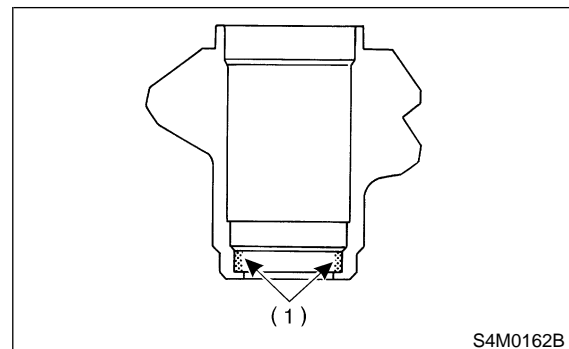

(1) Fluid

4. Control Valve (Power Steering Gearbox)

3) Attach ST2 to ST1, and press oil seal into place using a press.

ST1 34099FA120 SEAL INSTALLER & REMOVER

ST2 34099FA130 SEAL INSTALLER

(1) Face oil seal in the direction shown in figure when installing.

(2) To avoid scratching oil seal, apply a coat of grease to contact surface of installer and oil seal.

(3) To facilitate installation, attach oil seal to installer and position in valve housing before pressing into place.

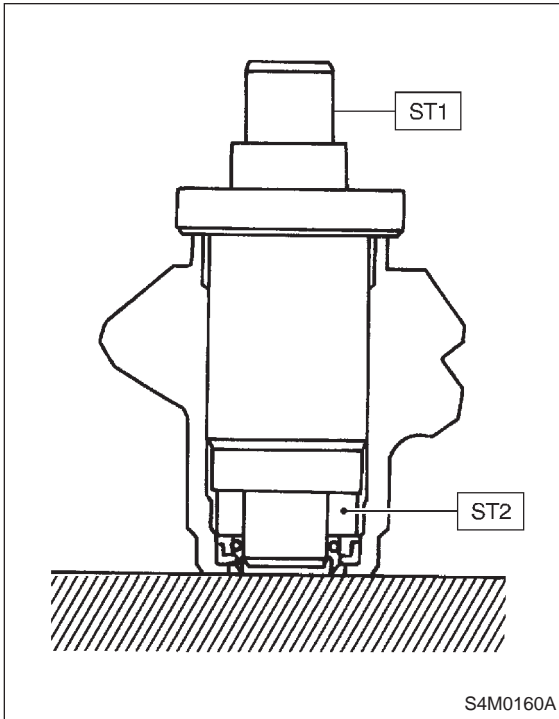

4) Using ST and press, install special bearing in valve housing.

ST 34099FA120 SEAL INSTALLER & REMOVER

**NOTE:**

To facilitate installation, attach ball bearing to remover and position in valve housing before pressing it into place.

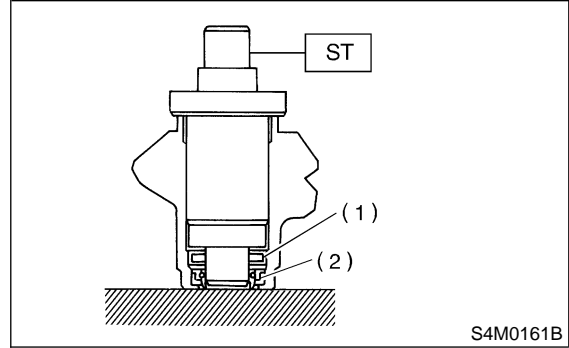

- (1) Special bearing
- (2) Oil seal

**2. PINION AND VALVE ASSEMBLY**

1) Remove snap ring using snap ring pliers.

**CAUTION:**

- Do not reuse removed snap ring.
- Be careful not to scratch pinion and valve assembly.

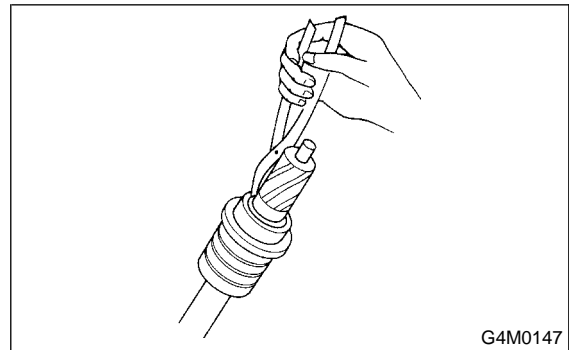



2) Press out bearing together with backing washer using pipe of I.D. 38.5 to 39.5 mm (1.516 to 1.555 in) and press.

**CAUTION:**

**Do not reuse removed bearing.**

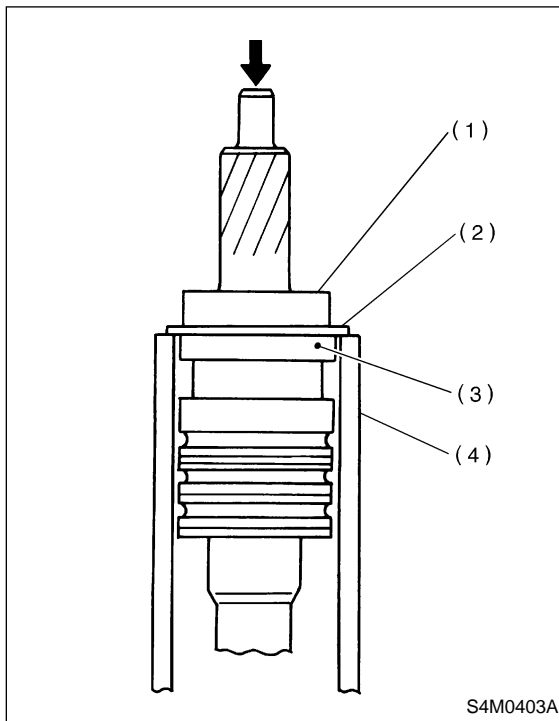

- (1) Bearing
- (2) Backing washer
- (3) Oil seal
- (4) Pipe

3) Remove oil seal.

**CAUTION:**

**Do not reuse removed oil seal.**

4) Put vinyl tape around pinion shaft splines to protect oil seal from damage.

5) Fit pinion and valve assembly into valve housing.

**NOTE:**

Apply specified power steering fluid to outer diameter surface of input shaft and outer surface of valve body seal ring, and pay special attention not to damage seal when inserting pinion and valve assembly.

6) Secure valve assembly to ST1 and ST2.

7) Put ST3 over pinion, and insert oil seal, then force-fit oil seal into housing using ST4.

ST1 926370000 INSTALLER A

ST2 34099FA100 STAND BASE

ST3 926360000 INSTALLER A

ST4 927620000 INSTALLER B

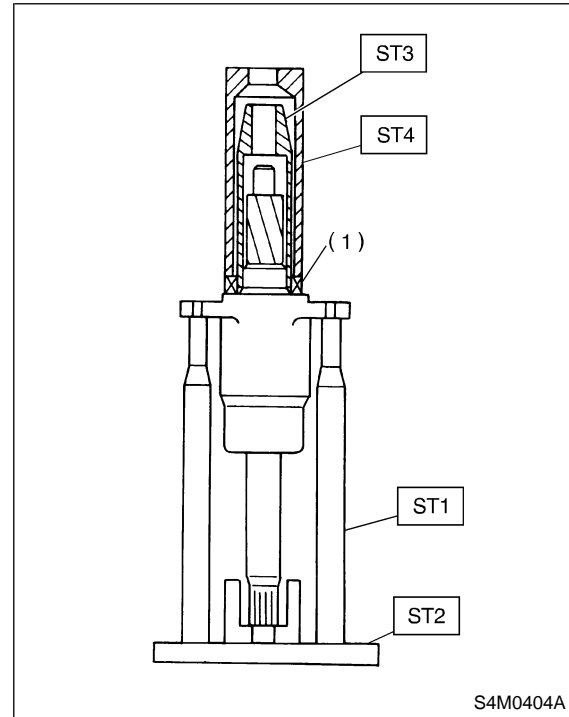

- (1) Oil seal

**NOTE:**

- Apply specified power steering fluid to oil seal and ST3, being careful not to damage oil seal lip.
- Push oil seal until ST3 contacts housing end face.

8) Remove ST3, and fit backing washer.

4. Control Valve (Power Steering Gearbox)

- 9) Force-fit ball bearing using ST3.
- ST1 926370000 INSTALLER A
- ST2 34099FA100 STAND BASE
- ST3 927640000 INSTALLER B

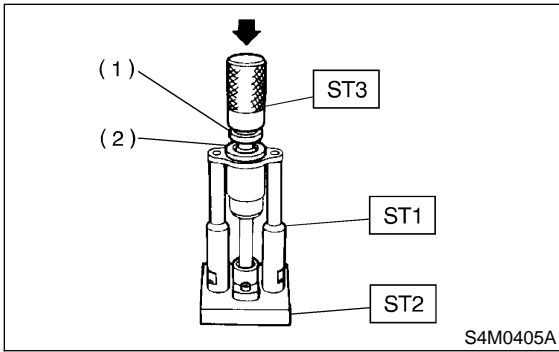

- (1) Ball bearing
- (2) Backing washer

**NOTE:**  
Be careful not to tilt ball bearing during installation.

- 10) Install snap ring using snap ring pliers.

**NOTE:**  
Rotate snap ring to check for proper installation.

**3. RACK HOUSING OIL SEAL**

- 1) Insert ST from pinion housing side and remove oil seal using a press.
- ST 34199AE050 OIL SEAL REMOVER

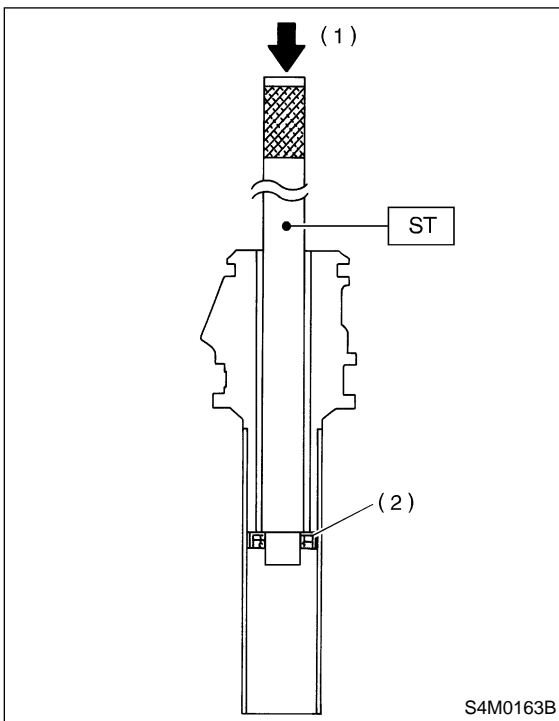

- (1) Press
- (2) Oil seal

**NOTE:**  
Discard removed oil seal.

- 2) Force-fit oil seal using ST.
- ST 34099FA110 INSTALLER

**CAUTION:**  
Be careful not to damage or scratch cylinder inner wall.

**NOTE:**

- Apply specified power steering fluid to oil seal.
- Pay special attention not to install oil seal in wrong direction.
- Push oil seal until the stepped portion of A contacts end face of B.

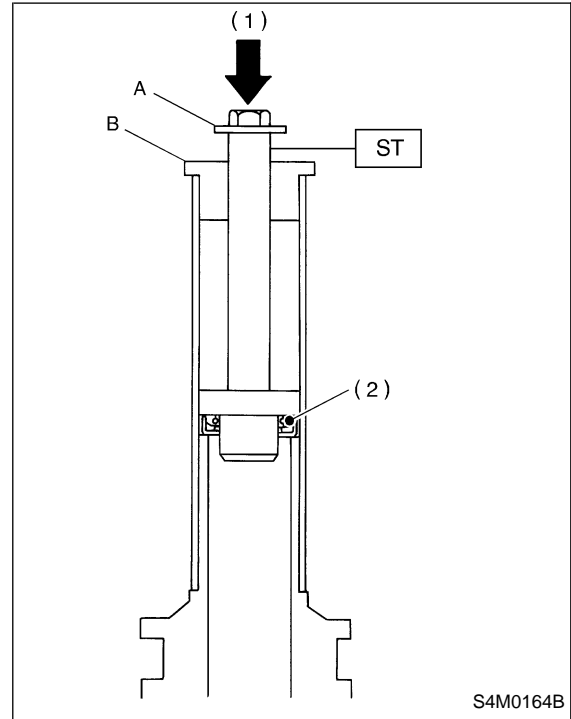

- (1) Press
- (2) Oil seal

**D: ASSEMBLY**

**1. RACK ASSEMBLY**

**CAUTION:**

Use only SUBARU genuine grease for gearbox.

**Specified grease for gearbox:**  
**VALIANT GREASE M2 (Part No. 003608001)**

- 1) Fixing rack housing  
 Fix rack housing in vice using ST.  
 ST 926200000 STAND

**CAUTION:**

- When fixing rack housing in vice, be sure to use this special tool. Do not fix rack housing in vice using pad such as aluminum plates, etc.
- When using old rack housing, be sure to clean and remove rust before assembling. Check pinion housing bushing carefully.

- 2) Fit ST over toothed portion of rack assembly, and check for binding or unsmooth insertion. If any deformation is noted on flats at the end of rack, shape by using file, and wash with cleaning fluid.  
 ST 926390001 COVER and REMOVER

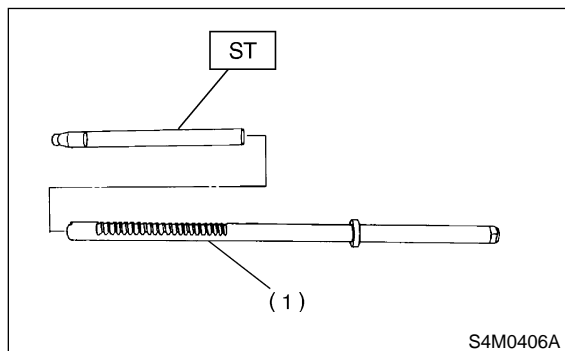

(1) Rack ASSY

- 3) Apply genuine grease to teeth of thoroughly washed rack assembly, and fit ST over the toothed portion.

**CAUTION:**

- Be careful not to block air passage with grease. Remove excessive grease.
- After fitting cover, check air passage hole for clogging. If clogged, open by removing grease from the hole.
- Check rack shaft for damage.
- Apply specified power steering fluid to this ST and surface of piston ring to prevent seal from being damaged.

- 4) Insert rack assembly into rack housing from cylinder side, and remove ST after it has passed completely through oil seal.

**NOTE:**

Before inserting rack assembly, apply a coat of specified power steering fluid to surfaces of ST and rack piston.

ST 926390001 COVER AND REMOVER

- 5) Fit ST1 and ST2 over the end of rack, and install rack bushing.

ST1 926400000 GUIDE  
 ST2 927660000 GUIDE

**CAUTION:**

- If burrs, or nicks are found on this guide and rack shaft portion, remove by filing.
- Dip rack bushing in specified power steering fluid before installing, and pay attention not to damage O-ring and oil seal.

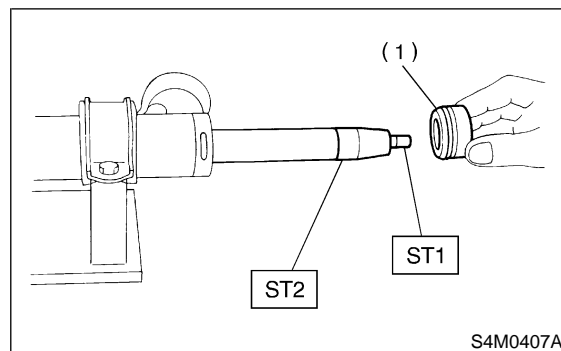

(1) Rack bushing ASSY

## 4. Control Valve (Power Steering Gearbox)

6) Insert rack stopper into cylinder tube until internal groove (on cylinder side) is aligned with external groove (on rack stopper). Turn rack stopper with ST so that rack stopper hole is seen through cylinder slits.

7) Insert rack stopper into rack housing, and wrap circlip using a sharp pointed pliers to secure rack stopper in position.

**CAUTION:**

**Be careful not to scratch rack while winding circlip.**

**NOTE:**

Rotate wrench another 90 to 180° after the end of circlip has been wrapped in.

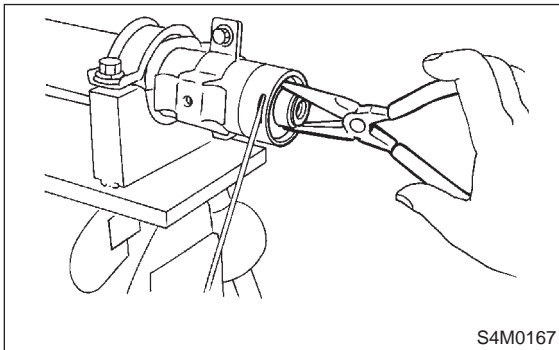

8) Fit mounting rubber onto rack housing.

**2. VALVE ASSEMBLY****CAUTION:**

**Use only SUBARU genuine grease for gearbox.**

**Specified grease for gearbox:**

**VALIANT GREASE M2 (Part No. 003608001)**

1) Apply specified grease to dust cover.

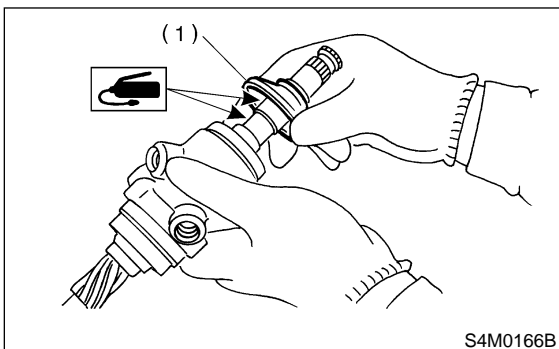

(1) Dust cover

2) Install dust cover on valve assembly.

3) Apply genuine grease to pinion gear and bearing of valve assembly.

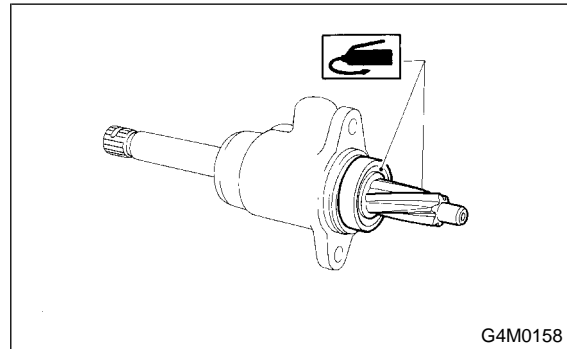

4) Install gasket on valve assembly. Insert valve assembly into place while facing rack teeth toward pinion.

**CAUTION:**

**Be sure to use a new gasket.**

**NOTE:**

Do not allow packing to be caught when installing valve assembly.

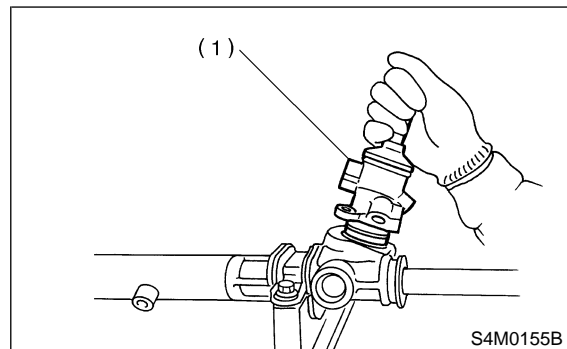

(1) Valve ASSY

5) Tighten bolts alternately to secure valve assembly.

**Tightening torque:**

**25±5 N·m (2.5±0.5 kg·m, 18.1±3.6 ft·lb)**

**CAUTION:**

**Be sure to alternately tighten bolts.**

## 5. Pipe Assembly (Power Steering System)

### A: REMOVAL

- 1) Disconnect battery minus terminal.
- 2) Lift vehicle and remove jack-up plate.

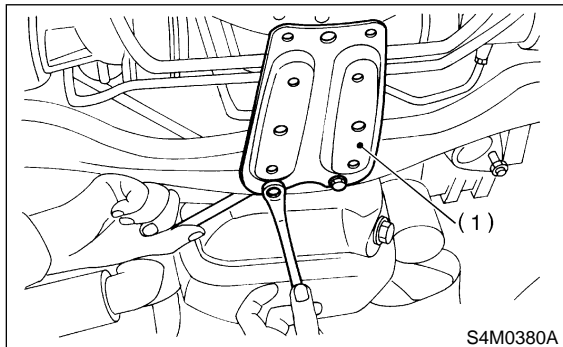

(1) Jack-up plate

3) Remove one pipe joint at the center of gearbox, and connect vinyl hose to pipe and joint. Discharge fluid by turning steering wheel fully clockwise and counterclockwise. Discharge fluid similarly from the other pipe.

**CAUTION:**

**Improper removal and installation of parts often causes fluid leak trouble. To prevent this, clean the surrounding portions before disassembly and reassembly, and pay special attention to keep dirt and other foreign matter from mating surfaces.**

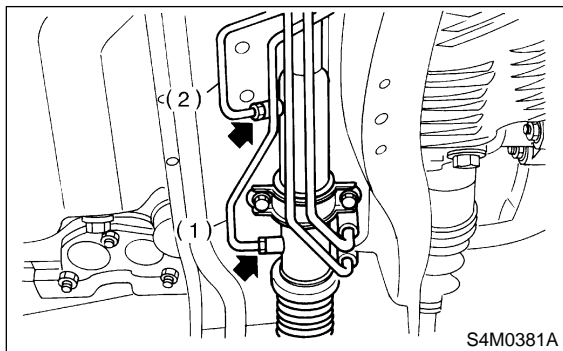

(1) Pipe A  
(2) Pipe B

- 4) Remove clamp E from pipes C and D.

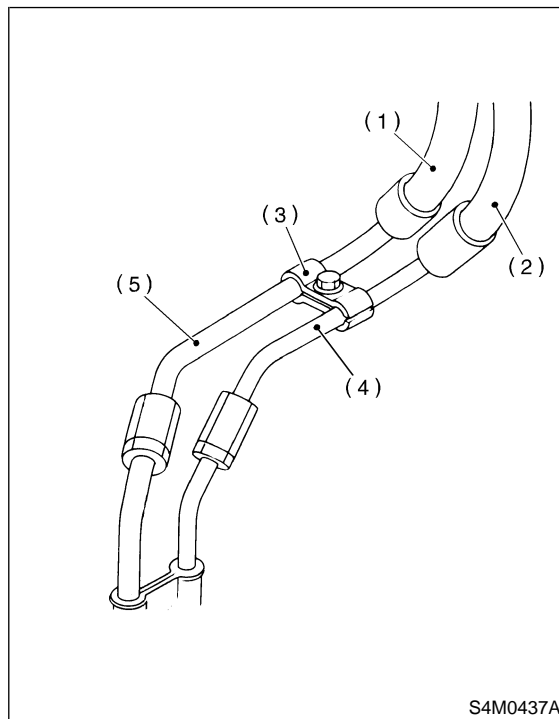

(1) Return hose  
(2) Pressure hose  
(3) Clamp E  
(4) Pipe C  
(5) Pipe D

- 5) Disconnect pipe C from pipe (on the gearbox side).

**CAUTION:**

- When disconnecting pipe C, use two wrenches to prevent deformities.
- Be careful to keep pipe connections free from foreign matter.

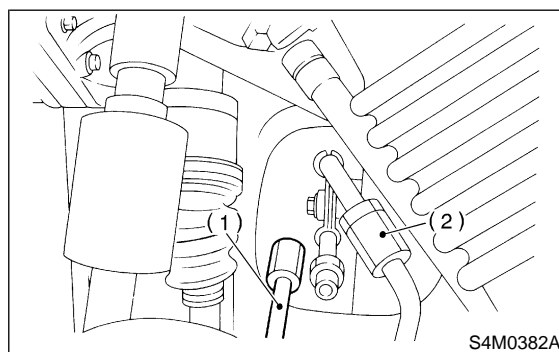

(1) Pipe C  
(2) Pipe D

6) Remove bolt A.  
Disconnect pipe C from oil pump. Disconnect pipe D from oil tank.

**CAUTION:**

- Do not allow fluid from the hose end to come into contact with pulley belt.
- To prevent foreign matter from entering the hose and pipe, cover the open ends of them with a clean cloth.

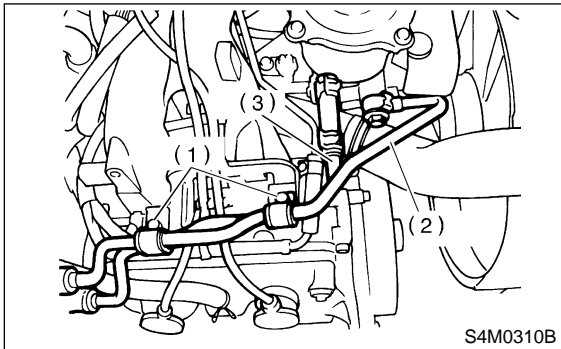

- (1) Bolt A
- (2) Pipe C
- (3) Pipe D

**B: CHECK**

Check all disassembled parts for wear, damage or other abnormalities. Repair or replace faulty parts as required.

Part name	Inspection	Remedy
Pipe	<ul style="list-style-type: none"> <li>● O-ring fitting surface for damage</li> <li>● Nut for damage</li> <li>● Pipe for damage</li> </ul>	Replace with new one.
Clamp B	<ul style="list-style-type: none"> <li>● Clamps for weak clamping force</li> </ul>	Replace with new one.
Clamp C		
Clamp E		
Hose	<ul style="list-style-type: none"> <li>● Flared surface for damage</li> <li>● Flare nut for damage</li> <li>● Outer surface for cracks</li> <li>● Outer surface for wear</li> <li>● Clip for damage</li> <li>● End coupling or adapter for degradation</li> </ul>	Replace with new one.

**C: INSTALLATION**

1) Connect pipes C and D to steering gearbox.

**Tightening torque:**

*Joint nut*

**15±5 N·m (1.5±0.5 kg-m, 10.8±3.6 ft-lb)**

**CAUTION:**

Visually check that hose between tank and pipe D is free from bending or twisting.

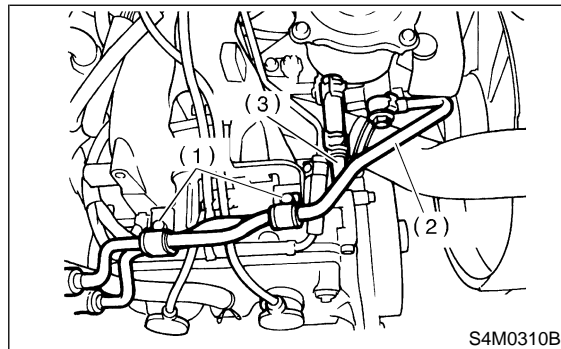

- (1) Bolt A
- (2) Pipe C
- (3) Pipe D

- 2) Connect pipe D to oil tank.
- 3) Connect pipe C to oil pump.

**CAUTION:**

Use a new gasket.

**Tightening torque:**

**39±5 N·m (4.0±0.5 kg-m, 28.9±3.6 ft-lb)**

4) Tighten bolt A.

**Tightening torque:**

**13±3 N·m (1.3±0.3 kg-m, 9.4±2.2 ft-lb)**

5) Temporarily connect pipes C and D to pipes (on the gearbox side).

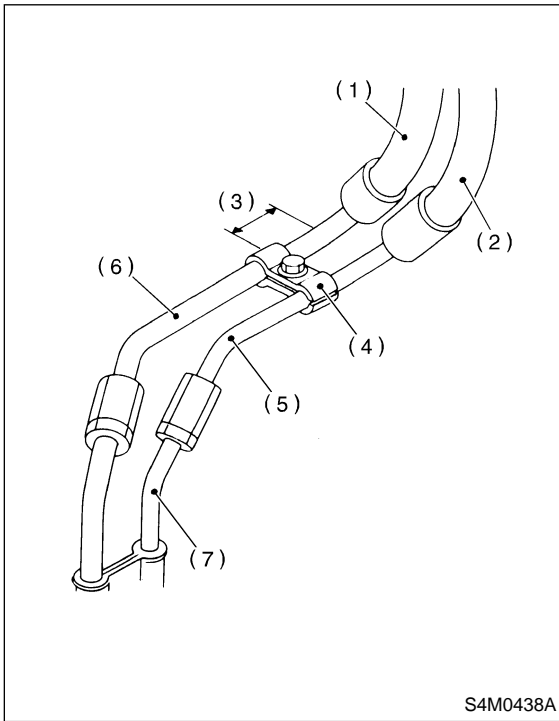

- (1) Return hose
- (2) Pressure hose
- (3) Approx. 30 mm (1.18 in)
- (4) Clamp E
- (5) Pipe C
- (6) Pipe D
- (7) Pipe (on gearbox side)

6) Temporarily install clamp E on pipes C and D.

**CAUTION:**  
Ensure that the letter “8” side of clamp E is on the pipe C side as shown in the figure.

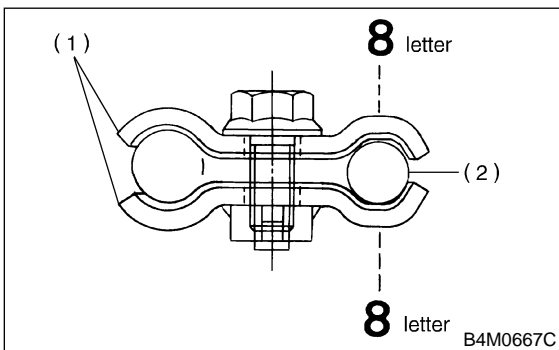

- (1) Clamp E
- (2) Pipe C

7) Tighten clamp E firmly.

**Tightening torque:**

**$7.4 \pm 2.0 \text{ N}\cdot\text{m}$  ( $0.75 \pm 0.20 \text{ kg}\cdot\text{m}$ ,  $5.4 \pm 1.4 \text{ ft}\cdot\text{lb}$ )**

8) Tighten joint nut.

**Tightening torque:**

**$15 \pm 5 \text{ N}\cdot\text{m}$  ( $1.5 \pm 0.5 \text{ kg}\cdot\text{m}$ ,  $10.8 \pm 3.6 \text{ ft}\cdot\text{lb}$ )**

9) Connect pipes A and B to the four pipe joints of gearbox. Connect upper pipe B first, and lower pipe A second.

**Tightening torque:**

**$13 \pm 3 \text{ N}\cdot\text{m}$  ( $1.3 \pm 0.3 \text{ kg}\cdot\text{m}$ ,  $9.4 \pm 2.2 \text{ ft}\cdot\text{lb}$ )**

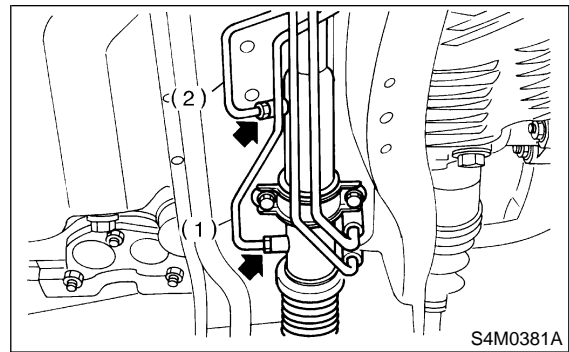

- (1) Pipe A
- (2) Pipe B

10) Install jack-up plate.

11) Connect battery minus terminal.

12) Feed the specified fluid and discharge air.

**NOTE:**

Never start the engine before feeding the fluid; otherwise vane pump might be seized up.

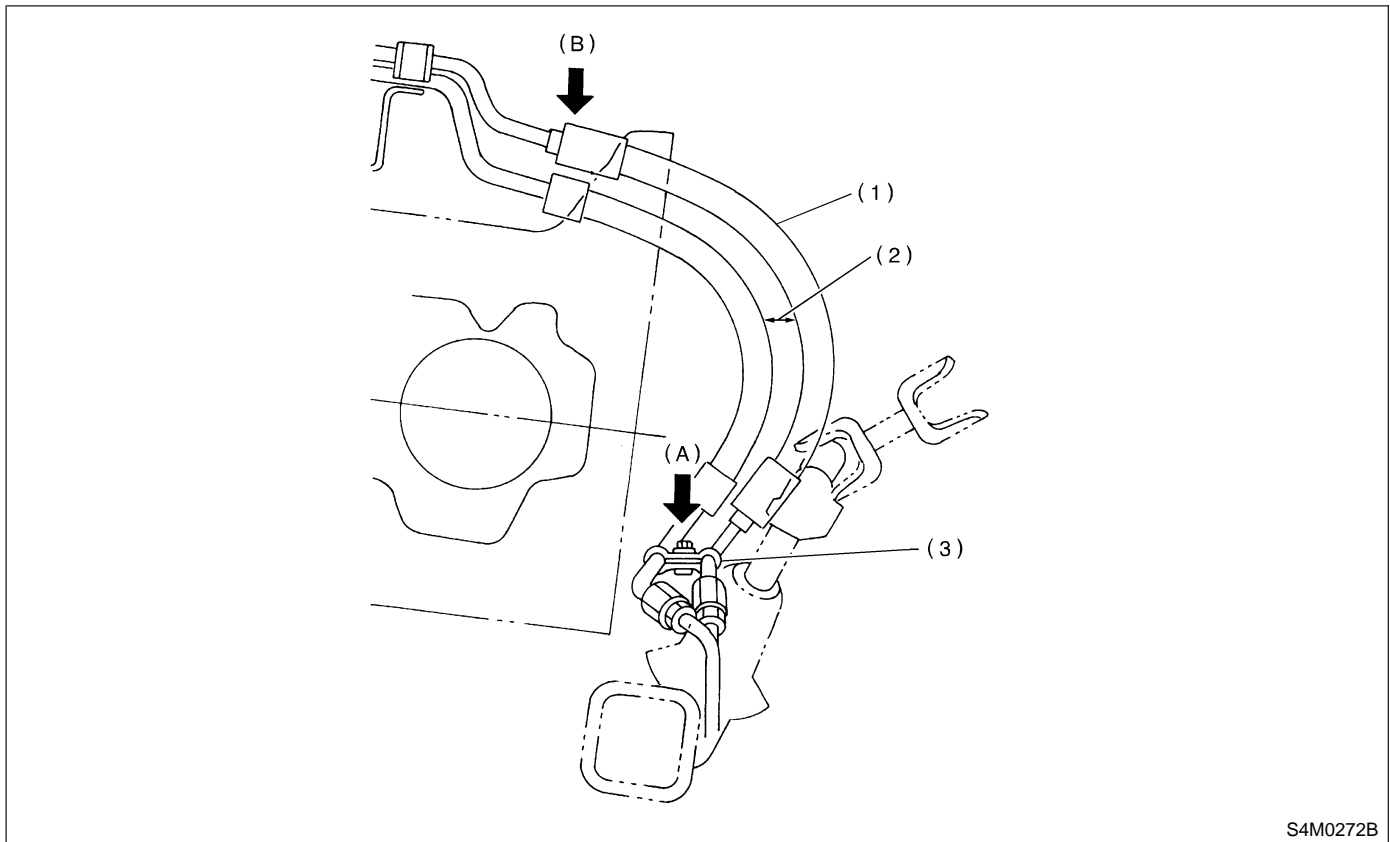

S4M0272B

- |   |   |
|---|---|
| (1) High-pressure hose                        | (3) Clearance between crossmember and pipe: 3 — 8 mm (0.12 — 0.31 in) |
| (2) No interference is allowed between hoses. |   |

13) Finally check clearance between pipes and/or hoses, as shown above.

If clearance between cruise control pump and power steering hose is less than 10 mm (0.39 in), proceed as follows:

- (1) Move clamped section (A) (refer to figure above.) down to a point where pipe is close to crossmember.

**Pipe-to-crossmember clearance:  
10 mm (0.39 in), min.**

- (2) Check that clearance between cruise control pump and power steering hose is at least 10 mm (0.39 in). If it is not, bend section (B) down until a clearance of at least 10 mm (0.39 in) is obtained.



## 6. Oil Pump (Power Steering System)

### A: REMOVAL

- 1) Remove ground cable from battery.
- 2) Drain the working fluid about 0.3 ℓ (0.3 US qt, 0.3 Imp qt) from oil tank.
- 3) Remove pulley belt cover bracket.
- 4) Loosen oil pump pulley nut, then remove bolts which secure generator.

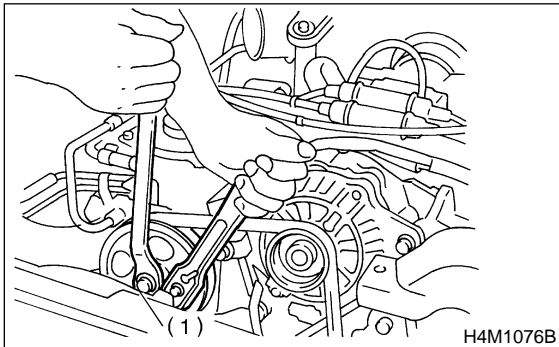

(1) Oil pump pulley nut

- 5) Loosen pulley belt(s).
- 6) Remove the nut and detach oil pump pulley.
- 7) Disconnect pipe C from oil pump. Disconnect pipe D from oil tank.

**CAUTION:**

- Do not allow fluid from the hose end to come into contact with pulley belt.
- To prevent foreign matter from entering the hose and pipe, cover the open ends of them with a clean cloth.
- Except when only oil tank needs to be inspected, detach oil tank and oil pump as a unit. Then separate one from the other on a work bench to prevent oil from spilling on any part of the engine.

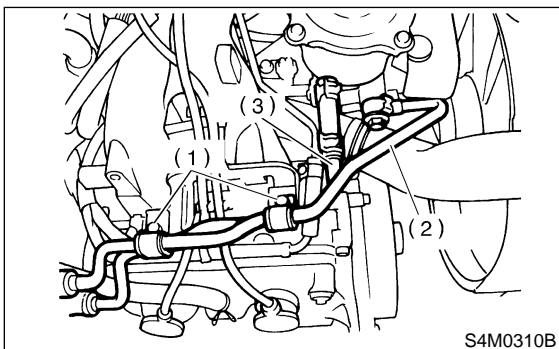

(1) Bolt A  
(2) Pipe C  
(3) Pipe D

- 8) Remove the three bolts from the front side of oil pump and detach the pump.

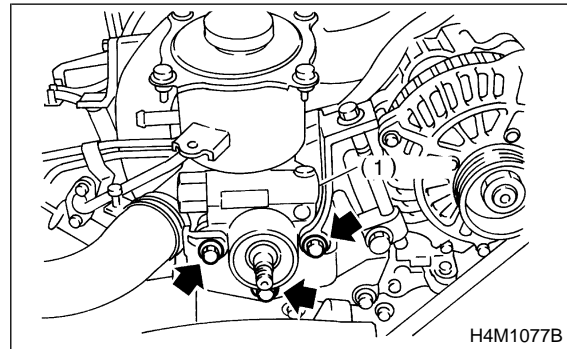

(1) Oil pump

- 9) Remove the three bolts from the lower side of bracket and detach the bracket.

**CAUTION:**

The bracket does not need to be removed unless it is damaged.

- 10) Place oil pump in a vise, and remove upper shell and baffle from lower shell.

**CAUTION:**

Do not clamp oil pump too hard; otherwise oil pump may be dented.

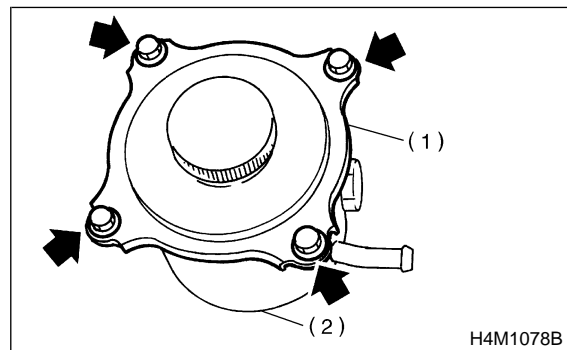

(1) Upper shell  
(2) Lower shell

- 11) Remove lower shell from oil pump.

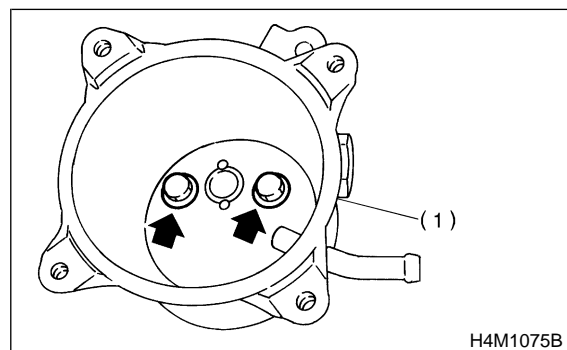

(1) Lower shell

**B: CHECK**

● In accordance with the following table, check all removed parts for wear and damage, and make repair or replacement if necessary.

No.	Parts	Inspection	Corrective action
1	Oil pump (Exterior)	(1) Crack, damage or oil leakage	Replace oil pump with a new one.
		(2) Play of pulley shaft	Measure radial play and axial play. If any of these exceeds the service limit, replace oil pump with a new one. <Ref. to 4-3 [W6B1].>
2	Pulley	(1) Damage	Replace it with a new one.
		(2) Bend	Measure V ditch deflection. If it exceeds the service limit, replace pulley with a new one. <Ref. to 4-3 [W6B1].>
3	Cap	Crack or damage	Replace it with a new one.
4	Strainer	(1) Clogging with dirt	Wash it.
		(2) Breakage	Replace it with a new one.
5	Oil pump (Interior)	(1) Defect or burning of vane pump	Check resistance to rotation of pulley. If it is past the service limit, replace oil pump with a new one. <Ref. to 4-3 [W6B1].>
		(2) Bend in the shaft or damage to bearing	Oil pump emits a noise that is markedly different in tone and loudness from a sound of a new oil pump when turning with a string put around its pulley, replace oil pump with a new one.
6	O-ring	Crack or deterioration	Replace it with a new one.
7	Oil tank	Crack, damage or oil leakage	Replace it with a new one.
8	Bracket	Crack	Replace it with a new one.

**1. SERVICE LIMIT**

Make a measurement as follows. If it exceeds the specified service limit, replace the parts with new ones.

**CAUTION:**

- Fix oil pump on a vise to make a measurement. At this time, hold oil pump with the least possible force between two wood pieces.
- Do not set outside of flow control valve or pulley on a vise; otherwise outside or pulley might be deformed. Select properly sized wood pieces.

- Play of pulley shaft

**On condition:**

**P: 9.8 N (1.0 kg, 2.2 lb)**

**Service limit:**

**Radial play (Direction ↔ )**  
**0.4 mm (0.016 in) or less**

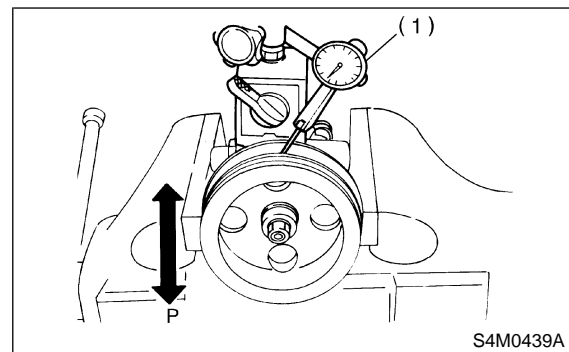

(1) Dial indicator

**Axial play (Direction  $\longleftrightarrow$  )**  
**0.9 mm (0.035 in) or less**

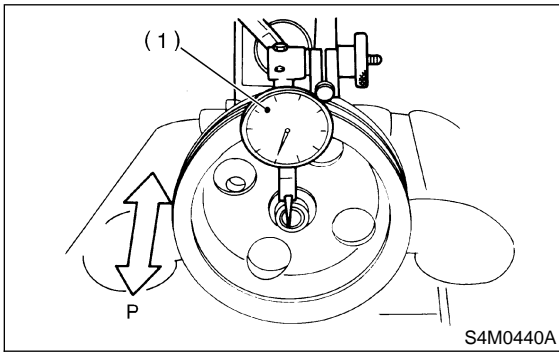

(1) Dial indicator

● **Ditch deflection of pulley**

**Service limit:**

**1.0 mm (0.039 in) or less**

**NOTE:**

Read the value for one surface of V ditch, and then the value for another off the dial.

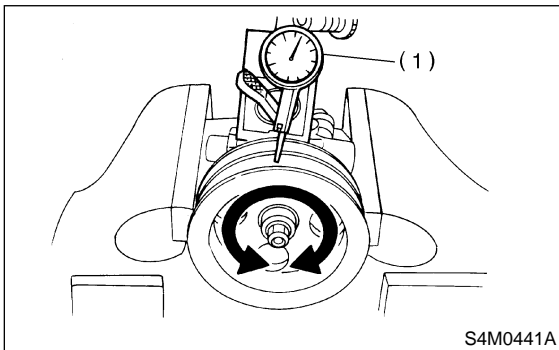

(1) Dial indicator

● **Resistance to rotation of pulley**

**Service limit:**

**Maximum load; 9.22 N (0.94 kg, 2.07 lb) or less**

**NOTE:**

- A rather higher value may be indicated when pulley starts turning.
- Measure the load during rotation and make a judgment.

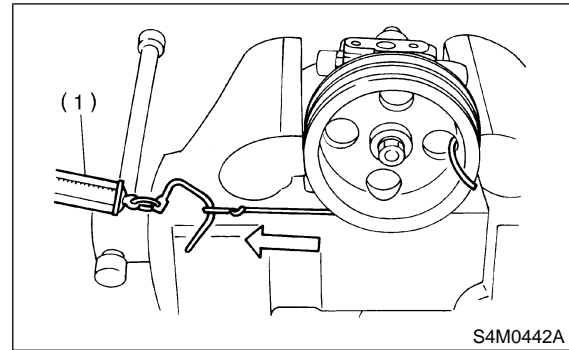

(1) Spring balance

**C: INSTALLATION**

- 1) Install bracket on engine.

**Tightening torque:**

**22±2 N·m (2.2±0.2 kg·m, 15.9±1.4 ft·lb)**

- 2) Install oil pump on oil tank as follows outside the vehicle:

**NOTE:**

Prior to installation, make sure that all oil is removed from oil pump, oil tank and pipe.

- (1) Place oil pump in a vise and install stay to oil pump.

**CAUTION:**

**Do not place oil pump directly in vise; use soft pads and hold oil pump lightly to protect it.**

**Tightening torque:**

**15.7±2.4 N·m (1.60±0.24 kg·m, 11.6±1.7 ft·lb)**

## 6. Oil Pump (Power Steering System)

(2) Install lower shell to oil pump.

**Tightening torque:**

$18^{+5}/_0$  N·m ( $1.8^{+0.5}/_0$  kg·m,  $13.0^{+3.6}/_0$  ft·lb)

**CAUTION:**

Be sure to use a new seal washer.

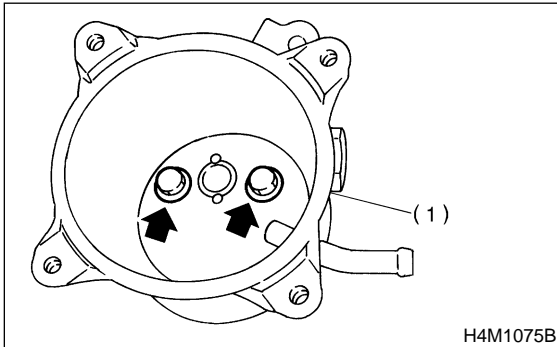

(1) Lower shell

(3) Install upper shell and baffle to lower shell.

**Tightening torque:**

$13\pm 3$  N·m ( $1.3\pm 0.3$  kg·m,  $9.4\pm 2.2$  ft·lb)

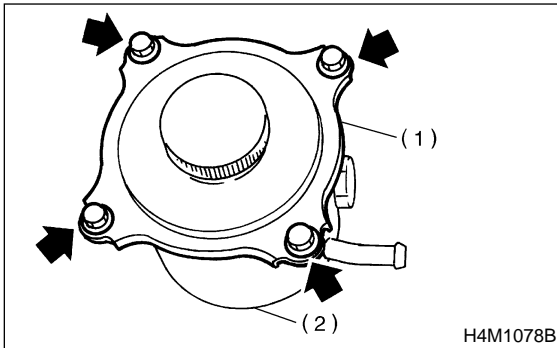

(1) Upper shell

(2) Lower shell

3) Install oil pump, previously assembled to oil tank, on bracket.

**Tightening torque:**

$18^{+5}/_0$  N·m ( $1.8^{+0.5}/_0$  kg·m,  $13.0^{+3.6}/_0$  ft·lb)

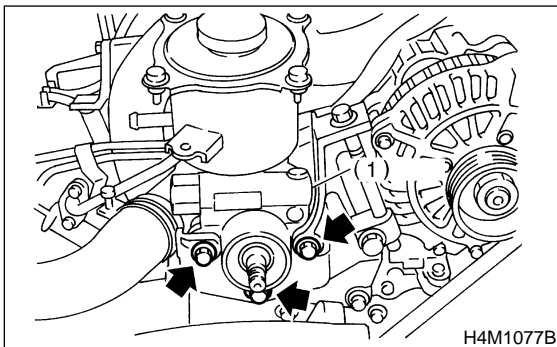

(1) Oil pump

4) Place oil pump pulley and tighten pulley nut temporarily.

5) Install pulley belt to oil pump.

6) Tighten oil pump pulley nut to the specified torque.

**Tightening torque:**

$52\pm 10$  N·m ( $5.3\pm 1.0$  kg·m,  $38\pm 7$  ft·lb)

7) Check pulley belt tension. <Ref. to 1-5 [G2A0].>

8) Tighten bolt belt tension.

**Tightening torque:**

$8\pm 2$  N·m ( $0.8\pm 0.2$  kg·m,  $5.8\pm 1.4$  ft·lb)

9) Interconnect pipes C and D.

**Tightening torque:****Eye bolt**

$39\pm 5$  N·m ( $4.0\pm 0.5$  kg·m,  $28.9\pm 3.6$  ft·lb)

**CAUTION:**

If a hose is twisted at this step, the hose may come into contact with some other parts.

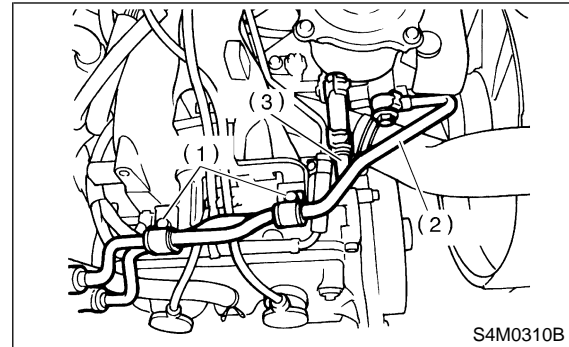

(1) Bolt A

(2) Pipe C

(3) Pipe D

10) Install pulley belt cover bracket.

11) Connect minus terminal of battery.

12) Feed the specified power steering fluid and discharge air. <Ref. to 4-3 [W7A0].>

**CAUTION:**

Never start the engine before feeding the fluid; otherwise vane pump might be seized up.

## 7. Power Steering Fluid

### A: RECOMMENDED POWER STEERING FLUID AND AIR BLEEDING

Recommended power steering fluid	Manufacturer
ATF DEXRON II, IIE or III	B.P.
	CALTEX
	CASTROL
	MOBIL
	SHELL
	TEXACO

- 1) Feed the specified fluid with its level being about 4 cm (1.6 in) lower than the mouth of tank.
- 2) Continue to turn steering wheel slowly from lock to lock until bubbles stop appearing in the tank while keeping the fluid at that level.
- 3) In case air is absorbed to deliver bubbles into piping because the fluid level is lower, leave it about half an hour and then do the previous step all over again.
- 4) Start, and idle the engine.
- 5) Continue to turn steering wheel slowly from lock to lock again until bubbles stop appearing in the tank while keeping the fluid at that level. It is normal that bubbles stop appearing after three times turning of steering wheel.
- 6) In case bubbles do not stop appearing in the tank, leave it about half an hour and then do the step 5) all over again.
- 7) Stop the engine, and take out safety stands after jacking up vehicle again. Then lower the vehicle, and idle the engine.
- 8) Continue to turn steering wheel from lock to lock until bubbles stop appearing and change of the fluid level is within 3 mm (0.12 in).
- 9) In case the following happens, leave it about half an hour and then do the previous step.
  - (1) The fluid level changes over 3 mm (0.12 in).
  - (2) Bubbles remain on the upper surface of the fluid.

- (3) Grinding noise is generated from oil pump.
- 10) Check the fluid leakage at flare nuts after turning steering wheel from lock to lock with engine running.

**CAUTION:**

- Before checking, wipe off any fluid on flare nuts, eye bolt and piping.
- In case the fluid leaks from flare nut, it is caused by dust (or the like) and/or damage between flare and tapered seat in piping.
- So remove the flare nut, tighten again it to the specified torque after cleaning flare and tapered seat. If flare or tapered seat is damaged, replace it with a new one.

- 11) Inspect fluid level on a flat and level surface with engine "OFF" by the indicator of filler cap. If the level is at lower point or below, add fluid to keep the level in the specified range of the indicator. If at upper point or above, drain fluid by using a syringe or the like.

**Fluid capacity:**

**0.7 ℓ (0.7 US qt, 0.6 Imp qt)**

- (1) Check at temperature 21°C (70°F) on reservoir surface of oil pump, read the fluid level on the "COLD" side.
- (2) Check at temperature 60°C (140°F) on reservoir surface of oil pump, read the fluid level on the "HOT" side.

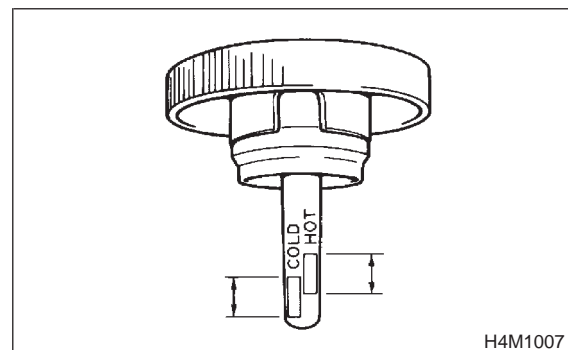

# 1. Power Steering

## A: STEERING CONDITION

Trouble	Possible cause	Corrective action
<ul style="list-style-type: none"> <li>● Heavy steering effort in all ranges</li> <li>● Heavy steering effort at stand still</li> <li>● Steering wheel surges when turning.</li> </ul>	1. Pulley belt <ul style="list-style-type: none"> <li>● Unequal length of pulley belts</li> <li>● Adhesion of oil and grease</li> <li>● Loose or damage of pulley belt</li> <li>● Poor uniformity of pulley belt cross section</li> <li>● Pulley belt touches to pulley bottom</li> <li>● Poor revolution of pulleys except oil pump pulley</li> <li>● Poor revolution of oil pump pulley</li> </ul>	Adjust or replace.
	2. Tire and rim <ul style="list-style-type: none"> <li>● Improper tires out of specification</li> <li>● Improper rims out of specification</li> <li>● Tires not properly inflated*1</li> </ul>	Replace or reinflate.
	3. Fluid <ul style="list-style-type: none"> <li>● Low fluid level</li> <li>● Aeration</li> <li>● Dust mix</li> <li>● Deterioration of fluid</li> <li>● Poor warming-up of fluid *2</li> </ul>	Refill, bleed air, replace or instruct customer.
	4. Idling speed <ul style="list-style-type: none"> <li>● Lower idling speed</li> <li>● Excessive drop of idling speed at start or at turning steering wheel *3</li> </ul>	Adjust or instruct customer.
	5. Measure hydraulic pressure. <Ref. to 4-3 [K1B0].>	Replace problem parts.
	6. Measure steering effort. <Ref. to 4-3 [K1C0].>	Adjust or replace.
<ul style="list-style-type: none"> <li>● Vehicle leads to one side or the other.</li> <li>● Poor return of steering wheel to center</li> <li>● Steering wheel surges when turning.</li> </ul>	1. Fluid line <ul style="list-style-type: none"> <li>● Folded hose</li> <li>● Flattened pipe</li> </ul>	Reform or replace.
	2. Tire and rim <ul style="list-style-type: none"> <li>● Flat tire</li> <li>● Mix use of different tires</li> <li>● Mix use of different rims</li> <li>● Abnormal wear of tire</li> <li>● Unbalance of remained grooves</li> <li>● Unbalance of tire pressure</li> </ul>	Fix or replace.
	3. Front alignment <ul style="list-style-type: none"> <li>● Improper or unbalance caster</li> <li>● Improper or unbalance toe-in</li> <li>● Loose connection of suspension</li> </ul>	Adjust or retighten.
	4. Others <ul style="list-style-type: none"> <li>● Damaged joint assembly</li> <li>● Unbalanced height</li> <li>● One-sided weight</li> </ul>	Replace, adjust or instruct customer.
	5. Measure steering effort. <Ref. to 4-3 [K1C0].>	Adjust or replace.

\*1 If tires and/or rims are wider, the load to power steering system is the more. Accordingly, in a condition, for example before fluid warms-up, relief valve may work before maximum turning angle. In this case, steering effort may be heavy. When measured hydraulic pressure is normal, there is no abnormal thing.

\*2 In cold weather, steering effort may be heavy due to increased flow resistance of cold fluid. After warming-up engine, turn steering wheel from stop to stop several times to warm-up fluid. Then if steering effort reduces normally, there is no abnormal thing.

\*3 In cold weather or with insufficient warm-up of engine, steering effort may be heavy due to excessive drop of idling when turning steering wheel. In this case, it is recommended to start the vehicle with increasing engine speed than usual. Then if steering effort reduces normally, there is no abnormal thing.

**B: MEASUREMENT OF HYDRAULIC PRESSURE****CAUTION:**

● Be sure to complete all items aforementioned in "STEERING CONDITION", prior to measuring hydraulic pressure. Otherwise, pressure can not be measured correctly. <Ref. to 4-3 [K1A0].>

● Do not leave the valve of pressure gauge closed or hold the steering wheel at stop end for 5 seconds or more in any case, as the oil pump may be damaged due to long keep of these conditions.

● Put a cotton cloth waste at a place where fluid drops before pressure gauge is installed. Wipe off split fluid thoroughly after the measurement.

**NOTE:**

Keep engine idling during the measurement.

**1B1 : MEASURE REGULAR PRESSURE.**

- 1) Install STs to power steering pump.
  - (1) Drain the power steering fluid about 0.35 ℓ (0.4 US qt, 0.3 Imp qt) from oil tank.
  - (2) Remove the two bolts securing power steering pipes to engine.
  - (3) Install ST1, 2 and 3 between power steering pump and pipes using gasket (Part No. 34621AC020) and bolt (Part No. 34620AC010).

ST1 925711000 PRESSURE GAUGE  
ST2 34099AC020 ADAPTER HOSE B  
ST3 34099AC010 ADAPTER HOSE A

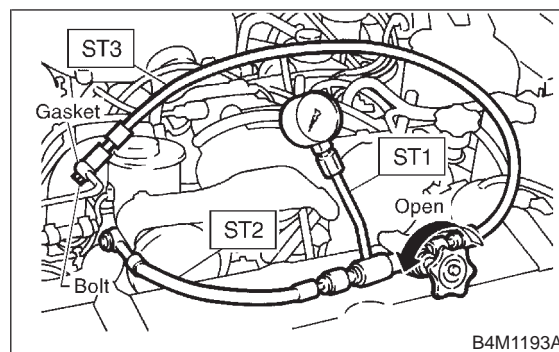

- (4) Replenish power steering fluid up to specified level.
- 2) Open valve, and start the engine.
- 3) Measure regular pressure.

**CHECK** : *Is pressure 981 kPa (10 kg/cm<sup>2</sup>, 142 psi) or less?*

**YES** : Go to step 1B2.

**NO** : Trouble may be due to crushed pipe or hose, leakage from fluid line, foreign particles in fluid line, etc. Replace faulty parts with new ones.

**1B2 : MEASURE RELIEF PRESSURE.**

1) Using STs, measure relief pressure.

ST1 925711000 PRESSURE GAUGE  
 ST2 34099AC020 ADAPTER HOSE B  
 ST3 34099AC010 ADAPTER HOSE A

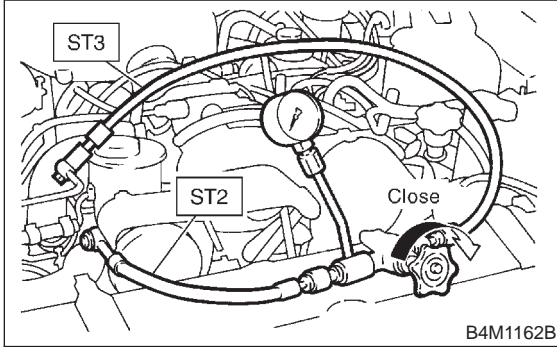

2) Close valve.

- CHECK** : Is pressure 7,159 — 7,748 kPa (73 — 79 kg/cm<sup>2</sup>, 1,038 — 1,123 psi)?
- YES** : Go to step 1B3.
- NO** : Trouble may be due to malfunctioning relief valve, fluid leaking into oil pump interior, abnormal wear of pump vanes, etc. Replace with new oil pump.

**1B3 : MEASURE WORKING PRESSURE.**

1) Using STs, measure working pressure.

ST1 925711000 PRESSURE GAUGE  
 ST2 34099AC020 ADAPTER HOSE B  
 ST3 34099AC010 ADAPTER HOSE A

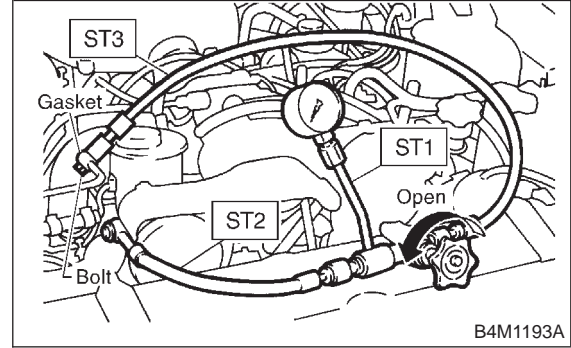

2) Open valve.

3) Measure working pressure of control valve by turning wheel from stop to stop.

- CHECK** : Is pressure 7,159 — 7,748 kPa (73 — 79 kg/cm<sup>2</sup>, 1,038 — 1,123 psi)?
- YES** : Measure steering force. <Ref. to 4-3 [K1C0].>
- NO** : Control valve is inoperative. Replace control valve itself or control valve and pinion as a single unit with new ones.



C: MEASUREMENT OF STEERING EFFORT

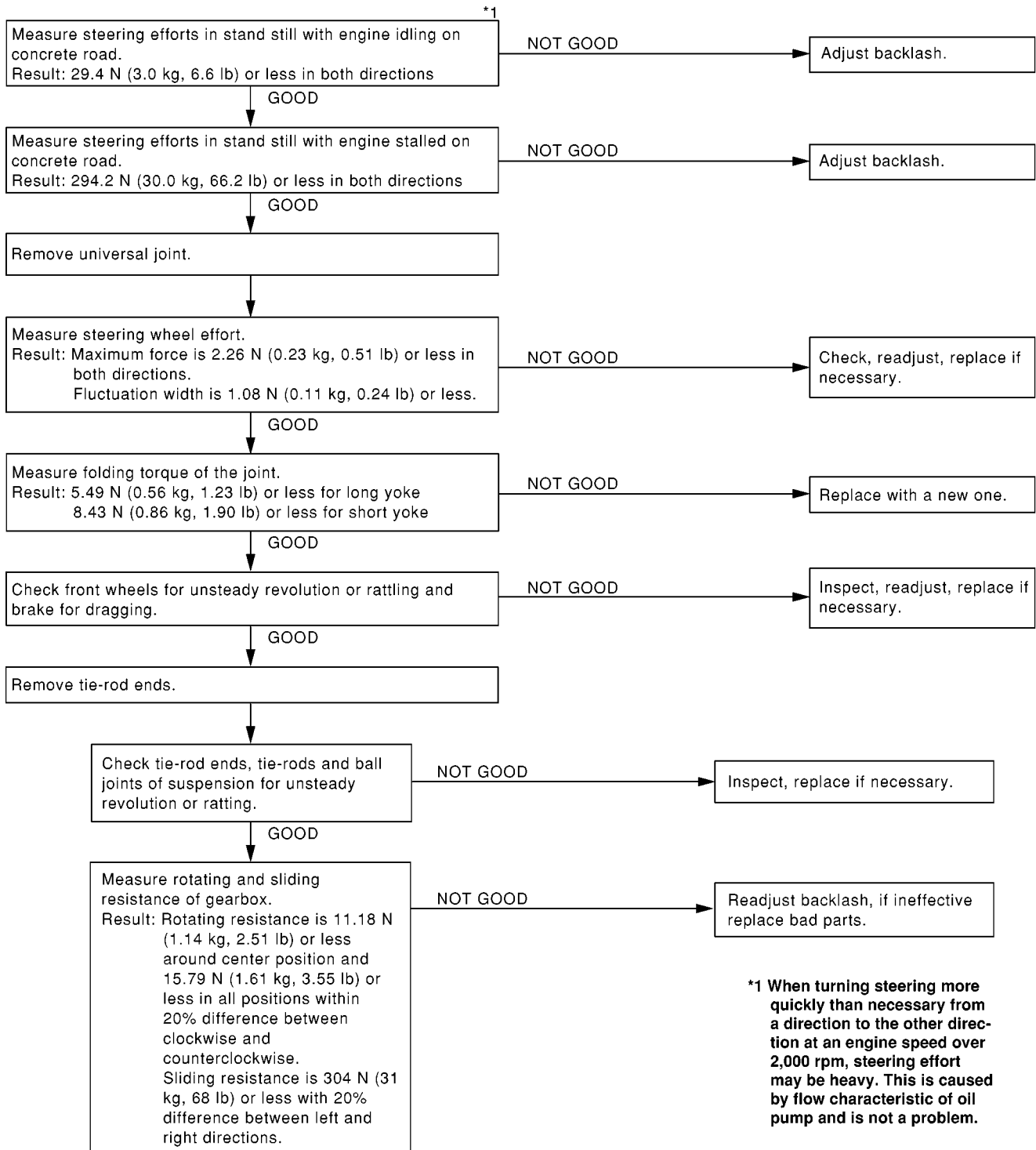

**\*1 When turning steering more quickly than necessary from a direction to the other direction at an engine speed over 2,000 rpm, steering effort may be heavy. This is caused by flow characteristic of oil pump and is not a problem.**

1. Power Steering

1) Measurement of steering effort is as shown in the figures.

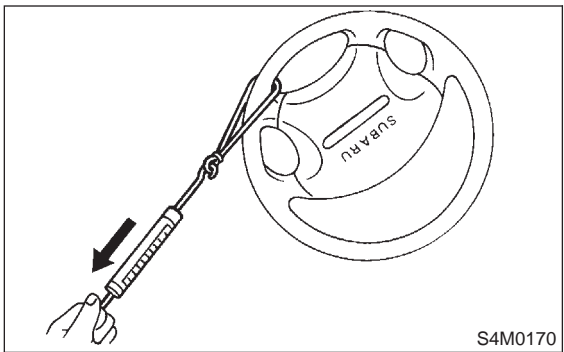
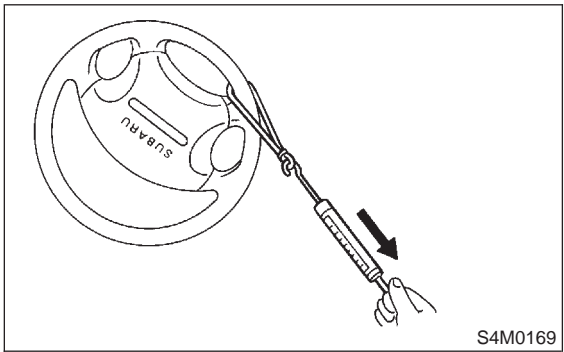

2) Measurement of folding torque of universal joint is as shown in the figures.

**Service limit:**

**Maximum load; 5.49 N (0.56 kg, 1.23 lb) or less**

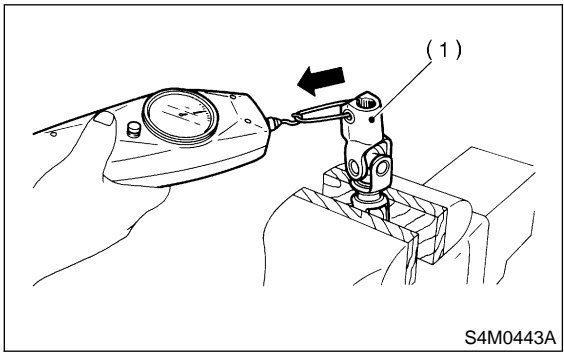

(1) Long yoke

**Service limit:**

**Maximum load; 5.49 N (0.56 kg, 1.23 lb) or less**

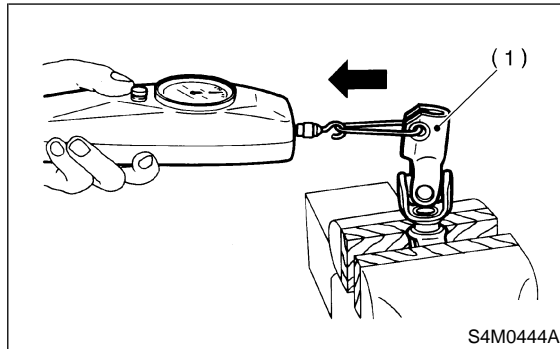

(1) Long yoke

**Service limit:**

**Maximum load; 8.43 N (0.86 kg, 1.90 lb) or less**

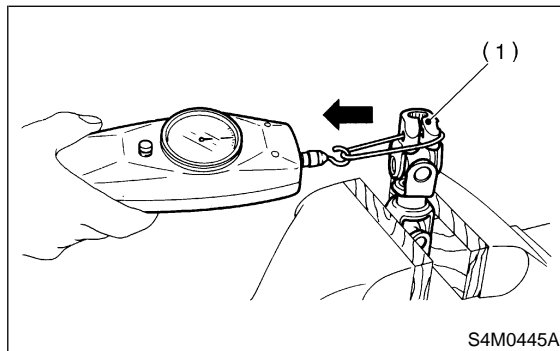

(1) Short yoke

**Service limit:**

**Maximum load; 8.43 N (0.86 kg, 1.90 lb) or less**

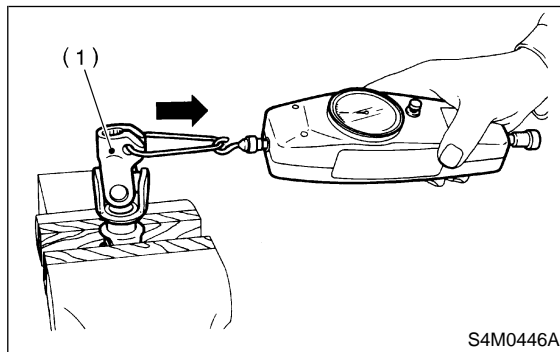

(1) Short yoke

3) Using ST, measure resistances of gearbox.  
ST 926230000 SPANNER

**Rotating resistance:**

**Straight-ahead position within 30 mm (1.18 in) from rack center;**

**Less than 11.18 N (1.14 kg, 2.51 lb)**

**Maximum allowable torque;**

**15.7 N (1.6 kg, 3.5 lb)**

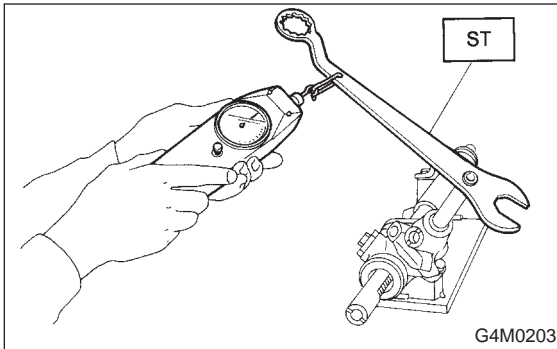

**Sliding resistance:**

**Right-turn steering;**

**304 N (31 kg, 68 lb) or less**

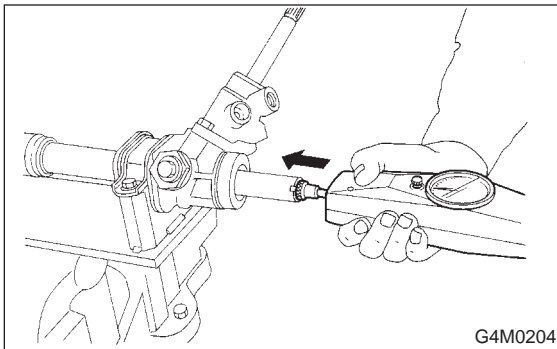

**Left-turn steering;**

**304 N (31 kg, 68 lb) or less**

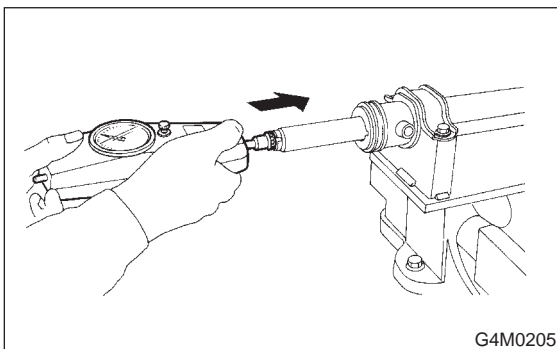

**D: FLUID LEAKAGE**

**CAUTION:**

It is likely that although one judges fluid leakage, there is actually no leakage. This is because the fluid spilt during the last maintenance was not completely wiped off. Be sure to wipe off spilt fluid thoroughly after maintenance.

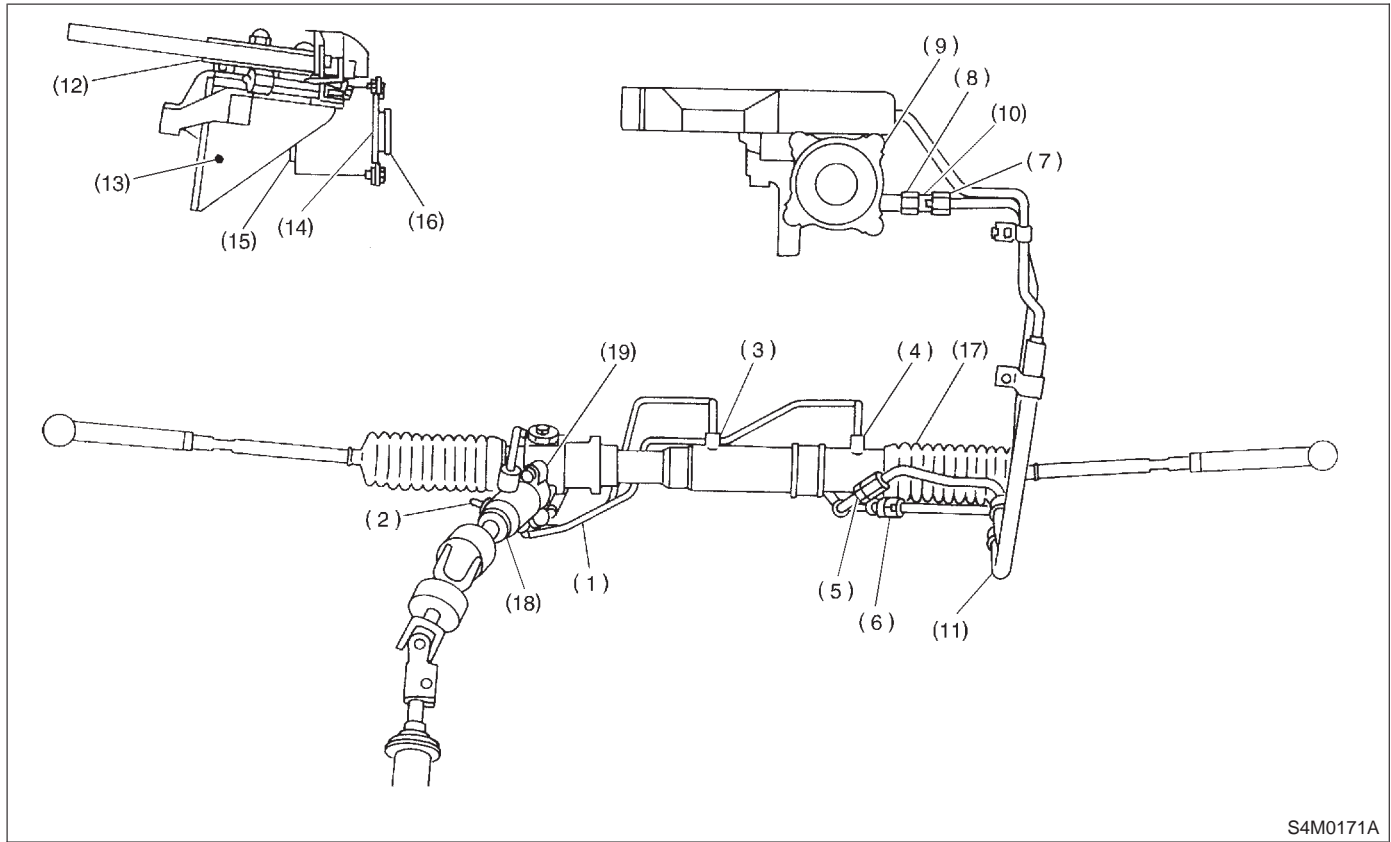

S4M0171A

Fluid leaking area	Possible cause	Corrective action
Leakage from connecting portions of pipes and hoses, numbered with (1) through (9) in figure	Insufficient tightening of flare nut, catching dirt or the like, damage to flare or flare nut or eye bolt	Loosen and retighten, if ineffective, replace.
	Poor insertion of hose, poor clamping	Retighten or replace clamp.
	Damaged O-ring or gasket	Replace O-ring or gasket pipe or hose with new one, if ineffective, replace gear-box also.
Leakage from hose (10) and (11) in figure	Crack or damage in hose	Replace with a new one.
	Crack or damage in hose hardware	Replace with a new one.
Leakage from surrounding of cast iron portion of oil pump (12) and (13) in figure	Damaged O-ring	Replace oil pump.
	Damaged gasket	Replace oil pump.
Leakage from oil tank (14) and (15) in figure	Crack in oil tank, (14)	Replace oil tank.
	Damaged O-ring, (15)	Replace O-ring.
Leakage from filler neck (16)	Damaged cap packing	Replace cap.
	Crack in root of filler neck	Replace oil tank.
	High fluid level *1	Adjust fluid level.
Leakage from surrounding of power cylinder of gearbox (17) in figure	Damaged oil seal	Replace oil seal.
Leakage from control valve of gear-box (18) and (19) in figure	Damaged packing or oil seal	Replace problem parts.
	Damage in control valve	Replace control valve.

**NOTE:**

Fluid level is specified at optimum position (range) for ordinary use. Accordingly, if the vehicle is used often under hard conditions such as on very rough roads or in mountainous areas, fluid may bleed out from cap air vent hole. This is not a problem. If a customer complains strongly and is not likely to be satisfied with the leakage, lower the fluid level to the extent that fluid will not bleed out under the conditions described, and have the customer check the fluid level and its quality more frequently than usual.

**E: NOISE AND VIBRATION****CAUTION:**

**Don't keep the relief valve operated over 5 seconds at any time or inner parts of the oil pump may be damaged due to rapid increase of fluid temperature.**

**NOTE:**

- Grinding noise may be heard immediately after the engine start in extremely cold condition. In this case, if the noise goes off during warm-up there is no abnormal function in the system. This is due to the fluid characteristic in extremely cold condition.

- Oil pump makes whine or growl noise slightly due to its mechanism. Even if the noise can be heard when steering wheel is turned at stand still there is no abnormal function in the system provided that the noise eliminates when the vehicle is running.

- When stopping with service brake and/or parking brake applied, power steering can be operated easily due to its light steering effort. If doing so, the disk rotates slightly and makes creaking noise. The noise is generated by creaking between the disk and pads. If the noise goes off when the brake is released, there is no abnormal function in the system.

- There may be a little vibration around the steering devices when turning steering wheel at standstill, even though the component parts are properly adjusted and have no defects.

Hydraulic systems are likely to generate this kind of vibration as well as working noise and fluid noise because of combined conditions, i.e., road surface and tire surface, engine speed and turning speed of steering wheel, fluid temperature and braking condition.

This phenomena does not indicate there is some abnormal function in the system.

The vibration can be known when steering wheel is turned repeatedly at various speeds from slow to rapid step by step with parking brake applied on concrete road and in "D" range for automatic transmission vehicle.

Trouble	Possible cause	Corrective action
Hiss noise (continuous) While engine is running.	Relief valve emits operating sound when steering wheel is completely turned in either direction. (Don't keep this condition over 5 seconds.)	Normal
	Relief valve emits operating sound when steering wheel is not turned. This means that the relief valve is faulty.	Defective Replace oil pump.
Rattling noise (intermittent) While engine is running.	Interference with adjacent parts	Check clearance. Correct if necessary. <Ref. to 4-3 [K1F0].>
	Loosened installation of oil pump, oil tank, pump bracket, gearbox or crossmember	Retighten.
	Loosened installation of oil pump pulley or other pulley(s)	Retighten.
	Loosened linkage or play of steering or suspension Loosened tightening of joint or steering column	Retighten or replace.
	Sound generates from the inside of gearbox or oil pump.	Replace bad parts of the gearbox or oil pump.
Knocking When turning steering wheel in both direction with small angle repeatedly at engine ON or OFF.	Excessive backlash Loosened lock nut for adjusting backlash	Adjust and retighten.
	Loosened tightening or play of tie-rod, tie-rod end	Retighten or replace.
Grinding noise (continuous) While engine is running.	Vane pump aeration	Inspect and retighten fluid line connection. Refill fluid and vent air.
	Vane pump seizing	Replace oil pump.
	Pulley bearing seizing of oil pump	Replace oil pump.
	Folded hose, flat pipe	Replace.
Squeal, squeak (intermittent or continuous) While engine is running.	Maladjustment of pulley belt Damaged or charged pulley belt Unequal length of pulley belts	Adjust or replace. (Replace the two belts as a set.)
	Run out or soilage of V-groove surface of oil pump pulley	Clean or replace.
Sizzling noise (continuous) While engine is running.	Fluid aeration	Fix wrong part causing aeration. Replace fluid and vent air.
	Damaged pipe of gearbox	Replace pipe.
	Abnormal inside of hose or pipe Flat hose or pipe	Rectify or replace.
	Abnormal inside of oil tank	Replace.
	Removed oil tank cap	Install cap.
Whistle (continuous) While engine is running.	Abnormal pipe of gearbox or abnormal inside of hose	Replace bad parts of gearbox or hose.
Whine or growl (continuous or intermittent) While engine is running with/without steering turned.	Loosened installation of oil pump, oil pump bracket	Retighten.
	Abnormal inside of oil pump, hose	Replace oil pump, hose, if the noise can be heard when running as well as stand still.
	Torque converter growl, air conditioning compression growl	Remove power steering pulley belt and confirm.
Creaking noise (intermittent) While engine is running with steering turned.	Abnormal inside of gearbox	Replace bad parts of gearbox.
	Abnormal bearing for steering shaft	Apply grease or replace.
	Generates when turning steering wheel with brake (service or parking) applied.	If the noise goes off when brake is released, it is normal.
Vibration While engine is running with/without steering turned.	Too low engine speed at start	Adjust and instruct customers.
	Vane pump aeration	Fix wrong part. Vent air.
	Damaged valve in oil pump, gearbox	Replace oil pump, bad parts of gearbox.
	Looseness of play of steering, suspension parts	Retighten.

**F: CLEARANCE TABLE**

**CAUTION:**

This table lists various clearances that must be correctly adjusted to ensure normal vehicle driving without interfering noise, or any other faults.

Location	Minimum allowance
(1) Crossmember — Pipe	5 mm (0.20 in)
(2) DOJ — Shaft or joint	14 mm (0.55 in)
(3) DOJ — Valve housing	11 mm (0.43 in)
(4) Pipe — Pipe	2 mm (0.08 in)
(5) Stabilizer — Pipe	5 mm (0.20 in)
(6) Exhaust pipe — Pipe	15 mm (0.59 in)
(7) Exhaust pipe — Gearbox bolt	15 mm (0.59 in)
(8) Side frame — Hose A and B	15 mm (0.59 in)
(9) Cruise control pump — Hose A and B	15 mm (0.59 in)
(10) Pipe portion of hose A — Pipe portion of hose B	1.5 mm (0.059 in)
(11) AT cooling hose — Joint	20 mm (0.79 in)

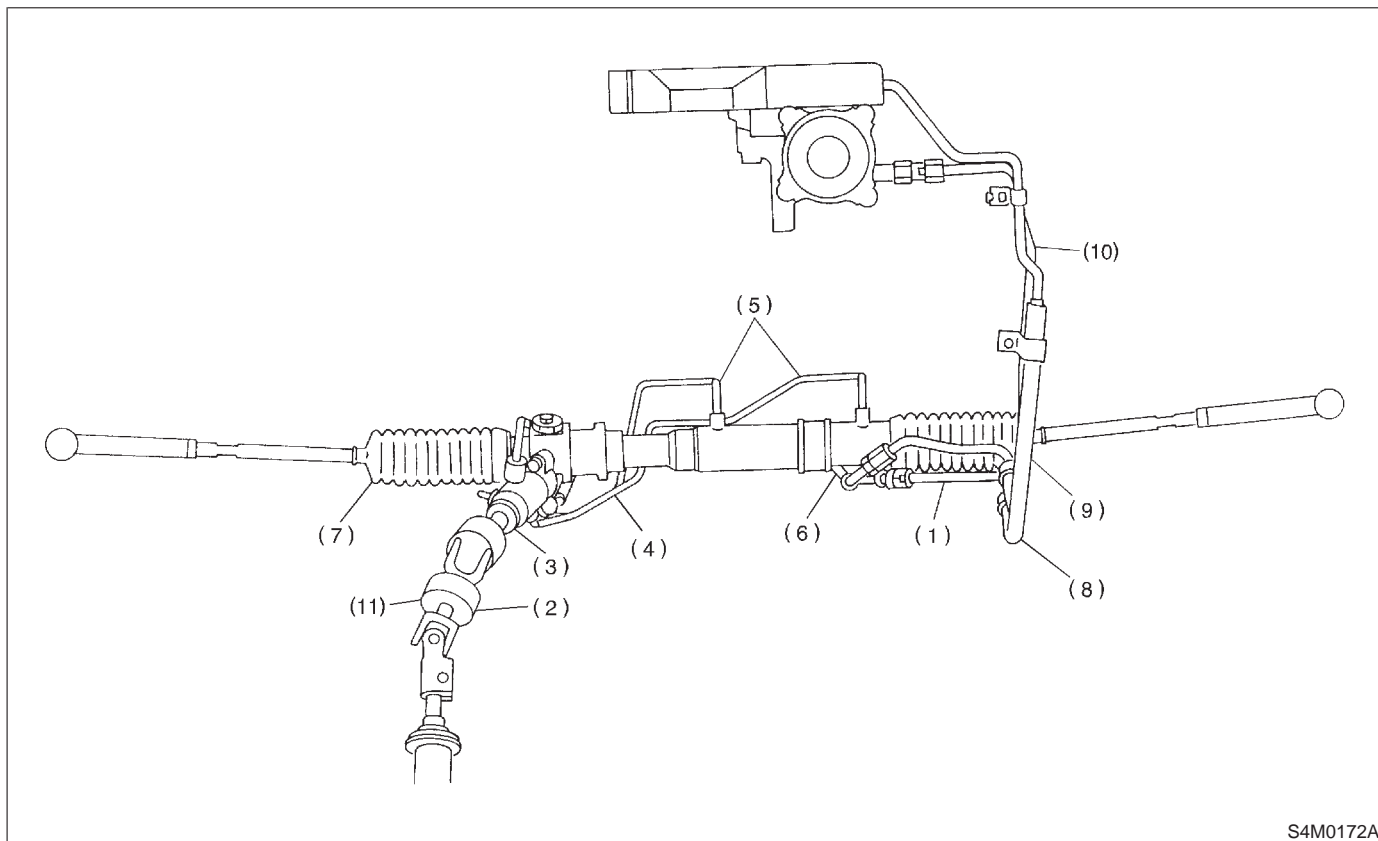

S4M0172A

**G: BREAKAGE OF HOSES**

**CAUTION:**

Although surface layer materials of rubber hoses have excellent weathering resistance, heat resistance and resistance for low temperature brittleness, they are likely to be damaged chemically by brake fluid, battery electrolyte, engine oil and automatic transmission fluid and their service lives are to be very shortened. It is very important to keep the hoses free from before mentioned fluids and to wipe out immediately when the hoses are adhered with the fluids.

Since resistances for heat or low temperature brittleness are gradually declining according to time accumulation of hot or cold conditions for

the hoses and their service lives are shortening accordingly, it is necessary to perform careful inspection frequently when the vehicle is used in hot weather areas, cold weather area and/or a driving condition in which many steering operations are required in short time.

Particularly continuous work of relief valve over 5 seconds causes to reduce service lives of the hoses, the oil pump, the fluid, etc. due to over heat.

So, avoid to keep this kind of condition when servicing as well as driving.

Trouble	Possible cause	Corrective action
Pressure hose burst	Excessive holding time of relief status	Instruct customers.
	Malfunction of relief valve	Replace oil pump.
	Poor cold characteristic of fluid	Replace fluid.
Forced out return hose	Poor connection	Correct.
	Poor holding of clip	Retighten.
	Poor cold characteristic of fluid	Replace fluid.
Fluid bleeding out of hose slightly	Wrong layout, tensioned	Replace hose.
	Excessive play of engine due to deterioration of engine mounting rubber	Replace defective parts.
	Improper stop position of pitching stopper	Replace defective parts.
Crack on hose	Excessive holding time of relief status	Replace. Instruct customer.
	Excessive tightening torque for return hose clip	Replace.
	Power steering fluid, brake fluid, engine oil, electrolyte adhere on the hose surface	Replace. Pay attention on service work.
	Too many times use in extremely cold weather	Replace. Instruct customers.



## 1. Brakes

## A: SPECIFICATIONS

Engine (cc)		2500	
Driving system		AWD	
		L	S
Front disc brake	Type	Disc (Floating type, ventilated)	
	Effective disc diameter	mm (in)	228 (8.98)
	Disc thickness × Outer diameter	mm (in)	24 × 277 (0.94 × 10.91)
	Effective cylinder diameter	mm (in)	42.8 (1.685) × 2
	Pad dimensions (length × width × thickness)	mm (in)	112.3 × 50.0 × 11.0 (4.42 × 1.969 × 0.433)
	Clearance adjustment	Automatic adjustment	
Rear disc brake	Type	—	Disc (Floating type)
	Effective disc diameter	mm (in)	230 (9.06)
	Disc thickness × Outer diameter	mm (in)	10 × 266 (0.39 × 10.47)
	Effective cylinder diameter	mm (in)	38.1 (1.500)
	Pad dimensions (length × width × thickness)	mm (in)	82.4 × 33.7 × 9.0 (3.244 × 1.327 × 0.354)
	Clearance adjustment	—	Automatic adjustment
Rear drum brake	Type	Drum (Leading-Trailing type)	—
	Effective drum diameter	mm (in)	228.6 (9)
	Effective cylinder diameter	mm (in)	19.0 (0.748)
	Lining dimensions (length × width × thickness)	mm (in)	218.8 × 35.0 × 4.1 (8.61 × 1.378 × 0.161)
	Clearance adjustment	Automatic adjustment	
Parking brake	Type	Mechanical on rear brakes, drum in disc	
	Effective drum diameter	mm (in)	228.6 (9) 170 (6.69)
	Lining dimensions (length × width × thickness)	mm (in)	218.8 × 35.0 × 4.1 (8.61 × 1.378 × 0.161) 162.6 × 30.0 × 3.2 (6.40 × 1.181 × 0.126)
	Clearance adjustment	Automatic adjustment	Manual adjustment
Master cylinder	Type	Tandem	
	Effective diameter	mm (in)	26.99 (1-1/16)
	Reservoir type	Sealed type	
	Brake fluid reservoir capacity	cm <sup>3</sup> (cu in)	205 (12.51)
Brake booster	Type	Vacuum suspended	
	Effective diameter	mm (in)	205 + 230 (8.07 + 9.06)
Proportioning valve	Split point	kPa (kg/cm <sup>2</sup> , psi) 3,678 (37.5, 533)	
	Reducing ratio	0.3	
Brake line	Dual circuit system		
ABS	STD		

**B: SERVICE DATA**

ITEM		STANDARD	SERVICE LIMIT
Front brake	Pad thickness (including back metal)	17 mm (0.67 in)	7.5 mm (0.295 in)
	Disc thickness	24 mm (0.94 in)	22 mm (0.87 in)
	Disc runout	—	0.075 mm (0.0030 in)
Rear brake (Disc type)	Pad thickness (including back metal)	14 mm (0.55 in)	6.5 mm (0.256 in)
	Disc thickness	10 mm (0.39 in)	8.5 mm (0.335 in)
	Disc runout	—	0.07 mm (0.0028 in)
Rear brake (Drum type)	Inside diameter	228.6 mm (9 in)	230.6 mm (9.08 in)
	Lining thickness	4.1 mm (0.161 in)	1.5 mm (0.059 in)
Rear brake (Disc type parking)	Inside diameter	170 mm (6.69 in)	171 mm (6.73 in)
	Lining thickness	3.2 mm (0.126 in)	1.5 mm (0.059 in)
Parking brake	Lever stroke	7 to 8 notches/196 N (20 kg, 44 lb)	

Brake booster	Brake fluid pressure without engine running	Brake pedal force	Fluid pressure
		147 N (15 kg, 33 lb)	588 kPa (6 kg/cm <sup>2</sup> , 85 psi)
	294 N (30 kg, 66 lb)	1,765 kPa (18 kg/cm <sup>2</sup> , 256 psi)	
	Brake fluid pressure with engine running and vacuum at 66.7 kPa (500 mmHg, 19.69 inHg)	Brake pedal force	Fluid pressure
147 N (15 kg, 33 lb)	5,590 kPa (57 kg/cm <sup>2</sup> , 811 psi)		
294 N (30 kg, 66 lb)	9,807 kPa (100 kg/cm <sup>2</sup> , 1,422 psi)		

**C: RECOMMENDED BRAKE FLUID**

FMVSS No. 116, fresh DOT3 or 4 brake fluid

**CAUTION:**

- Avoid mixing brake fluid of different brands to prevent the fluid performance from degrading.
- When brake fluid is supplemented, be careful not to allow any dust into the reservoir.
- Use fresh DOT3 or 4 brake fluid when replacing or refilling the fluid.

**D: BRAKE FLUID LEVEL INDICATOR**

*Reserve tank with level indicator:*

*Residual fluid quantity at light ON*

*Approx. 80 cm<sup>3</sup> (4.88 cu in)*

*Tank capacity*

*205 cm<sup>3</sup> (12.51 cu in)*

1. Front Disc Brake

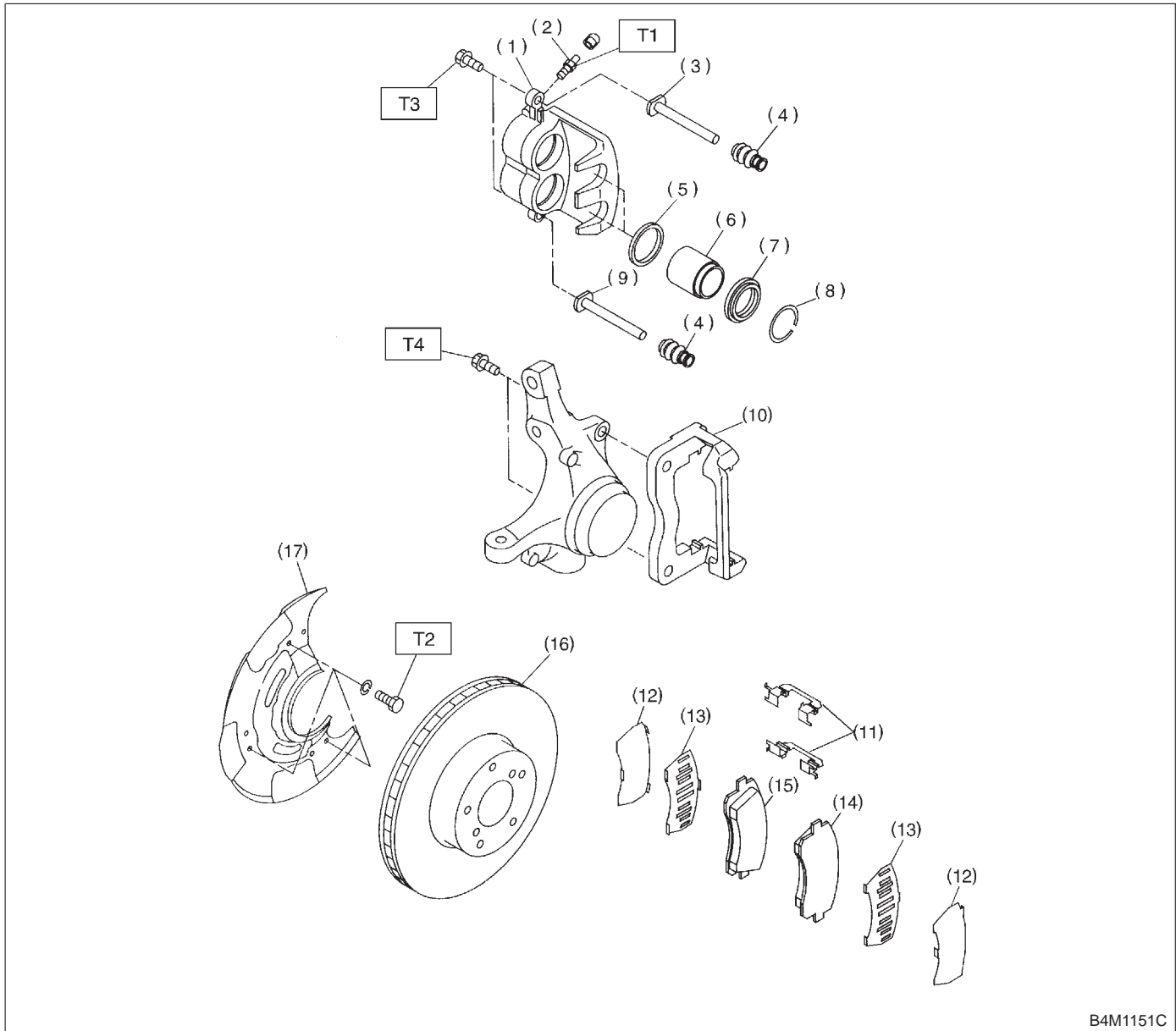

B4M1151C

- (1) Caliper body
- (2) Air bleeder screw
- (3) Guide pin (Green)
- (4) Pin boot
- (5) Piston seal
- (6) Piston
- (7) Piston boot
- (8) Boot ring

- (9) Lock pin (Yellow)
- (10) Support
- (11) Pad clip
- (12) Outer shim
- (13) Inner shim
- (14) Pad (Outside)
- (15) Pad (Inside)
- (16) Disc rotor

- (17) Disc cover

**Tightening torque: N-m (kg-m, ft-lb)**

**T1: 8±1 (0.8±0.1, 5.8±0.7)**

**T2: 18±5 (1.8±0.5, 13.0±3.6)**

**T3: 37±5 (3.8±0.5, 27.5±3.6)**

**T4: 78±10 (8.0±1.0, 58±7)**

2. Rear Disc Brake

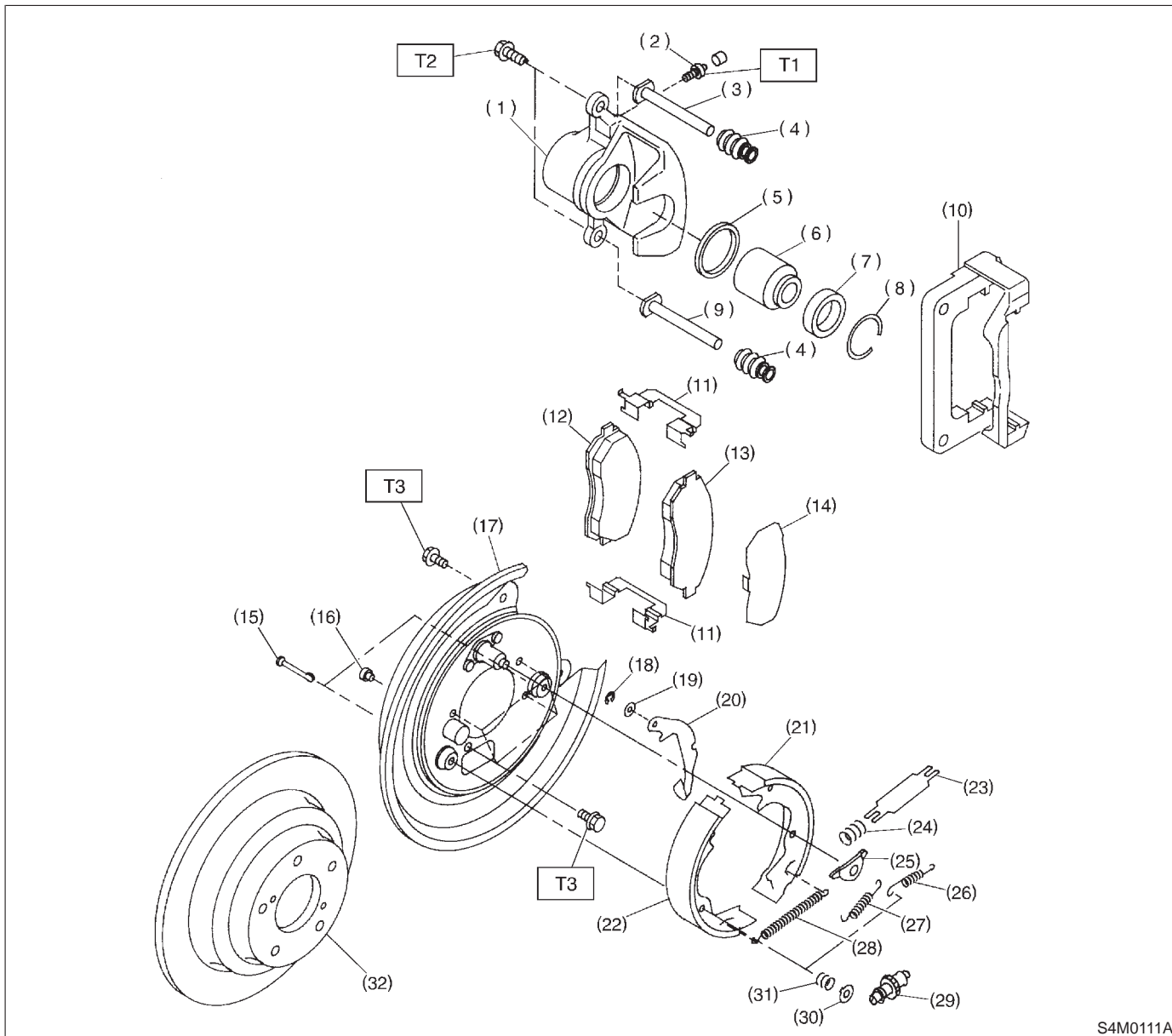

- |                       |                                     |                                 |
|-----------------------|-------------------------------------|---------------------------------|
| (1) Caliper body      | (14) Shim                           | (27) Primary shoe return spring |
| (2) Air bleeder screw | (15) Shoe hold-down pin             | (28) Adjusting spring           |
| (3) Guide pin (Green) | (16) Cover                          | (29) Adjuster                   |
| (4) Pin boot          | (17) Back plate                     | (30) Shoe hold-down cup         |
| (5) Piston seal       | (18) Retainer                       | (31) Shoe hold-down spring      |
| (6) Piston            | (19) Spring washer                  | (32) Disc rotor                 |
| (7) Piston boot       | (20) Parking brake lever            |                                 |
| (8) Boot ring         | (21) Parking brake shoe (Secondary) |                                 |
| (9) Lock pin (Yellow) | (22) Parking brake shoe (Primary)   |                                 |
| (10) Support          | (23) Strut                          |                                 |
| (11) Pad clip         | (24) Strut shoe spring              |                                 |
| (12) Inner pad        | (25) Shoe guide plate               |                                 |
| (13) Outer pad        | (26) Secondary shoe return spring   |                                 |

**Tightening torque: N-m (kg-m, ft-lb)**  
**T1: 8±1 (0.8±0.1, 5.8±0.7)**  
**T2: 39±5 (4.0±0.5, 28.9±3.6)**  
**T3: 52<sup>+10</sup>/<sub>-6</sub> (5.3<sup>+1.0</sup>/<sub>-0.6</sub>, 38.2<sup>+7.2</sup>/<sub>-4.3</sub>)**

## 3. Rear Drum Brake

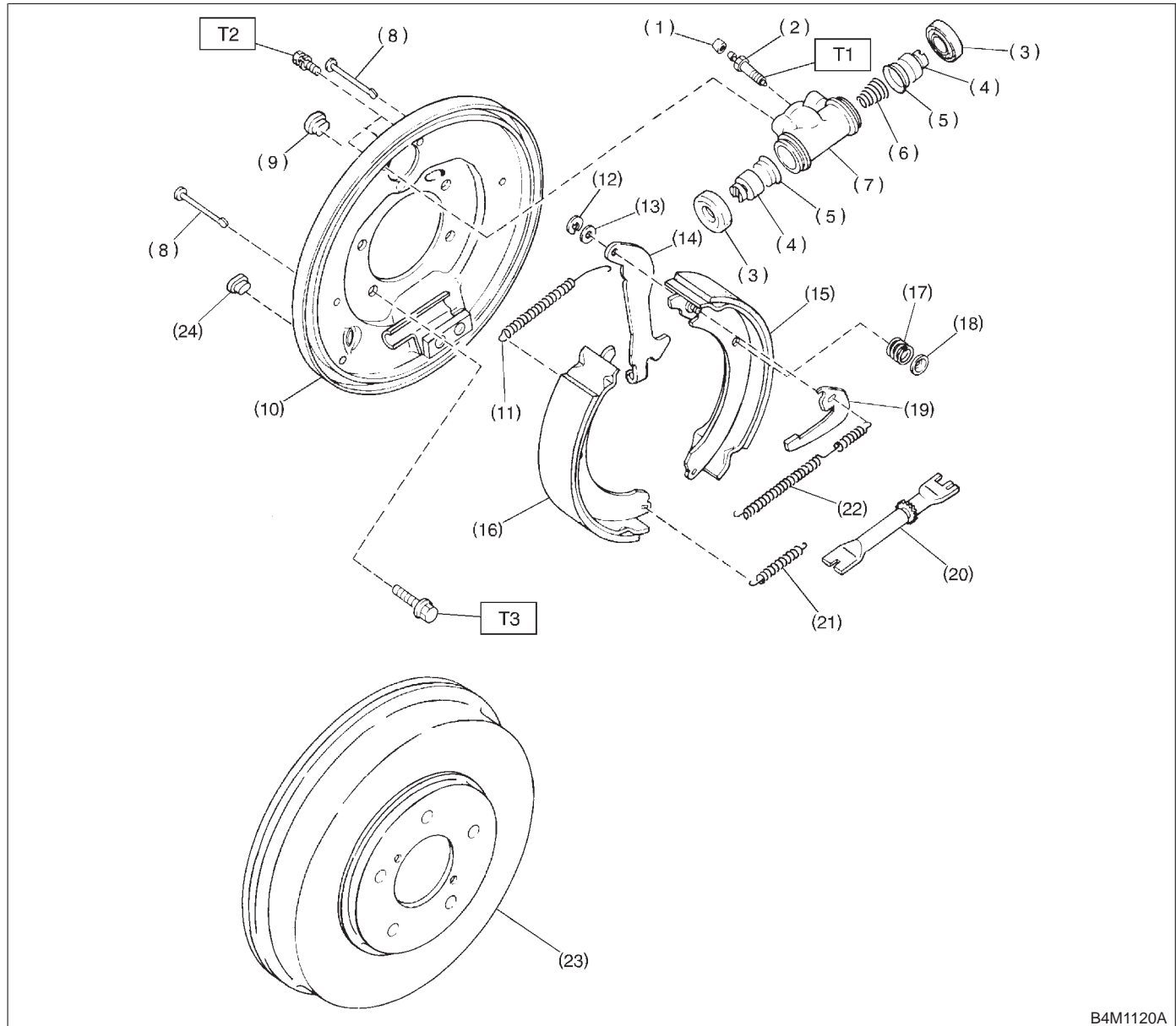

B4M1120A

- |                         |                               |                               |
|-------------------------|-------------------------------|-------------------------------|
| (1) Air bleeder cap     | (11) Upper shoe return spring | (21) Lower shoe return spring |
| (2) Air bleeder screw   | (12) Retainer                 | (22) Adjusting spring         |
| (3) Boot                | (13) Washer                   | (23) Drum                     |
| (4) Piston              | (14) Parking brake lever      | (24) Plug                     |
| (5) Cup                 | (15) Brake shoe (Trailing)    |                               |
| (6) Spring              | (16) Brake shoe (Leading)     |                               |
| (7) Wheel cylinder body | (17) Shoe hold-down spring    |                               |
| (8) Pin                 | (18) Cup                      |                               |
| (9) Plug                | (19) Adjusting lever          |                               |
| (10) Back plate         | (20) Adjuster                 |                               |

**Tightening torque: N-m (kg-m, ft-lb)****T1: 8±1 (0.8±0.1, 5.8±0.7)****T2: 10±2 (1.0±0.2, 7.2±1.4)****T3: 52±6 (5.3±0.6, 38.3±4.3)**

## 4. Master Cylinder

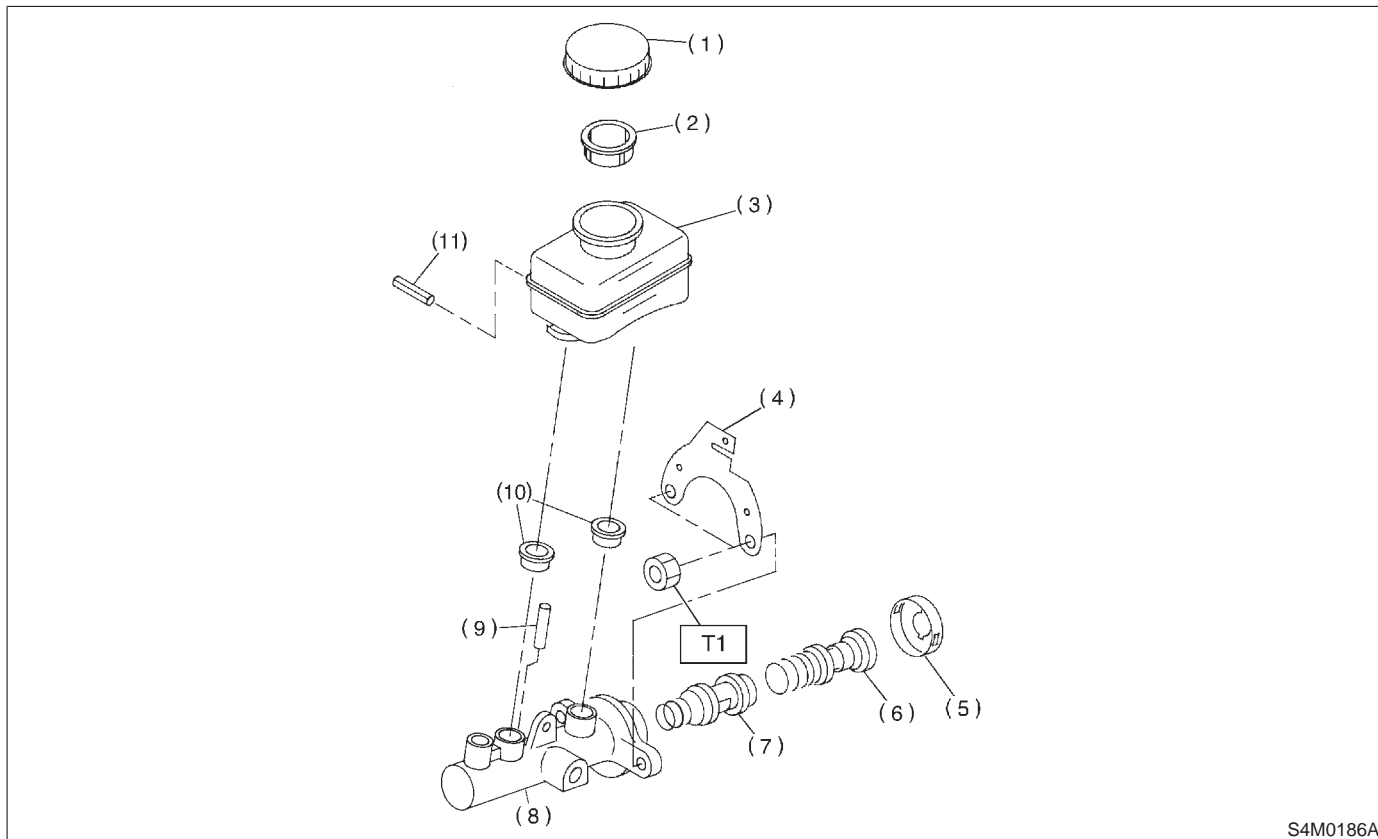

S4M0186A

- (1) Cap
- (2) Filter
- (3) Reservoir tank
- (4) Bracket
- (5) Piston retainer

- (6) Primary piston
- (7) Secondary piston
- (8) Cylinder body
- (9) Cylinder pin
- (10) Seal

- (11) Pin

**Tightening torque: N·m (kg·m, ft·lb)**

**T1: 14±4 (1.4±0.4, 10.1±2.9)**

5. Brake Booster

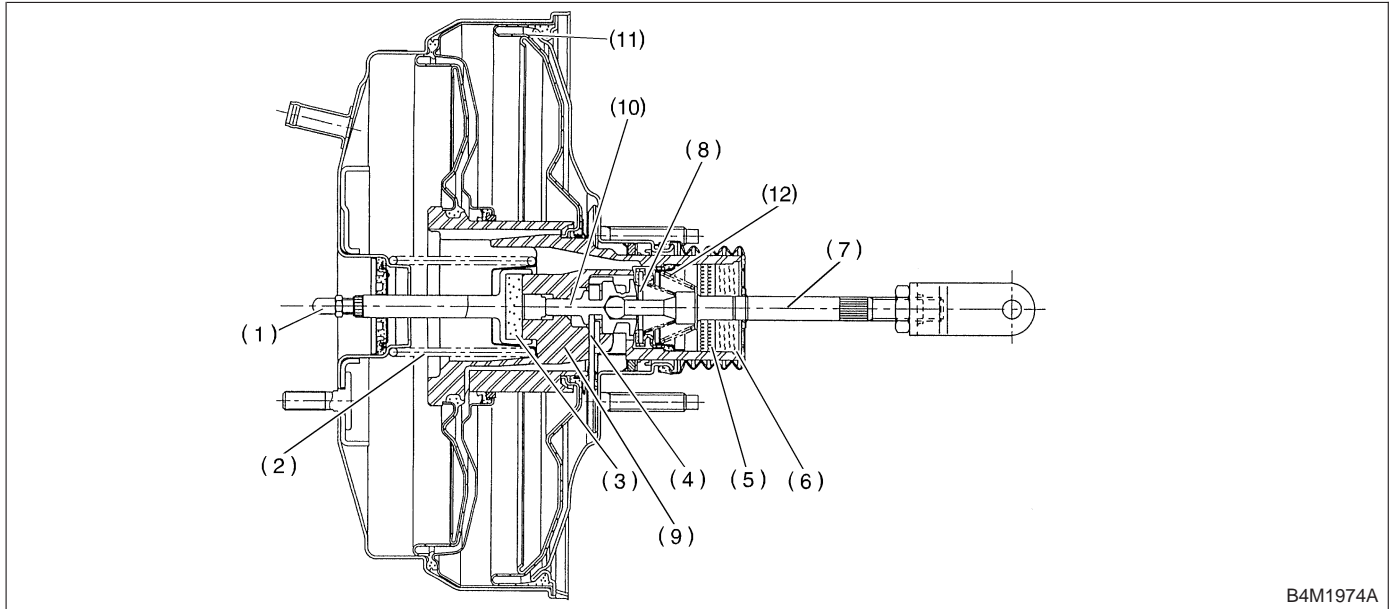

B4M1974A

- |                   |                   |                          |
|-------------------|-------------------|--------------------------|
| (1) Push rod      | (5) Filter        | (9) Valve body           |
| (2) Return spring | (6) Silencer      | (10) Plunger valve       |
| (3) Reaction disc | (7) Operating rod | (11) Diaphragm plate     |
| (4) Key           | (8) Poppet valve  | (12) Valve return spring |

6. ABS System

A: SENSOR

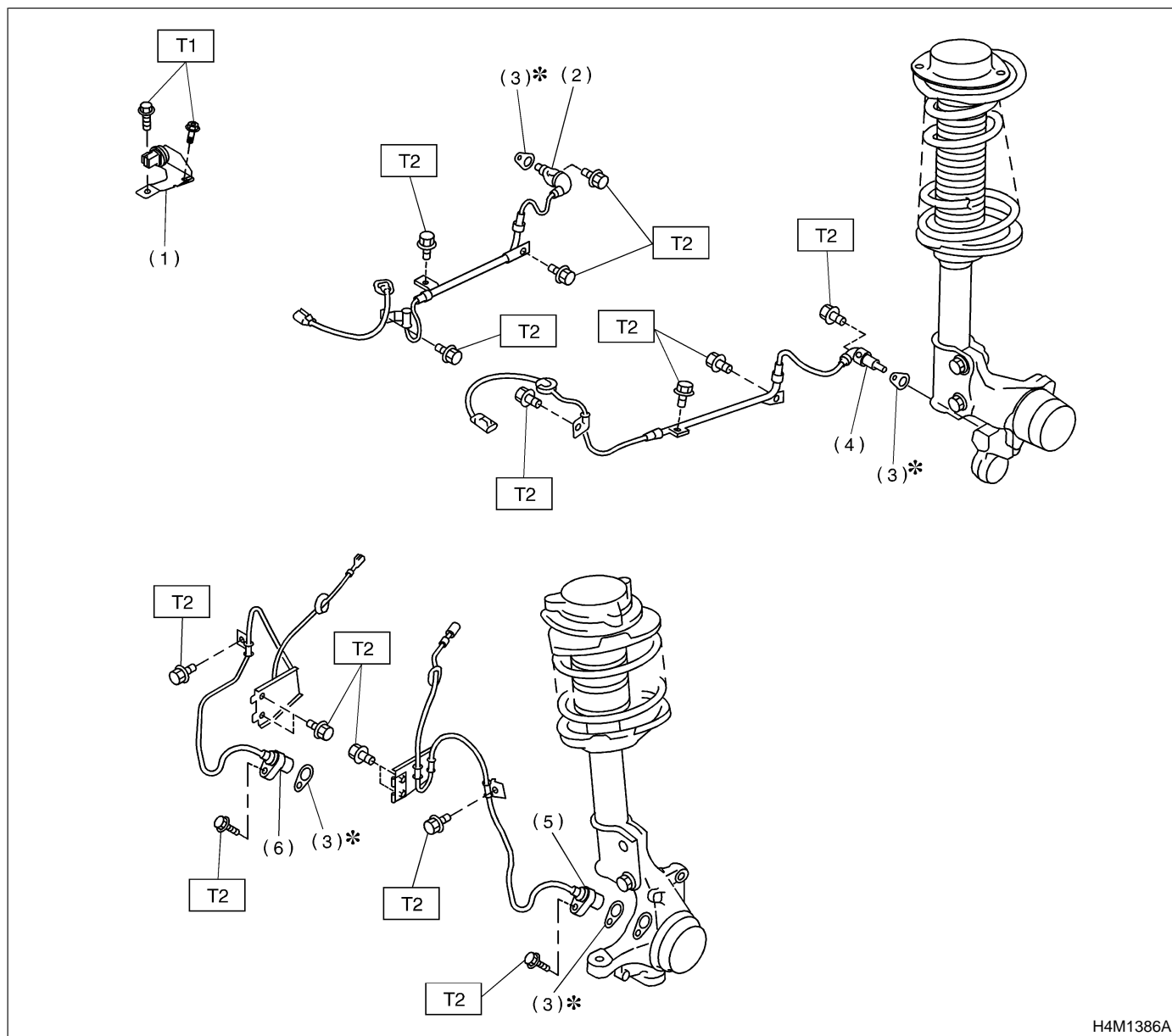

- (1) G sensor
- (2) Rear ABS sensor RH
- (3) ABS spacer
- (4) Rear ABS sensor LH
- (5) Front ABS sensor LH
- (6) Front ABS sensor RH

**Tightening torque: N·m (kg·m, ft·lb)**  
**T1: 7.4±2.0 (0.75±0.2, 5.4±1.4)**  
**T2: 32±10 (3.3±1.0, 24±7)**



**B: ABS CONTROL MODULE AND HYDRAULIC CONTROL UNIT (ABSCM&H/U)**

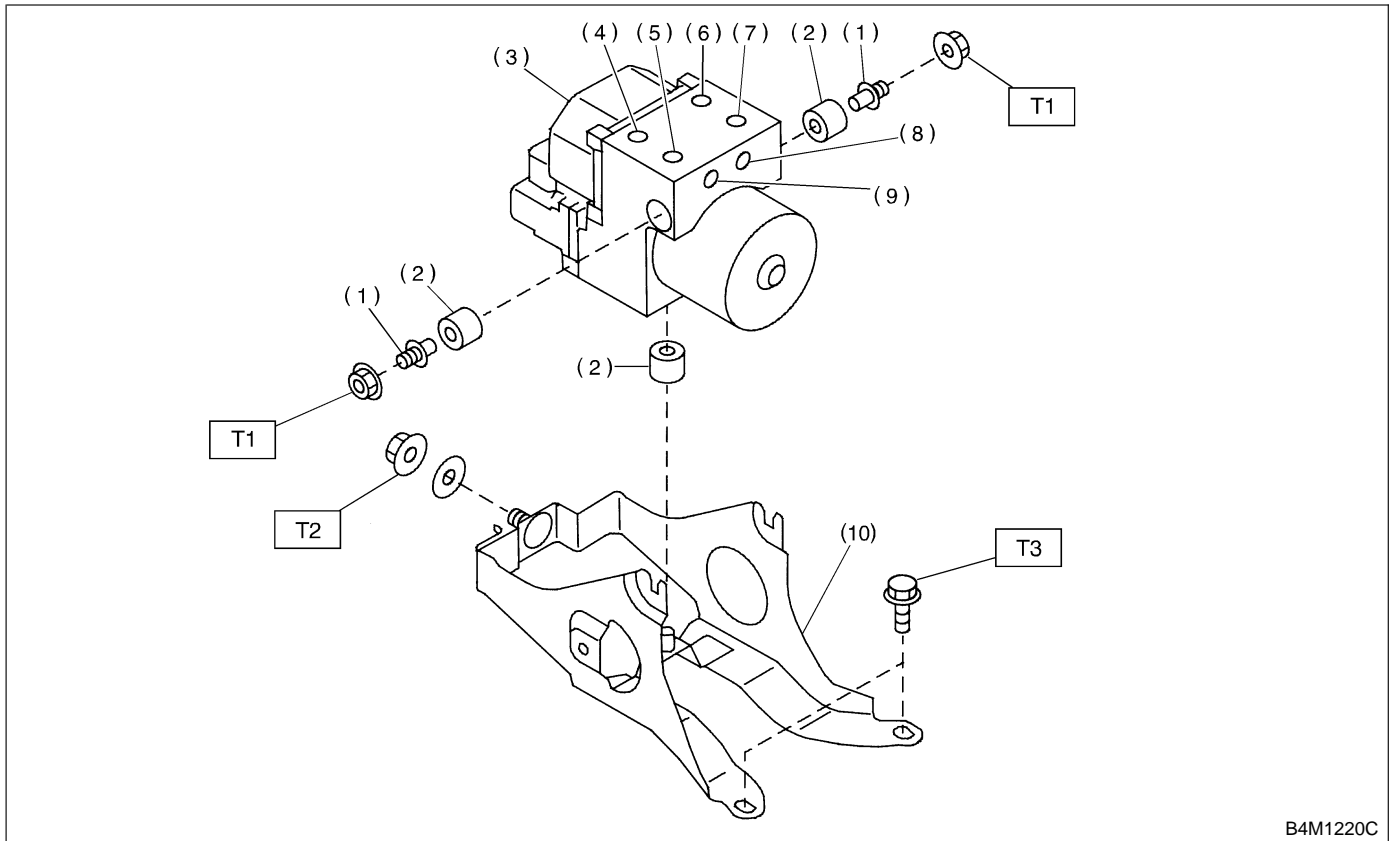

- (1) Stud bolt
- (2) Damper
- (3) ABS control module and hydraulic control unit
- (4) Front-LH outlet
- (5) Secondary inlet

- (6) Front-RH outlet
- (7) Primary inlet
- (8) Rear-LH outlet
- (9) Rear-RH outlet
- (10) Bracket

**Tightening torque: N·m (kg·m, ft·lb)**

**T1: 18±5 (1.8±0.5, 13.0±3.6)**

**T2: 29±7 (3.0±0.7, 21.7±5.1)**

**T3: 32±10 (3.3±1.0, 24±7)**

7. Parking Brake

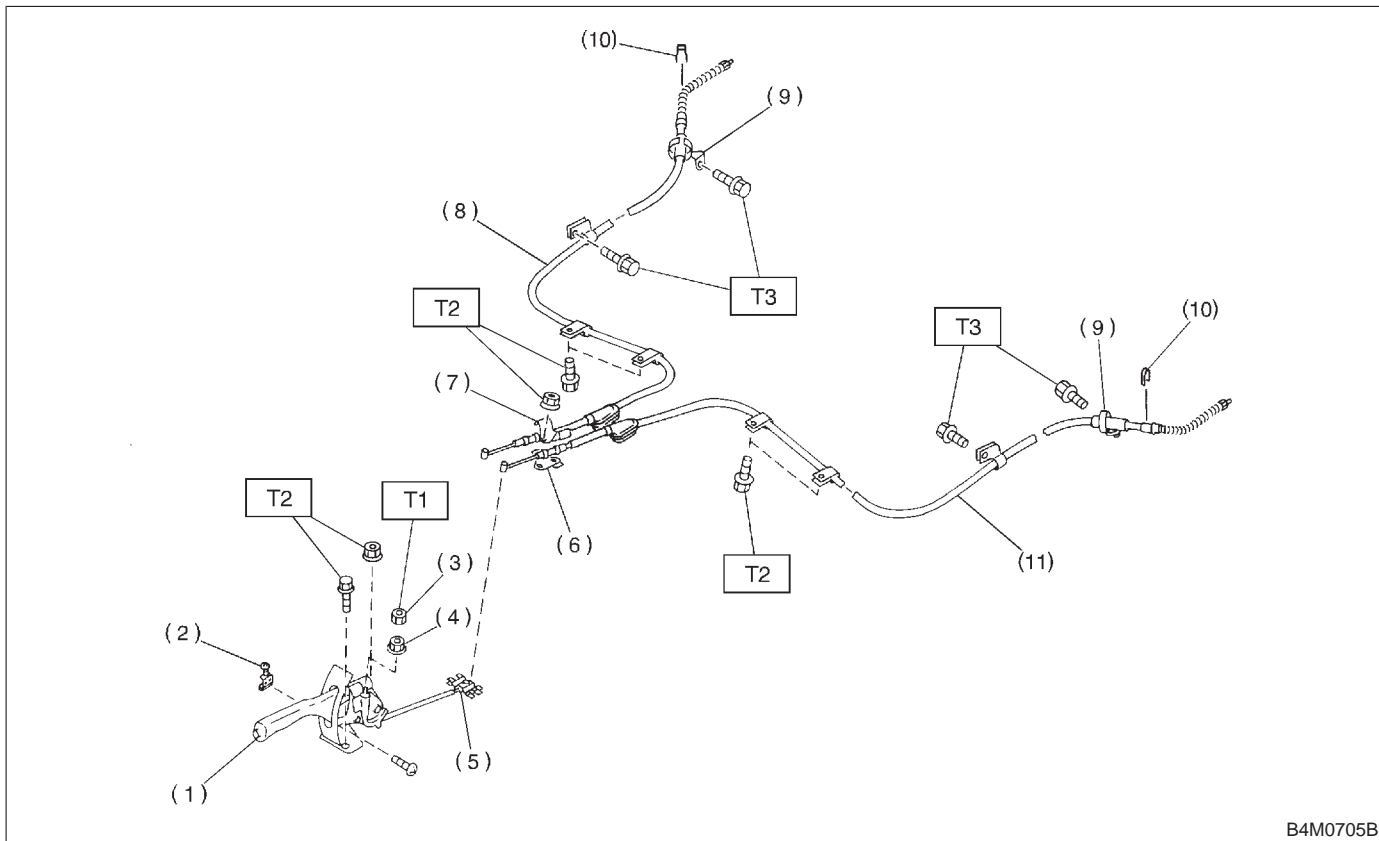

B4M0705B

- |                          |   |
|--------------------------|---|
| (1) Parking brake lever  | (7) Clamp                               |
| (2) Parking brake switch | (8) Parking brake cable RH              |
| (3) Lock nut             | (9) Cable guide                         |
| (4) Adjusting nut        | (10) Clamp (Rear disc brake model only) |
| (5) Equalizer            | (11) Parking brake cable LH             |
| (6) Bracket              |   |

**Tightening torque: N-m (kg-m, ft-lb)**  
**T1: 5.9±1.5 (0.60±0.15, 4.3±1.1)**  
**T2: 18±5 (1.8±0.5, 13.0±3.6)**  
**T3: 32±10 (3.3±1.0, 24±7)**

# 1. Front Disc Brake

## A: ON-CAR SERVICE

### 1. PAD

- 1) Remove lock pin.
- 2) Raise caliper body.
- 3) Remove pad.

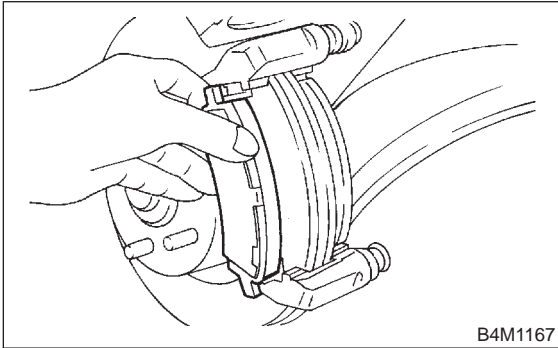

**NOTE:**

If brake pad is difficult to remove, proceed as follows:

- (1) Remove caliper body and fasten it provisionally to coil spring.
- (2) Remove support.
- (3) Place a support in a vise between wooden blocks.

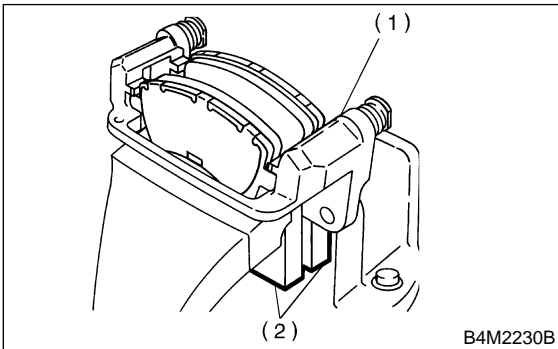

- (1) Support
- (2) Wooden blocks

- (4) Attach a rod of less than 12 mm (0.47 in) dia. to the shaded area of brake pad, and strike the rod with a hammer to drive brake pad out of place.

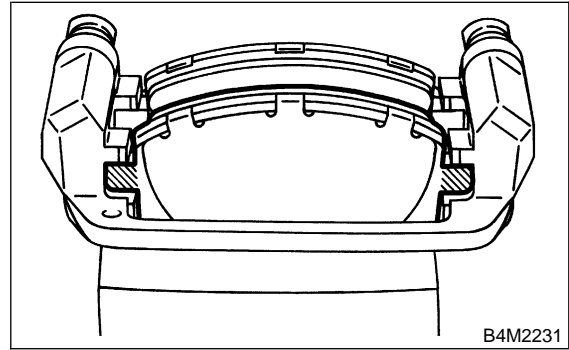

- 4) Check pad thickness A.

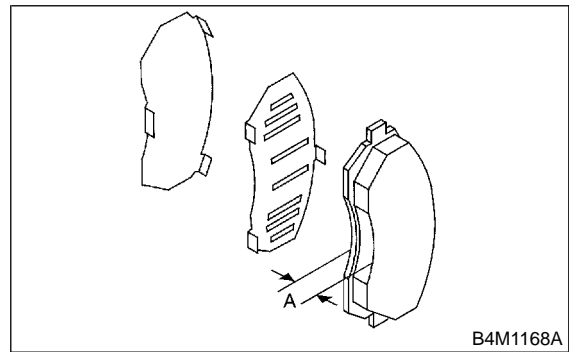

Pad thickness (including back metal)	Standard value	17 mm (0.67 in)
	Wear limit	7.5 mm (0.295 in)

**CAUTION:**

- Always replace the pads for both the left and right wheels at the same time. Also replace pad clips if they are twisted or worn.
- A wear indicator is provided on the inner disc brake pad. If the pad wears down to such an extent that the end of the wear indicator contacts the disc rotor, a squeaking sound is produced as the wheel rotates. If this sound is heard, replace the pad.
- Replace pad if there is oil or grease on it.

5) Apply a thin coat of Molykote AS880N (Part No. 26298AC000) to the frictional portion between pad and pad clip.

6) Apply a thin coat of Molykote AS880N (Part No. 26298AC000) to the frictional portion between pad and inner shim.

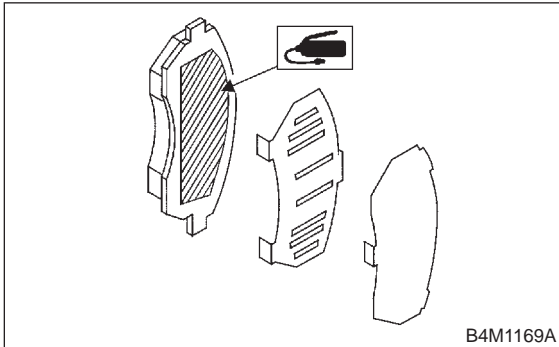

7) Install pads on support.

8) Install caliper body on support.

**NOTE:**

If it is difficult to push piston during pad replacement, loosen air bleeder to facilitate work.

## 2. DISC ROTOR

1) Install disc rotor by tightening the five wheel nuts.

2) Set a dial gauge on the disc rotor. Turn disc rotor to check runout.

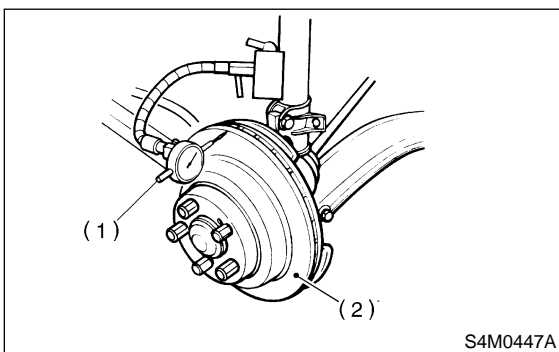

- (1) Dial gauge
- (2) Disc rotor

**NOTE:**

Make sure that dial gauge is set 5 mm (0.20 in) inward of rotor outer perimeter.

**Disc rotor runout limit:**  
**0.075 mm (0.0030 in)**

3) Measure disc rotor thickness.

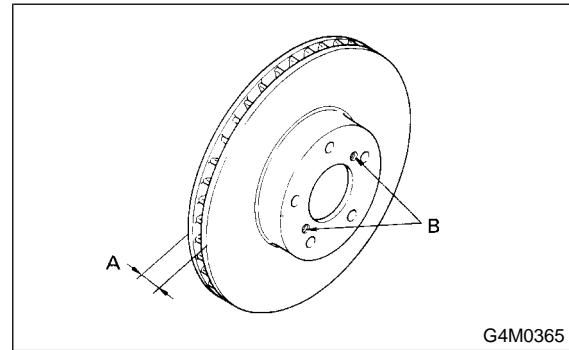

**NOTE:**

Make sure that micrometer is set 5 mm (0.20 in) inward of rotor outer perimeter.

Disc rotor thickness A	Standard value	Service limit	Disc outer dia.
	24 mm (0.94 in)	22 mm (0.87 in)	260 mm (10.24 in)

**B: REMOVAL**

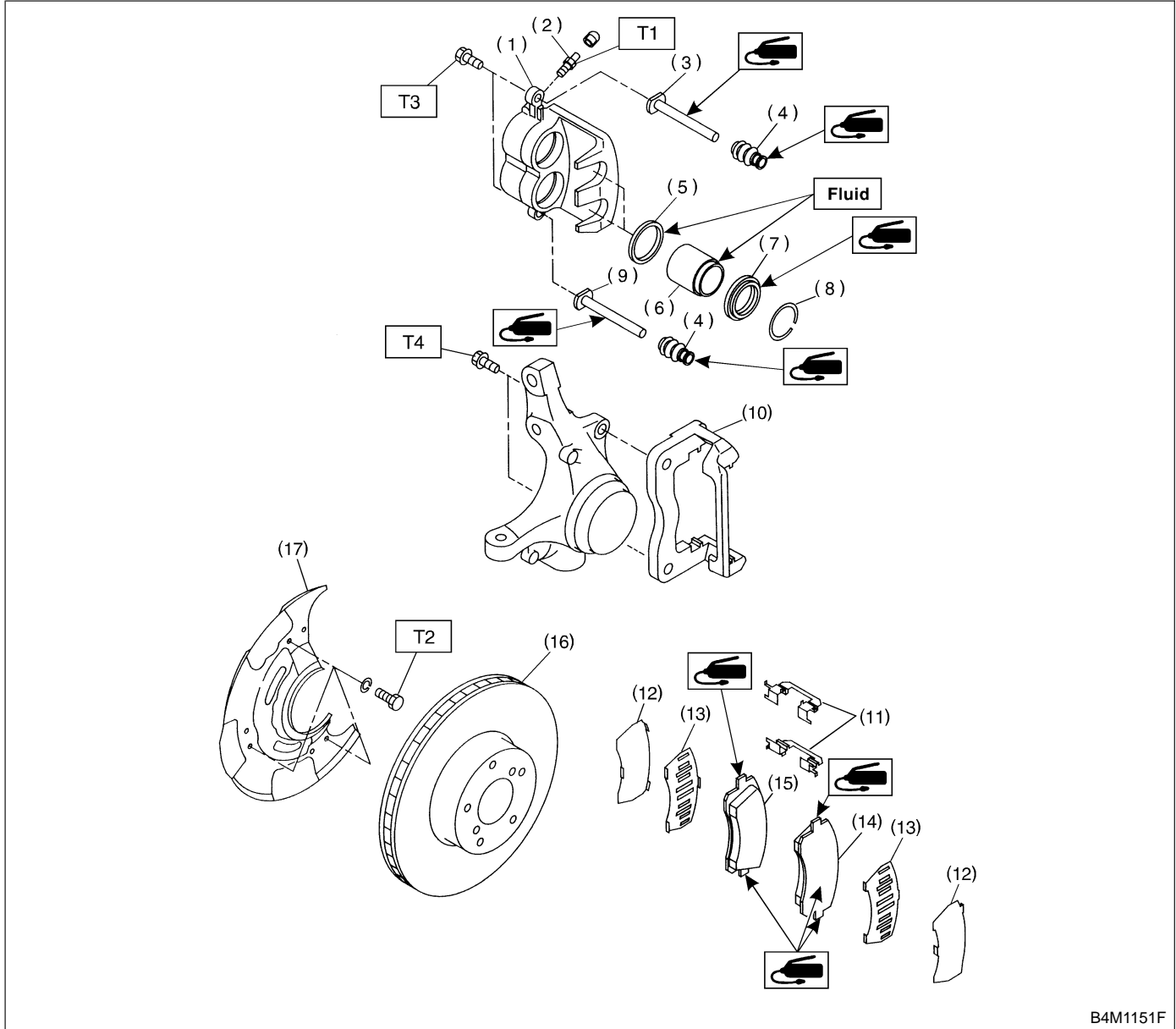

B4M1151F

- (1) Caliper body
- (2) Air bleeder screw
- (3) Guide pin (Green)
- (4) Pin boot
- (5) Piston seal
- (6) Piston
- (7) Piston boot
- (8) Boot ring

- (9) Lock pin (Yellow)
- (10) Support
- (11) Pad clip
- (12) Outer shim
- (13) Inner shim
- (14) Pad (Outside)
- (15) Pad (Inside)
- (16) Disc rotor

- (17) Disc cover

**Tightening torque: N-m (kg-m, ft-lb)**

**T1: 8±1 (0.8±0.1, 5.8±0.7)**

**T2: 18±5 (1.8±0.5, 13.0±3.6)**

**T3: 37±5 (3.8±0.5, 27.5±3.6)**

**T4: 78±10 (8.0±1.0, 58±7)**

- 1) Remove union bolt and disconnect brake hose from caliper body assembly.

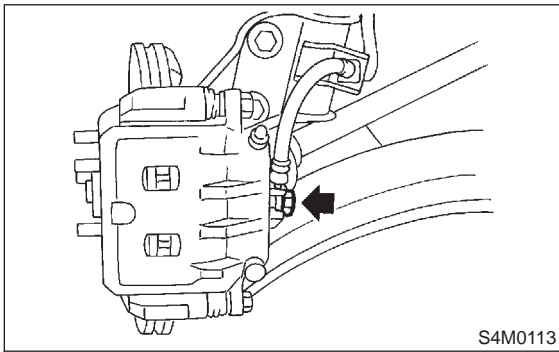

- 2) Remove bolt securing lock pin to caliper body.

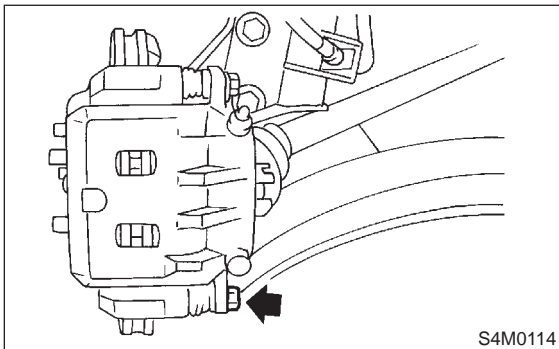

- 3) Raise caliper body and move it toward vehicle center to separate it from support.
- 4) Remove support from housing.

**NOTE:**  
Remove support only when replacing it or the rotor. It need not be removed when servicing caliper body assembly.

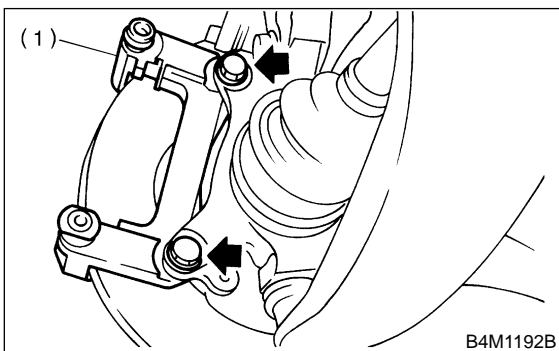

- (1) Support

- 5) Remove disc rotor from hub.

**NOTE:**  
If disc rotor seizes up within hub, drive disc rotor out by installing an 8-mm bolt in holes B on the rotor.

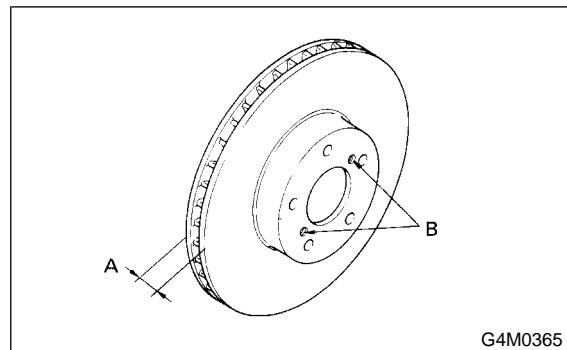

- 6) Clean mud and foreign particles from caliper body assembly and support.

## C: DISASSEMBLY

- 1) Clean mud and foreign particles from caliper body assembly and support.

**CAUTION:**  
**Be careful not to allow foreign particles to enter inlet (at brake hose connector).**

- 2) Using a standard screwdriver, remove boot ring from piston.

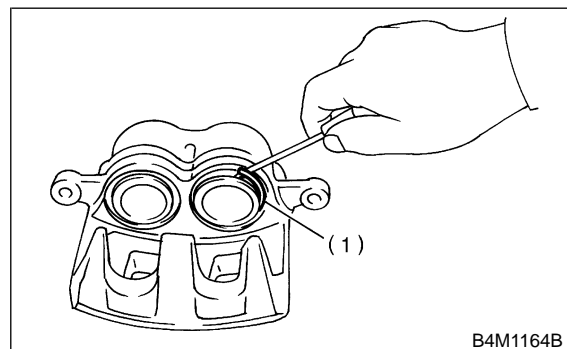

- (1) Boot ring

- 3) Remove boot from piston end.

4) Gradually supply compressed air via caliper body brake hose to force piston out.

**CAUTION:**

Place a wooden block as shown in Figure to prevent damage to piston.

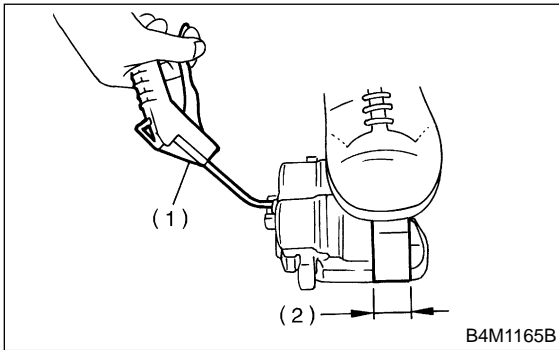

- (1) Air gun
- (2) Place a 30 mm (1.18 in) wide wooden block here.

5) Remove piston seal from caliper body cylinder.

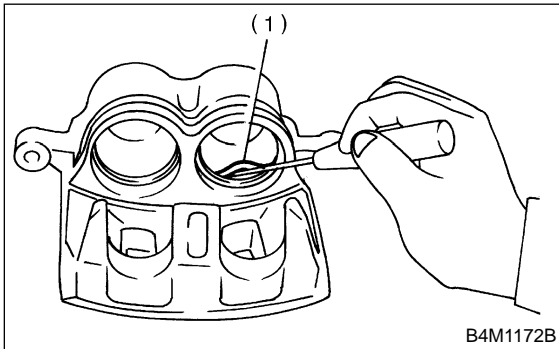

- (1) Piston seal

6) Remove lock pin boot and guide pin boot.

**D: INSPECTION**

- 1) Repair or replace faulty parts.
- 2) Check caliper body and piston for uneven wear, damage or rust.
- 3) Check rubber parts for damage or deterioration.

**E: ASSEMBLY**

- 1) Clean caliper body interior using brake fluid.
- 2) Apply a coat of brake fluid to piston seal and fit piston seal in groove on caliper body.
- 3) Apply a coat of brake fluid to the entire inner surface of cylinder and outer surface of piston.
- 4) Insert piston into cylinder.

**CAUTION:**

Do not force piston into cylinder.

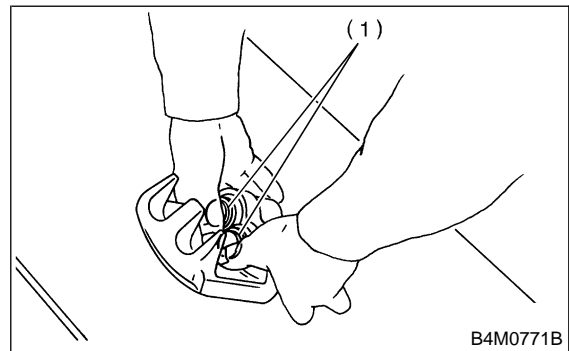

- (1) Piston

5) Apply a coat of specified grease to boot and fit in groove on ends of cylinder and piston.

**Grease:**

**NIGLUBE RX-2 (Part No. 003606000)**

To facilitate installation, fit boot starting with piston end.

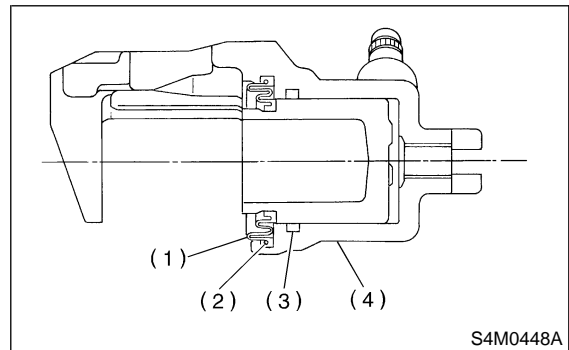

- (1) Piston boot
- (2) Boot ring
- (3) Piston seal
- (4) Caliper body

- 6) Position boot in grooves on cylinder and piston.
- 7) Install boot ring. Be careful not scratch boot.

8) Apply a coat of specified grease to lock pin and guide pin, outer surface, cylinder inner surface, and boot grooves.

**Grease:**

**NIGLUBE RX-2 (Part No. 003606000)**

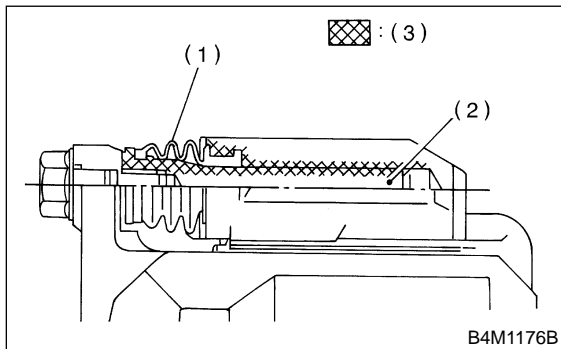

- (1) Pin boot
- (2) Lock pin or guide pin
- (3) Apply grease.

9) Install lock pin boot and guide pin boot on support.

**F: INSTALLATION**

- 1) Install disc rotor on hub.
- 2) Install support on housing.

**Tightening torque:**

**$78 \pm 10 \text{ N}\cdot\text{m}$  ( $8 \pm 1 \text{ kg}\cdot\text{m}$ ,  $58 \pm 7 \text{ ft}\cdot\text{lb}$ )**

**CAUTION:**

- Always replace the pads for both the left and right wheels at the same time. Also replace pad clips if they are twisted or worn.
- A wear indicator is provided on the inner disc brake pad. If the pad wears down to such an extent that the end of the wear indicator contacts the disc rotor, a squeaking sound is produced as the wheel rotates. If this sound is heard, replace the pad.
- When replacing the pad, replace pads of the right and left wheels at the same time.

3) Apply a thin coat of Molykote AS880N (Part No. 26298AC000) to the frictional portion between pad and pad clip.

4) Apply a thin coat of Molykote AS880N (Part No. 26298AC000) to the frictional portion between pad and inner shim.

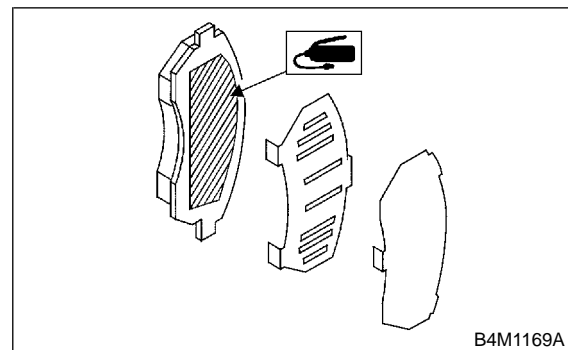

- 5) Install pads, rubber coated shim and stainless shim on support.
- 6) Install caliper body on support.

**Tightening torque:**

**$39 \pm 5 \text{ N}\cdot\text{m}$  ( $4 \pm 0.5 \text{ kg}\cdot\text{m}$ ,  $28.9 \pm 3.6 \text{ ft}\cdot\text{lb}$ )**

7) Connect brake hose.

**Tightening torque:**

**$18 \pm 3 \text{ N}\cdot\text{m}$  ( $1.8 \pm 0.3 \text{ kg}\cdot\text{m}$ ,  $13.0 \pm 2.2 \text{ ft}\cdot\text{lb}$ )**

**CAUTION:**

**Replace brake hose gaskets with new ones.**

8) Bleed air from brake system.



## 2. Rear Disc Brake

### A: ON-CAR SERVICE

#### 1. PAD

- 1) Remove lock pin.

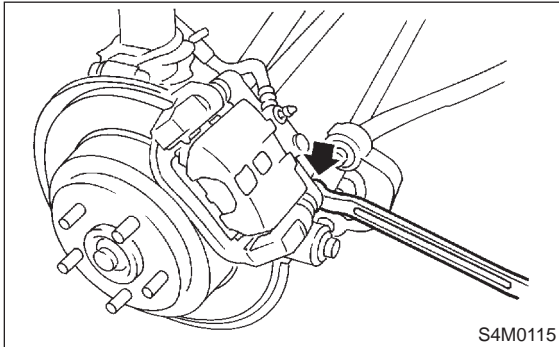

- 2) Raise caliper body.
- 3) Remove pad from support.

**NOTE:**

If brake pad is difficult to remove, use the same procedure as for front disc brake pad. <Ref. to 4-4 [W1A1].>

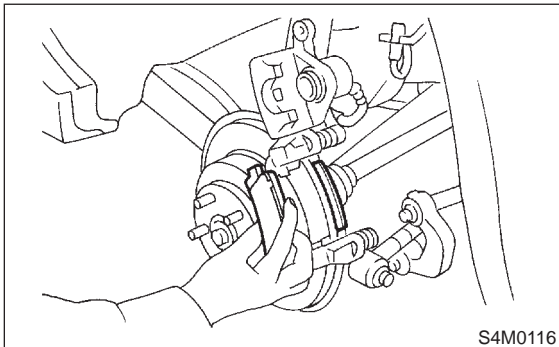

- 4) Check pad thickness (including back metal).

**Pad thickness: A**

**Standard value**

**14 mm (0.55 in)**

**Wear limit**

**6.5 mm (0.256 in)**

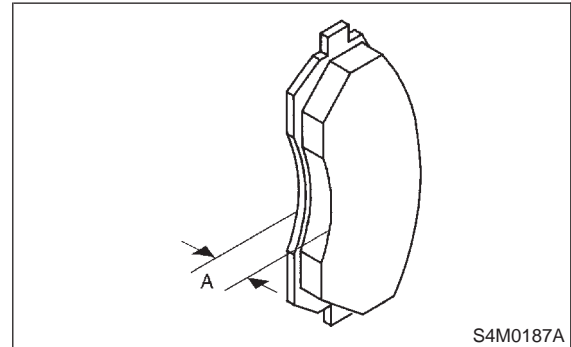

**CAUTION:**

- Always replace the pads for both the left and right wheels at the same time. Also replace pad clips if they are twisted or worn.
- A wear indicator is provided on the inner disc brake pad. If the pad wears down to such an extent that the end of the wear indicator contacts the disc rotor, a squeaking sound is produced as the wheel rotates. If this sound is heard, replace the pad.
- Replace pad if there is oil or grease on it.

- 5) Apply a thin coat of Molykote AS880N (Part No. 26298AC000) to the frictional portion between pad and pad clip.
- 6) Install pad on support.
- 7) Install caliper body on support.

**Tightening torque:**

**39±5 N-m (4.0±0.5 kg-m, 28.9±3.6 ft-lb)**

**NOTE:**

If it is difficult to push piston during pad replacement, loosen air bleeder to facilitate work.

## 2. DISC ROTOR

- 1) Install disc rotor by tightening the five wheel nuts.
- 2) Set a dial gauge on the disc rotor. Turn disc rotor to check runout.

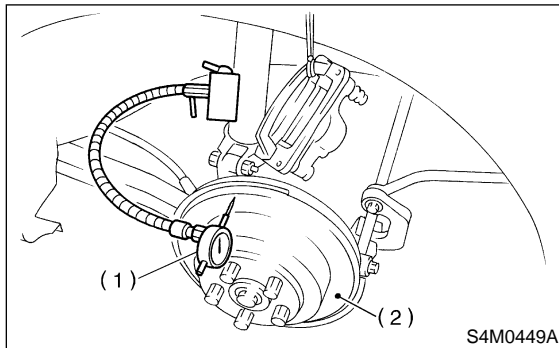

- (1) Disc rotor
- (2) Dial gauge

**NOTE:**

Make sure that dial gauge is set 5 mm (0.20 in) inward of rotor outer perimeter.

**Disc rotor runout limit:**  
**0.07 mm (0.0028 in)**

- 3) Measure disc rotor thickness.

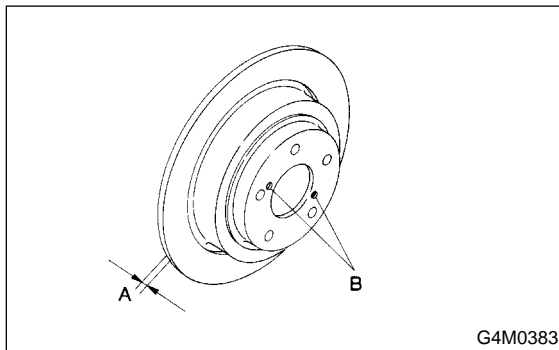

**NOTE:**

Make sure that micrometer is set 5 mm (0.20 in) inward of rotor outer perimeter.

**Disc rotor thickness: A**  
**Standard value**  
**10 mm (0.39 in)**  
**Service limit**  
**8.5 mm (0.335 in)**

**NOTE:**

When removing disc rotor, refer to instructions under Parking Brake. <Ref. to 4-4 [W4A0].>

**B: REMOVAL**

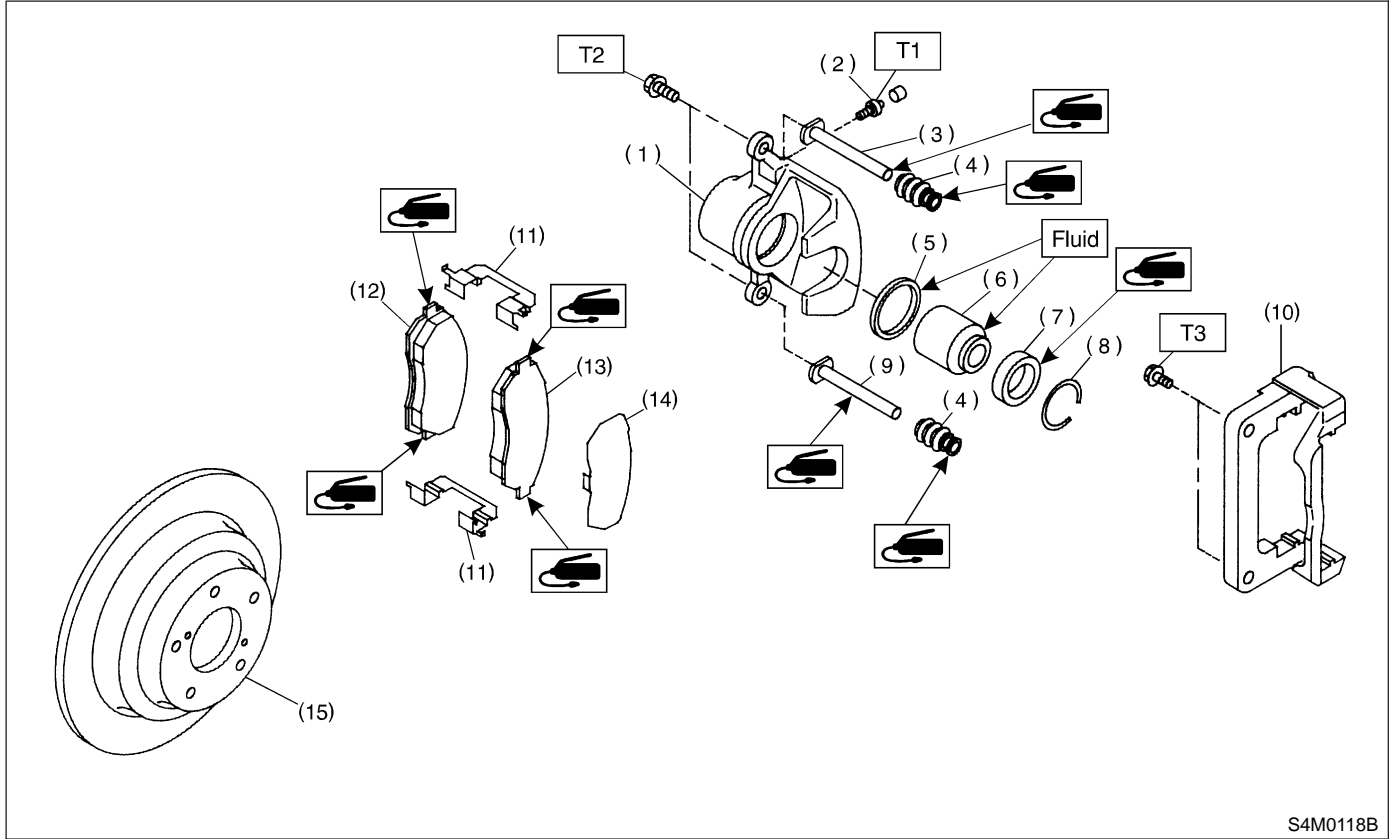

S4M0118B

- |                       |                       |
|-----------------------|-----------------------|
| (1) Caliper body      | (9) Lock pin (Yellow) |
| (2) Air bleeder screw | (10) Support          |
| (3) Guide pin (Green) | (11) Pad clip         |
| (4) Pin boot          | (12) Inner pad        |
| (5) Piston seal       | (13) Outer pad        |
| (6) Piston            | (14) Shim             |
| (7) Piston boot       | (15) Disc rotor       |
| (8) Boot ring         |                       |

**Tightening torque: N-m (kg-m, ft-lb)**

**T1: 8±1 (0.8±0.1, 5.8±0.7)**

**T2: 39±5 (4.0±0.5, 28.9±3.6)**

**T3: 52<sup>+10</sup>/<sub>-6</sub> (5.3<sup>+1.0</sup>/<sub>-0.6</sub>, 38.2<sup>+7.2</sup>/<sub>-4.3</sub>)**

- 1) Lift-up vehicle and remove wheels.
- 2) Disconnect brake hose from caliper body assembly.

**CAUTION:**

**Do not allow brake fluid to come in contact with vehicle body; wipe off completely if spilled.**

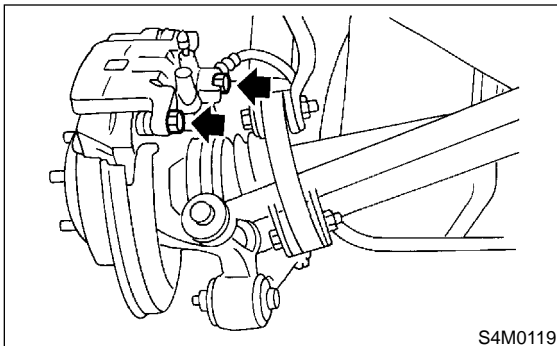

S4M0119

- 3) Remove lock pin.

- 4) Raise caliper body and move it toward vehicle center to separate it from support.
- 5) Remove support from back plate.

**NOTE:**

Remove support only when replacing it or the rotor. It need not be removed when servicing caliper body assembly.

- 6) Clean mud and foreign particles from caliper body assembly and support.

**CAUTION:**

**Be careful not to allow foreign particles to enter inlet (at brake hose connector).**

**C: DISASSEMBLY**

1) Remove the boot ring.

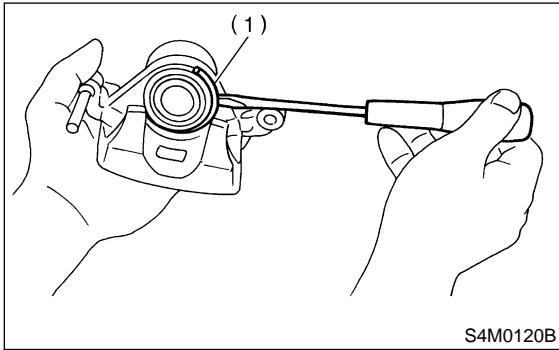

(1) Boot ring

2) Remove the piston boot.

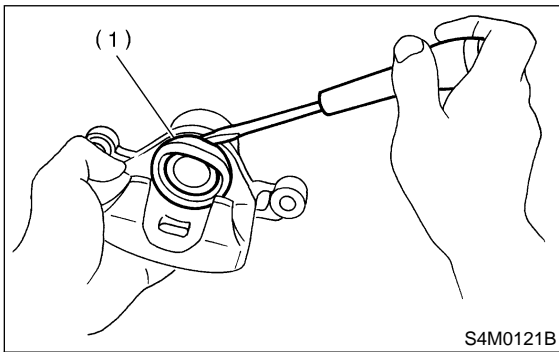

(1) Piston boot

3) Gradually supply compressed air via inlet of caliper body to force piston out.

**CAUTION:**

- Place a wooden block as shown in Figure to prevent damage to piston.
- Do not apply excessively high-pressure.

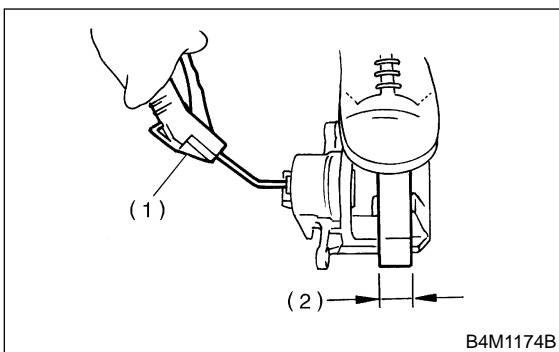

(1) Air gun  
(2) Place a 30 mm (1.18 in) wide wooden block here.

4) Remove piston seal from caliper body cylinder.

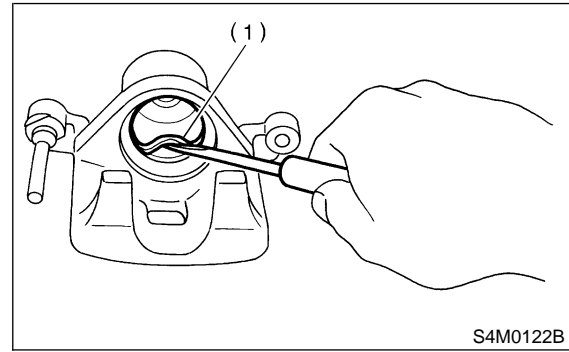

(1) Piston seal

5) Remove lock pin sleeve and boot from caliper body.

6) Remove guide pin boot.

**D: INSPECTION**

- 1) Repair or replace faulty parts.
- 2) Check caliper body and piston for uneven wear, damage or rust.
- 3) Check rubber parts for damage or deterioration.

**E: ASSEMBLY**

- 1) Clean caliper body interior using brake fluid.
- 2) Apply a coat of brake fluid to piston seal and fit piston seal in groove on caliper body.
- 3) Apply a coat of brake fluid to the entire inner surface of cylinder and outer surface of piston.
- 4) Insert piston into cylinder.

**CAUTION:**

**Do not force piston into cylinder.**

- 5) Apply a coat of specified grease to boot and fit in groove on ends of cylinder and piston.

**Grease**

**NIGLUBE RX-2 (Part No. 003606000)**

## 2. Rear Disc Brake

- 6) Install the piston boot to the caliper body, and attach boot ring.

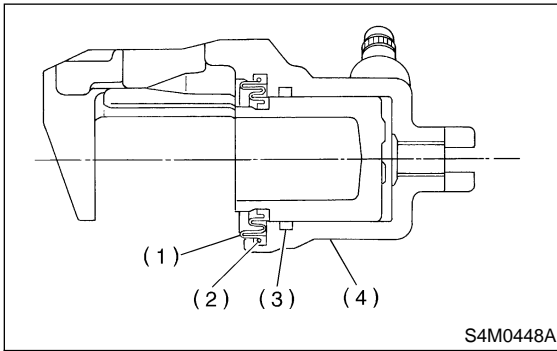

- (1) Piston boot  
 (2) Boot ring  
 (3) Piston seal  
 (4) Caliper body

- 7) Apply a coat of specified grease to guide pin, outer surface, sleeve outer surface, cylinder inner surface, and boot grooves.

**Grease**

**NIGLUBE RX-2 (Part No. 003606000)**

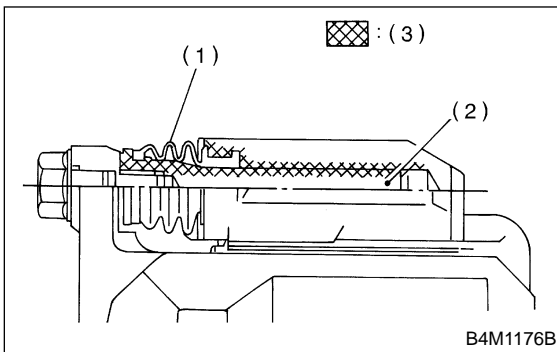

- (1) Pin boot  
 (2) Lock pin or guide pin  
 (3) Apply grease.

- 8) Install guide pin boot on caliper body.  
 9) Install lock pin boot on caliper body and insert lock pin sleeve into place.

**F: INSTALLATION**

- 1) Install disc rotor on hub.
- 2) Install support on back plate.

**Tightening torque:**

$52^{+10}_{-6}$  N·m ( $5.3^{+1.0}_{-0.6}$  kg·m,  $38.2^{+7.2}_{-4.3}$  ft·lb)

**CAUTION:**

- Always replace the pads for both the left and right wheels at the same time. Also replace pad clips if they are twisted or worn.
- A wear indicator is provided on the inner disc brake pad. If the pad wears down to such an extent that the end of the wear indicator contacts the disc rotor, a squeaking sound is produced as the wheel rotates. If this sound is heard, replace the pad.
- Replace pads if there is oil or grease on them.

- 3) Apply a thin coat of Molykote AS880N (Part No. 26298AC000) to the frictional portion between pad and pad clip.
- 4) Install pads on support.
- 5) Install caliper body on support.

**Tightening torque:**

$39\pm 5$  N·m ( $4.0\pm 0.5$  kg·m,  $28.9\pm 3.6$  ft·lb)

- 6) Connect brake hose.

**Tightening torque:**

$18\pm 3$  N·m ( $1.8\pm 0.3$  kg·m,  $13.0\pm 2.2$  ft·lb)

**CAUTION:**

- The brake hose must be connected without any twist.
  - Replace brake hose gaskets with new ones.
- 7) Bleed air from brake system.

### 3. Rear Drum Brake

#### A: REMOVAL

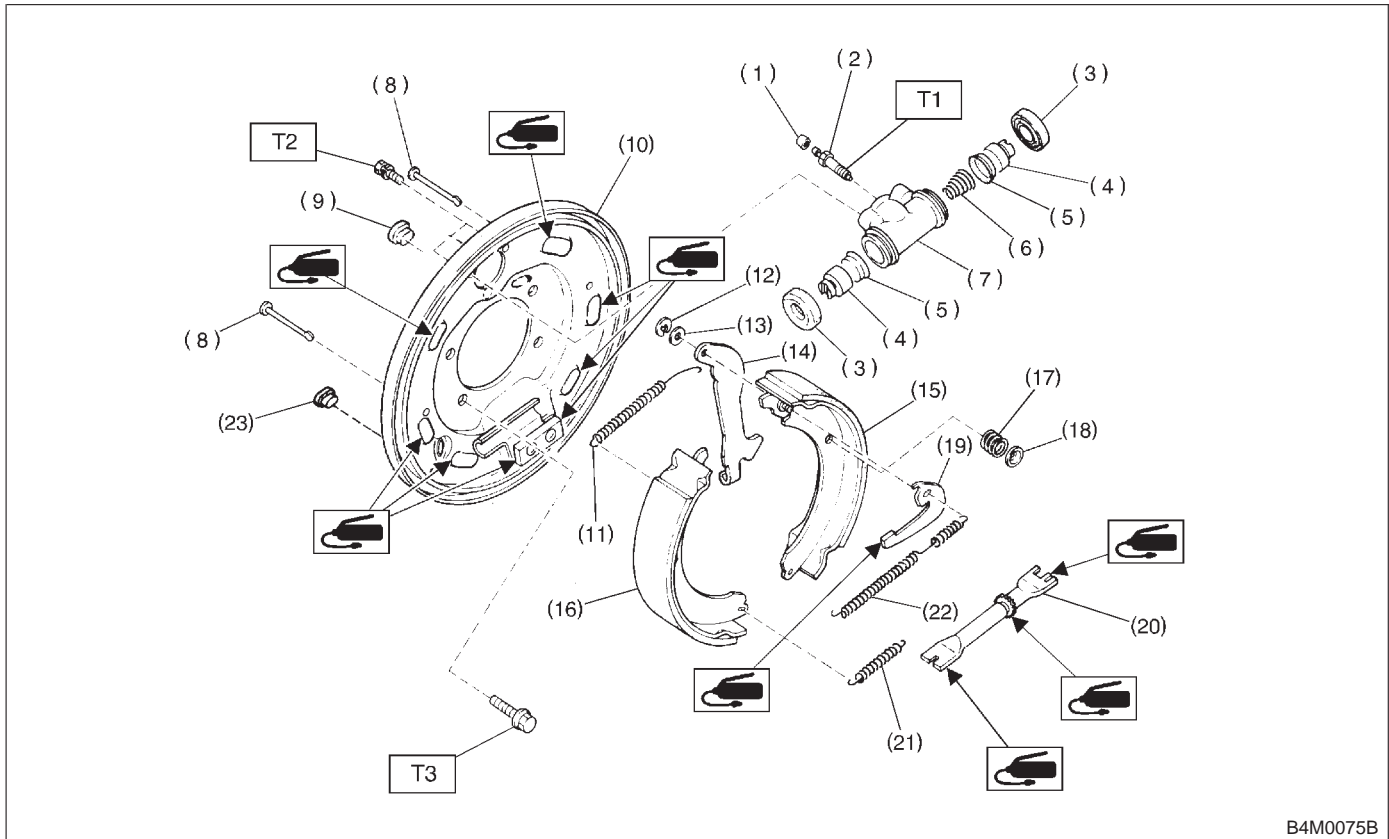

B4M0075B

- |                         |                               |                               |
|-------------------------|-------------------------------|-------------------------------|
| (1) Air bleeder cap     | (11) Upper shoe return spring | (21) Lower shoe return spring |
| (2) Air bleeder screw   | (12) Retainer                 | (22) Adjusting spring         |
| (3) Boot                | (13) Washer                   | (23) Plug                     |
| (4) Piston              | (14) Parking brake lever      |                               |
| (5) Cup                 | (15) Brake shoe (Trailing)    |                               |
| (6) Spring              | (16) Brake shoe (Leading)     |                               |
| (7) Wheel cylinder body | (17) Shoe hold-down spring    |                               |
| (8) Pin                 | (18) Cup                      |                               |
| (9) Plug                | (19) Adjusting lever          |                               |
| (10) Back plate         | (20) Adjuster                 |                               |

**Tightening torque: N·m (kg·m, ft·lb)**

**T1: 8±1 (0.8±0.1, 5.8±0.7)**

**T2: 10±2 (1.0±0.2, 7.2±1.4)**

**T3: 52±6 (5.3±0.6, 38.3±4.3)**

#### 1. BRAKE DRUM AND SHOE

- 1) Loosen wheel nuts, jack-up vehicle, support it with rigid racks, and remove wheel.
- 2) Release parking brake.

- 3) Remove brake drum from brake assembly.

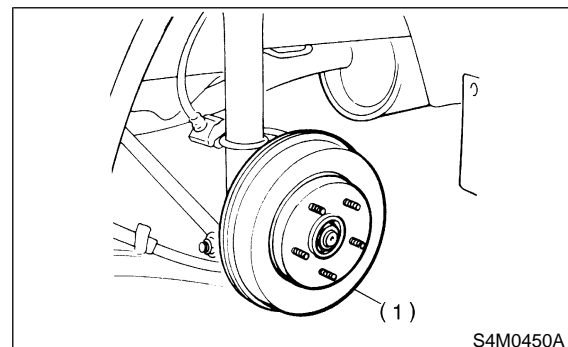

S4M0450A

- (1) Drum

3. Rear Drum Brake

NOTE:

If it is difficult to remove brake drum, remove adjusting hole cover from back plate, and then, turn adjuster assembly pawls using a slot-type screwdriver until brake shoe separates from the drum.

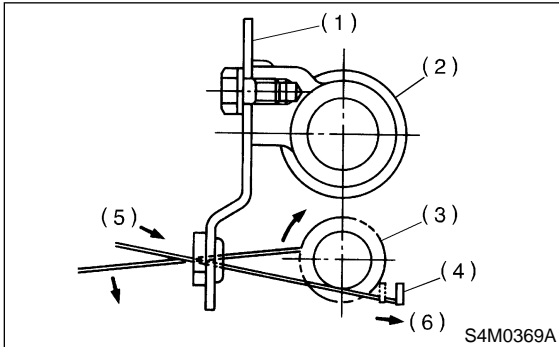

- (1) Back plate
- (2) Wheel cylinder
- (3) Adjuster ASSY pawls
- (4) Adjusting lever
- (5) Tightening direction
- (6) Push.

4) Hold hold-down pin by securing rear of back plate with your hand.

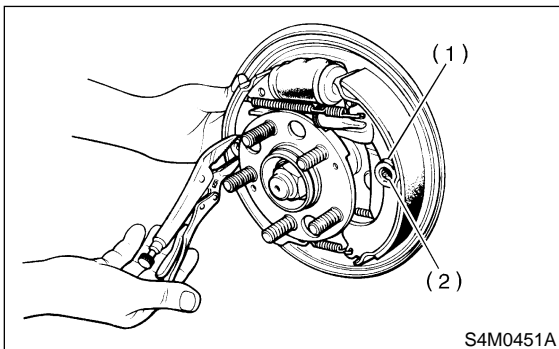

- (1) Hold-down cup
- (2) Hold-down pin

5) Disconnect hold-down cup from hold-down pin by rotating hold-down cup.

6) Disconnect lower shoe return spring from shoes.

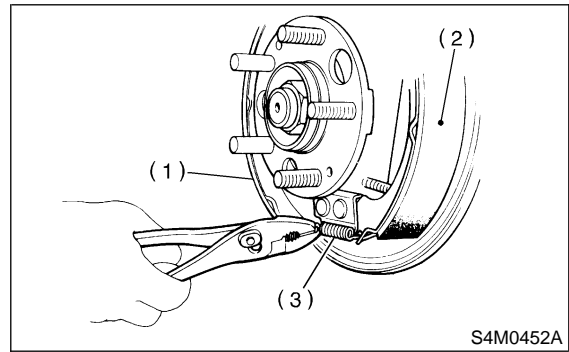

- (1) Leading shoe
- (2) Trailing shoe
- (3) Lower shoe return spring

7) Remove shoes one by one from back plate with adjuster.

**CAUTION:**

**Be careful not to bend parking brake cable excessively when removing brake shoes.**

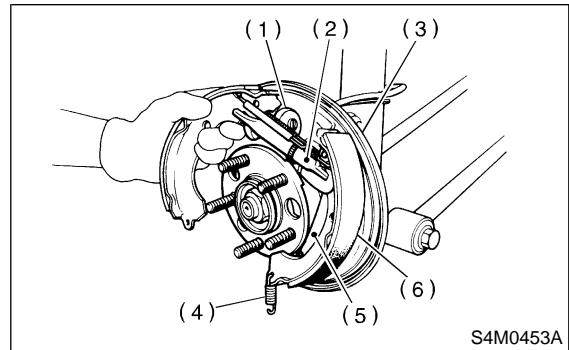

- (1) Wheel cylinder
- (2) Adjuster
- (3) Back plate
- (4) Lower shoe return spring
- (5) Parking lever
- (6) Trailing shoe

8) Disconnect parking brake cable from parking lever.

9) Remove the following:

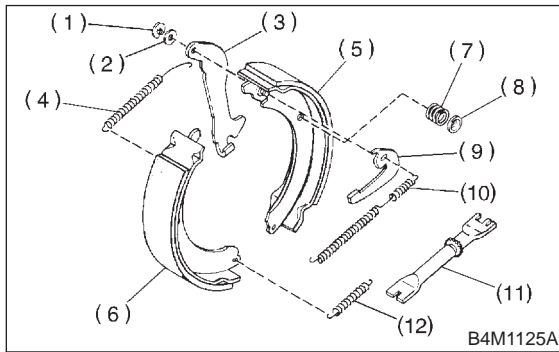

- (1) Retainer
- (2) Washer
- (3) Parking lever
- (4) Upper shoe return spring
- (5) Trailing shoe
- (6) Leading shoe
- (7) Shoe hold-down spring
- (8) Shoe hold-down cup
- (9) Adjusting lever
- (10) Adjusting spring
- (11) Adjuster
- (12) Lower shoe return spring

## 2. BRAKE ASSEMBLY

- 1) Remove wheel.
- 2) Remove axle nut.
- 3) Remove brake drum.
- 4) Unscrew the brake pipe flare nut and disconnect brake pipe.

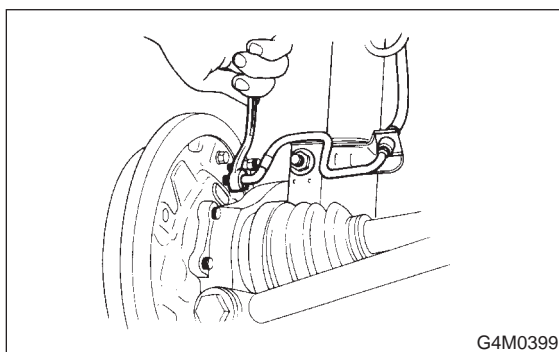

G4M0399

5) Remove hub. <Ref. to 4-2 [W2A0].>

6) Remove the bolts installing back plate, and then, remove brake assembly.

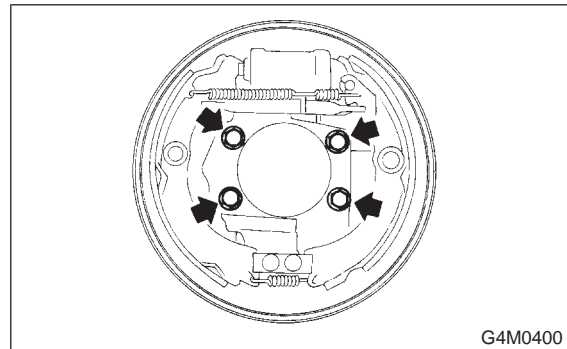

G4M0400

## 3. WHEEL CYLINDER

- 1) Remove brake drum and shoes.
- 2) Unscrew brake pipe flare nut, and disconnect brake pipe.
- 3) Remove the bolts installing wheel cylinder on back plate, and remove it.

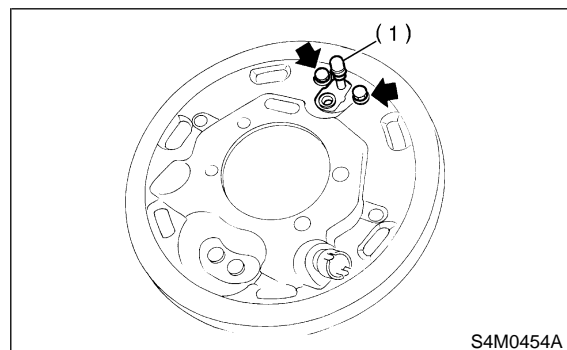

S4M0454A

(1) Air bleeder



**B: DISASSEMBLY**

**1. WHEEL CYLINDER**

1) Remove right and left dust boots from wheel cylinder.

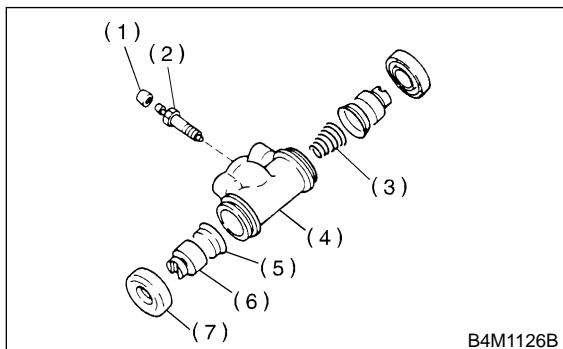

- (1) Bleeder cap
- (2) Bleeder screw
- (3) Spring
- (4) Cylinder
- (5) Cup
- (6) Piston
- (7) Boot

2) Remove piston, cup, spring and air bleeder screw and cap.

**C: INSPECTION**

1) If the inside surface of brake drum is streaked, correct the surface. And, if it is unevenly worn, taperingly streaked, or the outside surface of brake drum is damaged, correct or replace it.

2) Measure the drum inner diameter.

**Drum inner diameter: "L"**

**Standard**

**228.6 mm (9 in)**

**Service limit**

**230.6 mm (9.08 in)**

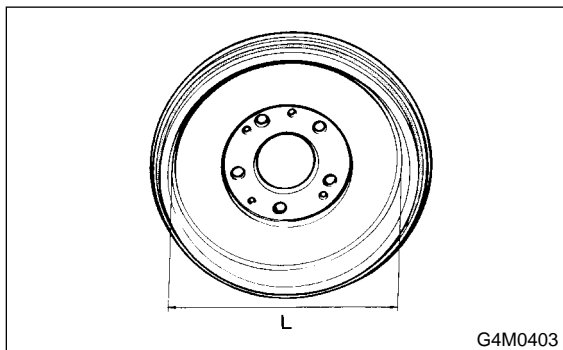

3) Measure the lining thickness.

**Lining thickness:**

**Standard**

**4.1 mm (0.161 in)**

**Service limit**

**1.5 mm (0.059 in)**

4) If the deformation or wear of back plate, shoe, etc. are notable, replace them.

5) When the shoe return spring tension is excessively weakened, replace it, taking care to identify upper and lower springs.

**D: ASSEMBLY**

**1. WHEEL CYLINDER**

1) Clean all parts in brake fluid. Check and replace faulty parts.

- Cup and boot for damage or fatigue
- Cylinder, piston and spring or damage or rust formation

2) Assemble in the reverse order of disassembly.

(1) When installing the cup, use ST, apply brake fluid to the frictional surface for smooth installation and pay attention to cup direction.

(2) STs are available in different sizes.

**CAUTION:**

● When replacing the repair kit, make sure that the sizes of cylinder and cup are the same as those which were replaced.

● Use only the tool of the correct size.

ST: ADAPTER	
Applicable size	Part No.
19.05 mm (3/4 in)	926460000

- While assembling, be careful to prevent any metal chip, dust or dirt from entering the wheel cylinder.

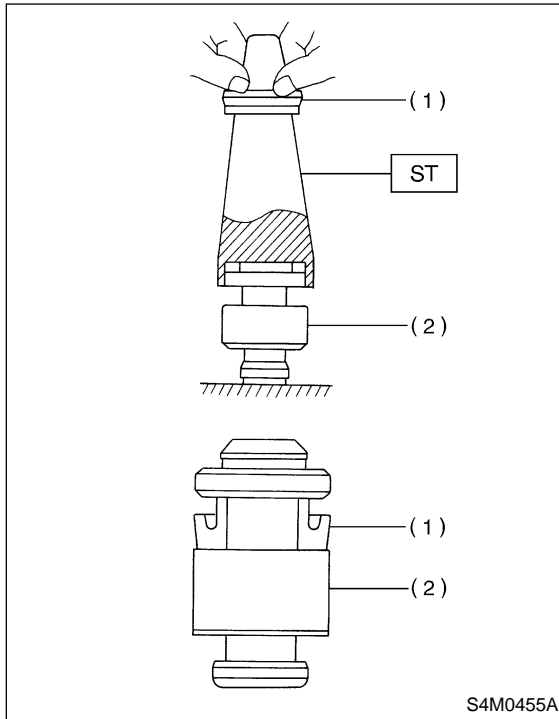

- (1) Cup
- (2) Piston

3) Apply rubber grease to the boot inside as shown in Figure.

**Grease:**  
**NIGLUBE RX-2 (Part No. 003606000)**

**CAUTION:**  
**Never use brake grease.**

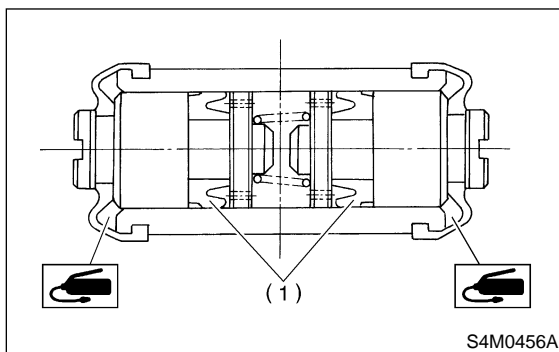

- (1) Cup

## E: INSTALLATION

### 1. WHEEL CYLINDER

Install wheel cylinder on back plate, and tighten bolts.

**Tightening torque:**  
**10±2 N·m (1.0±0.2 kg·m, 7.2±1.4 ft·lb)**

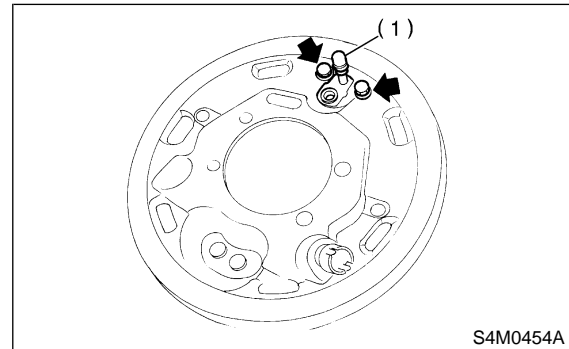

- (1) Air bleeder

### 2. BRAKE DRUM AND SHOE

- 1) Clean back plate and wheel cylinder.
- 2) Apply grease to portions indicated by arrows in Figure.

**Brake grease:**  
**Dow Corning Molykote No. 7439 (Part No. 725191460)**

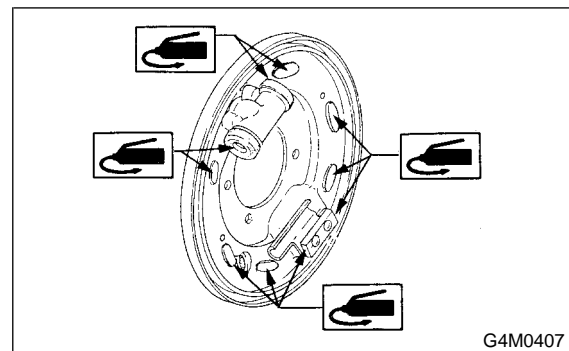

## 3. Rear Drum Brake

- 3) Apply grease to adjusting screw and both ends of adjuster.

**Brake grease:**

**Dow Corning Molykote No. 7439 (Part No. 725191460)**

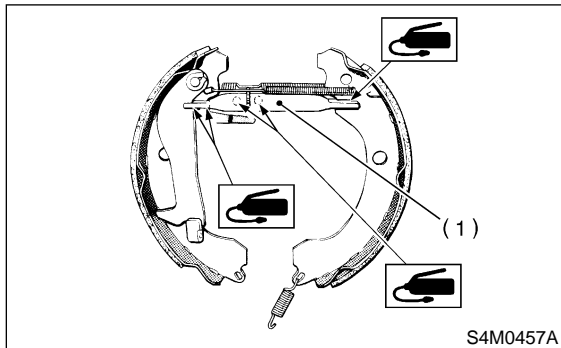

(1) Adjuster

- 4) Connect upper shoe return spring to shoes.  
5) While positioning shoes (one at a time) in groove on wheel cylinder, secure shoes.

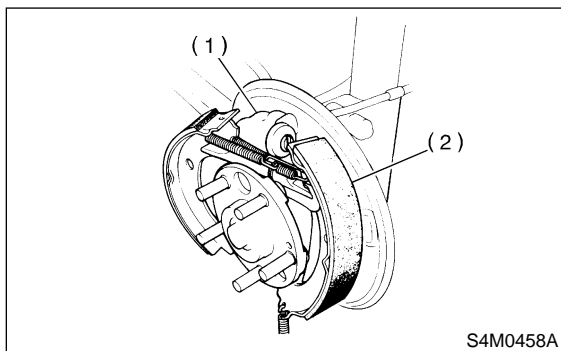

(1) Wheel cylinder  
(2) Shoe (Trailing)

- 6) Connect lower shoe return spring.  
7) Fix shoes by connecting hold-down cup to hold-down pin.

**3. BRAKE ASSEMBLY**

- 1) Install brake assembly on housing, and tighten bolts to install back plate.

**Tightening torque:**

**$52 \pm 6$  N·m ( $5.3 \pm 0.6$  kg·m,  $38.3 \pm 4.3$  ft·lb)**

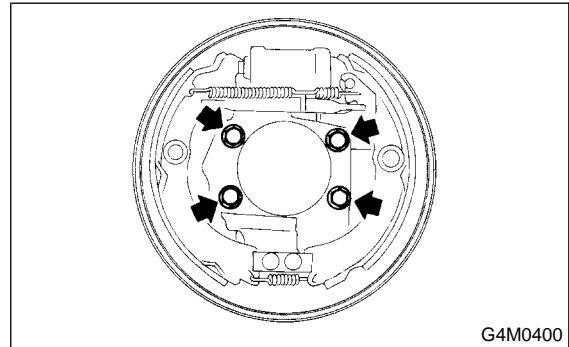

- 2) Install hub. <Ref. to 4-2 [W2D0].>  
3) Connect brake pipe, and tighten brake pipe flange nut.

**Tightening torque:**

**$15^{+3}/_{-2}$  N·m ( $1.5^{+0.3}/_{-0.2}$  kg·m,  $10.8^{+2.2}/_{-1.4}$  ft·lb)**

- 4) Set the outside diameter of brake shoes less than 0.5 to 0.8 mm (0.020 to 0.031 in) in comparison with the inside diameter of brake drum.  
5) Install brake drum.  
6) After installing brake assembly, bleed air from brake line.

## 4. Parking Brake (Rear Disc Brake)

### A: REMOVAL

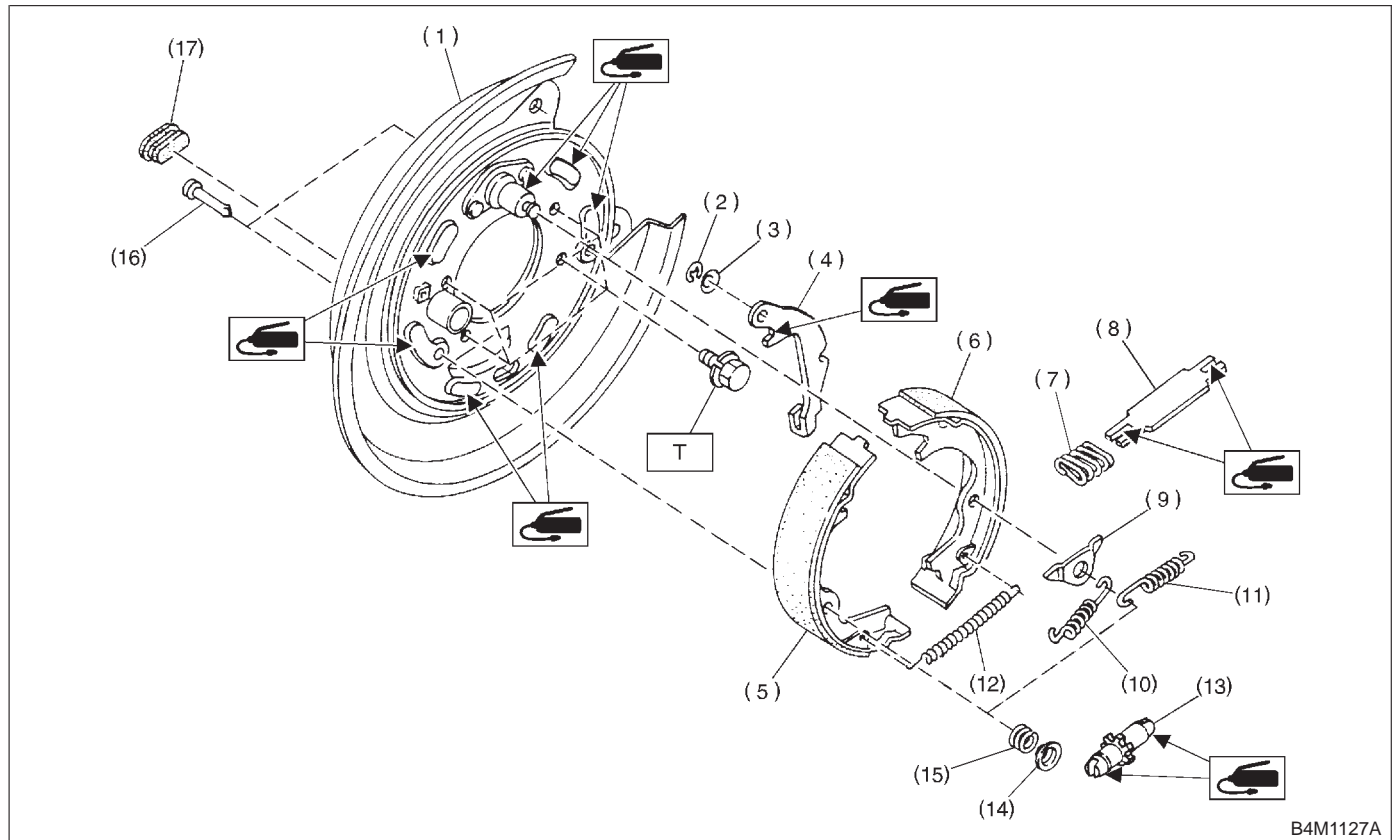

- |                                    |                              |
|------------------------------------|------------------------------|
| (1) Back plate                     | (8) Strut                    |
| (2) Retainer                       | (9) Shoe guide plate         |
| (3) Spring washer                  | (10) Primary return spring   |
| (4) Lever                          | (11) Secondary return spring |
| (5) Parking brake shoe (Primary)   | (12) Adjusting spring        |
| (6) Parking brake shoe (Secondary) | (13) Adjuster                |
| (7) Strut spring                   | (14) Shoe hold-down cup      |

- |                            |
|----------------------------|
| (15) Shoe hold down spring |
| (16) Shoe hold down pin    |
| (17) Adjusting hole cover  |

**Tightening torque: N·m (kg·m, ft·lb)**  
**T: 52±6 (5.3±0.6, 38.3±4.3)**

1) Remove the two mounting bolts to the disc brake assembly and remove the disc brake assembly.

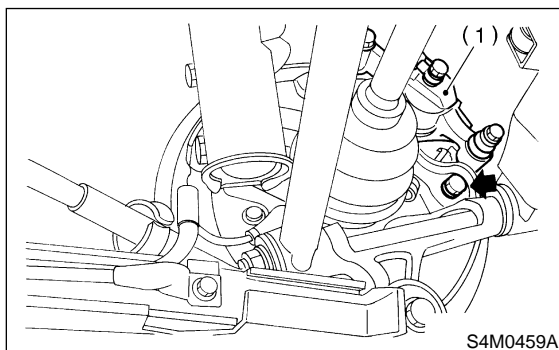

(1) Disc brake

2) Suspend the disc brake assembly so that the hose is not stretched.

- 3) Remove the disc rotor.
- 4) Remove shoe return spring from parking brake assembly.
- 5) Remove front shoe hold down spring and pin with pliers.
- 6) Remove strut and strut spring.
- 7) Remove adjuster assembly from parking brake assembly.
- 8) Remove brake shoe.
- 9) Remove rear shoe hold-down spring and pin with pliers.

4. Parking Brake (Rear Disc Brake)

10) Remove parking cable from parking lever.

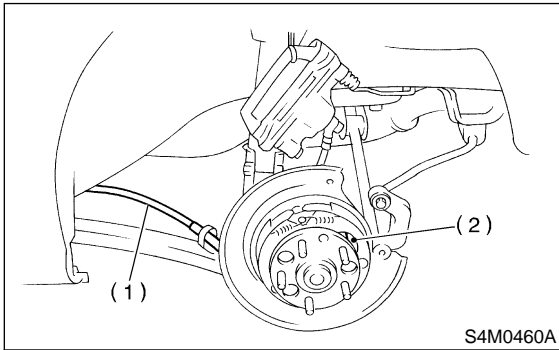

- (1) Parking brake cable
- (2) Parking brake lever

11) Using a standard screwdriver, raise retainer. Remove parking lever and washer from brake shoe.

**B: INSPECTION**

1) Measure brake disc inside diameter. If the disc is scored or worn, replace the brake disc.

**Disc inside diameter:**

**Standard**

170 mm (6.69 in)

**Service limit**

171 mm (6.73 in)

2) Measure the lining thickness. If it exceeds the limit, replace shoe assembly.

**Lining thickness:**

**Standard**

3.2 mm (0.126 in)

**Service limit**

1.5 mm (0.059 in)

**CAUTION:**

Replace the brake shoes on the right and left brake assembly at the same time.

**C: INSTALLATION**

**CAUTION:**

Be sure lining surface is free from oil contamination.

**Brake grease:**

**Dow Corning Molykote No 7439 (Part No. 725191460)**

1) Apply brake grease to the following places.

- The six contact surfaces of shoe rim and back plate packing
- Contact surface of shoe wave and anchor pin
- Contact surface of lever and strut
- Contact surface of shoe wave and adjuster assembly
- Contact surface of shoe wave and strut
- Contact surface of lever and shoe wave

2) Install in the reverse order of removal.

**CAUTION:**

- Use new retainers and clinch them when installing brake shoes to levers.
- Ensure that parking lever moves smoothly.
- Do not confuse left parking lever with right one.
- Do not confuse left strut with right one.

**NOTE:**

Ensure that adjuster assembly is securely installed with screw in the left side, facing vehicle front.

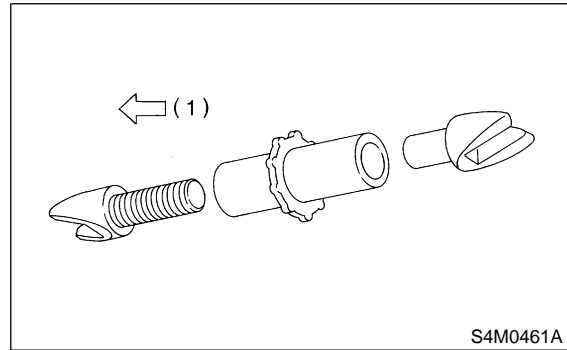

- (1) LEFT

**NOTE:**

Ensure that shoe return spring is installed as shown in Figure.

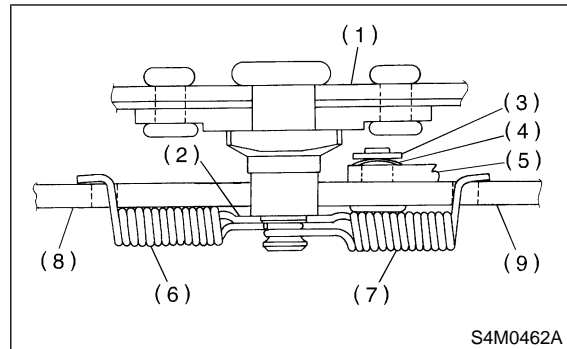

- (1) Back plate
- (2) Shoe guide plate
- (3) Retainer
- (4) Spring washer
- (5) Lever
- (6) Primary shoe return spring (Blue)
- (7) Secondary shoe return spring (Yellow)
- (8) Parking brake shoe (Primary)
- (9) Parking brake shoe (Secondary)

3) Adjust parking brakes. <Ref. to 4-4 [W4D1].>

**CAUTION:**

After replacing parking brake lining, be sure to drive vehicle for “break-in” purposes.

- (1) Drive the vehicle about 35 km/h (22 MPH).
- (2) With the parking brake release button pushed in, pull the parking brake lever gently, pulling with a force of approximately 147 N (15 kg, 33 lb).
- (3) Drive the vehicle for about 200 m (0.12 mile) in this condition.
- (4) Wait 5 to 10 minutes for the parking brake to cool down. Repeat this procedure once more.
- (5) After breaking-in, re-adjust parking brakes.

**D: ADJUSTMENT**

**1. SHOE CLEARANCE**

- 1) Remove adjusting hole cover from back plate.
- 2) Turn adjusting screw using a slot-type screwdriver until brake shoe is in close contact with disc rotor.

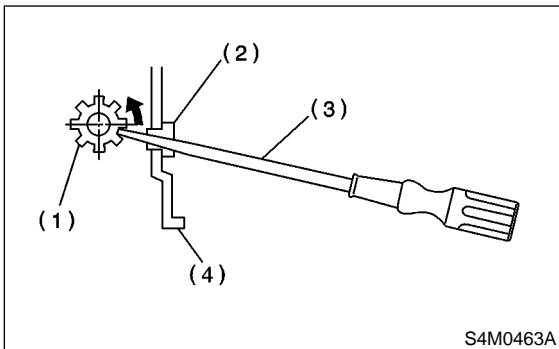

- (1) Adjusting screw
- (2) Cover (rubber)
- (3) Slot-type screwdriver
- (4) Back plate

- 3) Turn back (downward) adjusting screw 3 or 4 notches.
- 4) Install adjusting hole cover to back plate.

**2. LEVER STROKE**

- 1) Remove console box lid.
- 2) Forcibly pull parking brake lever 3 to 5 times.
- 3) Adjust parking brake lever by turning adjusting nut until parking brake lever stroke is set at 7 to 8 notches with operating force of 196 N (20 kg, 44 lb).

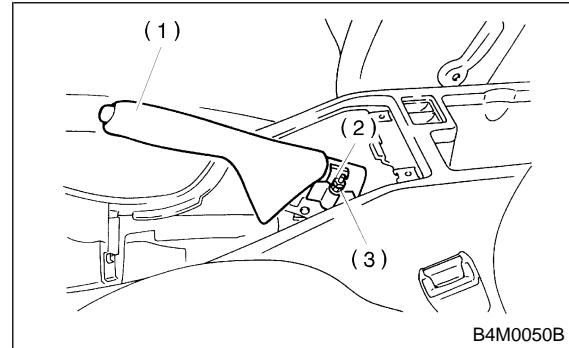

- (1) Parking brake lever
- (2) Lock nut
- (3) Adjusting nut

- 4) Tighten lock nut.
- 5) Install console box lid.

**Lever stroke:**

**7 to 8 notches when pulled with a force of 196 N (20 kg, 44 lb)**

**Tightening torque (Lock nut):**

**5.9±1.5 N·m (0.60±0.15 kg·m, 4.3±1.1 ft·lb)**

## 5. Master Cylinder

### A: REMOVAL

- 1) Thoroughly drain brake fluid from reservoir tank.
- 2) Disconnect fluid level indicator harness connector.
- 3) Remove brake pipes from master cylinder.
- 4) Remove master cylinder mounting nuts, and take out master cylinder from brake booster.

#### CAUTION:

Be extremely careful not to spill brake fluid. Brake fluid spilt on the vehicle body will harm the painted surface; wipe it off quickly if spilt.

### B: DISASSEMBLY

#### 1. PRECAUTIONS FOR DISASSEMBLING

- 1) Remove mud and dirt from the surface of brake master cylinder.
- 2) Prepare tools necessary for disassembly operation, and arrange them neatly on work bench.
- 3) Clean work bench.

#### 2. DISASSEMBLING PROCEDURE

- 1) Remove reserve tank.
- 2) Remove cylinder pin.

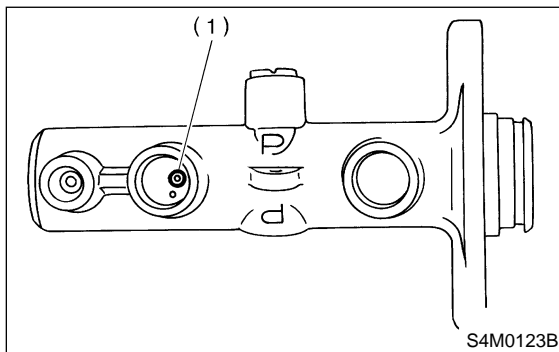

(1) Cylinder pin

- 3) Pry up the pawl and remove the piston retainer.

#### NOTE:

Piston may jump out from master cylinder.

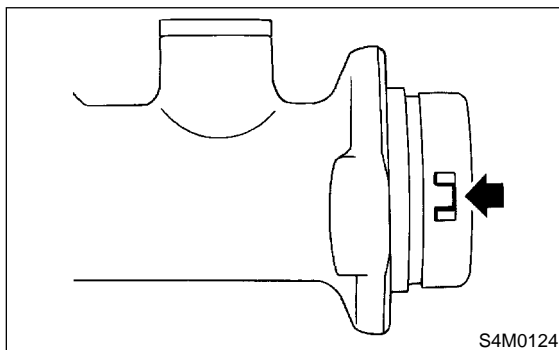

- 4) Extract primary piston assembly and secondary piston assembly.

#### CAUTION:

- Do not disassemble the piston assembly; otherwise, the spring set value may be changed.
- Use brake fluid or methanol to wash inside wall of cylinder, pistons and piston cups. Be careful not to damage parts when washing. If methanol is used for washing, do not dip rubber parts, such as piston cups, in it for more than 30 seconds; otherwise, they may become swelled.

### C: INSPECTION

If any damage, deformation, wear, swelling, rust, and other faults are found on the primary piston assembly, secondary piston assembly, supply valve stopper, or gasket, replace the faulty part.

#### CAUTION:

- The primary and secondary pistons must be replaced as complete assemblies.
- The service limit of the clearance between each piston and the master cylinder inner dia. is 0.11 mm (0.0043 in).
- When handling parts, be extremely careful not to damage or scratch the parts, or let any foreign matter get on them.

## D: ASSEMBLY

### 1. PRECAUTIONS FOR ASSEMBLING

- 1) When assembling, be sure to use recommended brake fluid.
- 2) Ensure that the inside wall of cylinder, pistons, and piston cups are free from dirt when assembling.
- 3) Be extremely careful not to damage, scratch, or dent cylinder inside wall, pistons, and piston cups.
- 4) Do not drop parts. Never attempt to use any part that has been dropped accidentally.

### 2. ASSEMBLING OPERATION

- 1) Assembling piston assembly:  
Apply recommended brake fluid to inside wall of cylinder, and to outer surface of piston assembly, and install piston assemblies carefully into cylinder.
- 2) Assembling cylinder pin:
- 3) Press the pawl and install the piston retainer into the master cylinder.

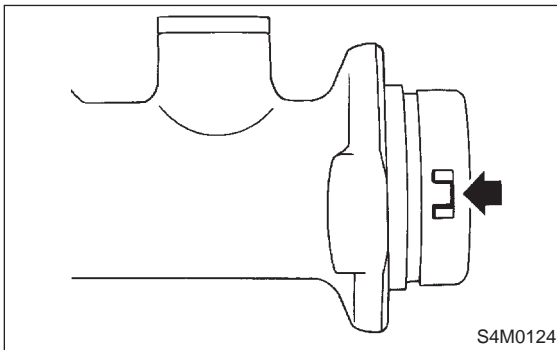

## E: INSTALLATION

Install the master cylinder to the body in the reverse order of removal.

### Tightening torque:

- Master cylinder mounting nut**  
 $14 \pm 4 \text{ N}\cdot\text{m}$  ( $1.4 \pm 0.4 \text{ kg}\cdot\text{m}$ ,  $10.1 \pm 2.9 \text{ ft}\cdot\text{lb}$ )
- Piping flare nut**  
 $15^{+3}_{-2} \text{ N}\cdot\text{m}$  ( $1.5^{+0.3}_{-0.2} \text{ kg}\cdot\text{m}$ ,  $10.8^{+2.2}_{-1.4} \text{ ft}\cdot\text{lb}$ )

### CAUTION:

Be sure to use recommended brake fluid.

## 6. Brake Booster

### A: REMOVAL

- 1) Remove or disconnect the following parts at engine compartment.
  - (1) Disconnect connector for brake fluid level indicator.
  - (2) Remove brake pipes from master cylinder.
  - (3) Remove master cylinder installing nuts.
  - (4) Disconnect vacuum hose from brake booster.
- 2) Remove the following parts from the pedal bracket.
  - (1) Snap pin and clevis pin
  - (2) The four brake booster installing nuts
- 3) Remove brake booster while shunning brake pipes.

### B: HANDLING PRECAUTIONS

- 1) Be careful not to drop brake booster. Brake booster should be discarded if it has been dropped.
- 2) Use special care when handling operating rod. If excessive force is applied to operating rod, sufficient to cause a change in the angle in excess of  $\pm 3^\circ$ , it may result in damage to the power piston cylinder.
- 3) Use care when placing brake booster on the floor.

### CAUTION:

If external force is applied from above when brake booster is placed in this position, the resin portion as indicated by "P", may be damaged.

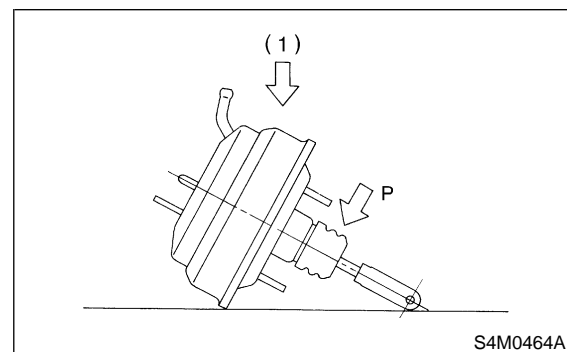

- (1) Force



**D: ASSEMBLY**

**1. PRECAUTIONS FOR ASSEMBLING**

- 1) When assembling, be sure to use recommended brake fluid.
- 2) Ensure that the inside wall of cylinder, pistons, and piston cups are free from dirt when assembling.
- 3) Be extremely careful not to damage, scratch, or dent cylinder inside wall, pistons, and piston cups.
- 4) Do not drop parts. Never attempt to use any part that has been dropped accidentally.

**2. ASSEMBLING OPERATION**

- 1) Assembling piston assembly:  
Apply recommended brake fluid to inside wall of cylinder, and to outer surface of piston assembly, and install piston assemblies carefully into cylinder.
- 2) Assembling cylinder pin:
- 3) Press the pawl and install the piston retainer into the master cylinder.

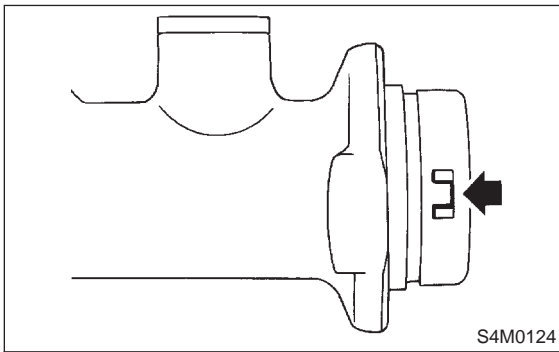

**E: INSTALLATION**

Install the master cylinder to the body in the reverse order of removal.

**Tightening torque:**

- Master cylinder mounting nut**  
14±4 N·m (1.4±0.4 kg·m, 10.1±2.9 ft·lb)
- Piping flare nut**  
15<sup>+3</sup>/<sub>-2</sub> N·m (1.5<sup>+0.3</sup>/<sub>-0.2</sub> kg·m, 10.8<sup>+2.2</sup>/<sub>-1.4</sub> ft·lb)

**CAUTION:**  
Be sure to use recommended brake fluid.

**6. Brake Booster**

**A: REMOVAL**

- 1) Remove or disconnect the following parts at engine compartment.
  - (1) Disconnect connector for brake fluid level indicator.
  - (2) Remove brake pipes from master cylinder.
  - (3) Remove master cylinder installing nuts.
  - (4) Disconnect vacuum hose from brake booster.
- 2) Remove the following parts from the pedal bracket.
  - (1) Snap pin and clevis pin
  - (2) The four brake booster installing nuts
- 3) Remove brake booster while shunning brake pipes.

**B: HANDLING PRECAUTIONS**

- 1) Be careful not to drop brake booster. Brake booster should be discarded if it has been dropped.
- 2) Use special care when handling operating rod. If excessive force is applied to operating rod, sufficient to cause a change in the angle in excess of ±3°, it may result in damage to the power piston cylinder.
- 3) Use care when placing brake booster on the floor.

**CAUTION:**  
If external force is applied from above when brake booster is placed in this position, the resin portion as indicated by "P", may be damaged.

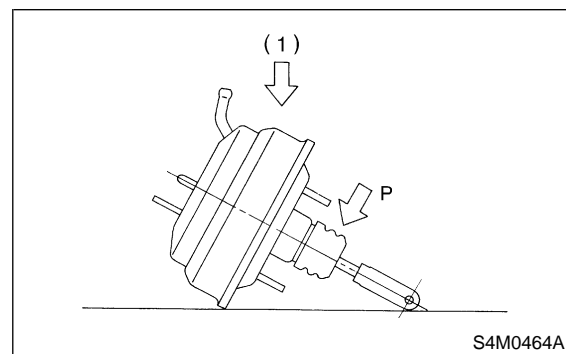

(1) Force

4) Do not change the push rod length. If it has been changed, reset the projected length "L" to the standard length.

**Standard:**

**L = 10.4 mm (0.41 in)**

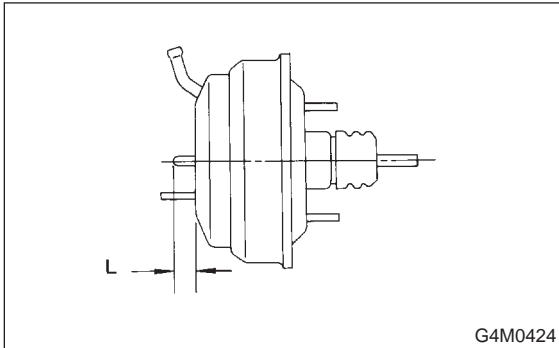

**C: INSTALLATION**

- 1) Mount brake booster in position.
- 2) Connect operating rod to brake pedal with clevis pin and snap pin.

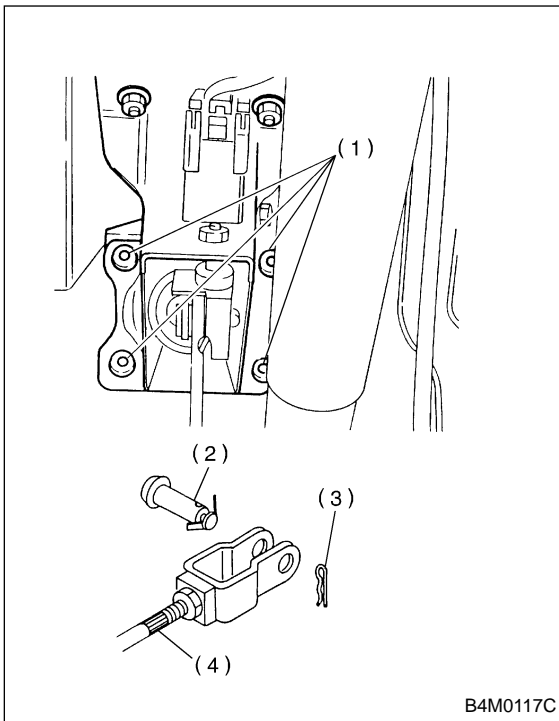

- (1) Nuts
- (2) Clevis pin
- (3) Snap pin
- (4) Operating rod

3) Connect vacuum hose to brake booster.

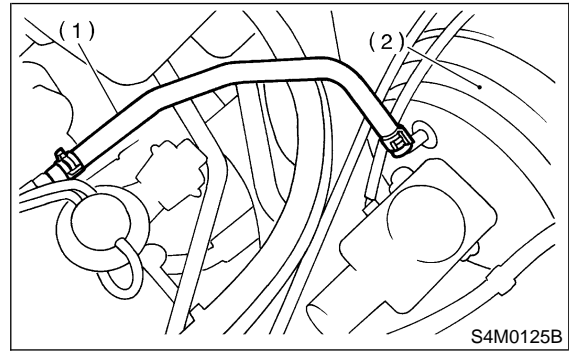

- (1) Vacuum hose
- (2) Brake booster

- 4) Mount master cylinder onto brake booster.
- 5) Connect brake pipes to master cylinder.
- 6) Connect electric connector for brake fluid level indicator.
- 7) Adjust operating rod of brake booster.

**Standard: L**

**145.3 mm (5.72 in)**

If it is not in specified value, adjust it by adjusting brake booster operating rod.

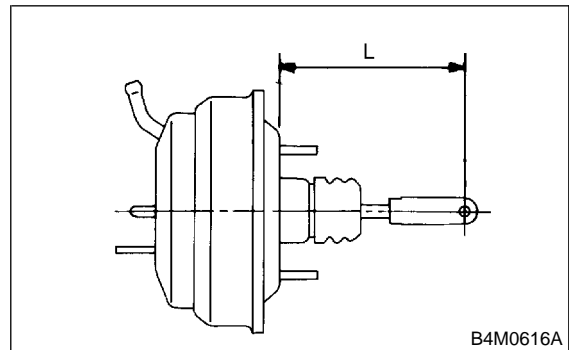

8) Measure the clearance between threaded end of stop light switch and stopper.  
If it is not in specified value, adjust it by adjusting position of stop light switch.

**CAUTION:**

Be careful not to rotate stop light switch.

**Stop light switch clearance: A**  
**0.3 mm (0.012 in)**

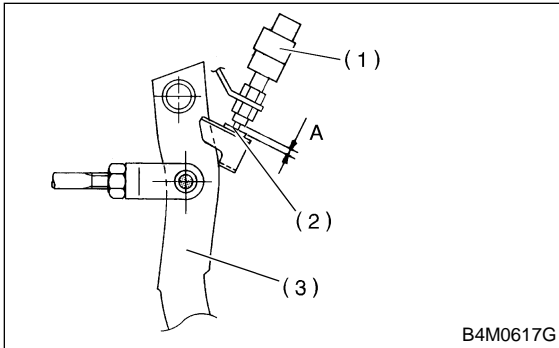

- (1) Stop light switch
- (2) Stopper
- (3) Brake pedal

9) Apply grease to operating rod connecting pin to prevent it from wearing.  
10) Bleed air from brake system.

**Tightening torque (Air bleeder screw):**  
**8±1 N·m (0.8±0.1 kg·m, 5.8±0.7 ft·lb)**

11) Conduct road tests to ensure brakes do not drag.

**D: OPERATION CHECK (WITHOUT USING GAUGES)**

**CAUTION:**

When checking operation, be sure to securely apply the hand brake.

**1. CHECKING WITHOUT USING GAUGES**

This method cannot determine the exact portion which has failed, but it can provide a rough understanding of the nature of the failure if checking is conducted in accordance with the following procedures.

**2. AIR TIGHTNESS CHECK**

Start engine, and run it for 1 to 2 minutes, then turn it off.

Depress brake pedal several times applying the same pedal force as that used in ordinary braking operations. The pedal stroke should be greatest on the 1st depression, and it should become smaller with each successive depression. If no change occurs in the pedal height while in a depressed state, brake booster is faulty.

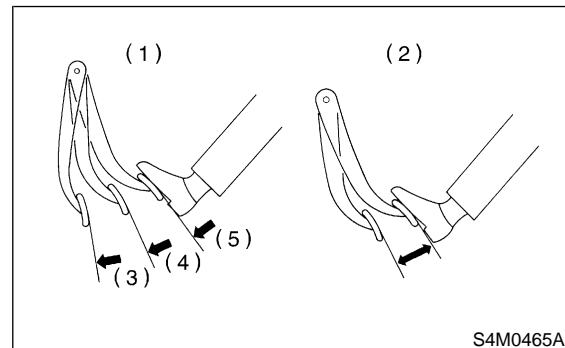

- (1) OK
- (2) NOT OK
- (3) 1st
- (4) 2nd
- (5) 3rd

**NOTE:**

- In the event of defective operation, inspect the condition of the check valve and vacuum hose.
- Replace them if faulty and conduct the test again.
- If no improvement is observed, check precisely with gauges.

### 3. OPERATION CHECK

1) With engine off, depress brake pedal several times applying the same pedal force and make sure that the pedal height does not vary with each depression of the pedal.

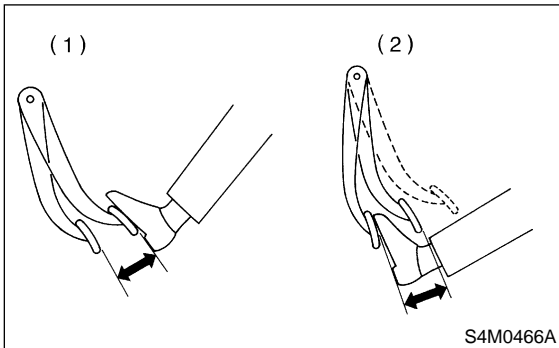

- (1) When engine is stopped.
- (2) When engine is started.

2) With brake pedal depressed, start engine.  
3) As engine starts, brake pedal should move slightly toward the floor. If no change occurs in the pedal height, brake booster is faulty.

**NOTE:**

If faulty, check precisely with gauges.

### 4. LOADED AIR TIGHTNESS CHECK

Depress brake pedal while engine is running, and turn off engine while the pedal is still depressed. Keep the pedal depressed for 30 seconds; if no change occurs in the pedal height, brake booster is functioning normally; if the pedal height increases, it is faulty.

**NOTE:**

If faulty, check precisely with gauges.

### E: OPERATION CHECK (WITH USING GAUGES)

**CAUTION:**

When checking operation, be sure to securely apply the hand brake.

#### 1. CHECKING WITH GAUGES

Connect gauges as shown in Figure. After bleeding air from pressure gauges, proceed to each check.

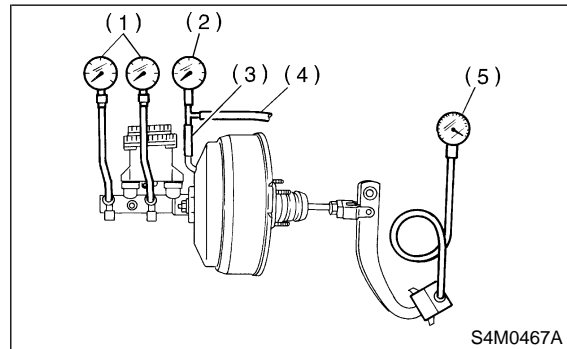

- (1) Pressure gauge
- (2) Vacuum gauge
- (3) Adapter hose
- (4) Vacuum hose
- (5) Pedal force gauge

#### 2. AIR TIGHTNESS CHECK

1) Start engine and keep it running until a vacuum of 66.7 kPa (500 mmHg, 19.69 inHg) = point A is indicated on vacuum gauge. Do not depress brake pedal.

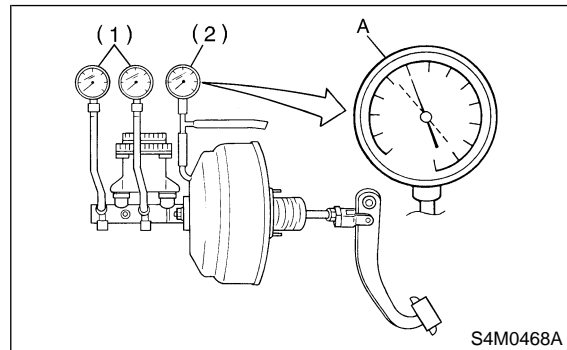

- (1) Pressure gauge
- (2) Vacuum gauge

2) Stop engine and watch the gauge. If the vacuum drop range is less than 3.3 kPa (25 mmHg, 0.98 inHg) within 15 seconds after stopping engine, brake booster is functioning properly. If defective, the cause may be one of those listed below.

- Check valve malfunction
- Leak from vacuum hose

- Leak from the shell jointed portion or stud bolt welded portion
- Damaged diaphragm
- Leak from valve body seal and bearing portion
- Leak from plate and seal assembly portion
- Leak from poppet valve assembly portion

**3. LOADED AIR TIGHTNESS CHECK**

1) Start engine and depress brake pedal with pedal force of 196 N (20 kg, 44 lb). Keep engine running until a vacuum of 66.7 kPa (500 mmHg, 19.69 inHg) = point B is indicated on vacuum gauge while the pedal is still depressed.

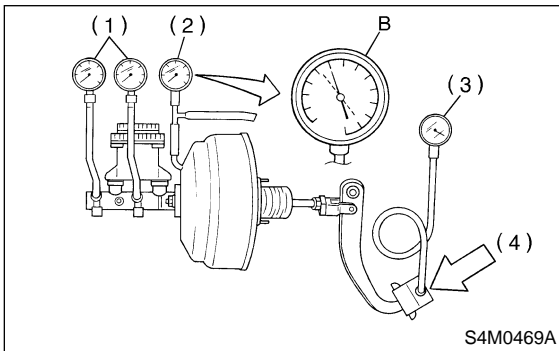

- (1) Pressure gauge
- (2) Vacuum gauge
- (3) Pedal force gauge
- (4) Depress.

2) Stop engine and watch vacuum gauge. If the vacuum drop range is less than 3.3 kPa (25 mmHg, 0.98 inHg) within 15 seconds after stopping engine, brake booster is functioning properly. If defective, refer to "AIR TIGHTNESS CHECK". <Ref. to 4-4 [W6E2].>

**4. LACK OF BOOSTING ACTION CHECK**

Turn off engine, and set the vacuum gauge reading at "0". Then, check the fluid pressure when brake pedal is depressed. The pressure must be greater than the standard value listed below.

Brake pedal force	147 N (15 kg, 33 lb)	294 N (30 kg, 66 lb)
Fluid pressure	588 kPa (6 kg/cm <sup>2</sup> , 85 psi)	1,765 kPa (18 kg/cm <sup>2</sup> , 256 psi)

**5. BOOSTING ACTION CHECK**

Set the vacuum gauge reading at 66.7 kPa (500 mmHg, 19.69 inHg) by running engine. Then, check the fluid pressure when brake pedal is depressed. The pressure must be greater than the standard value listed below.

Brake pedal force	147 N (15 kg, 33 lb)	294 N (30 kg, 66 lb)
Fluid pressure	5,590 kPa (57 kg/cm <sup>2</sup> , 811 psi)	9,807 kPa (100 kg/cm <sup>2</sup> , 1,422 psi)

## 7. Brake Hose

### A: REMOVAL

- 1) Separate brake pipe from brake hose.  
(Always use flare nut wrench and be careful not to deform flare nut.)

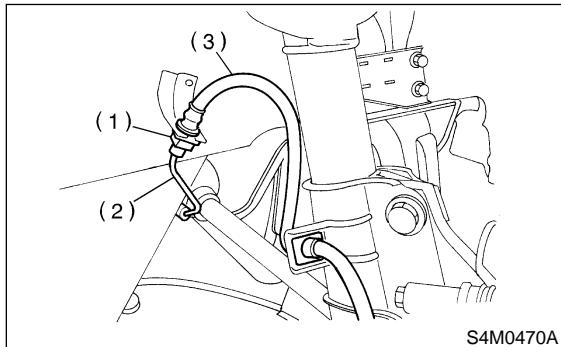

- (1) Clamp
- (2) Brake pipe
- (3) Brake hose

- 2) Pull out clamp to remove brake hose.
- 3) Remove clamp at strut and union bolt.

### B: INSTALLATION

#### 1. FRONT BRAKE HOSE

- 1) Route end of brake hose (on caliper side) through hole in brake hose bracket at strut location.
- 2) Tighten end of brake hose at caliper using a union bolt.

**Tightening torque (Union bolt):**  
 $18 \pm 3 \text{ N}\cdot\text{m}$  ( $1.8 \pm 0.3 \text{ kg}\cdot\text{m}$ ,  $13.0 \pm 2.2 \text{ ft}\cdot\text{lb}$ )

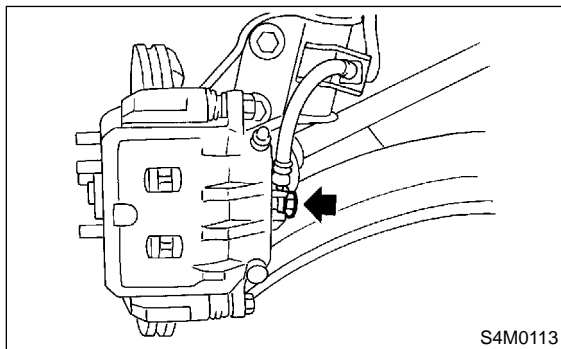

- 3) Secure middle fitting of brake hose to bracket at strut location using a clamp.
- 4) Position disc in straight-forward direction and route brake hose through hole in bracket on wheel apron side.

#### CAUTION:

**Be sure brake hose is not twisted.**

- 5) Temporarily tighten flare nut to connect brake pipe and hose.

- 6) Fix brake hose with clamp at wheel apron bracket.
- 7) While holding hexagonal part of brake hose fitting with a wrench, tighten flare nut to the specified torque.

**Tightening torque (Brake pipe flare nut):**  
 $15^{+3}_{-2} \text{ N}\cdot\text{m}$  ( $1.5^{+0.3}_{-0.2} \text{ kg}\cdot\text{m}$ ,  $10.8^{+2.2}_{-1.4} \text{ ft}\cdot\text{lb}$ )

- 8) Bleed air from the brake system.

#### 2. REAR BRAKE HOSE

- 1) Pass brake hose through the hole of bracket, and lightly tighten flare nut to connect brake pipe.
- 2) Insert clamp upward to fix brake hose.
- 3) While holding hexagonal part of brake hose fitting with a wrench, tighten flare nut to the specified torque.

**Tightening torque (Brake pipe flare nut):**  
 $15^{+3}_{-2} \text{ N}\cdot\text{m}$  ( $1.5^{+0.3}_{-0.2} \text{ kg}\cdot\text{m}$ ,  $10.8^{+2.2}_{-1.4} \text{ ft}\cdot\text{lb}$ )

- 4) Bleed air from the brake system.

## 8. Parking Brake Lever

### A: REPLACEMENT

- 1) Remove console box from front floor.
- 2) Disconnect electric connector for parking brake switch.
- 3) Loosen parking brake adjuster, and remove inner cable end from equalizer.
- 4) Remove parking brake lever.
- 5) Install parking brake lever in the reverse order of removal.

**Torque (Lever installing bolt):**

**$18 \pm 5 \text{ N}\cdot\text{m}$  ( $1.8 \pm 0.5 \text{ kg}\cdot\text{m}$ ,  $13.0 \pm 3.6 \text{ ft}\cdot\text{lb}$ )**

- 6) Adjust parking brake lever by turning adjuster until parking brake lever stroke is set at 7 to 8 notches with operating force of 196 N (20 kg, 44 lb).
- 7) Tighten lock nut.

**Torque (Adjuster lock nut):**

**$5.9 \pm 1.5 \text{ N}\cdot\text{m}$  ( $0.60 \pm 0.15 \text{ kg}\cdot\text{m}$ ,  $4.3 \pm 1.1 \text{ ft}\cdot\text{lb}$ )**

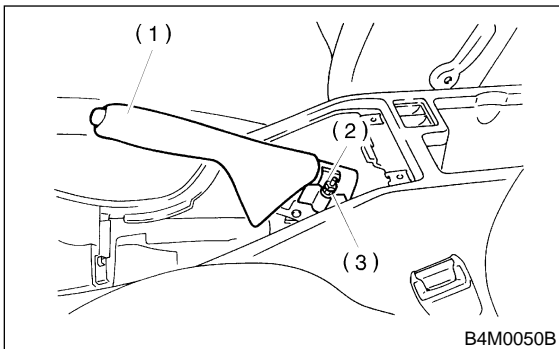

- (1) Parking brake lever
- (2) Lock nut
- (3) Adjusting nut

### B: PARKING BRAKE ADJUSTMENT

#### 1. LEVER STROKE ADJUSTMENT

- 1) Remove console cover.
- 2) Forcibly pull parking brake lever 3 to 5 times.
- 3) Adjust parking brake lever by turning adjuster until parking brake lever stroke is set at 7 to 8 notches with operating force of 196 N (20 kg, 44 lb).

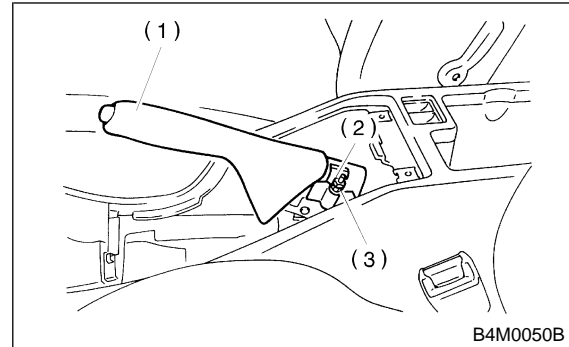

- (1) Parking brake lever
- (2) Lock nut
- (3) Adjusting nut

- 4) Tighten lock nut.

**Lever stroke:**

**7 to 8 notches when pulled with a force of 196 N (20 kg, 44 lb)**

**Tightening torque (Lock nut):**

**$5.9 \pm 1.5 \text{ N}\cdot\text{m}$  ( $0.60 \pm 0.15 \text{ kg}\cdot\text{m}$ ,  $4.3 \pm 1.1 \text{ ft}\cdot\text{lb}$ )**

- 5) Install console cover.

## 9. Parking Brake Cable

### A: REPLACEMENT

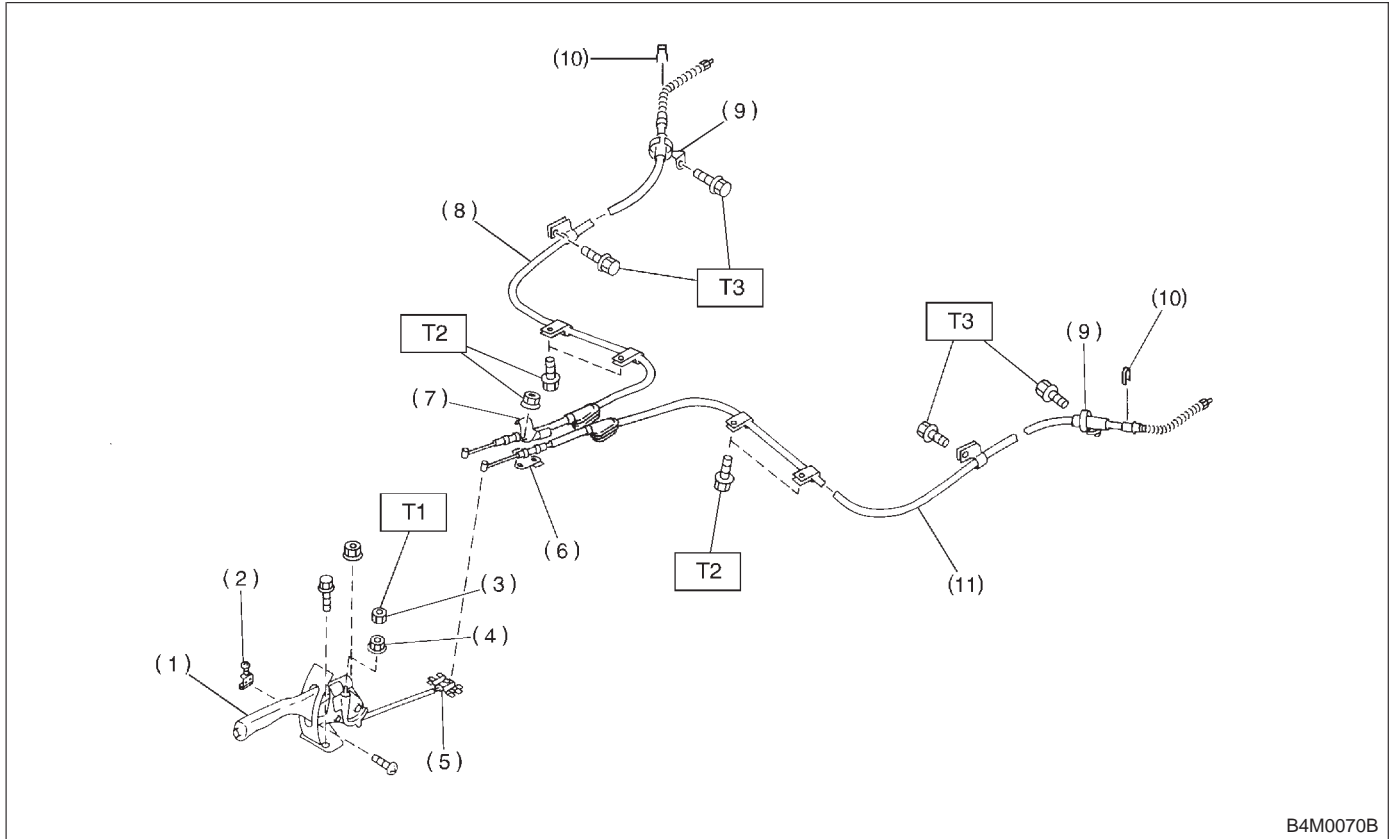

- |                          |   |
|--------------------------|---|
| (1) Parking brake lever  | (7) Clamp                               |
| (2) Parking brake switch | (8) Parking brake cable RH              |
| (3) Lock nut             | (9) Cable guide                         |
| (4) Adjusting nut        | (10) Clamp (Rear disc brake model only) |
| (5) Equalizer            | (11) Parking brake cable LH             |
| (6) Bracket              |   |

**Tightening torque: N-m (kg-m, ft-lb)**

**T1: 5.9±1.5 (0.60±0.15, 4.3±1.1)**

**T2: 18±5 (1.8±0.5, 13.0±3.6)**

**T3: 32±10 (3.3±1.0, 24±7)**

- 1) Lift-up vehicle.
- 2) Remove rear tires and wheels.
- 3) Remove rear cushion.
- 4) Remove console box from front floor.
- 5) Loosen parking cable adjusting nut and console bracket.

- 6) Remove parking brake lever.

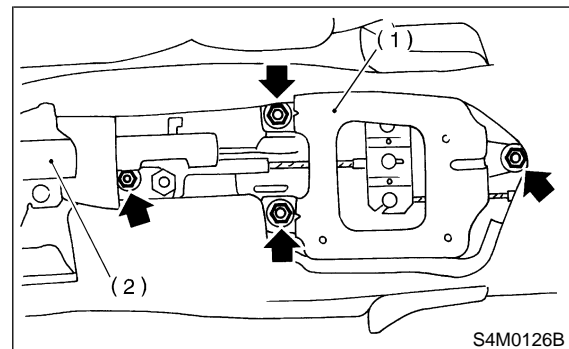

- (1) Console bracket
- (2) Parking brake lever



7) Unbend parking brake lever pawls and remove cable.

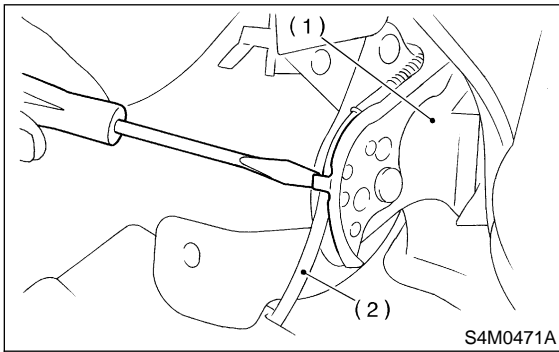

- (1) Parking brake lever
- (2) Cable

8) Roll up floor mat and remove clamps.

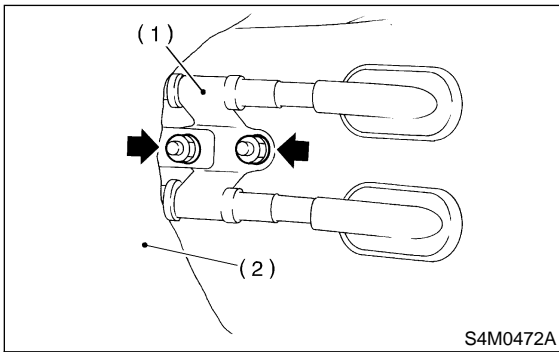

- (1) Clamp
- (2) Floor mat

9) Remove equalizer cover.

10) Remove inner cable end from equalizer.

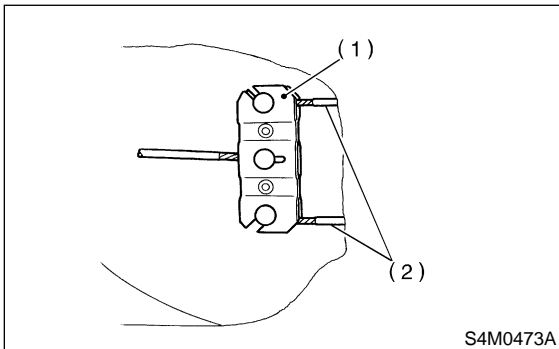

- (1) Equalizer
- (2) Inner cable end

11) Pull out parking brake cable from rear brake.  
<Ref. to 4-4 [W2A0].>

12) Pull out clamp from rear brake.

13) Remove bolt and bracket from trailing link bracket.

14) Remove bolt and clamp from rear floor.

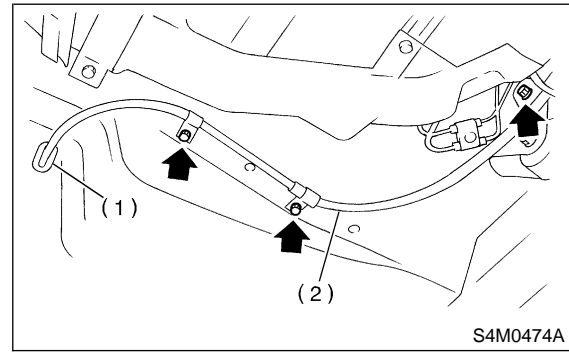

- (1) Grommet
- (2) Inner cable end

15) Detach grommet from rear floor.

16) Remove cable assembly from cabin by forcibly pulling it backward.

17) Detach parking brake cable from cable guide at rear trailing link.

18) Install (new) parking brake assembly in the reverse order of removal.

**NOTE:**

- Be sure to pass cable through cable guide inside the tunnel.
- Be sure to adjust the lever stroke. <Ref. to 4-4 [W8B1].>

## 10. Air Bleeding

### A: GENERAL RULES FOR EFFECTIVE BLEEDING

- 1) Start with the brakes (wheels) connecting to the secondary chamber of the master cylinder.
- 2) The time interval between the two brake pedal operations (from the time when the pedal is released to the time when it is depressed another time) shall be approximately 3 seconds.
- 3) The air bleeder on each brake shall be released for 1 to 2 seconds.

### B: BLEEDING PROCEDURE

#### CAUTION:

- The FMVSS No. 116, fresh DOT3 or 4 brake fluid must be used.
- Cover bleeder with waste cloth, when loosening it, to prevent brake fluid from being splashed over surrounding parts.
- Avoid mixing different brands of brake fluid to prevent degrading the quality of the fluid.
- Be careful not to allow dirt or dust to get into the reservoir tank.

#### NOTE:

- During bleeding operation, keep the brake reserve tank filled with brake fluid to eliminate entry of air.
- Brake pedal operating must be very slow.
- For convenience and safety, it is advisable to have two men working.

- 1) Make sure that there is no leak from joints and connections of the brake system.
- 2) Fit one end of vinyl tube into the air bleeder and put the other end into a brake fluid container.

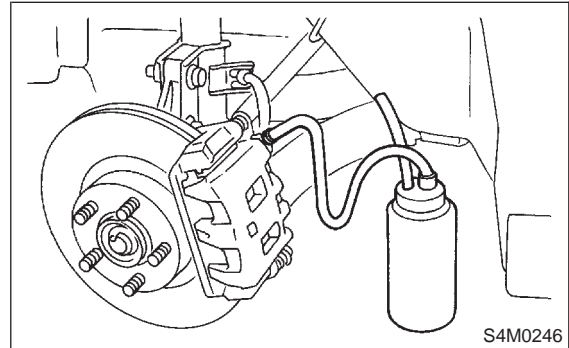

#### CAUTION:

**Brake fluid replacement sequence; (A) Front right → (B) Rear left → (C) Front left → (D) Rear right**

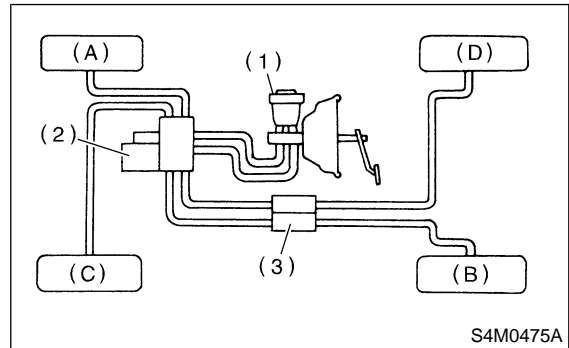

- (1) Master cylinder
- (2) Hydraulic unit
- (3) Proportioning valve

- 3) Slowly depress the brake pedal and keep it depressed. Then, open the air bleeder to discharge air together with the fluid. Release air bleeder for 1 to 2 seconds. Next, with the bleeder closed, slowly release the brake pedal. Repeat these steps until there are no more air bubbles in the vinyl tube. Allow 3 to 4 seconds between the two brake pedal operations.

#### CAUTION:

**Cover bleeder with waste cloth, when loosening it, to prevent brake fluid from being splashed over surrounding parts.**

#### NOTE:

Brake pedal operating must be very slow.

- 4) Tighten air bleeder securely when no air bubbles are visible.

#### **Air bleeder tightening torque:**

**$8 \pm 1$  N·m ( $0.8 \pm 0.1$  kg·m,  $5.8 \pm 0.7$  ft·lb)**

5) Perform these steps for the brakes connecting to the secondary chamber of master cylinder, first, and then for the ones connecting to primary chamber. With all procedures completed, fully depress the brake pedal and keep it in that position for approximately 20 seconds to make sure that there is no leak evident in the entire system.

6) Check the pedal stroke.

While the engine is idling, depress the brake pedal with a 490 N (50 kg, 110 lb) load and measure the distance between the brake pedal and steering wheel. With the brake pedal released, measure the distance between the pedal and steering wheel again. The difference between the two measurements must be more than specified.

If the distance is more than the specifications, there is a possibility that air is in the brake line. Bleed air from the brake line.

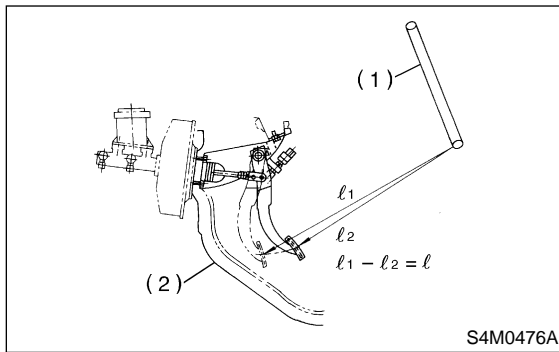

- (1) Steering wheel  
(2) Toe board

#### **Specified pedal stroke:**

**95 mm (3.74 in)**

**When depressing brake pedal with a 490 N (50 kg, 110 lb) load.**

7) After air bleeding is completed, operate sequence control to check pedal stroke. If it is longer than specified, repeat air bleeding operation. <Ref. to 4-4 [W15D0].>

8) Add brake fluid to the required level (MAX. level) of reservoir tank.

9) As a final step, test run the vehicle at low speed and apply brakes relatively hard 2 to 3 times to ensure that brakes provide normal braking action on all four wheels without dragging and uneven braking.

## 11. Brake Fluid

### A: REPLACEMENT

#### CAUTION:

- To always maintain the brake fluid characteristics, replace the brake fluid according to maintenance schedule or earlier than that when used in severe condition.
- The FMVSS No. 116, fresh DOT3 or 4 brake fluid must be used.
- Cover bleeder with waste cloth, when loosening it, to prevent brake fluid from being splashed over surrounding parts.
- Avoid mixing different brands of brake fluid to prevent degrading the quality of the fluid.
- Be careful not to allow dirt or dust to get into the reservoir tank.

#### NOTE:

- During bleeding operation, keep the brake reservoir tank filled with brake fluid to eliminate entry of air.
- Brake pedal operating must be very slow.
- For convenience and safety, it is advisable to have two men working.
- The amount of brake fluid required is approximately 500 ml (16.9 US fl oz, 17.6 Imp fl oz) for total brake system.

- 1) Either jack-up vehicle and place a safety stand under it, or left up vehicle.
- 2) Remove both front and rear wheels.
- 3) Draw out the brake fluid from master cylinder with syringe.
- 4) Refill reservoir tank with recommended brake fluid.

#### **Recommended brake fluid:**

**FMVSS No. 116, fresh DOT3 or 4 brake fluid**

5) Perform these steps for the brakes connecting to the secondary chamber of master cylinder, first, and then for the ones connecting to primary chamber. With all procedures completed, fully depress the brake pedal and keep it in that position for approximately 20 seconds to make sure that there is no leak evident in the entire system.

6) Check the pedal stroke.

While the engine is idling, depress the brake pedal with a 490 N (50 kg, 110 lb) load and measure the distance between the brake pedal and steering wheel. With the brake pedal released, measure the distance between the pedal and steering wheel again. The difference between the two measurements must be more than specified.

If the distance is more than the specifications, there is a possibility that air is in the brake line. Bleed air from the brake line.

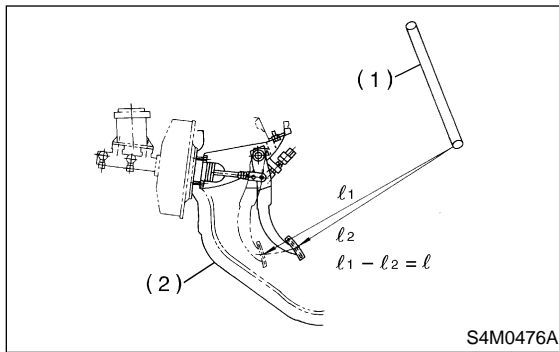

- (1) Steering wheel  
(2) Toe board

#### **Specified pedal stroke:**

**95 mm (3.74 in)**

**When depressing brake pedal with a 490 N (50 kg, 110 lb) load.**

7) After air bleeding is completed, operate sequence control to check pedal stroke. If it is longer than specified, repeat air bleeding operation. <Ref. to 4-4 [W15D0].>

8) Add brake fluid to the required level (MAX. level) of reservoir tank.

9) As a final step, test run the vehicle at low speed and apply brakes relatively hard 2 to 3 times to ensure that brakes provide normal braking action on all four wheels without dragging and uneven braking.

## 11. Brake Fluid

### A: REPLACEMENT

#### CAUTION:

● To always maintain the brake fluid characteristics, replace the brake fluid according to maintenance schedule or earlier than that when used in severe condition.

● The FMVSS No. 116, fresh DOT3 or 4 brake fluid must be used.

● Cover bleeder with waste cloth, when loosening it, to prevent brake fluid from being splashed over surrounding parts.

● Avoid mixing different brands of brake fluid to prevent degrading the quality of the fluid.

● Be careful not to allow dirt or dust to get into the reservoir tank.

#### NOTE:

● During bleeding operation, keep the brake reservoir tank filled with brake fluid to eliminate entry of air.

● Brake pedal operating must be very slow.

● For convenience and safety, it is advisable to have two men working.

● The amount of brake fluid required is approximately 500 ml (16.9 US fl oz, 17.6 Imp fl oz) for total brake system.

1) Either jack-up vehicle and place a safety stand under it, or left up vehicle.

2) Remove both front and rear wheels.

3) Draw out the brake fluid from master cylinder with syringe.

4) Refill reservoir tank with recommended brake fluid.

#### **Recommended brake fluid:**

**FMVSS No. 116, fresh DOT3 or 4 brake fluid**

5) Install one end of a vinyl tube onto the air bleeder of and insert the other end of the tube into a container to collect the brake fluid.

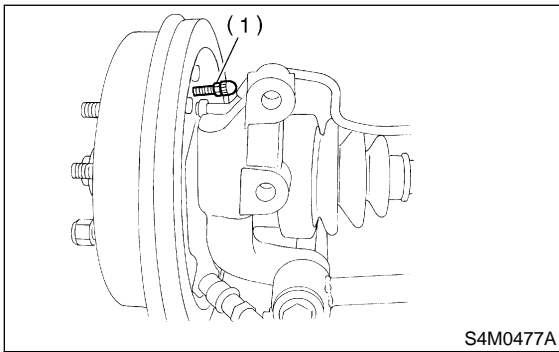
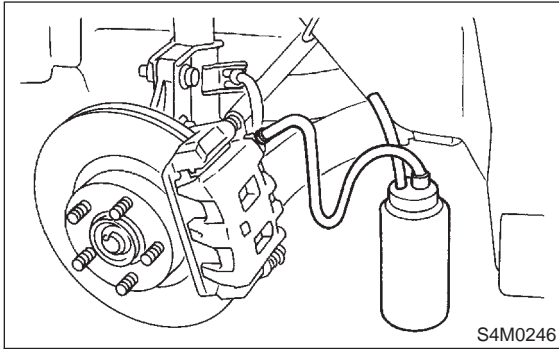

(1) Air bleeder screw

**CAUTION:**

**Brake fluid replacement sequence; (A) Front right → (B) Rear left → (C) Front left → (D) Rear right**

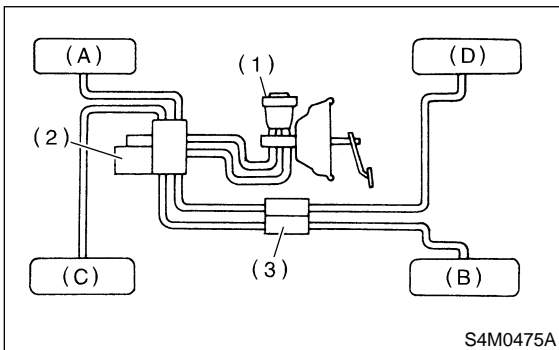

- (1) Master cylinder
- (2) Hydraulic unit
- (3) Proportioning valve

6) Instruct your co-worker to depress the brake pedal slowly two or three times and then hold it depressed.

7) Loosen bleeder screw approximately 1/4 turn until a small amount of brake fluid drains into container, and then quickly tighten screw.

8) Repeat steps 6) and 7) above until there are no air bubbles in drained brake fluid and new fluid flows through vinyl tube.

**NOTE:**

Add brake fluid as necessary while performing the air bleed operation, in order to prevent the tank from running short of brake fluid.

9) After completing the bleeding operation, hold brake pedal depressed and tighten screw and install bleeder cap.

**Tightening torque (Bleeder screw):**

**$8 \pm 1 \text{ N}\cdot\text{m}$  ( $0.8 \pm 0.1 \text{ kg}\cdot\text{m}$ ,  $5.8 \pm 0.7 \text{ ft}\cdot\text{lb}$ )**

10) Bleed air from each wheel cylinder using the same procedures as described in steps 6) through 7) above.

11) Depress brake pedal with a force of approximately 294 N (30 kg, 66 lb) and hold it there for approximately 20 seconds. At this time check pedal to see if it shows any unusual movement.

Visually inspect bleeder screws and brake pipe joints to make sure that there is no fluid leakage.

12) Install wheels, and drive vehicle for a short distance between 2 to 3 km (1 to 2 miles) to make sure that brakes are operating properly.

## 12. Proportioning Valve

### A: INSPECTION

- 1) Install the oil pressure gauges to measure the master cylinder fluid pressure (front wheel brake fluid pressure) and rear wheel cylinder fluid pressure.
- 2) Bleed air from the oil pressure gauges.
- 3) Check the master cylinder fluid pressure and rear wheel cylinder fluid pressure.  
The standard values are shown in Figure.

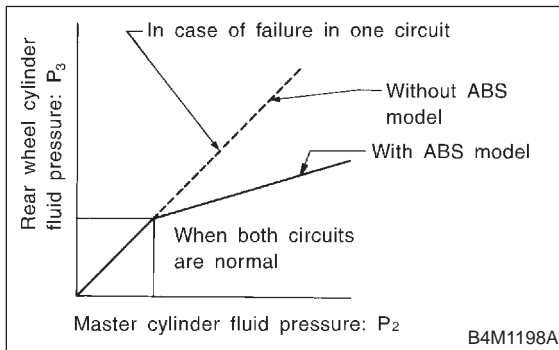

- 4) For the oil pressure in case of split point, refer to SPECIFICATIONS. <Ref. to 4-4 [S1A0].>

### B: REMOVAL

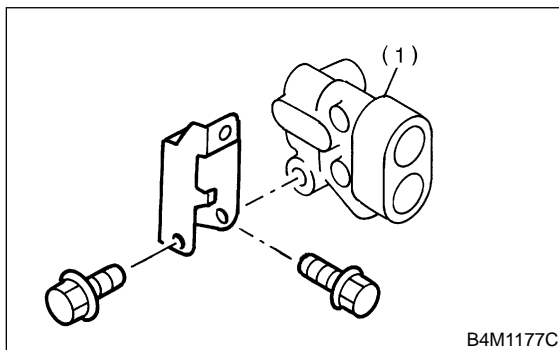

(1) Proportioning valve

- 1) Remove brake pipe from proportioning valve at four places.
- 2) Remove proportioning valve from its bracket.

#### CAUTION:

**Do not disassemble or adjust the proportioning valve. (The proportioning valve must be replaced as an assembly.)**

### C: INSTALLATION

- 1) Install proportioning valve to bracket.
- 2) Connect brake pipes correctly to proportioning valve.
- 3) Bleed air, then check each joint of brake pipe for oil leaks.

#### Tightening torque:

**Proportioning valve to brake pipe flare nut:**  
 $15^{+3}/_{-2}$  N·m ( $1.5^{+0.3}/_{-0.2}$  kg·m,  $10.8^{+2.2}/_{-1.4}$  ft·lb)

**Proportioning valve to bracket:**  
 $18 \pm 5$  N·m ( $1.8 \pm 0.5$  kg·m,  $13.0 \pm 3.6$  ft·lb)

## 13. ABS Sensor

### A: REMOVAL

#### 1. FRONT ABS SENSOR

- 1) Disconnect front ABS sensor connector located in engine compartment.
- 2) Remove bolts which secure sensor harness to strut.

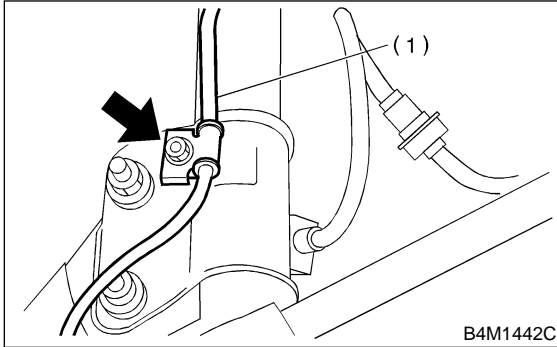

(1) Sensor harness

- 3) Remove bolts which secure sensor harness to body.

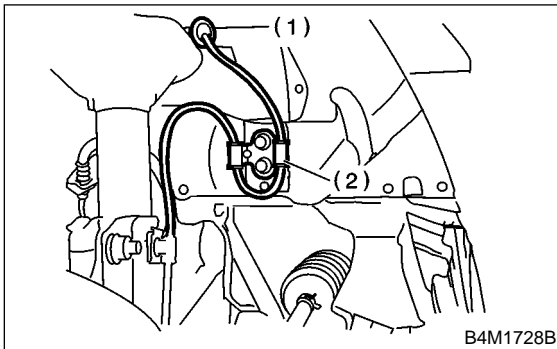

(1) To front ABS sensor connector  
(2) Bracket

- 4) Remove bolts which secure front ABS sensor to housing, and remove front ABS sensor.

#### CAUTION:

- Be careful not to damage pole piece located at tip of the sensor and teeth faces during removal.
- Do not pull sensor harness during removal.

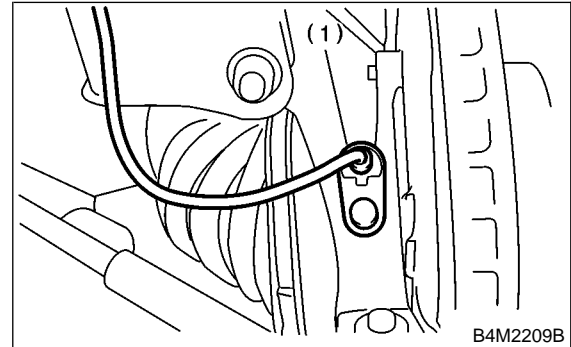

(1) Front ABS sensor

- 5) Remove front disc brake caliper and disc rotor from housing after removing front tire.
- 6) Remove front drive shaft and housing and hub assembly. <Ref. to 4-2 [W1A0].>

#### 2. REAR ABS SENSOR

- 1) Remove rear seat and disconnect rear ABS sensor connector.
- 2) Remove rear sensor harness bracket from rear trailing link and bracket.
- 3) Remove rear ABS sensor from rear back plate.

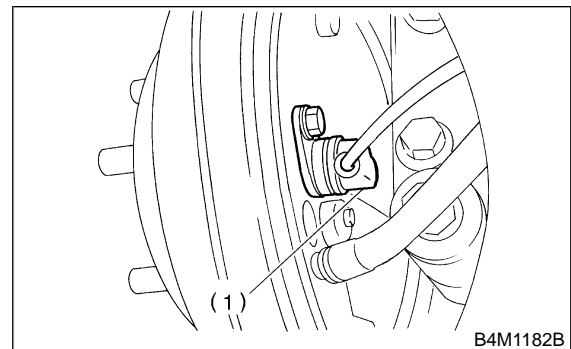

(1) Rear ABS sensor

- 4) Remove rear tone wheel while removing hub from housing and hub assembly. <Ref. to 4-2 [W2A0].>

#### CAUTION:

- Be careful not to damage pole piece located at tip of the sensor and teeth faces during removal.
- Do not pull sensor harness during removal.

**B: INSPECTION**

**1. ABS SENSOR**

- 1) Check pole piece of ABS sensor for foreign particles or damage. If necessary, clean pole piece or replace ABS sensor.
- 2) Measure ABS sensor resistance.

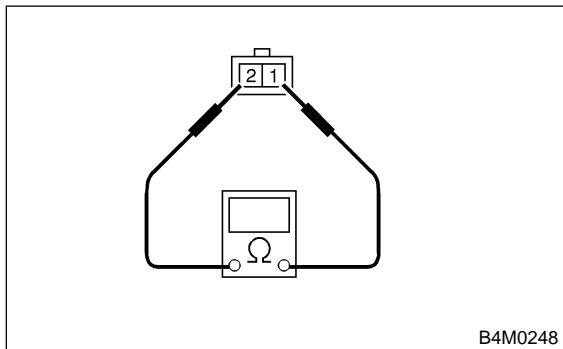

ABS sensor	Terminal No.	Standard
Front - LH	1 and 2	1.25±0.25 kΩ
Front - RH	1 and 2	
Rear - LH	1 and 2	1.0±0.2 kΩ
Rear - RH	1 and 2	

**CAUTION:**

If resistance is outside the standard value, replace ABS sensor with a new one.

**NOTE:**

Check ABS sensor cable for discontinuity. If necessary, replace with a new one.

**2. TONE WHEEL**

- 1) Check tone wheel's teeth (44 pieces) for cracks or dents. If necessary, replace tone wheel with a new one.
- 2) Clearances (sensor gaps) should be measured one by one to ensure tone wheel and speed sensor are installed correctly.

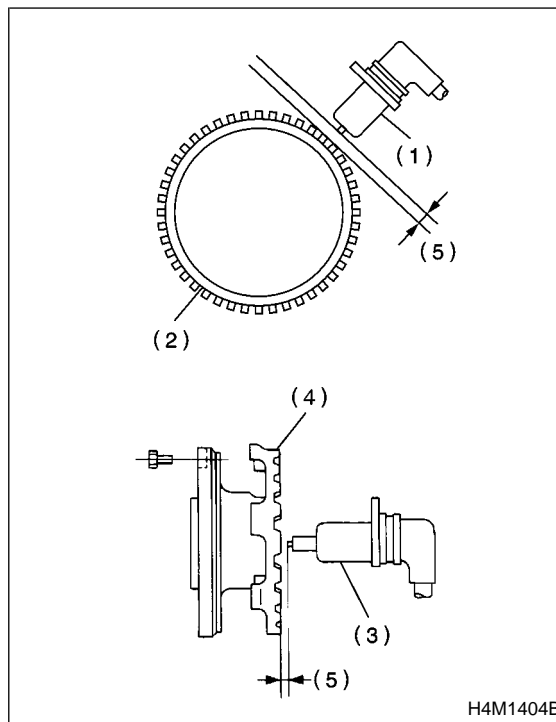

- (1) Front ABS sensor
- (2) Front tone wheel
- (3) Rear ABS sensor
- (4) Rear tone wheel
- (5) Sensor gap

**ABS sensor clearance:**

**Front**

0.3 — 0.8 mm (0.012 — 0.031 in)

**Rear**

0.7 — 1.2 mm (0.028 — 0.047 in)

**NOTE:**

- If clearance is narrow, adjust by using spacer (Part No. 26755AA000).
- If clearance is wide, check the outputted voltage then replace ABS sensor or tone wheel if the outputted voltage is outside the specification.



### 3. OUTPUT VOLTAGE

Output voltage can be checked by the following method. Install resistor and condenser, then rotate wheel about 2.75 km/h (2 MPH) or equivalent.

**NOTE:**

Regarding terminal No., please refer to item 1. ABS SENSOR.

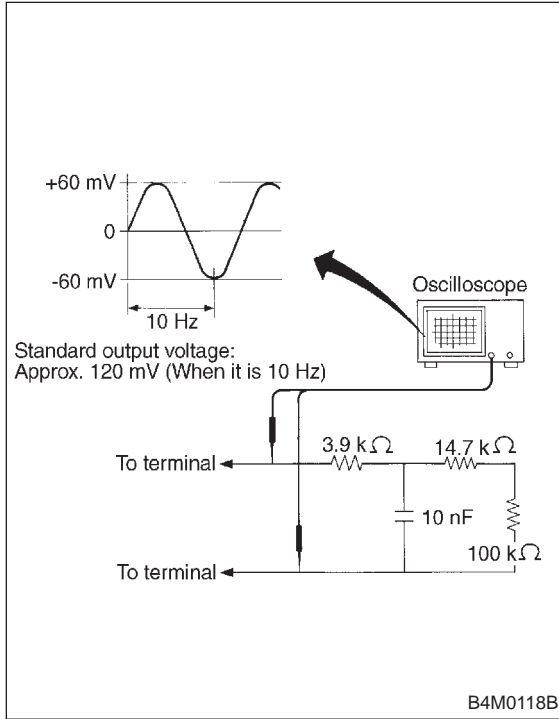

## C: INSTALLATION

### 1. FRONT ABS SENSOR

1) Temporarily install front ABS sensor on housing.

**CAUTION:**

Be careful not to strike ABS sensor's pole piece and tone wheel's teeth against adjacent metal parts during installation.

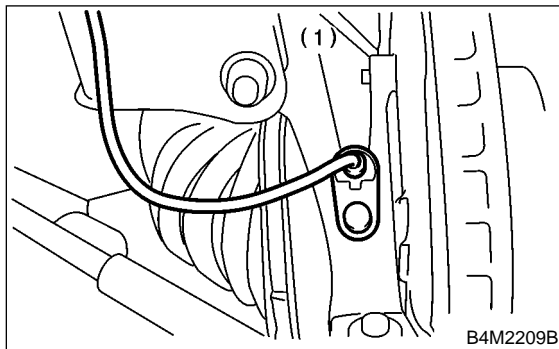

(1) Front ABS sensor

2) Install front drive shaft to hub spline. <Ref. to 4-2 [W1E0].>

3) Install front ABS sensor on strut and wheel apron bracket.

**Tightening torque:**

**32±10 N·m (3.3±1.0 kg·m, 24±7 ft·lb)**

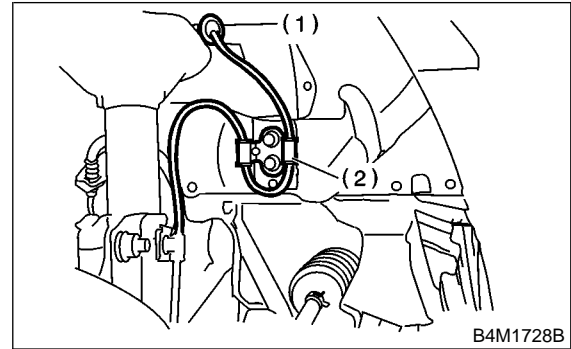

(1) To front ABS sensor connector  
(2) Bracket

4) Install ABS sensor on housing.

(1) Measure the distance "A" between ABS sensor surface and sensor pole face.

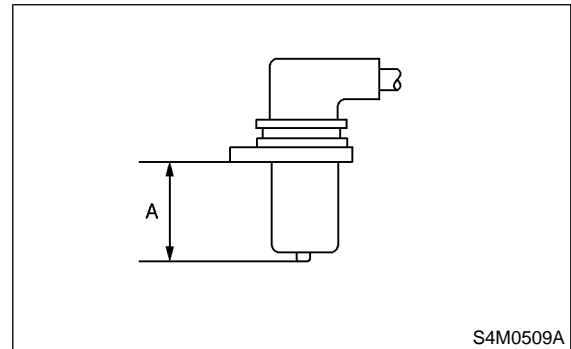

(2) Measure the distance "B" between surface where the front axle housing meets the ABS sensor, and the tone wheel.

**NOTE:**

Measure so that the gauge touches the tone wheel teeth top.

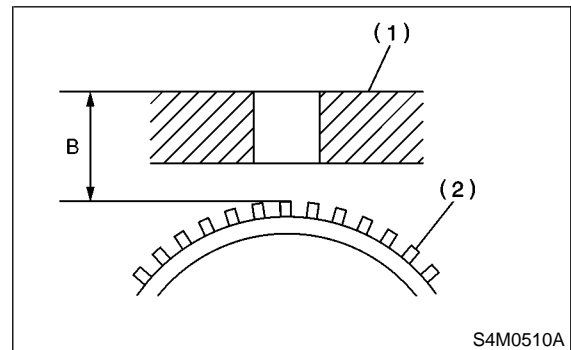

(1) Tone wheel  
(2) Axle housing

(3) Find the gap between the ABS sensor pole face and the surface of the tone wheel teeth by putting the measured values in the formula below and calculating.

**NOTE:**

After standard clearance is obtained over the entire perimeter, tighten ABS sensor on housing to specified torque.

**ABS sensor clearance = B - A**

**ABS sensor standard clearance:**

**0.3 — 0.8 mm (0.012 — 0.031 in)**

**Tightening torque:**

**32±10 N·m (3.3±1.0 kg·m, 24±7 ft·lb)**

**CAUTION:**

**Check the marks on the harness to make sure that no distortion exists. (RH: light blue, LH: brown)**

**NOTE:**

If the clearance is outside specifications, readjust.

**2. REAR ABS SENSOR**

1) Install rear tone wheel on hub, then rear housing on hub. <Ref. to 4-2 [W2D0].>

2) Temporarily install rear ABS sensor on back plate.

**CAUTION:**

**Be careful not to strike ABS sensor's pole piece and tone wheel's teeth against adjacent metal parts during installation.**

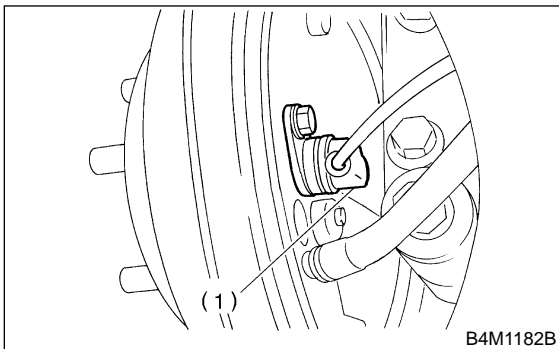

(1) Rear ABS sensor

3) Install rear drive shaft to rear housing and rear differential spindle. <Ref. to 4-2 [W2E0].>

4) Install rear sensor harness on rear trailing link.

**Tightening torque:**

**32±10 N·m (3.3±1.0 kg·m, 24±7 ft·lb)**

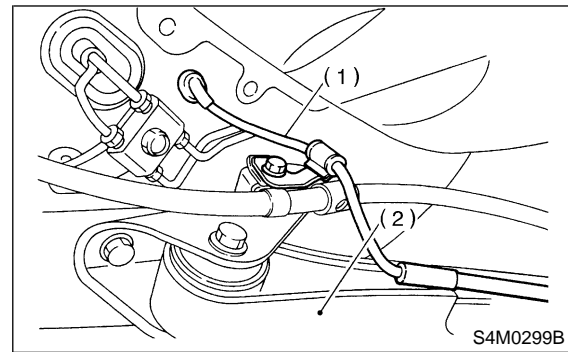

(1) Rear sensor harness  
 (2) Trailing link

5) Place a thickness gauge between ABS sensor's pole piece and tone wheel's tooth face. After standard clearance is obtained over the entire perimeter, tighten ABS sensor on back plate to specified torque.

**ABS sensor standard clearance:**

**0.7 — 1.2 mm (0.028 — 0.047 in)**

**Tightening torque:**

**32±10 N·m (3.3±1.0 kg·m, 24±7 ft·lb)**

**CAUTION:**

**Check the marks on the harness to make sure that no distortion exists. (RH: Pink, LH: Blue)**

**NOTE:**

If the clearance is outside specifications, readjust.

# 14. ABS Control Module and Hydraulic Control Unit (ABSCM&H/U)

## A: REMOVAL

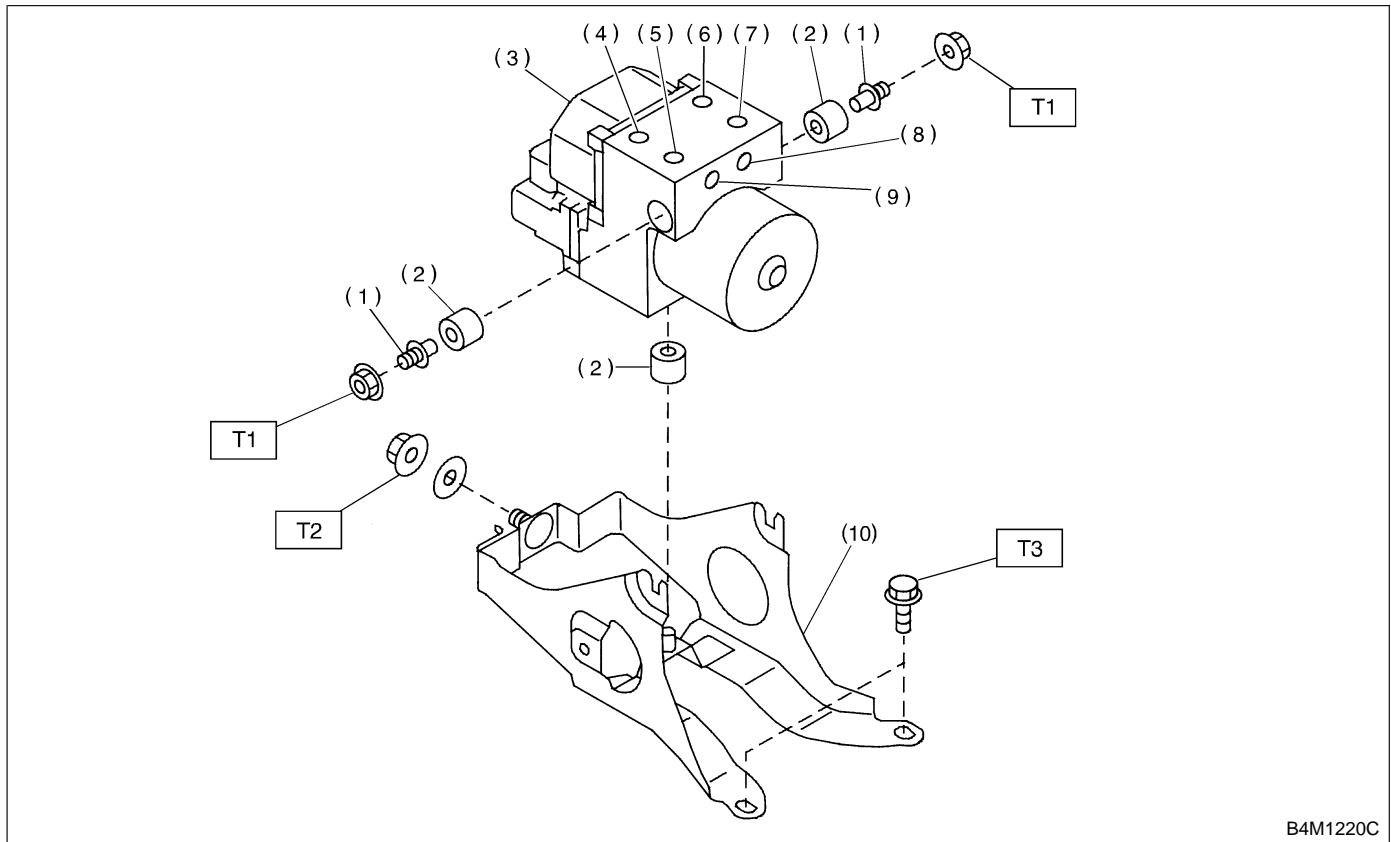

B4M1220C

- |   |                     |
|---|---------------------|
| (1) Stud bolt                                     | (6) Front-RH outlet |
| (2) Damper  | (7) Primary inlet   |
| (3) ABS control module and hydraulic control unit | (8) Rear-LH outlet  |
| (4) Front-LH outlet                               | (9) Rear-RH outlet  |
| (5) Secondary inlet                               | (10) Bracket        |

**Tightening torque: N·m (kg·m, ft·lb)**

**T1: 18±5 (1.8±0.5, 13.0±3.6)**

**T2: 29±7 (3.0±0.7, 21.7±5.1)**

**T3: 32±10 (3.3±1.0, 24±7)**

- 1) Disconnect ground cable from battery.
- 2) Remove air intake duct from engine compartment to facilitate removal of ABSCM&H/U.
- 3) Use an air gun to get rid of water around the ABSCM&H/U.

**CAUTION:**  
The contact will be insufficient if the terminal gets wet.

- 4) Pull on the lock of the ABSCM&H/U connector to remove it.

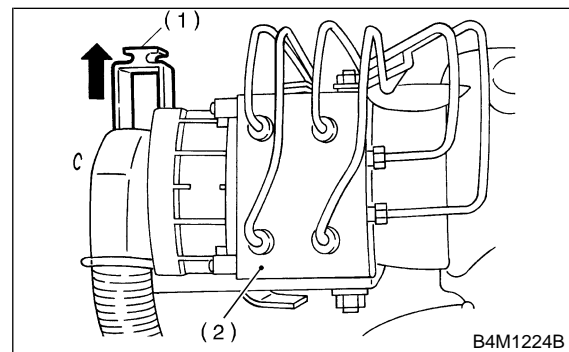

B4M1224B

- (1) Lock
- (2) ABSCM&H/U

- 5) Disconnect connector from ABSCM&H/U.

**CAUTION:**

Be careful not to let water or other foreign matter contact the ABSCM&H/U terminal.

- 6) Unlock cable clip.
- 7) Disconnect brake pipes from ABSCM&H/U.

**CAUTION:**

Wrap brake pipes with vinyl bag to avoid spilling brake fluid on vehicle body.

- 8) Remove ABSCM&H/U from engine compartment.

**CAUTION:**

- ABSCM&H/U cannot be disassembled. Do not attempt to loosen bolts and nuts.
- Do not drop or bump ABSCM&H/U.
- Do not turn the ABSCM&H/U upside down or place it on its side.
- Be careful to prevent foreign particles from getting into ABSCM&H/U.
- Apply a coat of rust-preventive wax (Nippeco LT or GB) to bracket attaching bolt after tightening.
- Do not pull harness disconnecting harness connector.

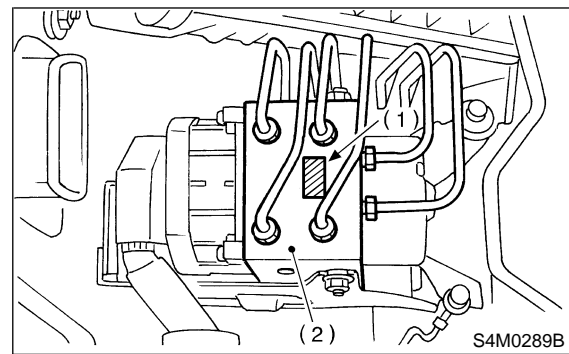

- (1) Mark
- (2) ABSCM&H/U

**C: CHECKING THE HYDRAULIC UNIT ABS OPERATION**

**1. CHECKING THE HYDRAULIC UNIT ABS OPERATION BY PRESSURE GAUGE**

- 1) Lift-up vehicle and remove wheels.
- 2) Disconnect the air bleeder screws from the FL and FR caliper bodies.
- 3) Connect the two pressure gauges to the FL and FR caliper bodies.

**CAUTION:**

- Pressure gauges used exclusively for brake fluid must be used.
- Do not employ pressure gauge previously used for transmission since the piston seal is expanded which may lead to malfunction of the brake.

**NOTE:**

Wrap sealing tape around the pressure gauge.

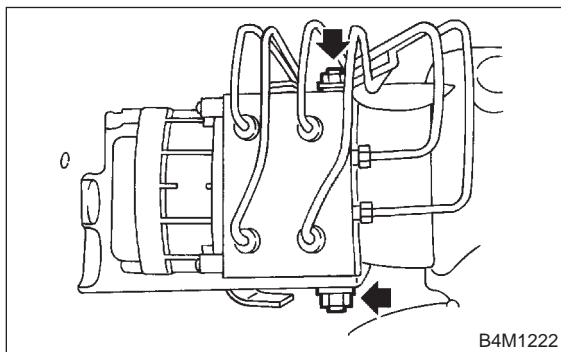

**B: INSPECTION**

- 1) Check connected and fixed condition of connector.
- 2) Check specifications of the mark with ABSCM&H/U.

Mark	Model
C7	AWD AT
C8	AWD MT

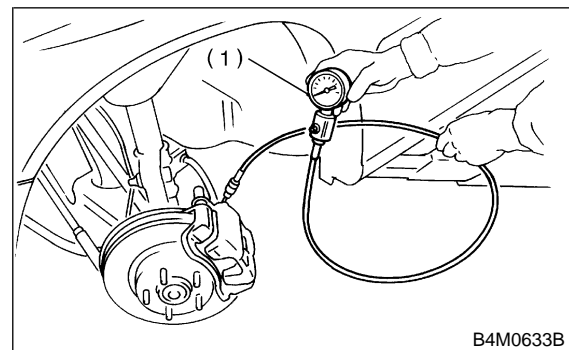

- (1) Pressure gauge

- 4) Bleed air from the pressure gauges.
- 5) Perform ABS sequence control.  
<Ref. to 4-4 [W14D0].>
- 6) When the hydraulic unit begins to work, first the FL side performs decompression, holding, and compressing; and then the FR side performs decompression, holding, and compressing.
- 7) Read values indicated on the pressure gauge and check if the fluctuation of the values between

decompression and compression meets the standard values. Also check if any irregular brake pedal tightness is felt.

	Front wheel	Rear wheel
Initial value	3,432 kPa (35 kg/cm <sup>2</sup> , 498 psi)	3,432 kPa (35 kg/cm <sup>2</sup> , 498 psi)
When decompressed	490 kPa (5 kg/cm <sup>2</sup> , 71 psi) or less	490 kPa (5 kg/cm <sup>2</sup> , 71 psi) or less
When compressed	3,432 kPa (35 kg/cm <sup>2</sup> , 498 psi) or more	3,432 kPa (35 kg/cm <sup>2</sup> , 498 psi) or more

- 8) Remove pressure gauges from FL and FR caliper bodies.
- 9) Remove air bleeder screws from the RL and RR caliper bodies.
- 10) Connect the air bleeder screws to the FL and FR caliper bodies.
- 11) Connect the two pressure gauges to the RL and RR caliper bodies.
- 12) Bleed air from the pressure gauges and the FL and FR caliper bodies.
- 13) Perform ABS sequence control.  
<Ref. to 4-4 [W14D0].>
- 14) When the hydraulic unit begins to work, first the RR side performs decompression, holding, and compressing; and then the RL side performs decompression, holding, and compressing.
- 15) Read values indicated on the pressure gauges and check if they meet the standard value.
- 16) After checking, remove the pressure gauges from caliper bodies.
- 17) Connect the air bleeder screws to RL and RR caliper bodies.
- 18) Bleed air from brake line.

**2. CHECKING THE HYDRAULIC UNIT ABS OPERATION WITH BRAKE TESTER**

- 1) In the case of AWD AT vehicles, install a spare fuse with the FWD connector in the main fuse box to simulate FWD vehicles.

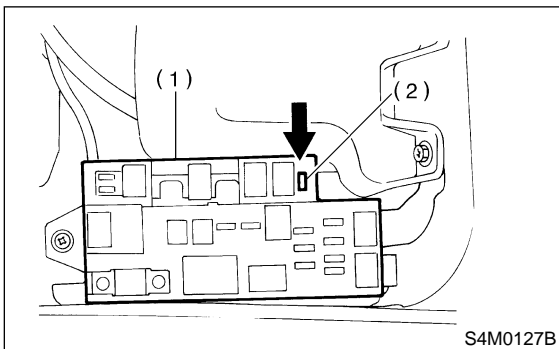

- (1) Main fuse box
- (2) FWD connector

- 2) Prepare for operating ABS sequence control.

- <Ref. to 4-4 [W14D1].> or <Ref. to 4-4 [W14D2].>
- 3) Set the front wheels or rear wheels on the brake tester and set the select lever's position at "neutral".

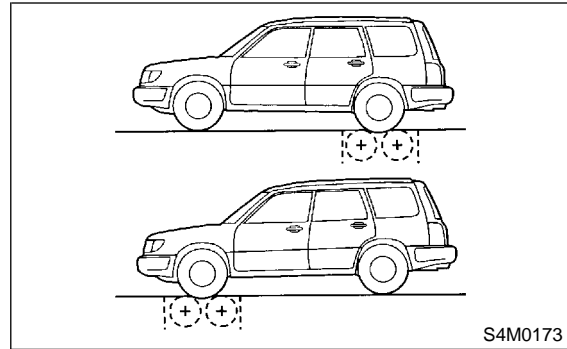

- 4) Operate the brake tester.
- 5) Perform ABS sequence control. <Ref. to 4-4 [W14D1].> or <Ref. to 4-4 [W14D2].>
- 6) Hydraulic unit begins to work; and check the following working sequence.
  - (1) The FL wheel performs decompression, holding, and compression in sequence, and subsequently the FR wheel repeats the cycle.
  - (2) The RR wheel performs decompression, holding, and compression in sequence, and subsequently the RL wheel repeats the cycle.
- 7) Read values indicated on the brake tester and check if the fluctuation of values, when decompressed and compressed, meet the standard values.

	Front wheel	Rear wheel
Initial value	981 N (100 kg, 221 lb)	981 N (100 kg, 221 lb)
When decompressed	490 N (50 kg, 110 lb) or less	490 N (50 kg, 110 lb) or less
When compressed	981 N (100 kg, 221 lb) or more	981 N (100 kg, 221 lb) or more

- 8) After checking, also check if any irregular brake pedal tightness is felt.

## D: ABS SEQUENCE CONTROL

- 1) Under the ABS sequence control, after the hydraulic unit solenoid valve is driven, the operation of the hydraulic unit can be checked by means of the brake tester or pressure gauge.
- 2) ABS sequence control can be started by diagnosis connector or select monitor.

### 1. OPERATIONAL GUIDELINES OF THE ABS SEQUENCE CONTROL WITH DIAGNOSIS CONNECTOR

- 1) Connect diagnosis terminals to terminals No. 3 and No. 6 of the diagnosis connector beside driver's seat heater unit.

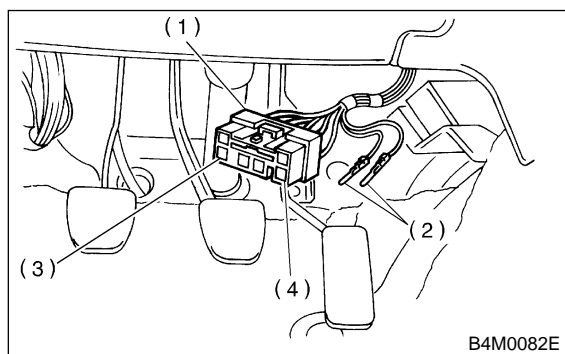

- (1) Diagnosis connector
- (2) Diagnosis terminals
- (3) 3 terminal
- (4) 6 terminal

- 2) Set the speed of all wheels at 4 km/h (2 MPH) or less.
- 3) Turn ignition switch to OFF.
- 4) Within 0.5 seconds after the ABS warning light goes out, depress the brake pedal and hold it immediately after ignition switch is turned to ON.

#### CAUTION:

**Do not depress the clutch pedal.**

#### NOTE:

- When the ignition switch is set to on, the brake pedal must not be depressed.
  - Engine must not operate.
- 5) After completion of ABS sequence control, turn ignition switch to OFF.

### 2. OPERATIONAL GUIDELINES OF THE ABS SEQUENCE CONTROL WITH SELECT MONITOR

#### NOTE:

- In the event of any trouble, the sequence control may not be operative. In such a case, activate the sequence control, referring to "OPERATIONAL GUIDELINES OF THE ABS SEQUENCE CON-

TROL WITH DIAGNOSIS CONNECTOR". <Ref. to 4-4 [W14D1].>

- When the diagnosis terminal is connected to the diagnosis connector, the sequence control will not operate.

- 1) Connect select monitor to data link connector beside driver's seat instrument panel lower cover.
- 2) Turn ignition switch to ON.
- 3) Turn select monitor switch to ON.
- 4) Put select monitor to {ABS/TCS} mode.
- 5) When {Function check sequence} is selected, 'ABS sequence control' will start.
- 6) The message 'Press Brake Pedal Firmly' is displayed as follows:

- (1) When using the brake tester, depress brake pedal with braking force of 981 N (100 kg, 221 lb).
- (2) When using the pressure gauge, depress brake pedal so as to make the pressure gauge indicate 3,432 kPa (35 kg/cm<sup>2</sup>, 498 psi).

#### CAUTION:

**Do not depress the clutch pedal.**

- 7) When the message "Press YES" is displayed, press YES key.
- 8) Operation points will be displayed on select monitor.

### 3. CONDITIONS FOR COMPLETION OF ABS SEQUENCE CONTROL

When the following conditions develop, the ABS sequence control stops and ABS operation is returned to the normal control mode.

- 1) When the speed of at least one wheel reaches 10 km/h (6 MPH).
- 2) When terminal No. 3 or No. 6 are separated from diagnosis terminals. (When select monitor is not used.)
- 3) When the brake pedal is released during sequence control and the braking lamp switch is set to off.
- 4) When brake pedal is depressed after ignition key is turned to ON, and before ABS warning light goes out. (When select monitor is not used.)
- 5) When brake pedal is not depressed after ignition key is turned to ON, and within 0.5 seconds after ABS warning light goes out. (When select monitor is not used.)
- 6) After completion of the sequence control.
- 7) When malfunction is detected. (When select monitor is used.)

**4. CONDITIONS FOR ABS SEQUENCE CONTROL**

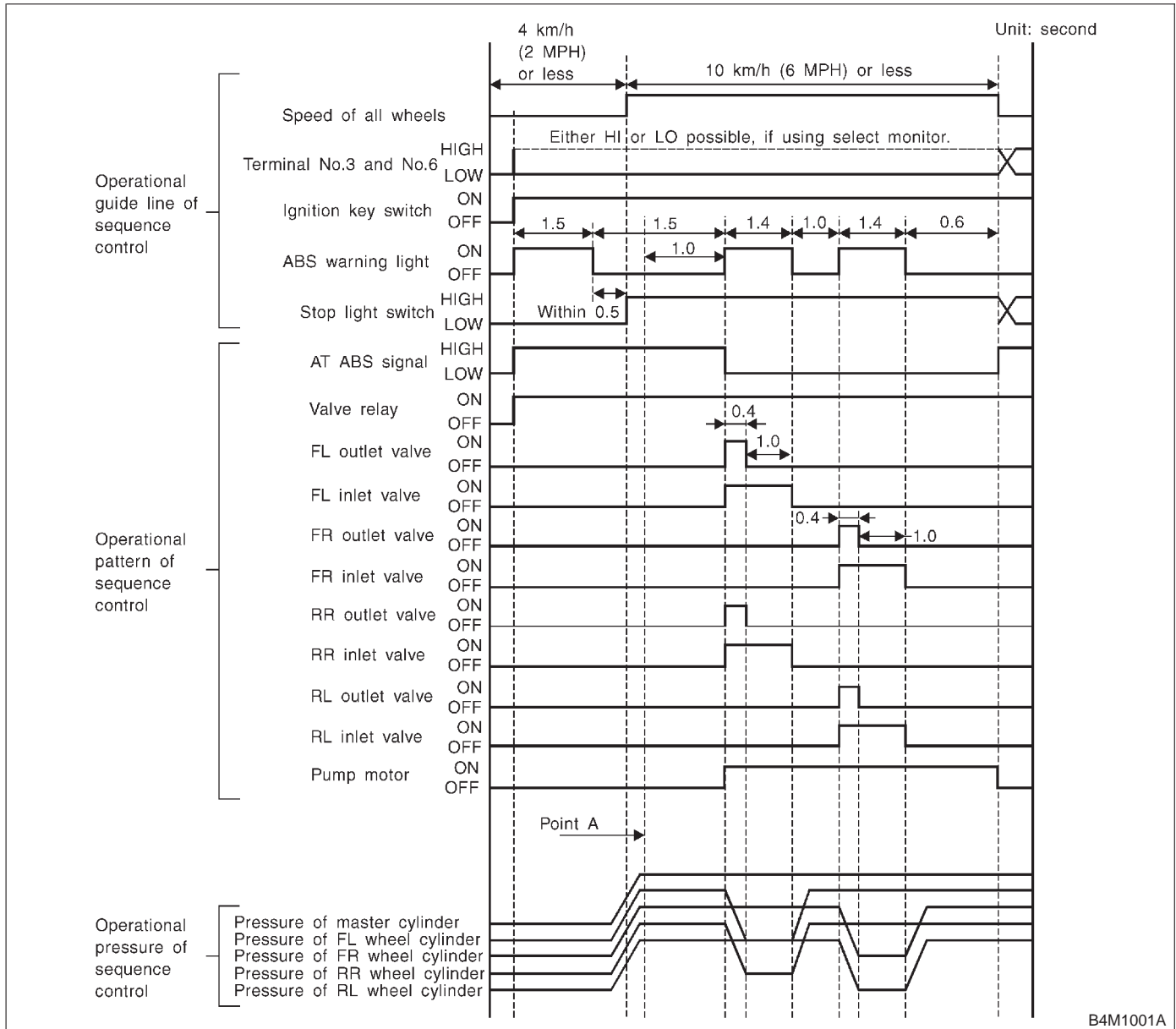

**NOTE:**

- When select monitor is used, control operation starts at point A. The patterns from IGN key ON to the point A show that operation is started by diagnosis connector.
- HIGH means high voltage.
- LOW means low voltage.

**E: INSTALLATION**

1) Install ABSCM&H/U.

**CAUTION:**

Confirm that the specifications of the ABSCM&H/U conforms to the vehicle specifications.

**Tightening torque:**

**18±5 N·m (1.8±0.5 kg·m, 13.0±3.6 ft·lb)**

2) Install ABSCM&H/U ground terminal to bracket.

**Tightening torque:**

**32±10 N·m (3.3±1.0 kg·m, 24±7 ft·lb)**

3) Connect brake pipes to their correct ABSCM&H/U connections. <Ref. to 4-4 [W16B0].>

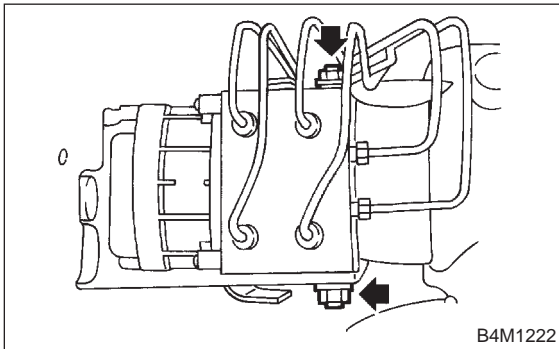

4) Using cable clip, secure ABSCM&H/U harness to bracket.

5) Connect connector to ABSCM&H/U.

**CAUTION:**

- Be sure to remove all foreign matter from inside the connector before connecting.
- Ensure that the ABSCM&H/U connector is securely locked.

6) Install air intake duct.

7) Connect ground cable to battery.

8) Bleed air from the brake system.

**15. G Sensor**

**A: REMOVAL AND INSTALLATION**

- 1) Turn ignition switch to OFF.
- 2) Remove console cover. <Ref. to 5-4 [W1A0].>
- 3) Disconnect connector from G sensor.
- 4) Remove G sensor from body.

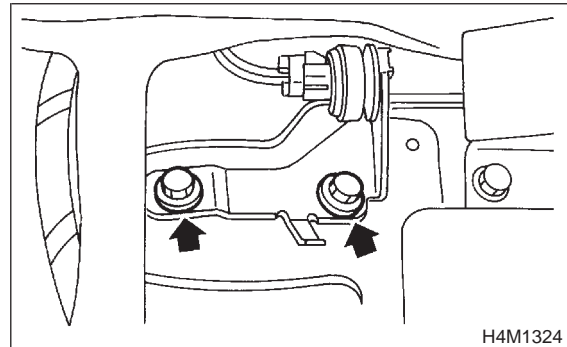

5) Install in the reverse order of removal.

**CAUTION:**

Do not drop or bump G sensor.

**B: INSPECTION WITH CIRCUIT TESTER**

**15B1 : CHECK G SENSOR.**

- 1) Turn ignition switch to OFF.
- 2) Remove G sensor from vehicle.
- 3) Connect connector to G sensor.
- 4) Turn ignition switch to ON.
- 5) Measure voltage between G sensor connector terminals.

**Connector & terminal**

**(P9) No. 2 (+) — No. 3 (-)**

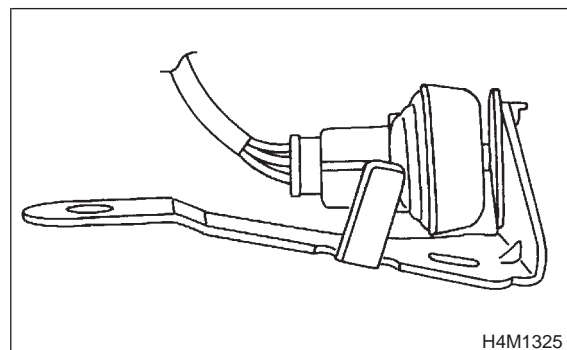

**CHECK** : Is the voltage 2.3±0.2 V when G sensor is horizontal?

**YES** : Go to step 15B2.

**NO** : Replace G sensor.



**E: INSTALLATION**

1) Install ABSCM&H/U.

**CAUTION:**

Confirm that the specifications of the ABSCM&H/U conforms to the vehicle specifications.

**Tightening torque:**

**18±5 N·m (1.8±0.5 kg·m, 13.0±3.6 ft·lb)**

2) Install ABSCM&H/U ground terminal to bracket.

**Tightening torque:**

**32±10 N·m (3.3±1.0 kg·m, 24±7 ft·lb)**

3) Connect brake pipes to their correct ABSCM&H/U connections. <Ref. to 4-4 [W16B0].>

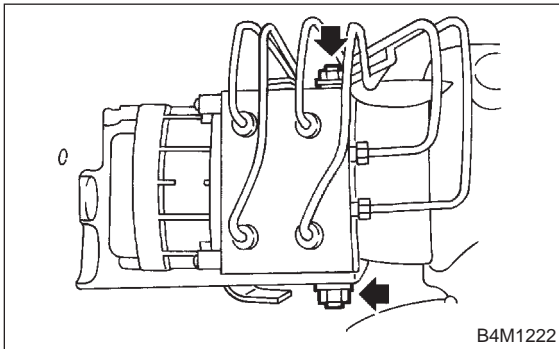

4) Using cable clip, secure ABSCM&H/U harness to bracket.

5) Connect connector to ABSCM&H/U.

**CAUTION:**

- Be sure to remove all foreign matter from inside the connector before connecting.
- Ensure that the ABSCM&H/U connector is securely locked.

6) Install air intake duct.

7) Connect ground cable to battery.

8) Bleed air from the brake system.

**15. G Sensor**

**A: REMOVAL AND INSTALLATION**

- 1) Turn ignition switch to OFF.
- 2) Remove console cover. <Ref. to 5-4 [W1A0].>
- 3) Disconnect connector from G sensor.
- 4) Remove G sensor from body.

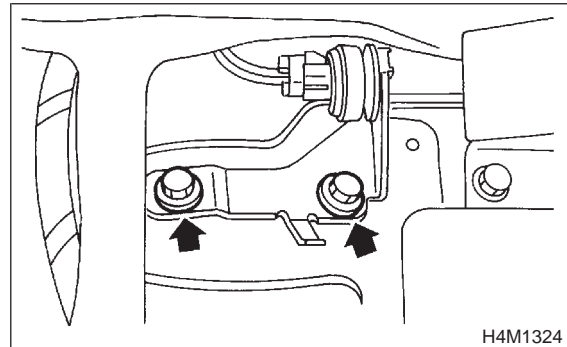

5) Install in the reverse order of removal.

**CAUTION:**

Do not drop or bump G sensor.

**B: INSPECTION WITH CIRCUIT TESTER**

**15B1 : CHECK G SENSOR.**

- 1) Turn ignition switch to OFF.
- 2) Remove G sensor from vehicle.
- 3) Connect connector to G sensor.
- 4) Turn ignition switch to ON.
- 5) Measure voltage between G sensor connector terminals.

**Connector & terminal**

**(P9) No. 2 (+) — No. 3 (-)**

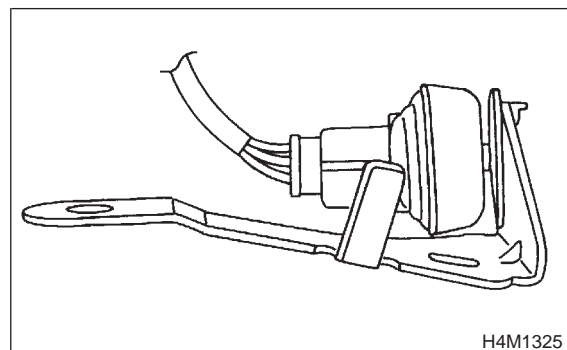

**CHECK** : Is the voltage 2.3±0.2 V when G sensor is horizontal?

**YES** : Go to step 15B2.

**NO** : Replace G sensor.

**15B2 : CHECK G SENSOR.**

Measure voltage between G sensor connector terminals.

**Connector & terminal**

**(P9) No. 2 (+) — No. 3 (-)**

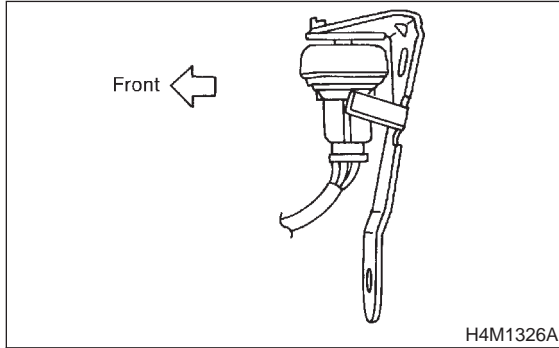

**CHECK** : *Is the voltage  $3.9\pm 0.2$  V when G sensor is inclined forwards to  $90^\circ$ ?*

**YES** : Go to step 15B3.

**NO** : Replace G sensor.

**15B3 : CHECK G SENSOR.**

Measure voltage between G sensor connector terminals.

**Connector & terminal**

**(P9) No. 2 (+) — No. 3 (-)**

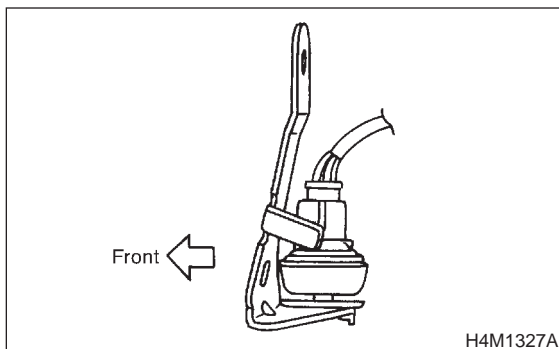

**CHECK** : *Is the voltage  $0.7\pm 0.2$  V when G sensor is inclined backwards to  $90^\circ$ ?*

**YES** : G sensor is normal.

**NO** : Replace G sensor.

**C: INSPECTION WITH SELECT MONITOR****15C1 : CHECK G SENSOR.**

- 1) Turn ignition switch to OFF.
- 2) Connect select monitor connector to data link connector.
- 3) Turn select monitor into {ABS/TCS} mode.
- 4) Set the display in the {Current Data Display & Save} mode.
- 5) Read the G sensor output voltage.

**CHECK** : *Is the indicated reading  $2.3\pm 0.2$  V when the vehicle is in horizontal position?*

**YES** : Go to step 15C2.

**NO** : Replace G sensor.

**15C2 : CHECK G SENSOR.**

- 1) Remove console box.
- 2) Remove G sensor from vehicle. (Do not disconnect connector.)
- 3) Read the select monitor display.

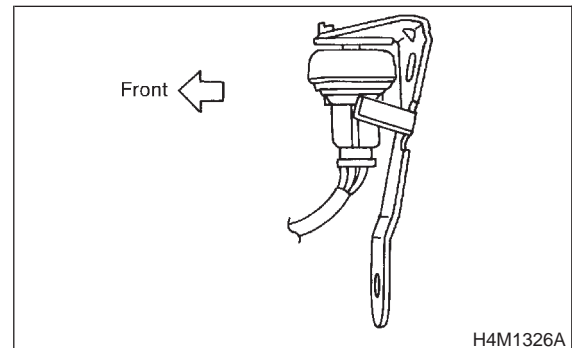

**CHECK** : *Is the indicated reading  $3.9\pm 0.2$  V when G sensor is inclined forwards to  $90^\circ$ ?*

**YES** : Go to step 15C3.

**NO** : Replace G sensor.

**15C3 : CHECK G SENSOR.**

Read the select monitor display.

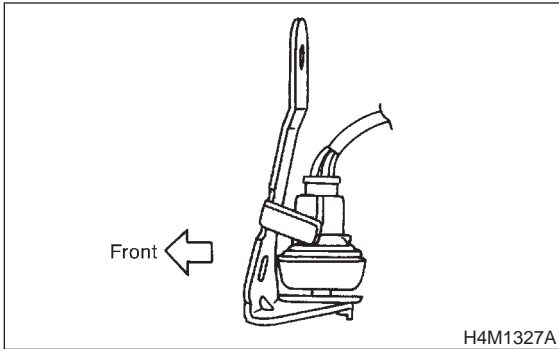

**CHECK** : *Is the indicated reading  $0.7 \pm 0.2$  V when G sensor is inclined backwards to  $90^\circ$ ?*

**YES** : G sensor is normal.

**NO** : Replace G sensor.

**16. Brake Pipe AIRBAG****A: SUPPLEMENTAL RESTRAINT SYSTEM "AIRBAG"**

Airbag system wiring harness is routed near the center brake pipe.

**CAUTION:**

- All airbag system wiring harness and connectors are yellow. Do not use electrical test equipment on these circuit.
- Be careful not to damage airbag system wiring harness when servicing the center brake pipe.

**B: REMOVAL AND INSTALLATION****CAUTION:**

- When removing and installing the brake pipe, make sure that it is not bent.
- After installing the brake pipe and hose, bleed the air.
- After installing the brake hose, make sure that it does not touch the tire or suspension assembly, etc.

**Brake pipe tightening torque:**

$15^{+3}/_{-2}$  N·m ( $1.5^{+0.3}/_{-0.2}$  kg·m,  $10.8^{+2.2}/_{-1.4}$  ft·lb)

**15C3 : CHECK G SENSOR.**

Read the select monitor display.

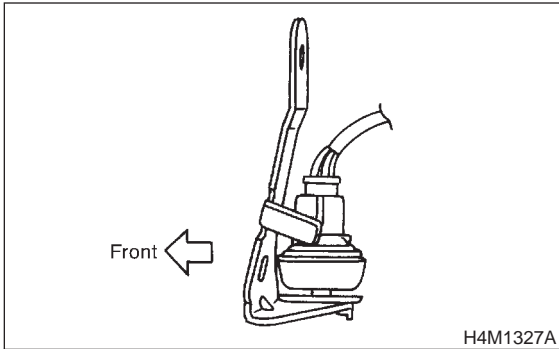

**CHECK** : *Is the indicated reading  $0.7 \pm 0.2$  V when G sensor is inclined backwards to  $90^\circ$ ?*

**YES** : G sensor is normal.

**NO** : Replace G sensor.

**16. Brake Pipe AIRBAG****A: SUPPLEMENTAL RESTRAINT SYSTEM "AIRBAG"**

Airbag system wiring harness is routed near the center brake pipe.

**CAUTION:**

- All airbag system wiring harness and connectors are yellow. Do not use electrical test equipment on these circuit.
- Be careful not to damage airbag system wiring harness when servicing the center brake pipe.

**B: REMOVAL AND INSTALLATION****CAUTION:**

- When removing and installing the brake pipe, make sure that it is not bent.
- After installing the brake pipe and hose, bleed the air.
- After installing the brake hose, make sure that it does not touch the tire or suspension assembly, etc.

**Brake pipe tightening torque:**

$15^{+3}/_{-2}$  N·m ( $1.5^{+0.3}/_{-0.2}$  kg·m,  $10.8^{+2.2}/_{-1.4}$  ft·lb)

## 1. Entire Brake System

	Trouble and possible cause	Corrective action
<b>1. Insufficient braking</b>	(1) Fluid leakage from the hydraulic mechanism	Repair or replace (cup, piston seal, piston boot, master cylinder piston kit, pipe or hose).
	(2) Entry of air into the hydraulic mechanism	Bleed the air.
	(3) Excessively wide shoe clearance	Adjust the clearance.
	(4) Wear, deteriorated surface material, adhering water or fluid on the lining	Replace, grind or clean.
	(5) Improper operation of master cylinder, disc caliper, brake booster or check valve	Correct or replace.
<b>2. Unstable or uneven braking</b>	(1) Fluid on the lining, drum or rotor	Eliminate cause of fluid leakage, clean, or replace.
	(2) Drum or rotor eccentricity	Correct or replace the drum or rotor.
	(3) Worn brake drum, or damage to the drum caused by sand	Correct by grinding, or replace.
	(4) Improper lining contact, deteriorated surface material, improper inferior material, or wear	Correct by grinding, or replace.
	(5) Deformed back plate	Correct or replace.
	(6) Improper tire inflation	Inflate to correct pressure.
	(7) Disordered wheel alignment	Adjust alignment.
	(8) Loosened back plate or the support installing bolts	Retighten.
	(9) Loosened wheel bearing	Retighten to normal tightening torque or replace.
	(10) Trouble in the hydraulic system	Replace the cylinder, brake pipe or hose.
	(11) Uneven effect of the parking brake	Check, adjust, or replace the rear brake and cable system.
<b>3. Excessive pedal stroke</b>	(1) Entry of air into the hydraulic mechanism	Bleed the air.
	(2) Excessive play in the master cylinder push rod	Adjust.
	(3) Fluid leakage from the hydraulic mechanism	Repair or replace (cup, piston seal, piston boot, master cylinder piston kit, pipe or hose).
	(4) Improperly adjusted shoe clearance	Adjust.
	(5) Improper lining contact or worn lining	Correct or replace.
<b>4. Brake dragging or improper brake return</b>	(1) Insufficient pedal play	Adjust play.
	(2) Improper master cylinder return	Clean or replace the cylinder.
	(3) Clogged hydraulic system	Replace.
	(4) Improper return or adjustment of parking brake	Correct or adjust.
	(5) Weakened spring tension or breakage of shoe return spring	Replace the spring.
	(6) Excessively narrow shoe clearance	Adjust the clearance.
	(7) Improper disc caliper operation	Correct or replace.
	(8) Improper adjusted wheel bearing	Adjust or replace.
<b>5. Brake noise (1) (creak sound)</b>	(1) Hardened or deteriorated lining	Replace the shoe assembly or pad.
	(2) Worn lining	Replace the shoe assembly or pad.
	(3) Loosened back plate or the support installing bolts	Retighten.
	(4) Loose wheel bearing	Retighten to normal tightening torque.
	(5) Dirty drum or rotor	Clean the drum or rotor, or clean and replace the brake assembly.
<b>6. Brake noise (2) (hissing sound)</b>	(1) Worn lining	Replace the shoe assembly or pad.
	(2) Improper installed shoe or pad	Correct or replace the shoe assembly or pad.
	(3) Loose or bent drum or rotor	Retighten or replace.

	Trouble and possible cause	Corrective action
<b>7. Brake noise (3) (click sound)</b>	In the case of the disc brake:	
	(1) Excessively worn pad or the support	Replace the pad or the support.
	In the case of the drum brake:	
	(1) Excessively worn shoe ridge	Replace the back plate.
	(2) Lack of oil on the shoe ridge surface and anchor	Add more grease.

MEMO:

## 1. Pedal System

Brake pedal	Free play		1 — 3 mm (0.04 — 0.12 in) [Depress brake pedal pad with a force of less than 10 N (1 kg, 2 lb).]
Clutch pedal	Free play	At clutch pedal pad	4 — 13 mm (0.16 — 0.51 in)
	Full stroke	At clutch pedal pad	130 — 135 mm (5.11 — 5.31 in)
Accelerator pedal	Free play	At pedal pad	1 — 4 mm (0.04 — 0.16 in)
	Stroke	At pedal pad	50 — 55 mm (1.97 — 2.17 in)



1. Pedal

A: MT MODEL

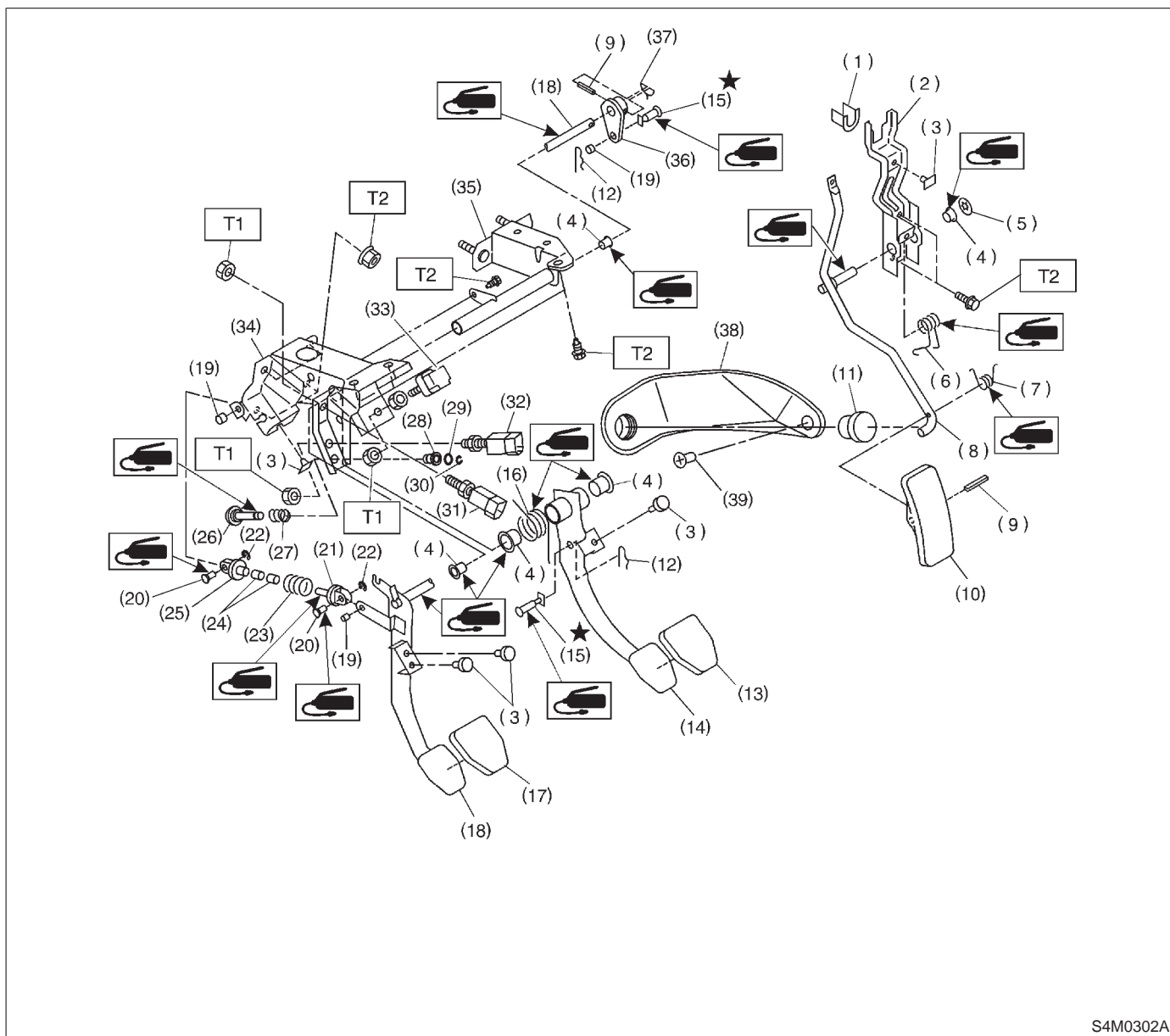

S4M0302A

- |                              |                         |  |
|------------------------------|-------------------------|--|
| (1) Holder                   | (16) Brake pedal spring | (31) Clutch switch (Starter interlock)   |
| (2) Accelerator bracket      | (17) Clutch pedal pad   | (32) Clutch switch (With cruise control) |
| (3) Stopper                  | (18) Clutch pedal       | (33) Stop light switch                   |
| (4) Bushing                  | (19) Bushing C          | (34) Pedal bracket                       |
| (5) Clip                     | (20) Clutch clevis pin  | (35) Clutch master cylinder bracket      |
| (6) Accelerator spring       | (21) Assist rod A       | (36) Lever                               |
| (7) Accelerator pedal spring | (22) Clip               | (37) Lock wire                           |
| (8) Accelerator pedal        | (23) Assist spring      | (38) Accelerator plate                   |
| (9) Spring pin               | (24) Assist bushing     | (39) Clip                                |
| (10) Accelerator pedal pad   | (25) Assist rod B       |  |
| (11) Accelerator stopper     | (26) Rod S              |  |
| (12) Snap pin                | (27) Spring S           |  |
| (13) Brake pedal pad         | (28) Bushing S          |  |
| (14) Brake pedal             | (29) O-ring             |  |
| (15) Clevis pin              | (30) Clip               |  |

**Tightening torque: N·m (kg·m, ft·lb)**

**T1: 8±2 (0.8±0.2, 5.8±1.4)**

**T2: 18±5 (1.8±0.5, 13.0±3.6)**

B: AT MODEL

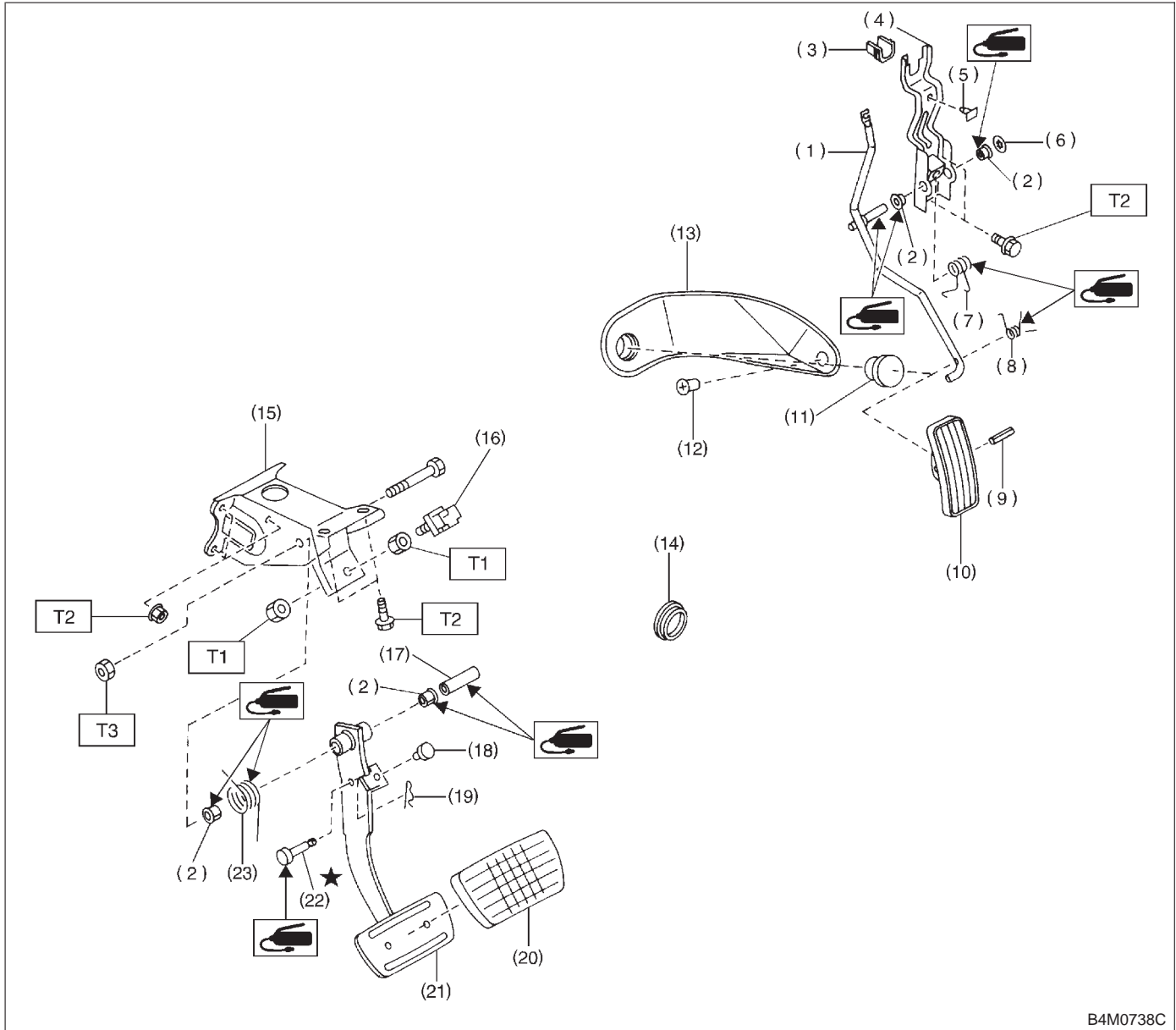

B4M0738C

- |                              |                          |                         |
|------------------------------|--------------------------|-------------------------|
| (1) Accelerator pedal        | (11) Accelerator stopper | (21) Brake pedal        |
| (2) Bushing                  | (12) Clip                | (22) Clevis pin         |
| (3) Holder                   | (13) Accelerator plate   | (23) Brake pedal spring |
| (4) Accelerator bracket      | (14) Plug                |                         |
| (5) Stopper                  | (15) Pedal bracket       |                         |
| (6) Clip                     | (16) Stop light switch   |                         |
| (7) Accelerator spring       | (17) Spacer              |                         |
| (8) Accelerator pedal spring | (18) Stopper             |                         |
| (9) Spring pin               | (19) Snap pin            |                         |
| (10) Accelerator pedal pad   | (20) Brake pedal pad     |                         |

**Tightening torque: N·m (kg·m, ft·lb)**

**T1: 8±2 (0.8±0.2, 5.8±1.4)**

**T2: 18±5 (1.8±0.5, 13.0±3.6)**

**T3: 29±7 (3.0±0.7, 21.7±5.1)**

## 1. Pedal

### A: ON-CAR SERVICE

#### 1. BRAKE PEDAL

- 1) Check position of pedal pad.

#### **Pedal height: L**

**148 mm (5.83 in)**

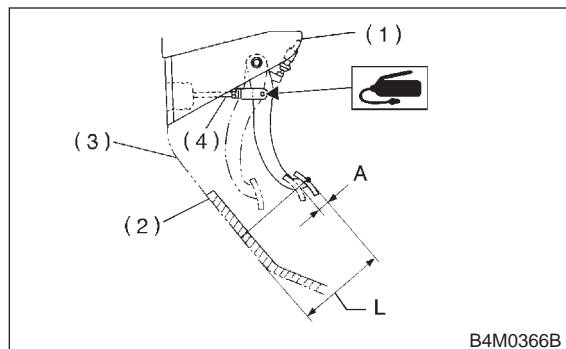

- (1) Stop light switch
- (2) Mat
- (3) Toe board
- (4) Brake booster operating rod

- 2) If it is not in specified value, adjust it by adjusting brake booster operating rod length.

- 3) Check free play by operating pedal by hand. If it is not in specified value, adjust it by adjusting position of stop light switch.

#### **CAUTION:**

**Be careful not to rotate stop light switch.**

#### **Brake pedal free play: A**

**1 — 3 mm (0.04 — 0.12 in) [Depress brake pedal pad with a force of less than 10 N (1 kg, 2 lb).]**

#### **Stop light switch lock nut tightening torque:**

**8±2 N·m (0.8±0.2 kg·m, 5.8±1.4 ft·lb)**

- 4) Apply grease to operating rod connecting pin to prevent it from wearing.

#### 2. CLUTCH PEDAL

- 1) Push release fork until operating cylinder push rod retracts. Check that clutch fluid level in reservoir tank increases.

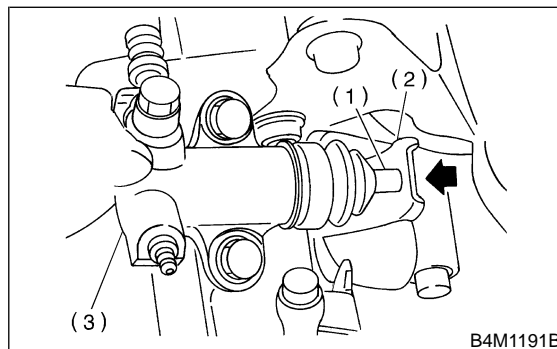

- (1) Push rod
- (2) Release lever
- (3) Operating cylinder

- 2) If clutch fluid level increases, hydraulic clutch play is correct.

- 3) If clutch fluid level does not increase or push rod does not retract, clutch pedal must be adjusted. <Ref. to 4-5 [W1F1].>

- 4) Check the fluid level on the outside of the clutch master cylinder tank. If the level is below "MIN", add clutch fluid to bring it up to "MAX".

#### **Recommended clutch fluid:**

**FMVSS No. 116, fresh DOT 3 or DOT 4 brake fluid**

## 1. Pedal

**3. ACCELERATOR PEDAL**

Check pedal stroke and free play by operating accelerator pedal by hand.

If it is not within specified value, adjust it by turning nut connecting accelerator cable to throttle body.

**Free play at pedal pad: L**

**1 — 4 mm (0.04 — 0.16 in)**

**Stroke at pedal pad: A**

**50 — 55 mm (1.97 — 2.17 in)**

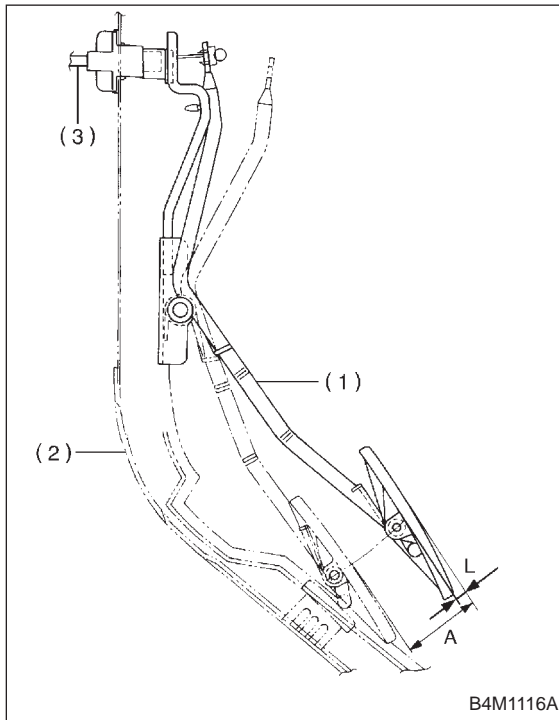

- (1) Accelerator pedal
- (2) Toe board
- (3) Accelerator cable

**Accelerator cable lock nut tightening torque:**  
**14±4 N·m (1.4±0.4 kg·m, 10.1±2.9 ft·lb)**

**B: REMOVAL****1. ACCELERATOR PEDAL**

- 1) Disconnect ground cable from battery.
- 2) Disconnect accelerator cable from throttle body.

**CAUTION:**

**Be careful not to kink accelerator cable.**

- 3) Remove instrument panel lower cover from instrument panel, and connector.
- 4) Disconnect accelerator cable from accelerator pedal lever.

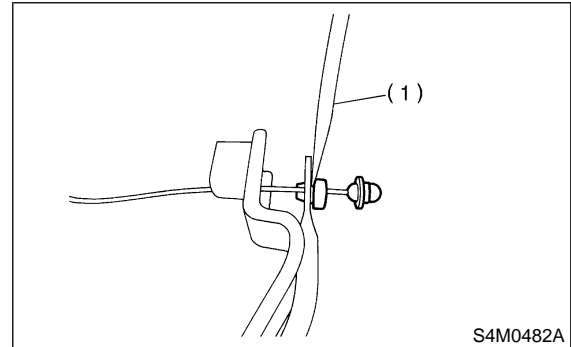

- (1) Slot type screwdriver

- 5) Working inside engine compartment, remove casing cap out of the toe board by turning it clockwise.

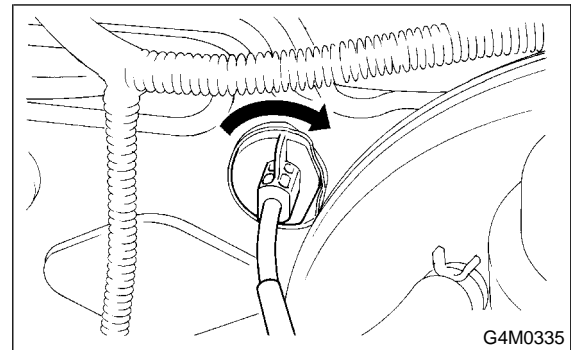

- 6) Pull out the cable from the toe board hole.
- 7) Remove accelerator pedal connecting bolt from accelerator pedal bracket.

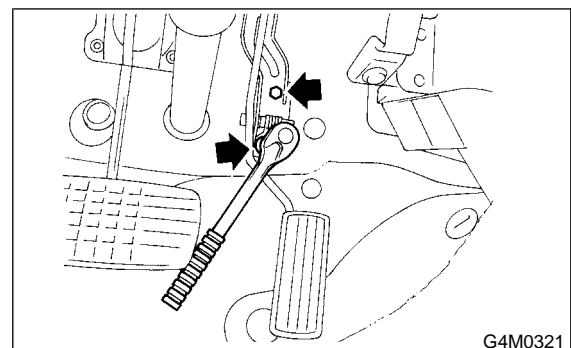

## 2. BRAKE AND CLUTCH PEDAL

- 1) Disconnect ground cable from battery.
- 2) Remove instrument panel lower cover from instrument panel.
- 3) Disconnect the following parts from pedal bracket.
  - Operating rod of brake booster
  - Electrical connectors (for stop light switch, etc.)
- 4) Remove clevis pin which secures lever to push rod.
- 5) Remove nut which secures clutch master cylinder.
- 6) Remove bolts and nuts which secure brake and clutch pedals, and remove pedal assembly.

## 3. BRAKE PEDAL

- 1) Disconnect ground cable from battery.
- 2) Remove instrument panel lower cover from instrument panel.
- 3) Remove clevis pin which secures brake pedal to brake booster operating rod. Also disconnect stop light switch connector.
- 4) Remove the two bolts and the four nuts which secure brake pedal to pedal.

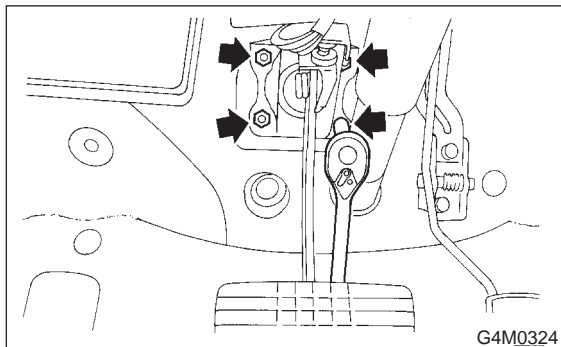

## C: INSPECTION

### 1. BRAKE AND CLUTCH PEDALS

Move brake and clutch pedal pads in the lateral direction with a force of approximately 10 N (1 kg, 2 lb) to ensure pedal deflection is in specified range.

#### **Deflection of brake and clutch pedal:**

##### **Service limit**

**5.0 mm (0.197 in) or less**

#### **CAUTION:**

**If excessive deflection is noted, replace bushings with new ones.**

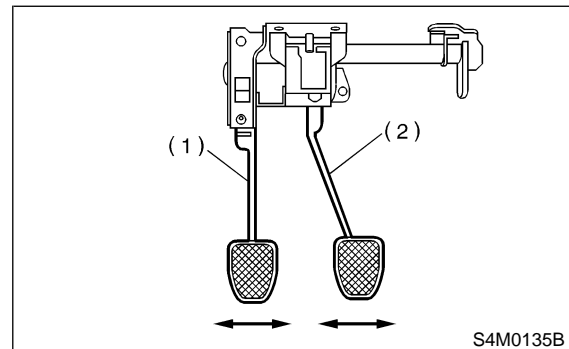

- (1) Clutch pedal
- (2) Brake pedal

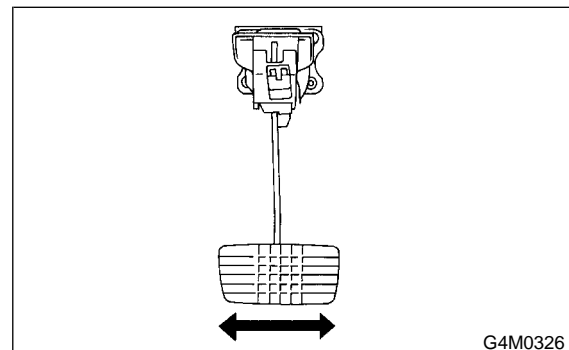

## 1. Pedal

**2. ACCELERATOR PEDAL**

Lightly move pedal pad in lateral the direction to ensure pedal deflection is in specified range.

**Deflection of accelerator pedal:****Service limit**

**5.0 mm (0.197 in) or less**

**CAUTION:**

**If excessive deflection is noted, replace bushing and clip with new ones.**

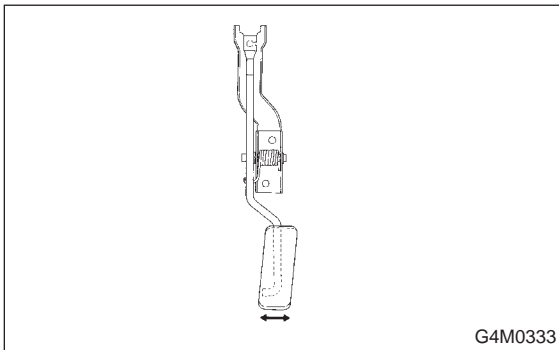
**3. STOP LIGHT SWITCH**

If stop light switch does not operate properly (or if it does not stop at the specified position), replace with a new one.

**Specified position: L**

**$2.8^{+1.5}/_0$  mm ( $0.110^{+0.059}/_0$  in)**

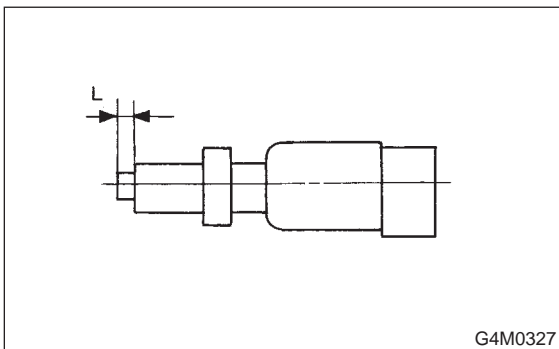
**D: ASSEMBLY****1. BRAKE AND CLUTCH PEDAL**

- 1) Attach stop light switch, etc. to pedal bracket temporarily.
- 2) Clean inside of bores of clutch pedal and brake pedal, apply grease, and set bushings into bores.
- 3) Align bores of pedal bracket, clutch pedal and brake pedal, attach brake pedal return spring and clutch pedal effort reducing spring (vehicle with hill holder), and then install pedal bolt.

**Tightening torque:**

**$T2: 29 \pm 7$  N·m ( $3.0 \pm 0.7$  kg·m,  $21.7 \pm 5.1$  ft·lb)**

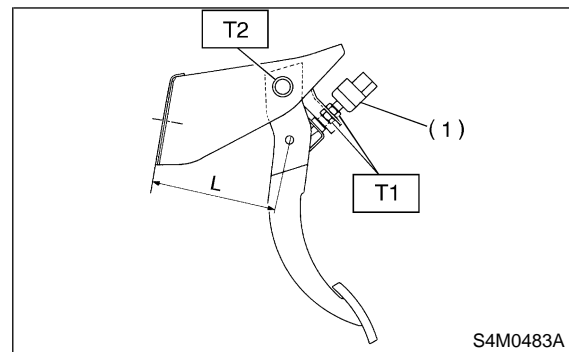

- (1) Stop light switch

**NOTE:**

Clean up inside of bushings and apply grease before installing spacer.

- 4) Set brake pedal position by adjusting position of stop light switch.

**Pedal position: L**

**125.9 mm (4.96 in)**

**Tightening torque:**

**$T1: 8 \pm 2$  N·m ( $0.8 \pm 0.2$  kg·m,  $5.8 \pm 1.4$  ft·lb)**

**2. ACCELERATOR PEDAL**

Clean and apply grease to spacer and inside bore of accelerator pedal. Install accelerator pedal onto pedal bracket.

**E: INSTALLATION**

1) Install in the reverse order of removal.

**CAUTION:**

- Be careful not to bend clutch cable too much.
- Never fail to cover outer cable end with boot.
- Be careful not to kink accelerator cable.
- Make sure that holder and casing cap are securely connected.

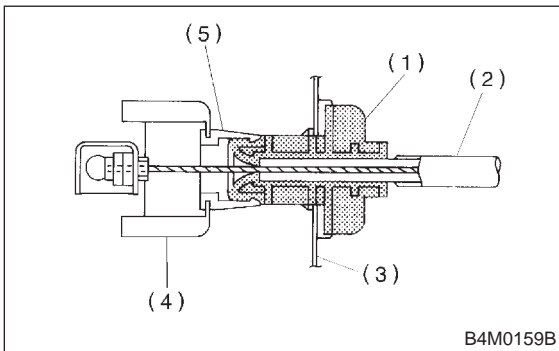

- (1) Casing cap
- (2) Accelerator cable
- (3) Toe board
- (4) Accelerator pedal bracket
- (5) Holder

- 2) Adjust clutch pedal. <Ref. to 4-5 [W1F1].>
- 3) Adjustment after pedal installation; <Ref. to 4-5 [W1A0].>

**F: ADJUSTMENT**

**1. CLUTCH PEDAL**

1) Turn cruise control clutch switch lock nuts until clutch pedal full stroke length is within specifications.

**CAUTION:**

Do not attempt to turn clutch switch to adjust clutch pedal full stroke length.

**NOTE:**

If lock nuts cannot adjust clutch pedal full stroke length to specifications, turn master cylinder push rod to adjust it.

**Specified clutch pedal full stroke: A**  
**130 — 135 mm (5.11 — 5.31 in)**

**Tightening torque (Clutch switch lock nut):**  
**8±2 N·m (0.8±0.2 kg·m, 5.8±1.4 ft·lb)**

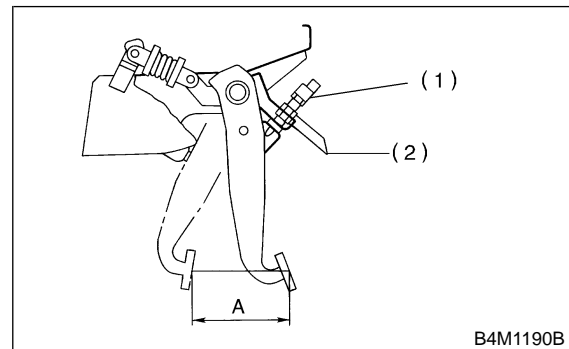

- (1) Clutch switch
- (2) Lock nuts

2) Turn master cylinder push rod so that clevis pin moves to the left and then to the right. Clevis pin must move without resistance while it is rattling.

**Tightening torque (Push rod lock nut):**  
**10±2 N·m (1.0±0.2 kg·m, 7.2±1.4 ft·lb)**

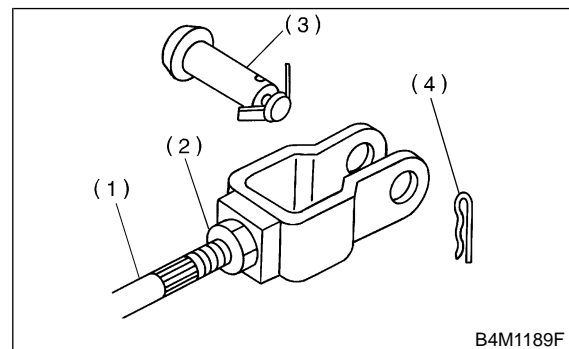

- (1) Push rod
- (2) Lock nut
- (3) Clevis pin
- (4) Snap pin

3) Depress and release clutch pedal 2 to 3 times to ensure that clutch pedal and release fork oper-

## 1. Pedal

ate smoothly. If clutch pedal and release fork do not operate smoothly, bleed air from clutch hydraulic system. <Ref. to 2-10 [W2A0].>

4) Measure clutch pedal full stroke length again to ensure that it is within specifications. If it is not, repeat adjustment procedures again from the beginning.

**Specified clutch pedal full stroke:**

**130 — 135 mm (5.11 — 5.31 in)**

5) Move clevis pin to the left and then to the right. It should move without resistance while it is rattling. If resistance is felt, repeat adjustment procedures again from the beginning.

6) Push release lever until operating cylinder push rod retracts. Ensure that clutch fluid level in reservoir tank increases. If clutch fluid level increases, hydraulic clutch is properly adjusted; if fluid level does not increase or push rod does not retract, replace master cylinder with a new one. <Ref. to 2-10 [W600].>

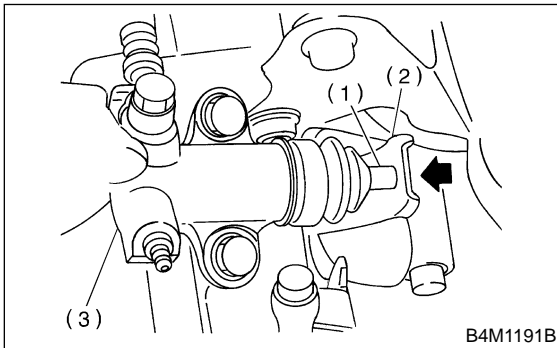

- (1) Push rod
- (2) Release lever
- (3) Operating cylinder



## 2. Accelerator Cable

### A: REMOVAL

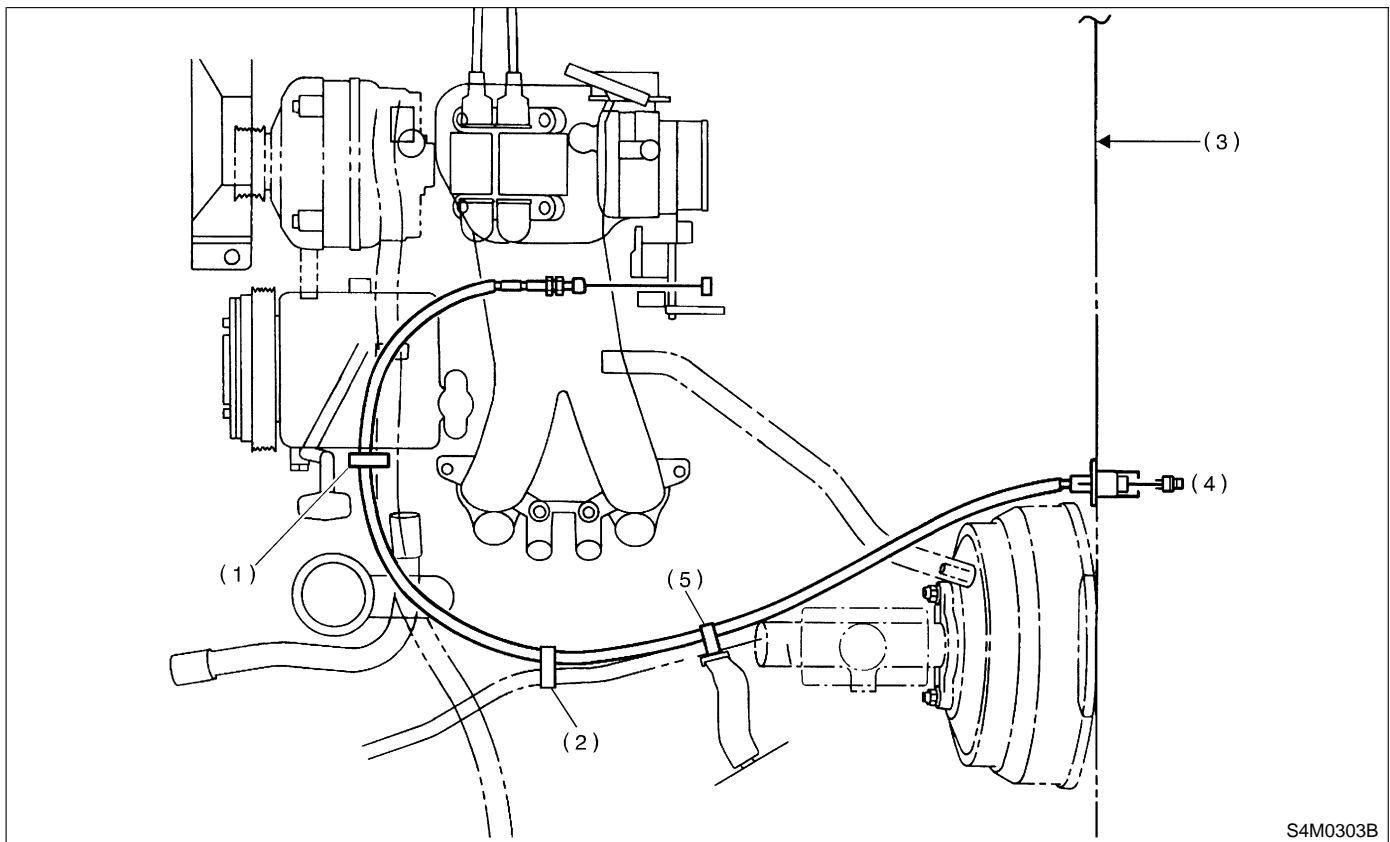

S4M0303B

- |          |                          |          |
|----------|--------------------------|----------|
| (1) Clip | (3) Toe board            | (5) Clip |
| (2) Clip | (4) To accelerator pedal |          |

- 1) Disconnect accelerator cable from connector inside engine compartment first.
- 2) Remove lock nut from accelerator cable bracket.
- 3) Separate accelerator cable (1) from bracket, then unlock inner cable.

- 5) Disconnect cable end from accelerator cable bracket inside driver compartment.
- 6) Remove clip inside engine compartment.
- 7) Working inside engine compartment, remove the casing cap out of the toe board by turning it clockwise.

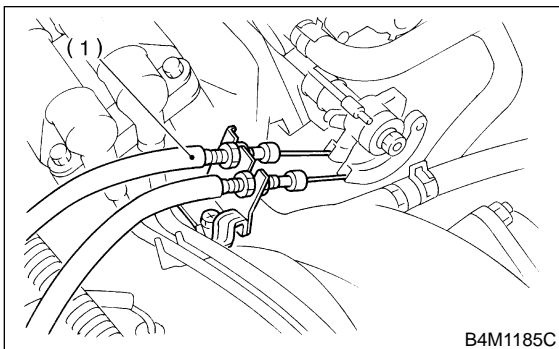

B4M1185C

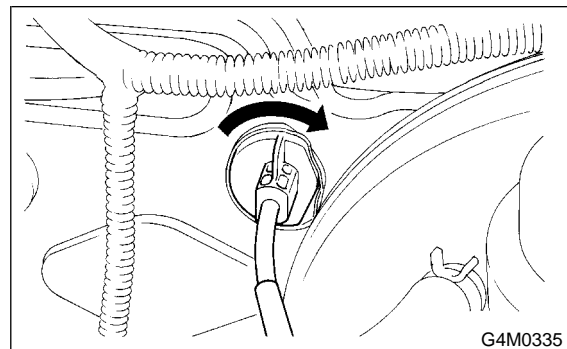

G4M0335

- 4) Remove cable end from throttle cam using your fingertips.

- 8) Pull out the cable from the toe board hole.

**CAUTION:**

**Be careful not to bend inner cable.**

**B: INSTALLATION**

1) Install in the reverse order of removal.

2) Adjustment after cable installation; <Ref. to 4-5 [W1A3].>

**CAUTION:**

- Be careful not to kink accelerator cable.
- Make sure that holder and casing cap are securely connected.

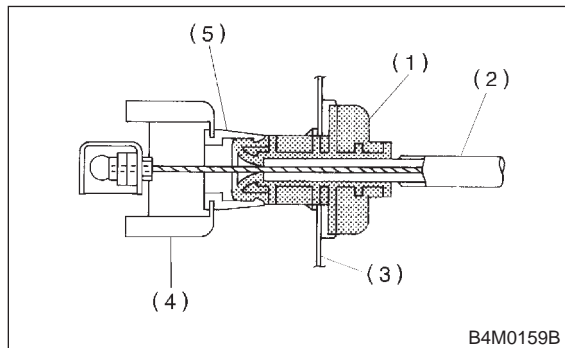

- (1) Casing cap
- (2) Accelerator cable
- (3) Toe board
- (4) Accelerator pedal bracket
- (5) Holder

## 1. Pedal System and Control Cables

Trouble	Corrective action
Excessively worn brake pedal pad	Replace.
Failure of accelerator pedals to operate	Connect cables correctly.
Stop light switch does not light up.	Adjust position of stop light switch.
Stop light switch is not smooth and/or stroke is not correct.	Replace.
Insufficient pedal play	Adjust pedal play.
Clutch and/or brake pedal free play insufficient	Adjust pedal free play.
Maladjustment of brake pedal or booster push rod	Inspect and adjust.
Excessively worn and damaged pedal shaft and/or bushing	Replace bushing and/or shaft with new one.

MEMO:

**1. Specifications****A: HEATER SYSTEM**

Item		Specifications	Condition
Heating capacity		5.1 kW (4,386 kcal/h, 17,404 BTU/h) or more	<ul style="list-style-type: none"> <li>● Mode selector switch: HEAT</li> <li>● Temperature control switch: FULL HOT</li> <li>● Temperature difference between hot water and inlet air: 65°C (149°F)</li> <li>● Hot water flow rate: 360 ℓ (95.1 US gal, 79.2 Imp gal)/h</li> </ul>
Air flow rate		280 m <sup>3</sup> (9,887 cu ft)/h	Heat mode (FRESH), FULL HOT at 12.5 V
Max air flow rate		480 m <sup>3</sup> (16,949 cu ft)/h	<ul style="list-style-type: none"> <li>● Temperature control switch: FULL COLD</li> <li>● Blower fan speed: 4th position</li> <li>● Mode selector lever: RECIRC</li> </ul>
Heater core size (height × length × width)		193.5 × 152 × 35.0 mm (7.62 × 5.98 × 1.378 in)	—
Blower motor	Type	Magnet motor 260 W or less	at 12 V
	Fan type and size (diameter × width)	Sirocco fan type 150 × 75 mm (5.91 × 2.95 in)	—

1. Heater Unit

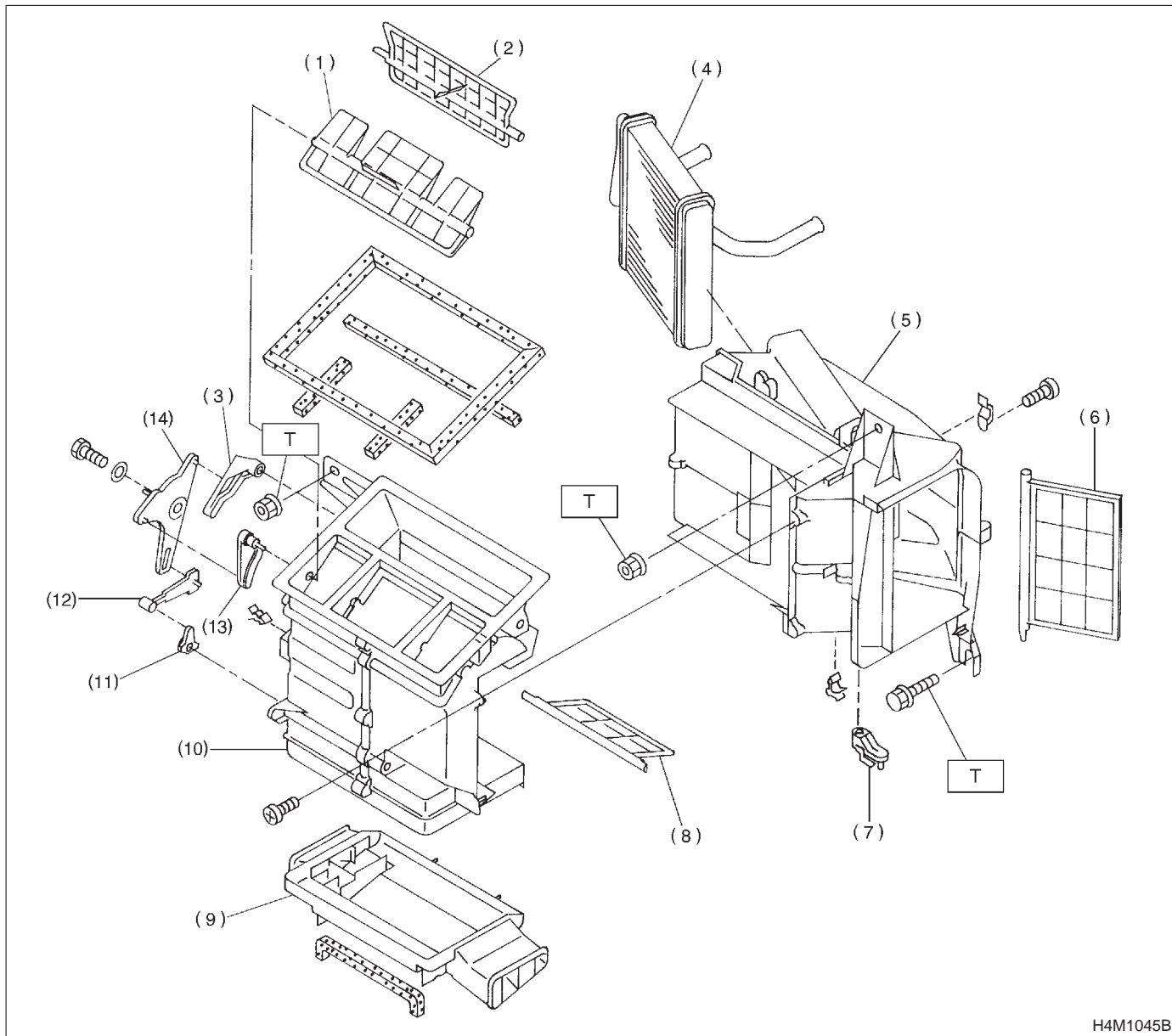

H4M1045B

- (1) Vent door
- (2) DEF door
- (3) DEF lever
- (4) Heater core
- (5) Heater case FRONT
- (6) Mix door

- (7) Mix lever
- (8) Foot door
- (9) Foot duct
- (10) Heater case REAR
- (11) Foot lever lower
- (12) Foot lever upper

- (13) Vent lever
- (14) Side link

**Tightening torque: N·m (kg·m, ft·lb)**  
**T: 7.35±1.96**  
**(0.750±0.200, 5.421±1.446)**

2. Intake Unit

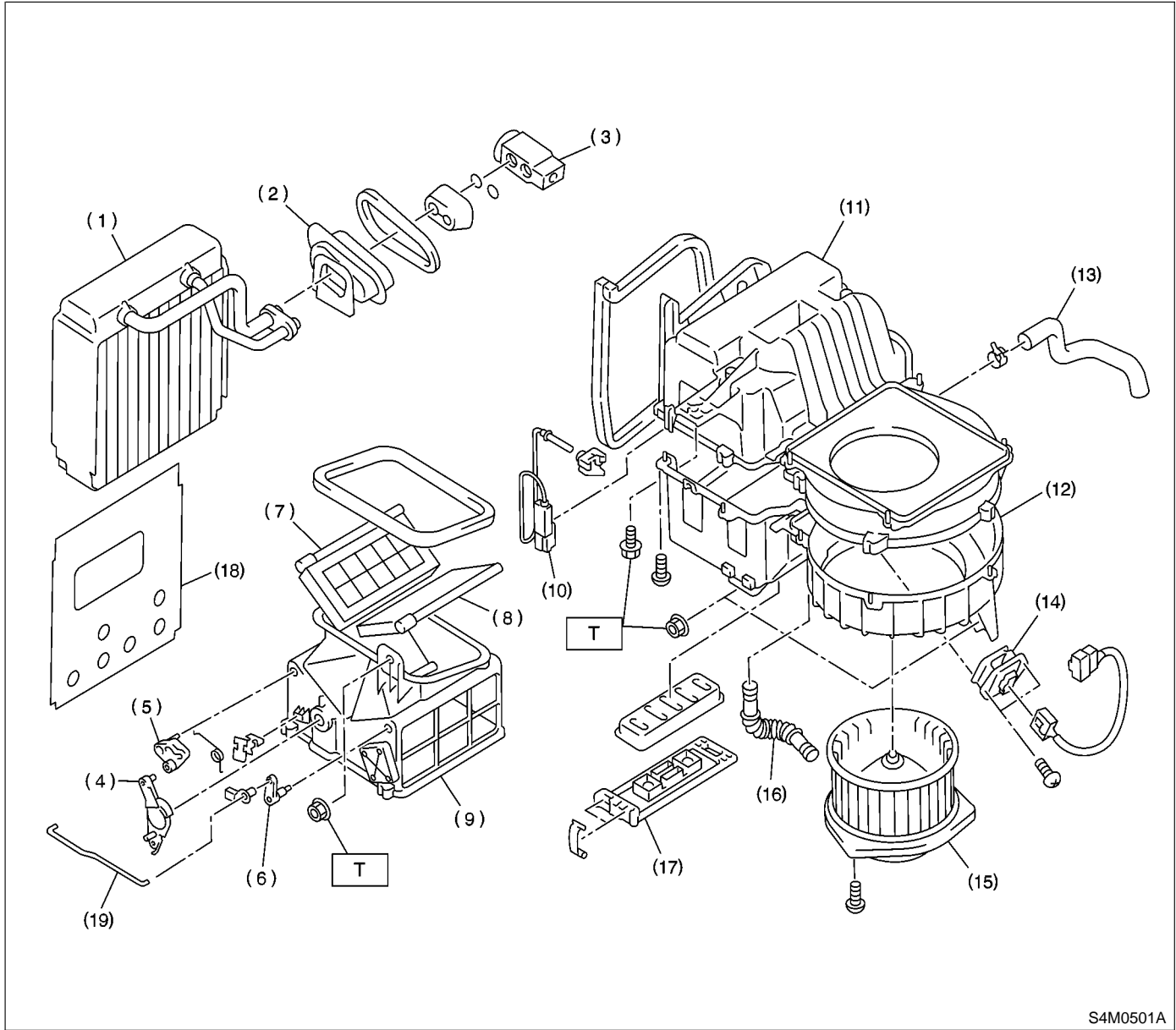

S4M0501A

- |  |                                  |
|--|----------------------------------|
| (1) Evaporator (With A/C model)            | (8) Door (B)                     |
| (2) Boot                                   | (9) Intake unit case inlet       |
| (3) Block expansion valve (With A/C model) | (10) Thermistor (With A/C model) |
| (4) Link                                   | (11) Intake unit case upper      |
| (5) Lever (A)                              | (12) Intake unit case lower      |
| (6) Lever (B)                              | (13) Drain hose                  |
| (7) Door (A)                               | (14) Resistor                    |
|  | (15) Blower motor ASSY           |

- |                     |
|---------------------|
| (16) Aspirator pipe |
| (17) Cover          |
| (18) Separator      |
| (19) Rod            |

**Tightening torque: N·m (kg·m, ft·lb)**

**T: 7.35±1.96**

**(0.750±0.200, 5.421±1.446)**

3. Control Unit

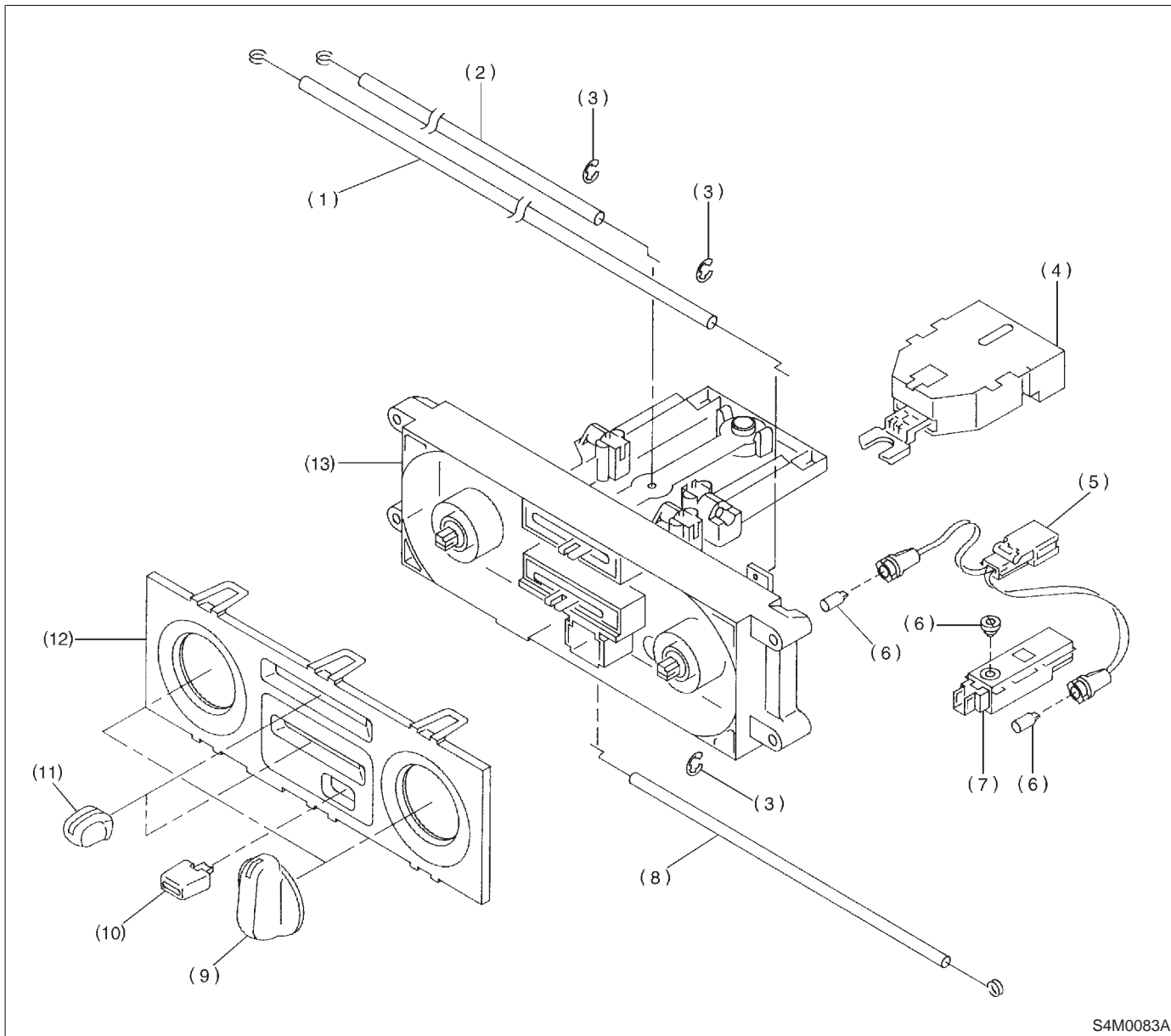

S4M0083A

- |                               |                        |                         |
|-------------------------------|------------------------|-------------------------|
| (1) Temperature control cable | (6) Bulb               | (11) Control lever knob |
| (2) Recirc control cable      | (7) A/C switch ASSY    | (12) Plate              |
| (3) Clip                      | (8) Mode control cable | (13) Base unit          |
| (4) Blower switch ASSY        | (9) Control dial knob  |                         |
| (5) Harness ASSY              | (10) A/C switch knob   |                         |



## 1. Precaution

### A: SUPPLEMENTAL RESTRAINT SYSTEM "AIRBAG"

Airbag system wiring harness is routed near the instrument panel, heater unit, blower motor and control unit.

#### CAUTION:

- All airbag system wiring harness and connectors are yellow. Do not use electrical test equipment on these circuits.
- Be careful not to damage airbag system wiring harness when servicing the instrument panel, heater unit, blower motor and control unit.

## 2. Heater Unit

### A: REMOVAL AND INSTALLATION

- 1) Disconnect ground cable from battery.
- 2) Remove heater hoses (inlet, outlet) in engine compartment.

#### NOTE:

Drain as much coolant from heater unit as possible, and plug disconnected hose with cloth.

- 3) Remove instrument panel.  
<Ref. to 5-4 [W1A0].>
- 4) Remove steering support beam.  
<Ref. to 5-1 [C500].>
- 5) Remove cooling unit.  
<Ref. to 4-7 [W14A0].>
- 6) Remove heater unit.

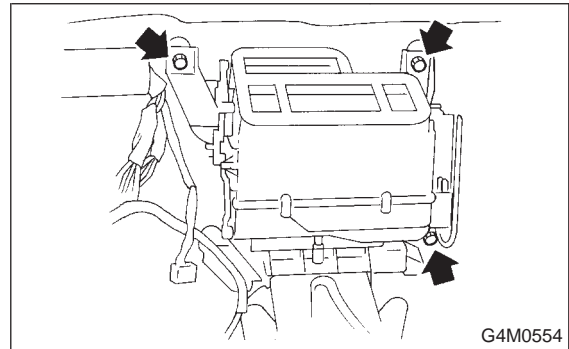

G4M0554

- 7) Install in the reverse order of removal.

**Fitted length of heater hose over pipe:  
27.5±2.5 mm (1.083±0.098 in)**

- 8) Pour coolant.

## 1. Precaution

### A: SUPPLEMENTAL RESTRAINT SYSTEM "AIRBAG"

Airbag system wiring harness is routed near the instrument panel, heater unit, blower motor and control unit.

#### CAUTION:

- All airbag system wiring harness and connectors are yellow. Do not use electrical test equipment on these circuits.
- Be careful not to damage airbag system wiring harness when servicing the instrument panel, heater unit, blower motor and control unit.

## 2. Heater Unit

### A: REMOVAL AND INSTALLATION

- 1) Disconnect ground cable from battery.
- 2) Remove heater hoses (inlet, outlet) in engine compartment.

#### NOTE:

Drain as much coolant from heater unit as possible, and plug disconnected hose with cloth.

- 3) Remove instrument panel.  
<Ref. to 5-4 [W1A0].>
- 4) Remove steering support beam.  
<Ref. to 5-1 [C500].>
- 5) Remove cooling unit.  
<Ref. to 4-7 [W14A0].>
- 6) Remove heater unit.

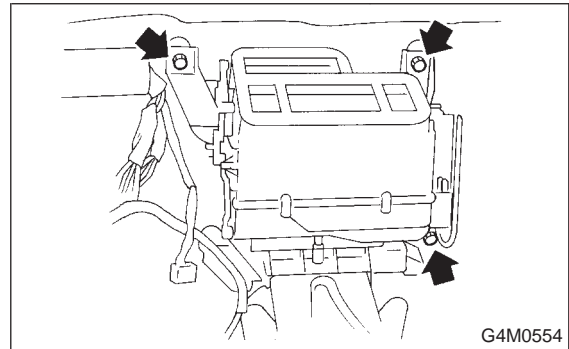

G4M0554

- 7) Install in the reverse order of removal.

**Fitted length of heater hose over pipe:  
27.5±2.5 mm (1.083±0.098 in)**

- 8) Pour coolant.

### 3. Blower Motor Assembly

#### A: REMOVAL AND INSTALLATION

- 1) Disconnect ground cable from battery.
- 2) Remove glove box.

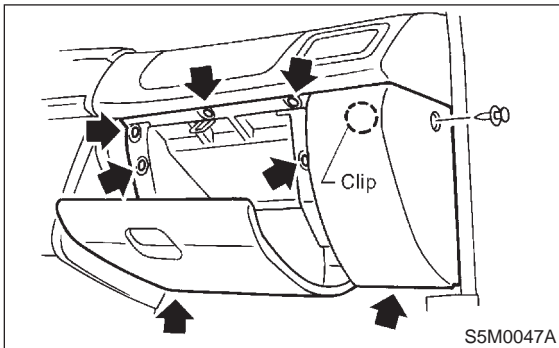

- 3) Disconnect blower motor harness connector.
- 4) Disconnect aspirator pipe (A).
- 5) Remove blower motor mounting screw.

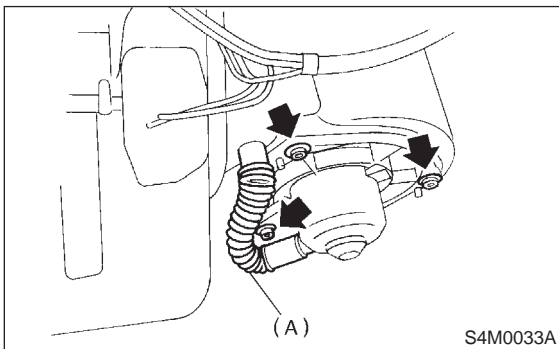

- 6) Remove blower motor assembly.
- 7) Install in the reverse order of removal.

### 4. Control Unit

#### A: REMOVAL AND INSTALLATION

- 1) Disconnect ground cable from battery.
- 2) Set temperature control switch to "FULL HOT" and mode selector switch to "DEF" position and recirc switch to "FRESH" position.
- 3) Disconnect temperature control cable and mode door control cable from heater unit then disconnect recirc control cable from intake unit.

**NOTE:**

Do not attempt to move links during installation.

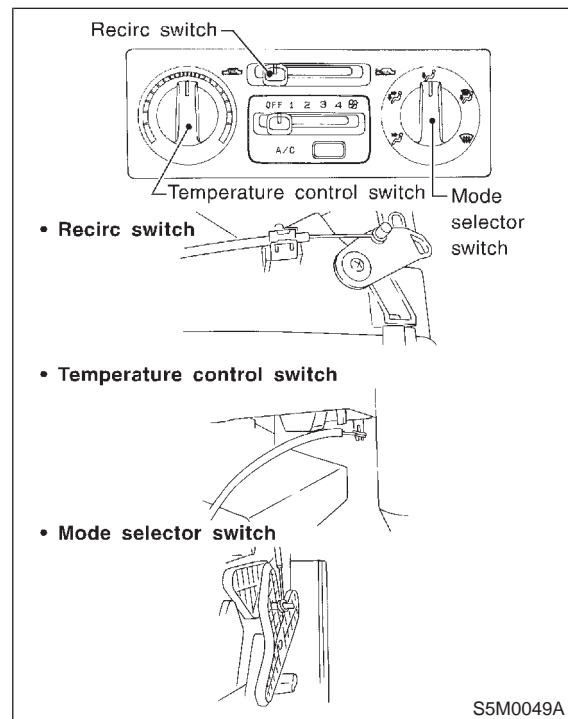

- 4) Remove console box. <Ref. to 5-4 [W1A0].>
- 5) Remove center panel and then disconnect connector.
- 6) Remove audio.

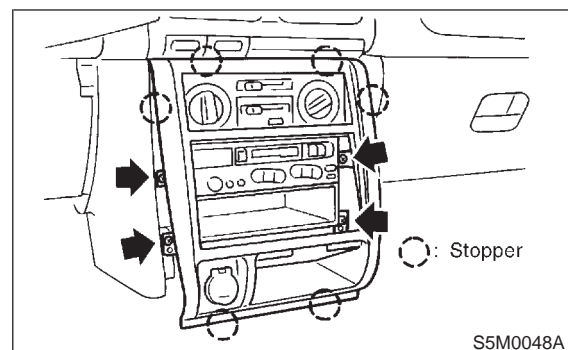

### 3. Blower Motor Assembly

#### A: REMOVAL AND INSTALLATION

- 1) Disconnect ground cable from battery.
- 2) Remove glove box.

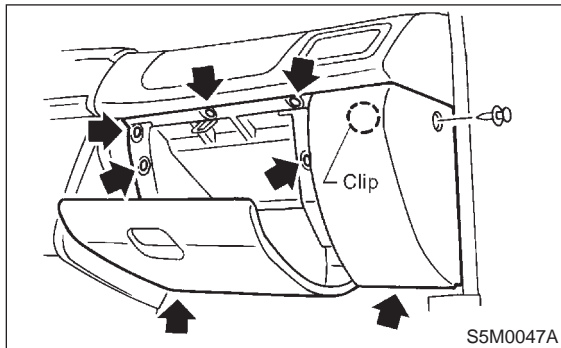

- 3) Disconnect blower motor harness connector.
- 4) Disconnect aspirator pipe (A).
- 5) Remove blower motor mounting screw.

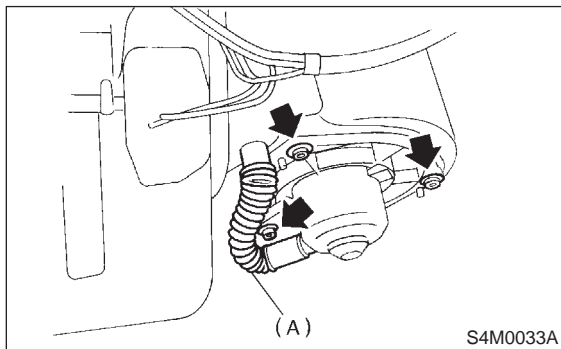

- 6) Remove blower motor assembly.
- 7) Install in the reverse order of removal.

### 4. Control Unit

#### A: REMOVAL AND INSTALLATION

- 1) Disconnect ground cable from battery.
- 2) Set temperature control switch to "FULL HOT" and mode selector switch to "DEF" position and recirc switch to "FRESH" position.
- 3) Disconnect temperature control cable and mode door control cable from heater unit then disconnect recirc control cable from intake unit.

**NOTE:**

Do not attempt to move links during installation.

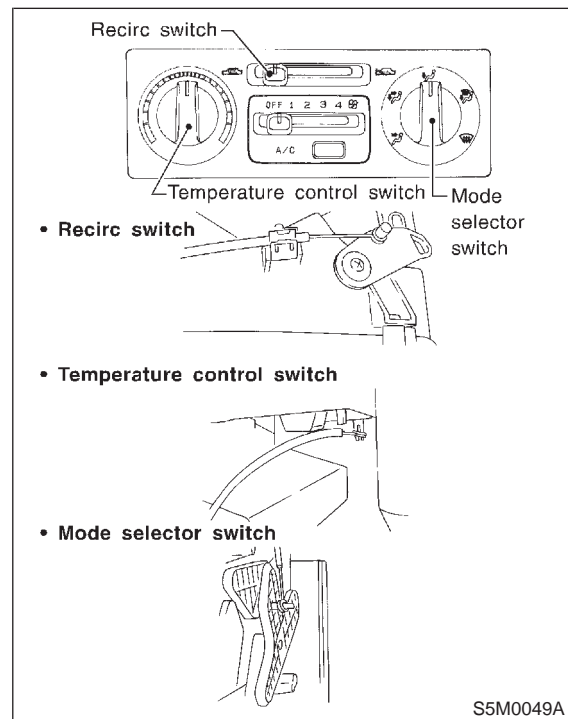

- 4) Remove console box. <Ref. to 5-4 [W1A0].>
- 5) Remove center panel and then disconnect connector.
- 6) Remove audio.

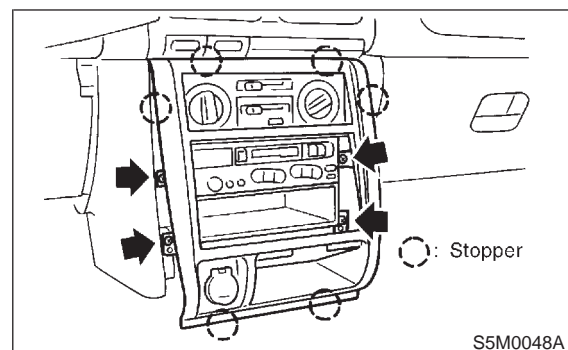

7) Remove control unit assembly from center console.

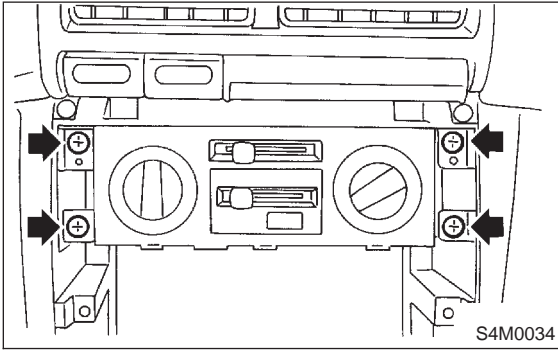

8) Install in the reverse order of removal.

**NOTE:**

Before installing control unit, set temperature control switch to "FULL HOT" and mode selector switch to "DEF" position and recirc switch to "FRESH" position.

**B: INSPECTION**

**1. FAN SWITCH**

Check continuity between terminals at each switch position.

Switch position	Terminals					
	1	2	3	4	5	6
1	○				○	○
2	○			○		○
3	○		○			○
4	○	○				○
	IGN					GND

H5M1280A

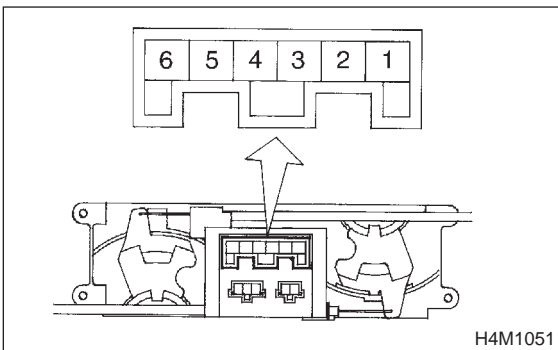

**2. A/C SWITCH**

Check A/C switch continuity between each terminal.

Terminal	Switch ON	Illumi.
1		○
2	○	○
3	○	○

H5M1281A

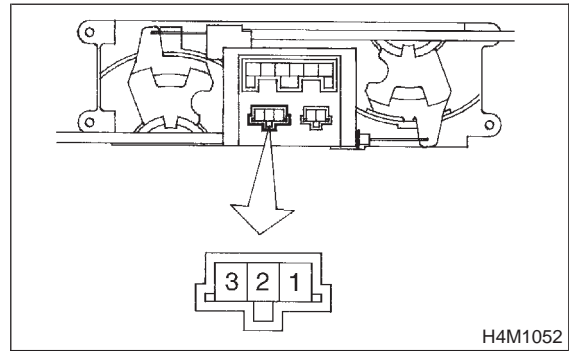

**C: ADJUSTMENT**

- 1) Operate temperature control switch to "FULL COLD" and mode selector switch to "VENT" position and recirc switch to "RECIRC" position.
- 2) Install control cable to lever. While pushing outer cable, secure control cable with clip.

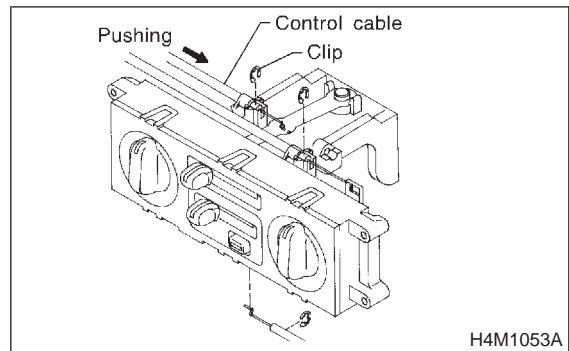

## 1. Specifications

Item		Specifications	
Type of air conditioner		Reheat air-mix type	
Cooling capacity		5.117 kW (4,400 kcal/h, 17,459 BTU/h)	
Refrigerant		HFC-134a (CH <sub>2</sub> FCF <sub>3</sub> ) [0.65±0.05 kg (1.43±0.11 lb)]	
Compressor	Type	5-vane rotary, fix volume (KC50G)	
	Discharge	140 cm <sup>3</sup> (8.54 cu in)/rev	
	Max. permissible speed	7,000 rpm	
Magnet clutch	Type	Dry, single-disc type	
	Power consumption	38 W	
	Type of belt	V-Ribbed 4 PK	
	Pulley dia. (effective dia.)	125 mm (4.92 in)	
	Pulley ratio	1.064	
Condenser	Type	Corrugated fin (Multi-flow)	
	Core face area	0.255 m <sup>2</sup> (2.74 sq ft)	
	Dimensions (W × H × T)	22 × 374 × 683 mm (0.87 × 14.72 × 26.89 in)	
	Radiation area	6.52 m <sup>2</sup> (70 sq ft)	
Receiver drier	Effective inner capacity	250 cm <sup>3</sup> (15.26 cu in)	
Expansion valve	Type	Internal equalizing	
Evaporator	Type	Single tank	
	Dimensions (W × H × T)	60 × 224 × 235 mm (2.36 × 8.82 × 9.25 in)	
Blower fan	Fan type	Sirocco fan	
	Outer diameter × width	150 × 75 mm (5.91 × 2.95 in)	
	Power consumption	260 W at 12 V	
Condenser fan (Sub fan)	Motor type	Magnet	
	Power consumption	70 W at 12 V	
	Fan outer diameter	320 mm (12.60 in)	
Radiator fan (Main fan)	Motor type	Magnet	
	Power consumption	70 W at 12 V	
	Fan outer diameter	320 mm (12.60 in)	
Dual switch (Pressure switch)	Low-pressure switch operating pressure	ON → OFF	177±25 kPa (1.80±0.25 kg/cm <sup>2</sup> , 25.6±3.6 psi)
		OFF → ON	Less than 216 kPa (2.2 kg/cm <sup>2</sup> , 31 psi)
	High-pressure switch operating pressure	ON → OFF	2,940±200 kPa (29.98±2.04 kg/cm <sup>2</sup> , 426.3±29.0 psi)
		DIFF	590±200 kPa (6.02±2.04 kg/cm <sup>2</sup> , 85.6±29.0 psi)
Compressor relief valve blow-out pressure		3,600±300 kPa (36.71±3.06 kg/cm <sup>2</sup> , 522.0±43.5 psi)	
Thermo control amplifier working temperature (Evaporator outlet air)		<p>Diff. 1.5±0.5°C (35±0.9°F)</p> <p>3.0±0.3°C (37±0.5°F)</p>	

S4M0511A

1. Air Conditioning System

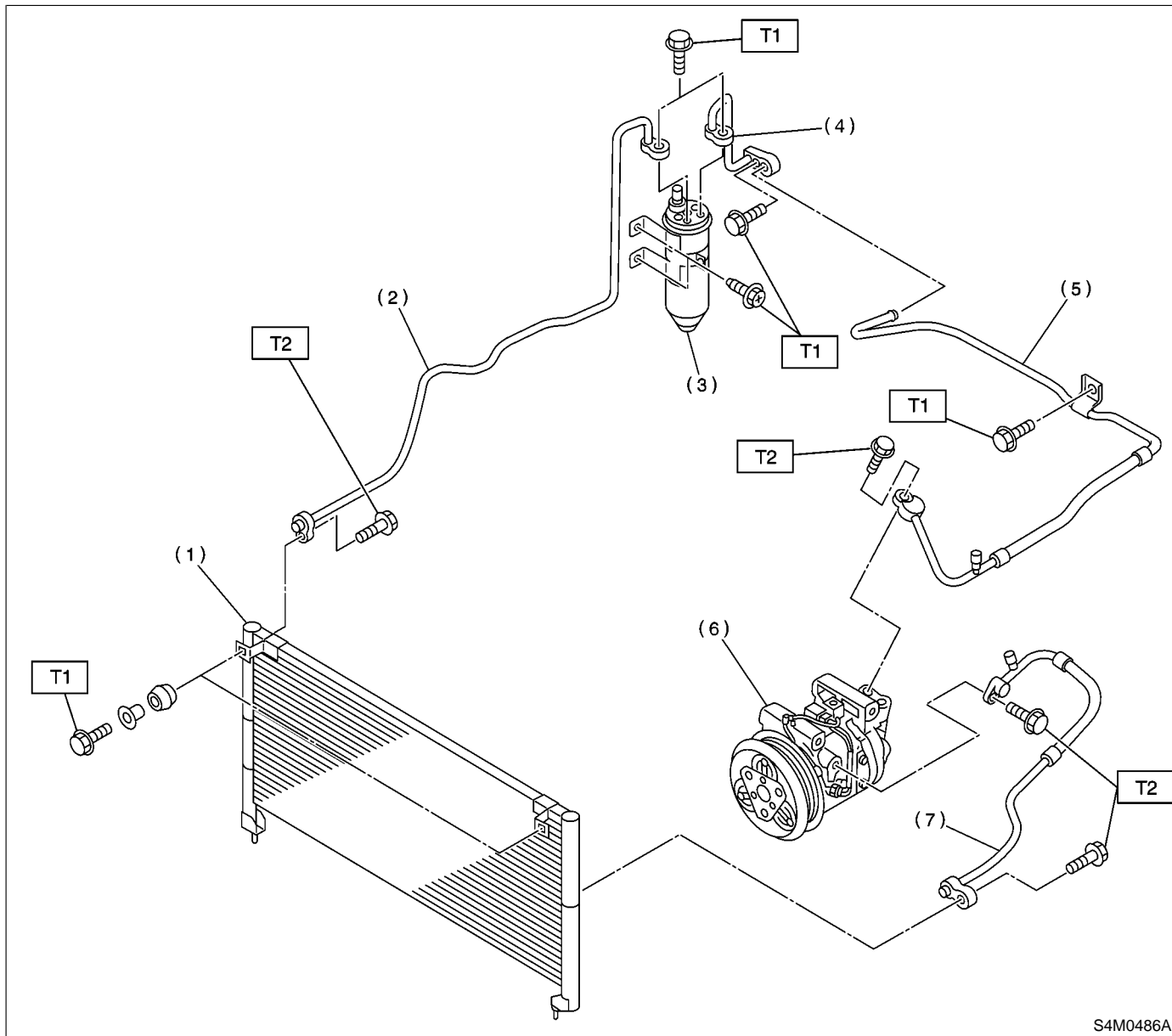

S4M0486A

- (1) Condenser
- (2) Pipe (From condenser to receiver drier)
- (3) Receiver drier
- (4) Pipe (From receiver drier to intake unit)
- (5) Hose (Low-pressure)
- (6) Compressor
- (7) Hose (High-pressure)

**Tightening torque: N·m (kg·m, ft·lb)**

**T1: 7.4±2.0 (0.75±0.2, 5.4±1.4)**

**T2: 15±5 (1.5±0.5, 10.8±3.6)**

## 2. Intake Unit with Evaporator

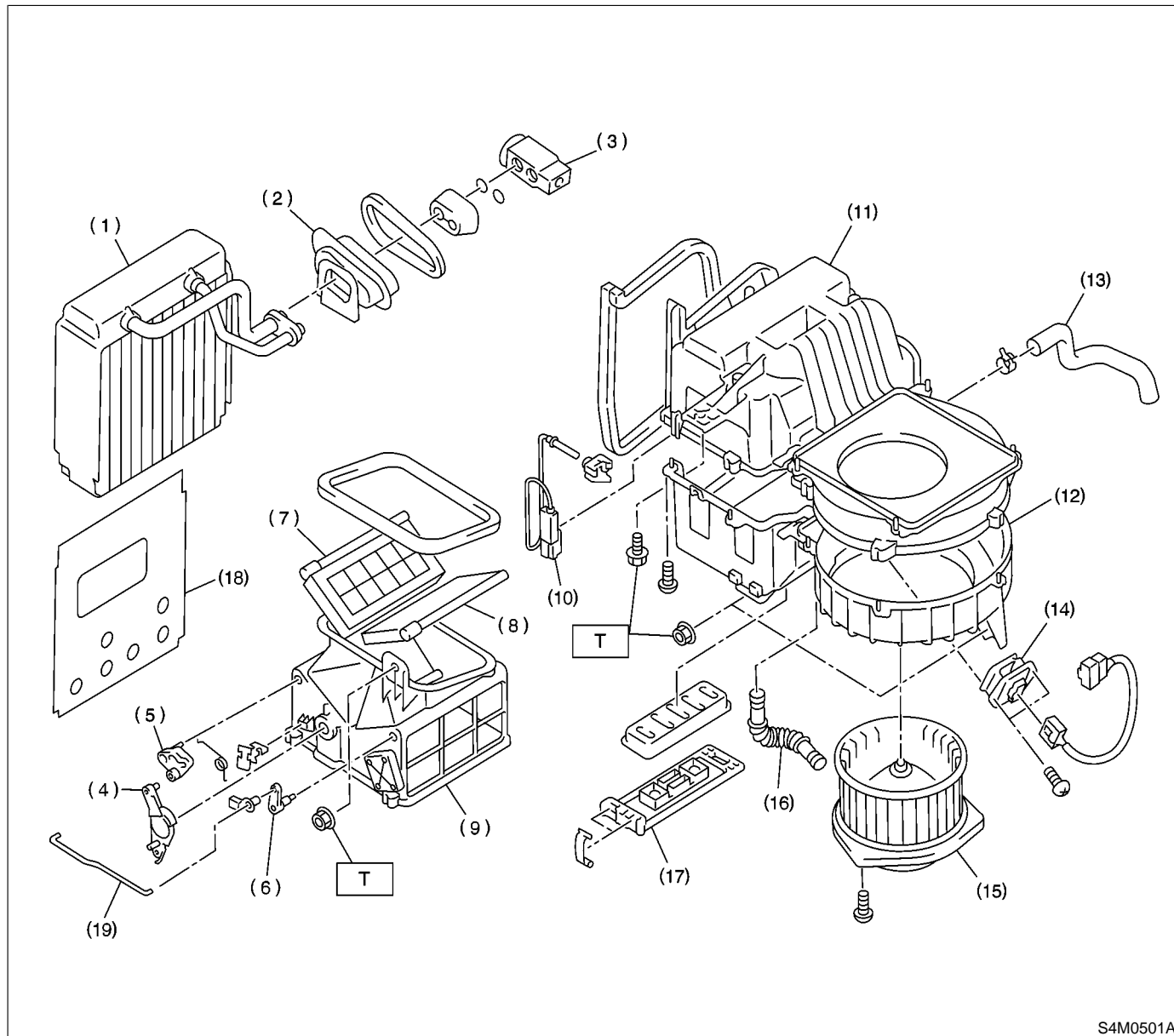

S4M0501A

- |                           |                             |                |
|---------------------------|-----------------------------|----------------|
| (1) Evaporator            | (9) Intake unit case inlet  | (17) Cover     |
| (2) Boot                  | (10) Thermistor             | (18) Separator |
| (3) Block expansion valve | (11) Intake unit case upper | (19) Rod       |
| (4) Link                  | (12) Intake unit case lower |                |
| (5) Lever (A)             | (13) Drain hose             |                |
| (6) Lever (B)             | (14) Resistor               |                |
| (7) Door (A)              | (15) Blower motor ASSY      |                |
| (8) Door (B)              | (16) Aspirator pipe         |                |

---

**Tightening torque: N·m (kg·m, ft·lb)**
**T: 7.35±1.96**
**(0.750±0.200, 5.421±1.446)**

---



3. Compressor

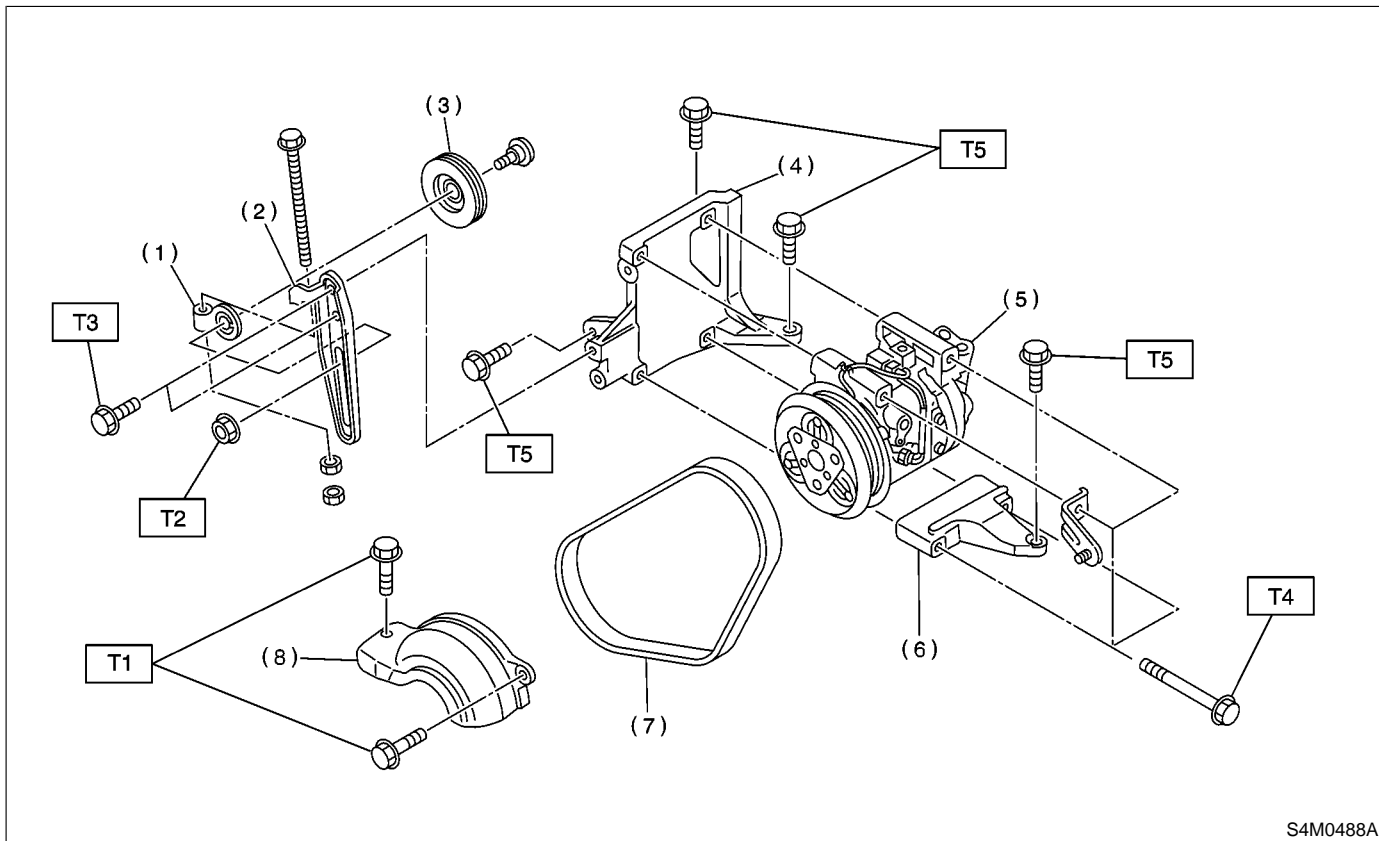

S4M0488A

- (1) Idler pulley adjuster
- (2) Idler pulley bracket
- (3) Idler pulley
- (4) Compressor bracket upper
- (5) Compressor
- (6) Compressor bracket lower
- (7) V-belt
- (8) Compressor belt cover

**Tightening torque: N·m (kg·m, ft·lb)**

**T1: 7.4±2 (0.75±0.2, 5.4±1.4)**

**T2: 23±3 (2.3±0.3, 17±2.2)**

**T3: 23.0±3 (2.35±0.3, 17.0±2.2)**

**T4: 28.9±4.4 (2.95±0.45, 21.3±3.3)**

**T5: 35±4 (3.6±0.4, 26±2.9)**

## 1. Safety Precautions

### A: HFC-134a AIR CONDITIONING SYSTEM

Component parts of the cooling system, refrigerant, compressor oil, and other parts are not the same for the HFC-134a system and the older CFC-12 system. Do not interchange parts or liquid. Vehicles with HFC-134a air conditioning systems, use only HFC-134a parts that are indicated on a label (A) attached to the vehicle. Before performing any maintenance, verify the type of air conditioning system installed in the vehicle.

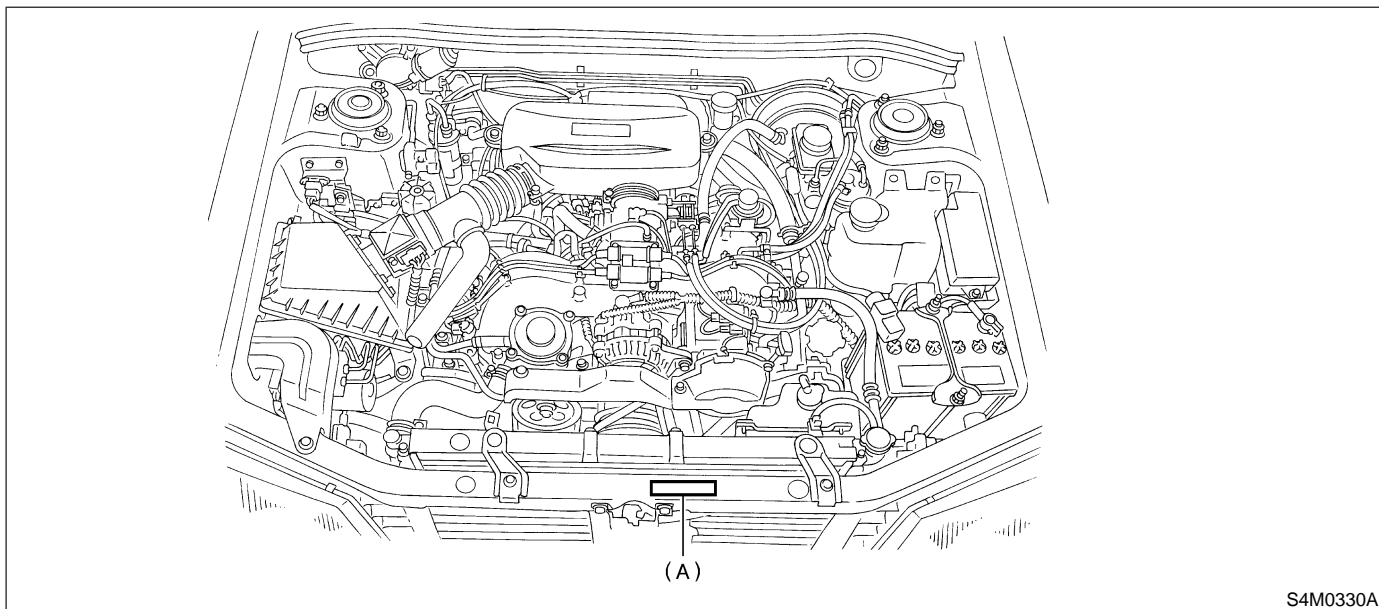

S4M0330A

### B: COMPRESSOR OIL

Do not use any compressor oil that is not specifically designated for the HFC-134a air conditioning system; only use ZXL200PG. Also, do not use HFC-134a compressor oil in the CFC-12 air conditioning system. If compression oils are mixed, poor lubrication will result and the compressor itself may be damaged.

Because HFC-134a compressor oil is very hygroscopic (easily absorbs moisture), when parts of the air conditioning system are being removed, quickly install a blind plug to prevent contact with the outside air. Also, always make sure that the service container for compressor oil is tightly closed except when in use. Store compressor oil in a tightly closed steel container.

### C: REFRIGERANT

Do not put CFC-12 refrigerant into a HFC-134a air conditioning system. Also, do not put HFC-134a refrigerant into a CFC-12 air conditioning system. If the wrong refrigerant is used, poor lubrication will result and the compressor itself may be destroyed.

**D: HANDLING OF REFRIGERANT**

Because refrigerant boils at approx. -30°C (-22°F) at sea level, it is cold enough to give you severe frostbite. Always wear goggles to protect your eyes and gloves to protect your hands. Also, even under the pressures normally found in CFC-12 containers, refrigerant will boil with the addition of heat. This could raise the pressure inside the container to a dangerous level.

Never expose a can of HFC-134a to direct sunlight, or to temperatures over 40°C (104°F). One more thing to remember about HFC-134a is that when it is exposed to an open flame or to hot metal, it forms phosgene, a deadly gas. Do not discharge HFC-134a into the atmosphere on purpose. Always read and follow the precautions on the HFC-134a bottle.

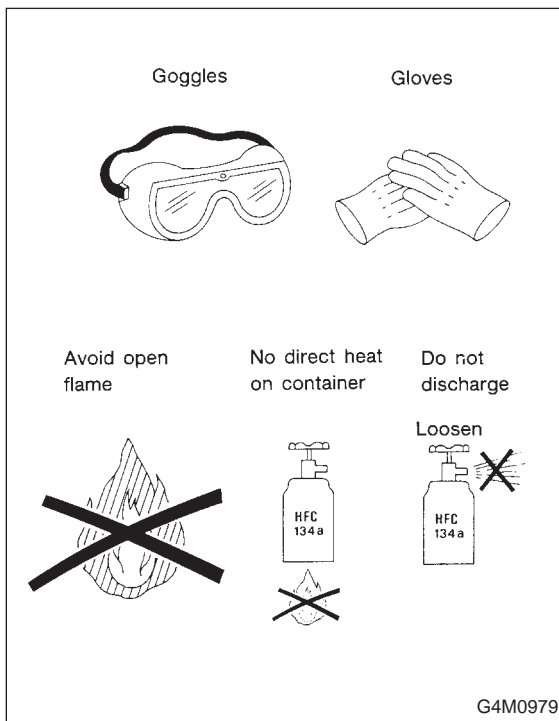

**2. Basic Information**

1) The combination of moisture and refrigerant forms acid, therefore, moisture should not be allowed to enter the refrigerant.

2) Refrigerant oil readily absorbs moisture, therefore, keep refrigerant oil containers tightly capped.

3) The process of evacuating the system is performed to remove small amounts of moisture. This is accomplished by lowering the pressure inside the system, which allows the moisture to boil off, in much the same way that a pot of water will boil away to nothing given enough time. The evacuation process does not suck the moisture out of the system.

4) A minimum level of vacuum must be reached to satisfactorily evacuate the system. This minimum level of vacuum depends on the temperature inside the system. The chart below shows the level of vacuum required to boil water at various temperatures.

Additionally, the vacuum level shown on a gauge will read approx. 3.3 kPa (25 mmHg, 1 inHg) less for each 304.8 m (1,000 ft) above sea level, due to the decrease in atmospheric pressure at altitude.

Vacuum level required to boil water (at sea level)	
Temperature	Vacuum
1.7°C (35°F)	100.9 kPa (757 mmHg, 29.8 inHg)
7.2°C (45°F)	100.6 kPa (754 mmHg, 29.7 inHg)
12.8°C (55°F)	99.9 kPa (749 mmHg, 29.5 inHg)
18.3°C (65°F)	99.2 kPa (744 mmHg, 29.3 inHg)
23.9°C (75°F)	98.5 kPa (739 mmHg, 29.1 inHg)
29.4°C (85°F)	97.2 kPa (729 mmHg, 28.7 inHg)
35°C (95°F)	95.8 kPa (719 mmHg, 28.3 inHg)

## D: HANDLING OF REFRIGERANT

Because refrigerant boils at approx.  $-30^{\circ}\text{C}$  ( $-22^{\circ}\text{F}$ ) at sea level, it is cold enough to give you severe frostbite. Always wear goggles to protect your eyes and gloves to protect your hands. Also, even under the pressures normally found in CFC-12 containers, refrigerant will boil with the addition of heat. This could raise the pressure inside the container to a dangerous level.

Never expose a can of HFC-134a to direct sunlight, or to temperatures over  $40^{\circ}\text{C}$  ( $104^{\circ}\text{F}$ ). One more thing to remember about HFC-134a is that when it is exposed to an open flame or to hot metal, it forms phosgene, a deadly gas. Do not discharge HFC-134a into the atmosphere on purpose. Always read and follow the precautions on the HFC-134a bottle.

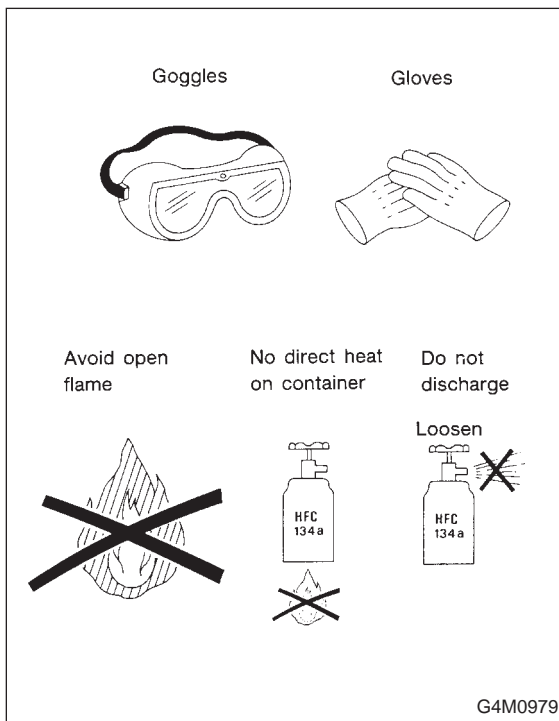

## 2. Basic Information

1) The combination of moisture and refrigerant forms acid, therefore, moisture should not be allowed to enter the refrigerant.

2) Refrigerant oil readily absorbs moisture, therefore, keep refrigerant oil containers tightly capped.

3) The process of evacuating the system is performed to remove small amounts of moisture. This is accomplished by lowering the pressure inside the system, which allows the moisture to boil off, in much the same way that a pot of water will boil away to nothing given enough time. The evacuation process does not suck the moisture out of the system.

4) A minimum level of vacuum must be reached to satisfactorily evacuate the system. This minimum level of vacuum depends on the temperature inside the system. The chart below shows the level of vacuum required to boil water at various temperatures.

Additionally, the vacuum level shown on a gauge will read approx. 3.3 kPa (25 mmHg, 1 inHg) less for each 304.8 m (1,000 ft) above sea level, due to the decrease in atmospheric pressure at altitude.

Vacuum level required to boil water (at sea level)	
Temperature	Vacuum
1.7°C (35°F)	100.9 kPa (757 mmHg, 29.8 inHg)
7.2°C (45°F)	100.6 kPa (754 mmHg, 29.7 inHg)
12.8°C (55°F)	99.9 kPa (749 mmHg, 29.5 inHg)
18.3°C (65°F)	99.2 kPa (744 mmHg, 29.3 inHg)
23.9°C (75°F)	98.5 kPa (739 mmHg, 29.1 inHg)
29.4°C (85°F)	97.2 kPa (729 mmHg, 28.7 inHg)
35°C (95°F)	95.8 kPa (719 mmHg, 28.3 inHg)

### 3. Tools and Equipment

The following section provides information about the tools and equipment that will be necessary to properly service the A/C system.

Since equipment may vary slightly depending on the manufacturer, it is important to always read and follow the manufacturer's instructions.

**CAUTION:**

**When working on vehicles with the HFC-134a system, only use HFC-134a specified tools and parts. Do not mix with CFC-12 tools and parts. If HFC-134a and CFC-12 refrigerant or compressor oil is mixed, poor lubrication will result and the compressor itself may be destroyed.**

In order to help prevent mixing HFC-134a and CFC-12 parts and liquid, the tool and screw type and the type of service valves used are different. The gas leak detectors for the HFC-134a and CFC-12 systems must also not be interchanged.

	HFC-134a	CFC-12
Tool & screw type	Millimeter size	Inch size
Valve type	Quick joint type	Screw-in type

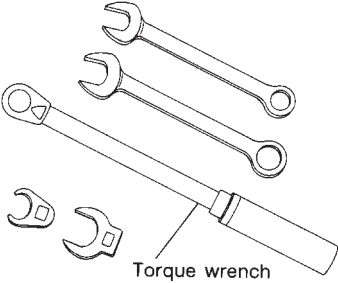
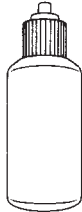
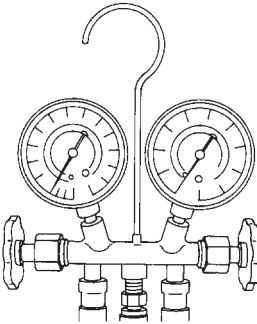
Tools and Equipment	Description
<p>● WRENCH</p> <p>Various <b>WRENCHES</b> will be required to service any A/C system. A 7 to 40 N·m (0.7 to 4.1 kg·m, 5 to 30 ft·lb) torque wrench with various crowfoot wrenches will be needed. Open end or flare nut wrenches will be needed for back-up on the tube and hose fittings.</p>	 <p style="text-align: right;">G4M0571</p>
<p>● APPLICATOR BOTTLE</p> <p>A small <b>APPLICATOR BOTTLE</b> is recommended to apply refrigerant oil to the various parts. They can be obtained at a hardware or drug store.</p>	 <p style="text-align: right;">G4M0572</p>
<p>● MANIFOLD GAUGE SET</p> <p>A <b>MANIFOLD GAUGE SET</b> (with hoses) can be obtained from either a commercial refrigeration supply house or from an auto shop equipment supplier.</p>	 <p style="text-align: right;">G4M0573</p>

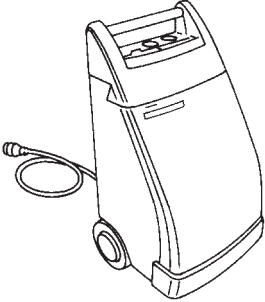
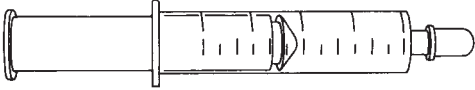
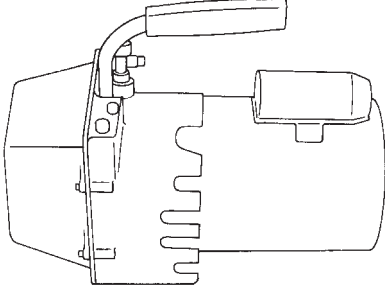
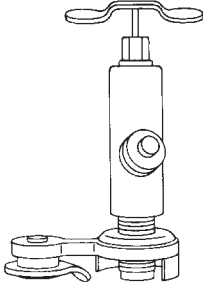
Tools and Equipment	Description
<p>● <b>REFRIGERANT RECOVERY SYSTEM</b></p> <p>A <b>REFRIGERANT RECOVERY SYSTEM</b> is used for the recovery and reuse of A/C system refrigerant after contaminants and moisture have been removed from the refrigerant.</p>	 <p style="text-align: right;">G4M0574</p>
<p>● <b>SYRINGE</b></p> <p>A graduated plastic <b>SYRINGE</b> will be needed to add oil back into the system. The syringe can be found at a pharmacy or drug store.</p>	 <p style="text-align: right;">G4M0575</p>
<p>● <b>VACUUM PUMP</b></p> <p>A <b>VACUUM PUMP</b> (in good working condition) is necessary, and may be obtained from either a commercial refrigeration supply house or an automotive equipment supplier.</p>	 <p style="text-align: right;">G4M0576</p>
<p>● <b>CAN TAP</b></p> <p>A <b>CAN TAP</b> for the 397 g (14 oz) can is available from an auto supply store.</p>	 <p style="text-align: right;">G4M0577</p>

3. Tools and Equipment

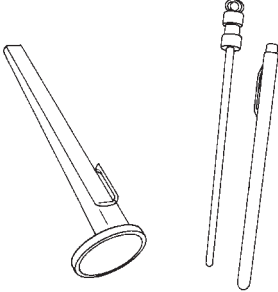
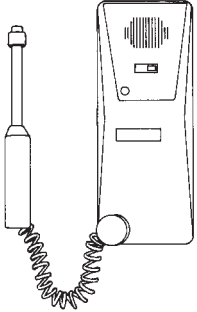
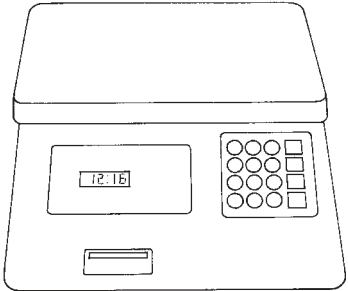
Tools and Equipment	Description
<p>● THERMOMETER</p> <p>Pocket <b>THERMOMETERS</b> are available from either industrial hardware store or commercial refrigeration supply houses.</p>	 <p style="text-align: right;">G4M0578</p>
<p>● ELECTRONIC LEAK DETECTOR</p> <p>An <b>ELECTRONIC LEAK DETECTOR</b> can be obtained from either a specialty tool supply or an A/C equipment supplier.</p>	 <p style="text-align: right;">G4M0579</p>
<p>● WEIGHT SCALE</p> <p>A <b>WEIGHT SCALE</b> such as an electronic charging scale or a bathroom scale with digital display will be needed if a 13.6 kg (30 lb) refrigerant container is used.</p>	 <p style="text-align: right;">G4M0580</p>

## 4. O-ring Connections

### A: GENERAL

The following points should be kept in mind when assembling O-ring connections:

- 1) Avoid unnecessary handling and contact of O-rings with your hands, since even clean fingers contain body acids, which can contaminate the O-ring surface.
- 2) Do not handle O-rings with gloves, shop towels, etc., since lint particles may cling to the O-ring, possibly causing a leak upon assembly.
- 3) Always lubricate O-rings before assembly to allow the O-ring to seat itself properly.
- 4) Be certain to use torque wrenches when tightening O-ring fittings, because overtightening can not only damage the O-ring, but it can distort the tube end as well.

### B: REMOVE PROTECTIVE SEALS

- 1) Just prior to making the connection, remove the protective seals (A).

#### CAUTION:

**If for any reason you have to stop before making a connection, recap the tube, component or fitting.**

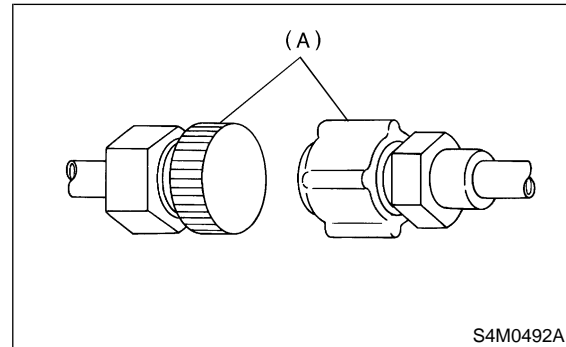

- 2) Visually inspect the O-ring surface, the O-ring mating surface, the threads and the connection points. If a defective part is found, replace it. The O-ring must sit square against the tube bead. If necessary, slide the O-ring into proper position with clean hands.

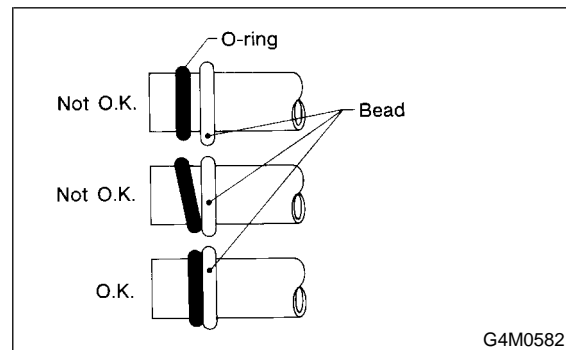



**C: LUBRICATE THE COMPONENTS**

For lubrication of the components, use only refrigerant oil as described in the appropriate service manual. Apply oil from an oil squirt gun or other closed container. Do not use your finger to spread the oil over the O-ring.

Apply a small amount of refrigerant oil to the top and sides of the O-ring. The area covered by oil should include the O-ring and the tube bead.

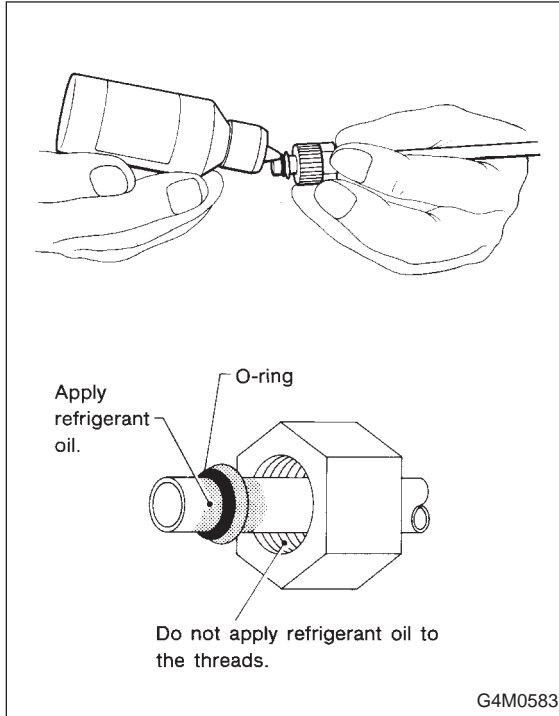
**D: TORQUE THE FITTING**

Using a back-up wrench in conjunction with a calibrated torque wrench (A), torque the connection to the midrange of the specification.

After completion of torquing, use a clean shop towel to remove any excess oil from the connection or any oil that may have dripped on the vehicle body or other parts.

**CAUTION:**

If a leak is suspected after torquing, do not retighten or retorque the connection. Instead, disassemble the connection, remove the O-ring, and inspect the O-ring, threads, joints and seating surfaces.

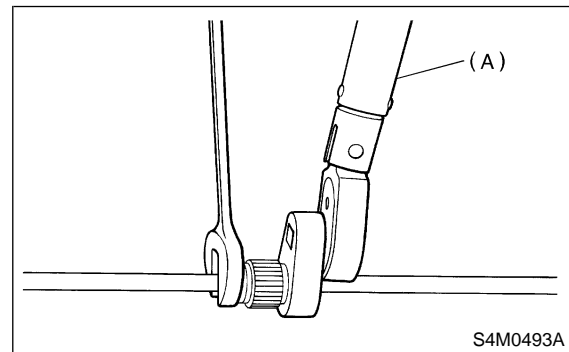

# 5. Refrigerant Service Procedure

## A: WORK FLOW

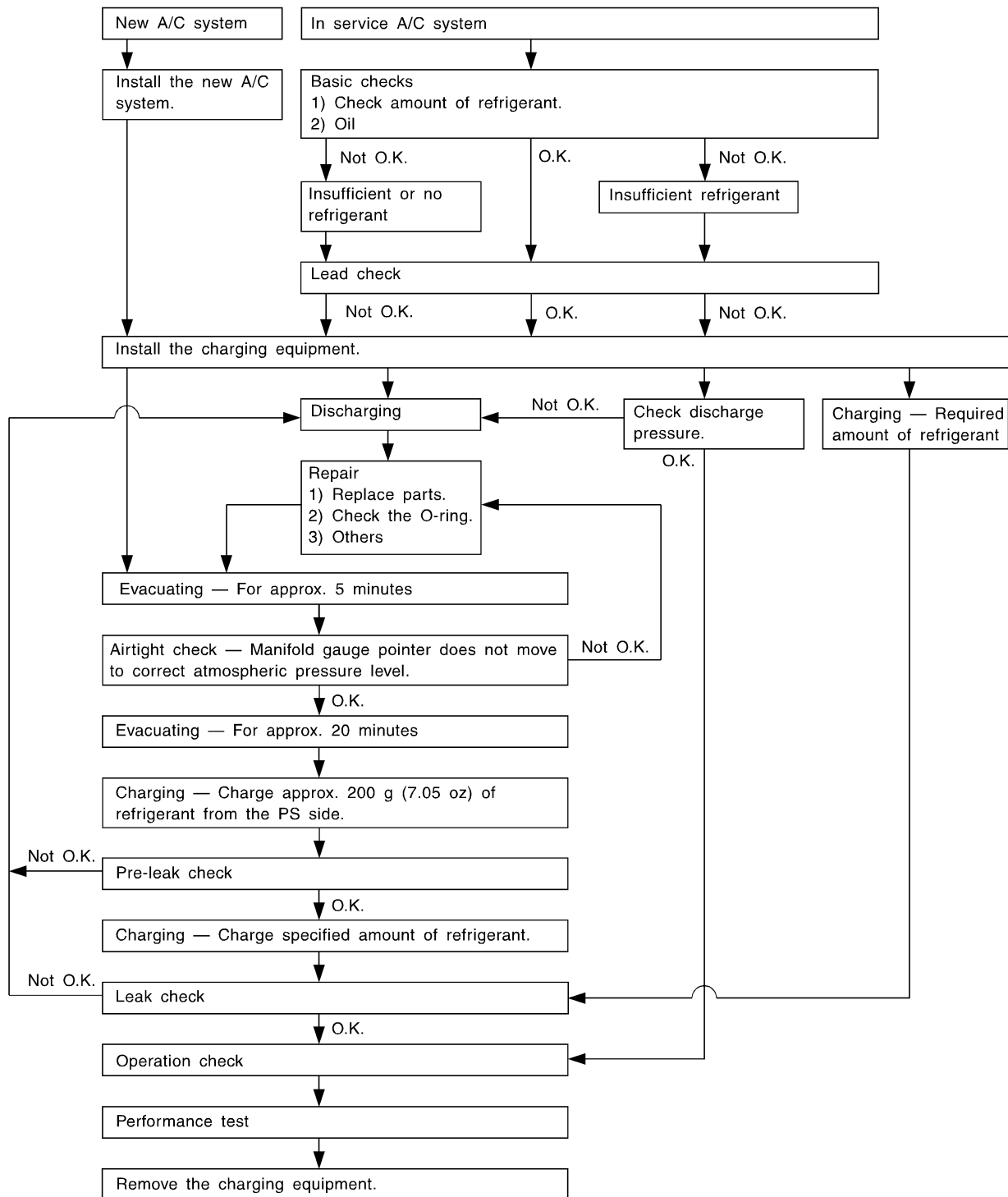

## 6. Discharge the System

### CAUTION:

The following points must be kept in mind when discharging the system.

- Be certain that goggles and gloves are worn.
- Connect refrigerant recovery system to manifold gauge set and remove recycled refrigerant from the A/C system.

### NOTE:

Refer to the relevant refrigerant recovery system instruction manual for operating procedures.

### A: CONNECTING THE MANIFOLD GAUGE SET

- 1) Close the high and low side manifold valves.

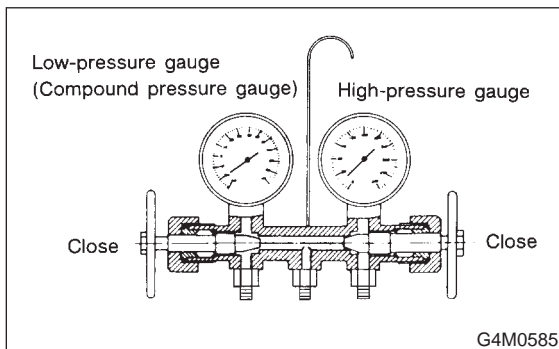

- 2) Turn the A/C system ON and turn the IG switch OFF.
- 3) Attach the high- and low-pressure manifolds to the high and low services port on the vehicle.

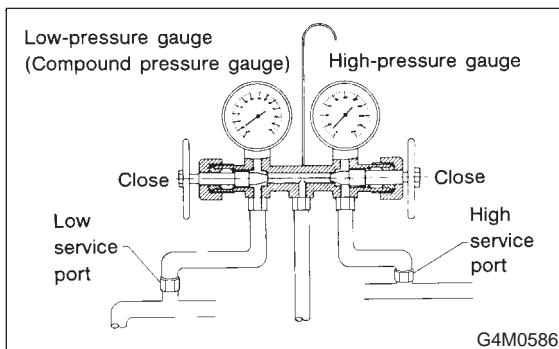

### B: PREPARE FOR DISCHARGING

Connect center manifold hose to refrigerant recovery system to recycle refrigerant.

## 7. Evacuating and Charging

The following points should be kept in mind when evacuating and charging with a manifold gauge set:

- 1) Be certain that goggles and gloves are worn.
- 2) If bulk refrigerant [13.6 kg (30 lb) canister] is used, be certain to weigh the charge amount carefully, using the correct equipment, to avoid overcharging the system.
- 3) The charging procedure described in this section begins by charging liquid refrigerant into the high-pressure side of the system with the engine off. The procedure is completed by charging refrigerant vapor into the low-pressure side of the system with the engine running.

### CAUTION:

Never open the high-pressure manifold valve when the engine is running.

### A: CONNECT THE GAUGE SET

- 1) Close the high- and low-pressure manifold valves.

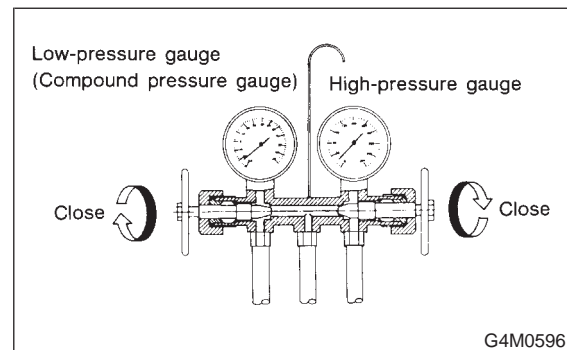

- 2) Attach the low-pressure manifold hose to the low-pressure service port on the vehicle. Check the low-pressure gauge. If more than 68.6 kPa (0.70 kg/cm<sup>2</sup>, 10 psi) is indicated, discharge the system prior to charging.
- 3) Attach the high-pressure manifold hose to the high-pressure service port on the vehicle.
- 4) Connect the center hose from the manifold to the vacuum pump.
- 5) Turn on the vacuum pump.

## 6. Discharge the System

### CAUTION:

The following points must be kept in mind when discharging the system.

- Be certain that goggles and gloves are worn.
- Connect refrigerant recovery system to manifold gauge set and remove recycled refrigerant from the A/C system.

### NOTE:

Refer to the relevant refrigerant recovery system instruction manual for operating procedures.

### A: CONNECTING THE MANIFOLD GAUGE SET

- 1) Close the high and low side manifold valves.

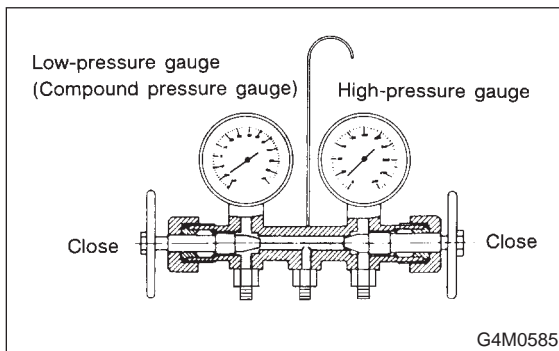

- 2) Turn the A/C system ON and turn the IG switch OFF.

- 3) Attach the high- and low-pressure manifolds to the high and low services port on the vehicle.

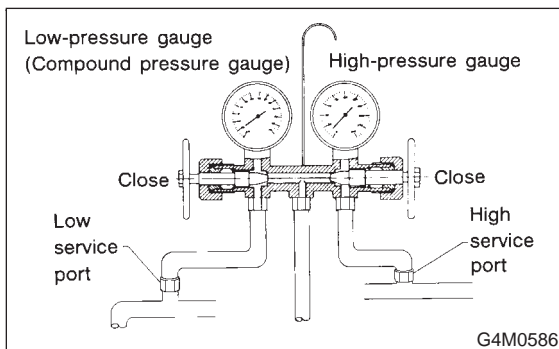

### B: PREPARE FOR DISCHARGING

Connect center manifold hose to refrigerant recovery system to recycle refrigerant.

## 7. Evacuating and Charging

The following points should be kept in mind when evacuating and charging with a manifold gauge set:

- 1) Be certain that goggles and gloves are worn.
- 2) If bulk refrigerant [13.6 kg (30 lb) canister] is used, be certain to weigh the charge amount carefully, using the correct equipment, to avoid overcharging the system.
- 3) The charging procedure described in this section begins by charging liquid refrigerant into the high-pressure side of the system with the engine off. The procedure is completed by charging refrigerant vapor into the low-pressure side of the system with the engine running.

### CAUTION:

Never open the high-pressure manifold valve when the engine is running.

### A: CONNECT THE GAUGE SET

- 1) Close the high- and low-pressure manifold valves.

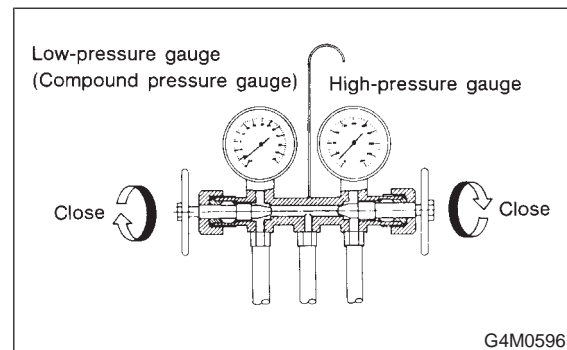

- 2) Attach the low-pressure manifold hose to the low-pressure service port on the vehicle. Check the low-pressure gauge. If more than 68.6 kPa (0.70 kg/cm<sup>2</sup>, 10 psi) is indicated, discharge the system prior to charging.

- 3) Attach the high-pressure manifold hose to the high-pressure service port on the vehicle.

- 4) Connect the center hose from the manifold to the vacuum pump.

- 5) Turn on the vacuum pump.

6) Slowly open the low-pressure manifold valve.

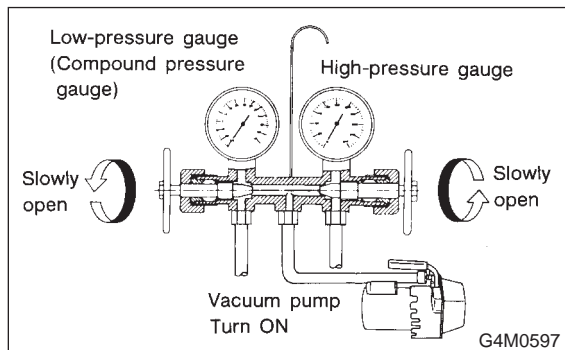

4) Note the low side gauge reading.

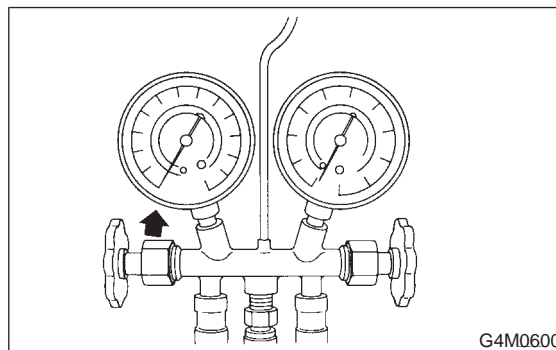

7) When the low-pressure gauge reaches approximately 66.43 kPa (498.3 mmHg, 19.62 inHg), slowly open the high-pressure manifold valve.

8) Maintain a minimum vacuum level of 100.56 kPa (754.4 mmHg, 29.70 inHg) for a minimum of 15 minutes on a new system or 30 minutes for an in-service system.

**NOTE:**

The gauge will read 3.3 kPa (25 mmHg, 1 inHg) less for every 304.8 m (1,000 ft) above sea level.

5) After 5 minutes, re-check the low-pressure gauge reading.

If the vacuum level has changed more than 3.3 kPa (25 mmHg, 1 inHg), perform an HFC-134a leak test.

If the vacuum reading is about the same as noted in step 4), continue on to next step.

6) Carefully attach the can tap to the refrigerant can by following the can tap manufacturer's instructions.

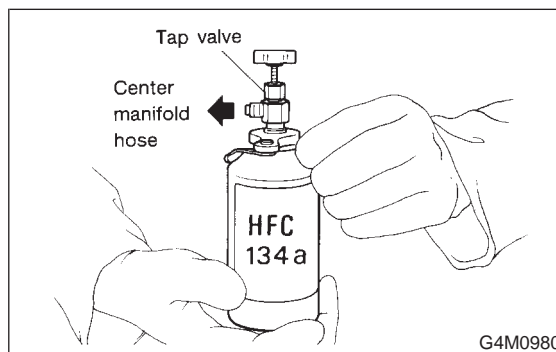
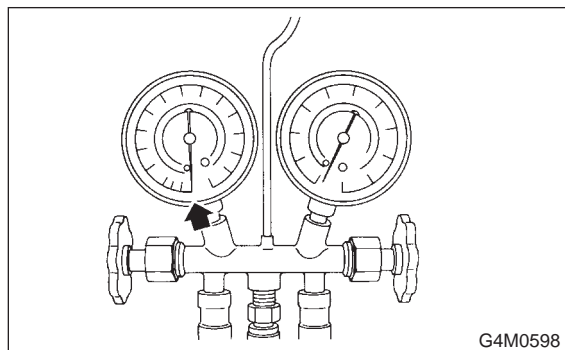

**B: PERFORM A VACUUM LEAK TEST**

- 1) After 15 minutes (or more) of evacuation, close the high-pressure manifold valve.
- 2) Close the low-pressure manifold valve.

7) Disconnect the center manifold hose from the vacuum pump and connect the hose to the tap valve.

8) If a 13.6 kg (30 lb) container of refrigerant is used a weight scale will be needed. This scale is to determine the amount of refrigerant that is used. Connect the center hose from the manifold to the valve. Place the 13.6 kg (30 lb) container on the scale, valve end down.

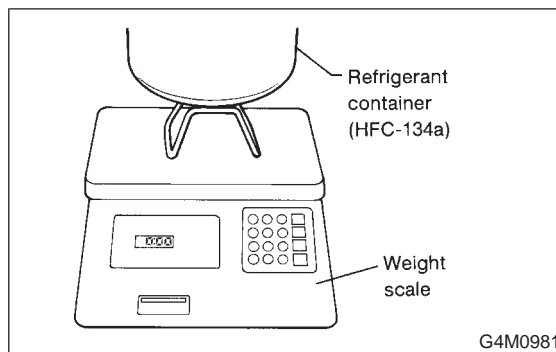
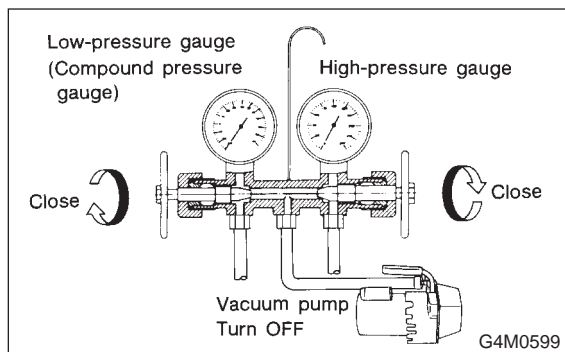

3) Turn off the vacuum pump.

**C: PURGE THE CENTER HOSE****CAUTION:**

Be certain that goggles and gloves are worn.

- 1) Verify that all three hose connections are tight at the manifold gauge set.

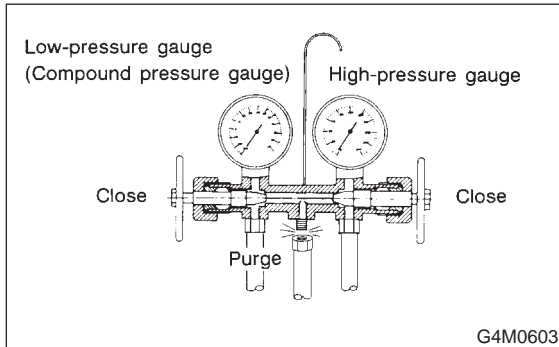

- 2) Open the valve on the HFC-134a source.
- 3) Loosen the center hose connection at the manifold and allow the HFC-134a to escape for no more than two or three seconds, then quickly retighten the hose fitting at the manifold.

**D: INITIAL CHARGING THROUGH THE HIGH SIDE**

- 1) Connect a tachometer to the engine.
- 2) With the engine off, start charging by slowly opening the high-pressure manifold valve.

**NOTE:**

The initial charge rate can be increased by immersing the can in lukewarm [Below 38°C (100°F)] water for a short time.

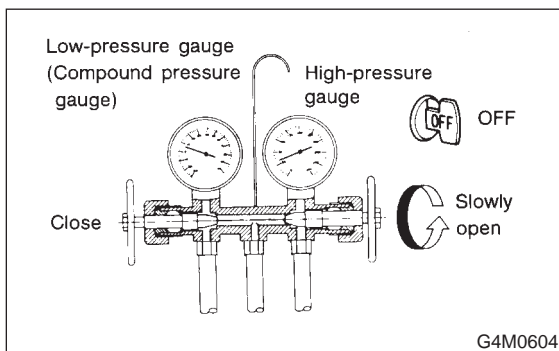
**E: CHECK THE GAUGE READINGS**

When both the high- and low-pressure gauge readings are about equal, or the HFC-134a source is empty, or the system has been filled to specifications, close the high-pressure manifold valve.

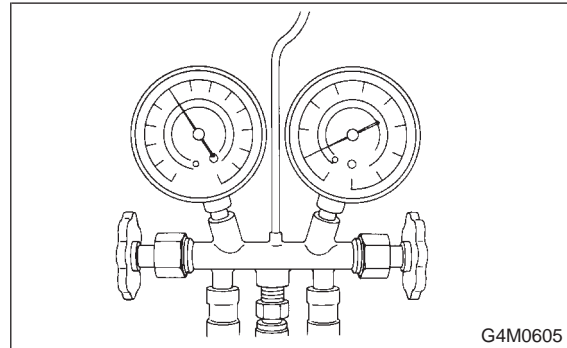
**F: ADD ADDITIONAL CANS**

If the HFC-134a source is exhausted, first close the high-pressure manifold valve, second, close the can tap valve, then slowly purge the refrigerant from the service hose by loosening the fitting at the can tap.

**G: COMPLETE CHARGING THROUGH THE LOW SIDE**

- 1) Verify that the high-pressure manifold valve is closed (should have already been closed).
- 2) Verify that the low-pressure manifold valve is closed (should have already been closed).

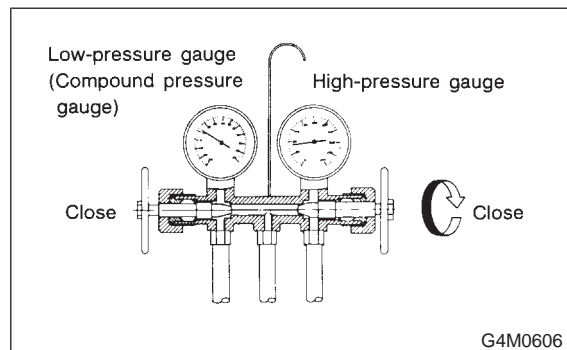

- 3) With the A/C switch off and the windows rolled down, start the engine and run at idle rpm.
- 4) Set the A/C controls on maximum cool and set the blower speed on the highest setting.

5) Quickly turn the A/C switch on-off-on-off a few times to prevent initial compressor damage due to "load shock". Finish this operation with the A/C switch in the ON position.

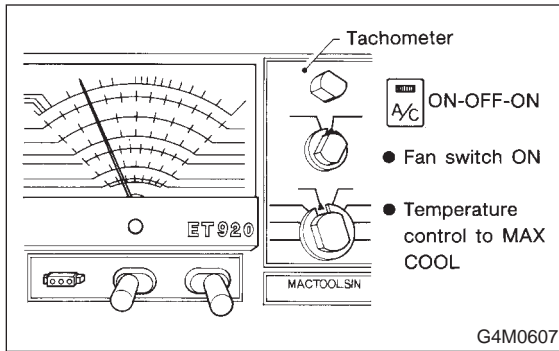

6) Raise engine rpm to approximately 1,500 rpm.

**H: CHARGE THE SYSTEM**

1) With the refrigerant source connected and the service hose purged, slowly open the low-pressure manifold valve, while checking the low-pressure gauge reading.

**CAUTION:**

The refrigerant source must be positioned for vapor (valve up).

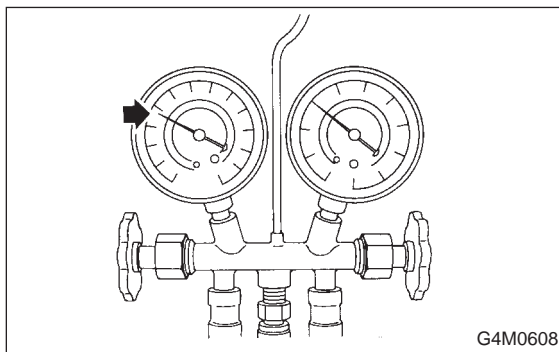

2) Keep the low side pressure below 276 kPa (2.81 kg/cm<sup>2</sup>, 40 psi) by using the low-pressure manifold valve to regulate the flow of refrigerant into the system.

3) When the system is fully charged, close the low-pressure manifold valve.

4) Close the valve at the refrigerant source.

Refrigerant capacity		
Refrigerant	Minimum	Maximum
HFC-134a	0.6 kg (1.3 lb)	0.7 kg (1.5 lb)

**I: COMPLETE ALL SYSTEM CHECKS**

1) Evaluate the system performance. <Ref. to 4-7 [K200].>

2) Perform leak detection test. <Ref. to 4-7 [W800].>

**CAUTION:**

Always perform leak checking in an environment free of refrigerant pollution.

Do not disconnect the high- or low-pressure hoses from the vehicle before leak checking.

**J: DISCONNECT THE MANIFOLD GAUGE SET**

1) Remove the high- or low-pressure hoses from the service ports and install the service port caps.

## 8. Leak Testing

### A: INSPECTION

The following points should be kept in mind when conducting a refrigerant leak test.

- 1) The A/C system to be tested must have an adequate refrigerant charge to begin with.
- 2) The area where the leak test is conducted must be free of wind and drafts, with still air being the ideal condition.
- 3) The atmosphere where the leak test is conducted must be free of refrigerant contamination.
- 4) Operate the A/C system for approx. 10 minutes, then turn the engine off and begin the leak test.
- 5) Refrigerant gas is heavier than air, therefore always hold the probe below the connection being tested.
- 6) When checking for a leak along a length of hose or tube, the leak detector probe must be moved slowly, approx. 25 mm (1 in) per second making sure probe does not come in contact with the component being tested.
- 7) When checking for a leak at a certain point, the leak detector probe must be held at that point for at least 5 seconds.

#### 1. CHECK THE SYSTEM PRESSURE

With gauges connected to the A/C system, operate the A/C and confirm that the high side pressure is above 690 kPa (7.03 kg/cm<sup>2</sup>, 100 psi). If not, evacuate and charge the system before leak checking. <Ref. to 4-7 [W700].>

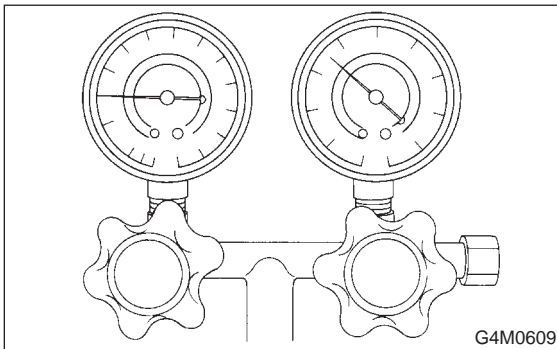

#### 2. CLEAN CONNECTIONS BEFORE TESTING

Before testing, use a clean shop towel to wipe off refrigerant oil, dirt, or foreign material from all of the connections and components to be tested.

#### NOTE:

Since refrigerant oil absorbs refrigerant, excess oil on or near a connection may falsely signal a leak.

#### 3. CALIBRATE LEAK DETECTOR

Refer to the manufacturer's instructions for the particular type of detector used and calibrate the instrument.

#### CAUTION:

**Always make sure that the probe tip filter is clean and free of contamination.**

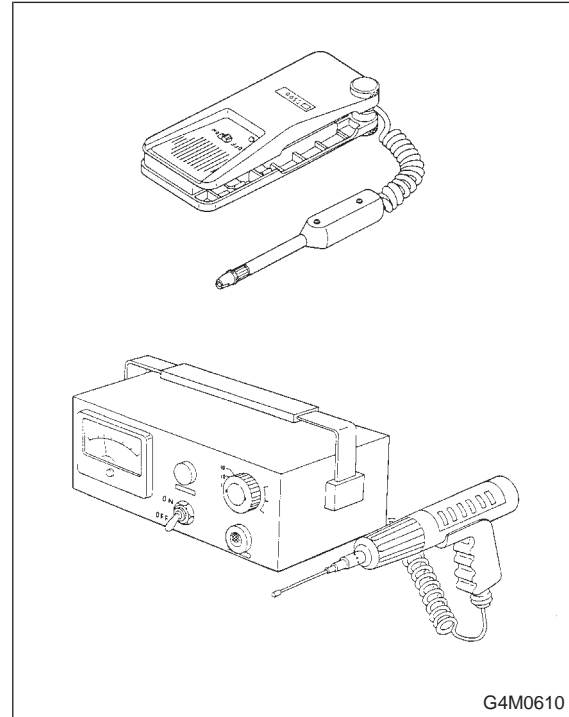

#### 4. LEAK TEST — HIGH-PRESSURE SIDE

Operate the A/C system for approx. 10 minutes, then turn the engine off and begin the leak test.

- 1) Begin at the connection of the high-pressure tube to the evaporator, and work your way along the high-pressure side of the system to the compressor. There are three places to check each tube connection.
- 2) Check the area:
  - Check the area where the fitting meets the tube.

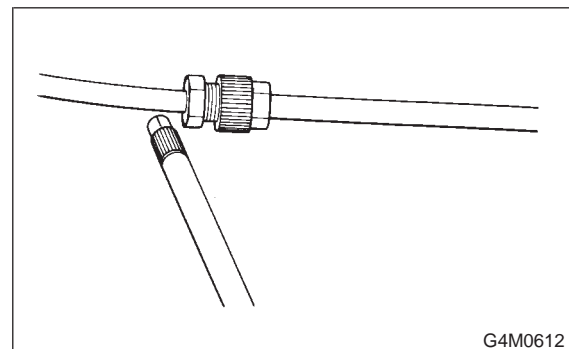



- Check the area where the two parts of the fitting join each other.

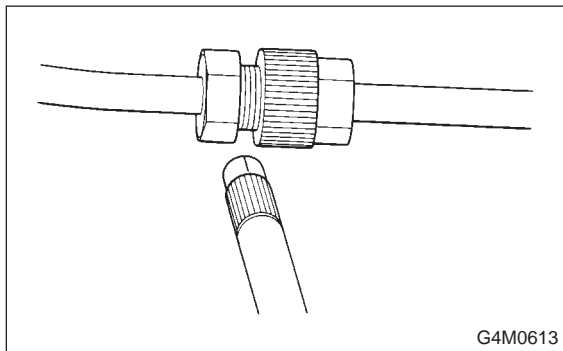

- Check the area where the nut meets the tube.

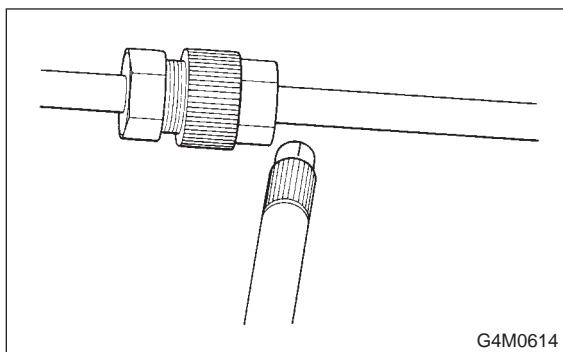

- 3) Check the area of the pressure switch (dual switch), and also check the seams of the receiver drier.
- 4) Check the connections of the tubes to the condenser, and also check any welded joints on the condenser.

**CAUTION:**

**An oily area on the fins of the condenser may indicate a leak.**

- 5) Check the area where the hoses attach to the compressor.
- 6) Check around the machined portions of the compressor (where the compressor sections join each other).
- 7) If equipped, check the thermal limiter on the compressor housing.
- 8) Check the compressor shaft seal by probing near the center of the compressor clutch pulley.

**NOTE:**

Some shaft seals have a very slight amount of normal leakage [approximately 28 g (1.0 oz) per year].

**5. LEAK TEST — LOW-PRESSURE SIDE**

- 1) Begin at the connection of the low-pressure tube to the evaporator, and work your way along the low-pressure of the system to the compressor. There are three places to check on each tube connection.
- 2) Check the area:
  - (1) Check the area where the fitting joins the tube.
  - (2) Check the area where the two parts of the fitting join each other.

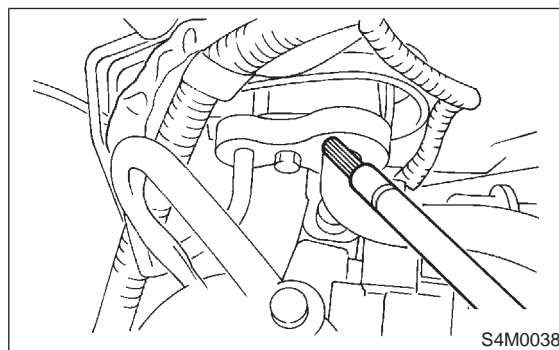

**6. CHECK THE FLEXIBLE HOSES**

- 1) Visually inspect the rubber portions of the flexible hoses for cracking. Probe the rubber section, including the ends of any insulators or protectors which may cover sections of the rubber hose, and near the ends where the rubber meets the metal collar.

**NOTE:**

Be certain to move the probe slowly [approximately 25 mm (1 in) per second] when probing along any length of hose or tube.

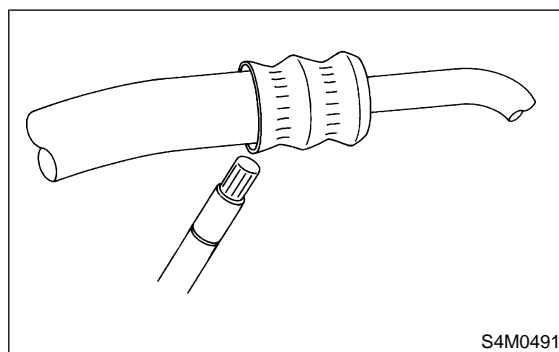

## 7. CHECK THE EVAPORATOR ASSEMBLY

- 1) Use one or both of the following methods to check the evaporator assembly.
- 2) Remove the drain hose from the case drain nipple. Hold the probe at the end of the case drain nipple for at least 10 seconds. Be certain to reconnect the drain hose when finished.
- 3) With the ignition key in the "ACC" position, run the blower on high speed for 1 minute, then turn the blower off. Place the probe in the center instrument panel vent, and turn the blower on low speed for 1 to 2 seconds, then turn the blower off. Leave the probe in the vent for at least 10 seconds.

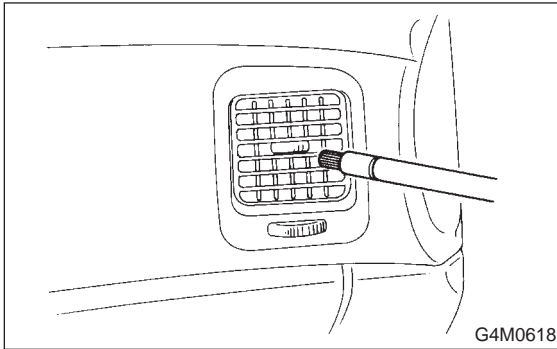

## 8. CHECK THE SERVICE PORT CAPS

Visually inspect the inside of the service port caps. Make sure the rubber seal is in place on the inside of the caps. Disconnect the gauges from the vehicle and install the service port caps.

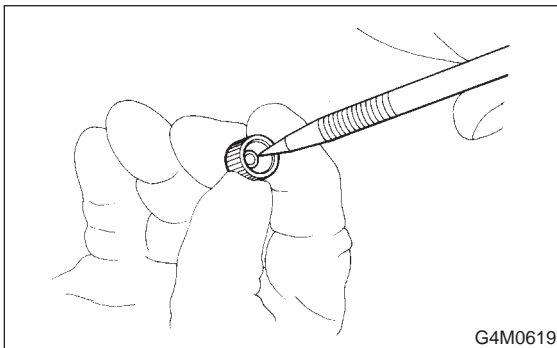

## 9. Lubrication

### A: ADJUSTMENT

#### 1. SYSTEM OIL STABILIZATION

- 1) Prior to opening the refrigerant system for repairs (except compressor seizure) the system must be stabilized for correct oil replenishment.
- 2) Follow these procedures:
  - (1) Engine speed set to 1,500 rpm
  - (2) A/C "ON"
  - (3) Air source to recirculate
  - (4) Blower 4th or high speed position
  - Make sure the air entering the evaporator is above 26.7°C (80°F).
  - The discharge (high) side pressure must be above 588 kPa (6 kg/cm<sup>2</sup>, 85 psi).
  - (5) Operate the A/C for 10 minutes.

#### 2. SYSTEM DISCHARGE

Slowly, discharge the system starting with the high-pressure side until the pressure drops below 345 kPa (3.52 kg/cm<sup>2</sup>, 50 psi), then open the low-pressure side.

### B: REPLACEMENT

#### 1. OIL REPLACEMENT

- 1) After stabilization and discharge, replace the component, adding the appropriate amount of oil (ZXL200PG) to the new component before installation.

Evaporator	70 ml (2.4 US fl oz, 2.5 Imp fl oz)
Receiver drier	5 ml (0.2 US fl oz, 0.2 Imp fl oz)
Condenser	50 ml (1.7 US fl oz, 1.8 Imp fl oz)
Hose	50 ml (1.7 US fl oz, 1.8 Imp fl oz)

- 2) If the compressor is replaced (after stabilization):
  - (1) Drain and measure the oil from the original compressor.
  - (2) Drain the oil from the replacement compressor and refill with the same amount that was drained from the original [20 ml (0.7 US fl oz, 0.7 Imp fl oz) minimum]. Always use ZXL200PG for the replacement oil.

## 7. CHECK THE EVAPORATOR ASSEMBLY

- 1) Use one or both of the following methods to check the evaporator assembly.
- 2) Remove the drain hose from the case drain nipple. Hold the probe at the end of the case drain nipple for at least 10 seconds. Be certain to reconnect the drain hose when finished.
- 3) With the ignition key in the "ACC" position, run the blower on high speed for 1 minute, then turn the blower off. Place the probe in the center instrument panel vent, and turn the blower on low speed for 1 to 2 seconds, then turn the blower off. Leave the probe in the vent for at least 10 seconds.

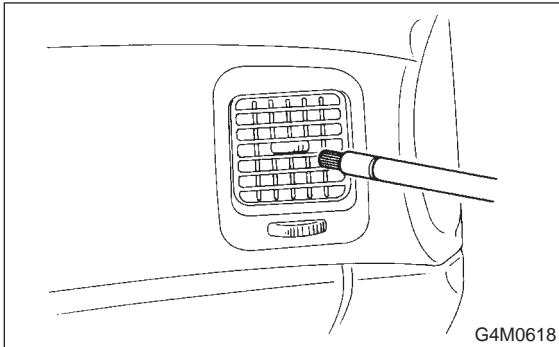

## 8. CHECK THE SERVICE PORT CAPS

Visually inspect the inside of the service port caps. Make sure the rubber seal is in place on the inside of the caps. Disconnect the gauges from the vehicle and install the service port caps.

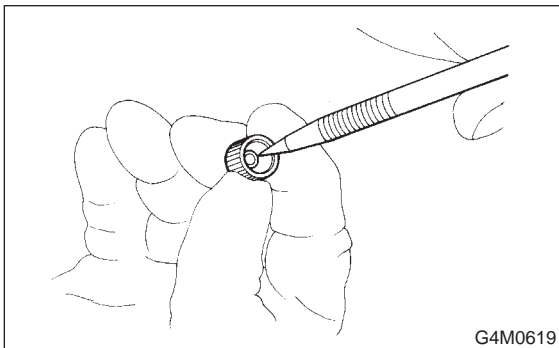

## 9. Lubrication

### A: ADJUSTMENT

#### 1. SYSTEM OIL STABILIZATION

- 1) Prior to opening the refrigerant system for repairs (except compressor seizure) the system must be stabilized for correct oil replenishment.
- 2) Follow these procedures:
  - (1) Engine speed set to 1,500 rpm
  - (2) A/C "ON"
  - (3) Air source to recirculate
  - (4) Blower 4th or high speed position
  - Make sure the air entering the evaporator is above 26.7°C (80°F).
  - The discharge (high) side pressure must be above 588 kPa (6 kg/cm<sup>2</sup>, 85 psi).
  - (5) Operate the A/C for 10 minutes.

#### 2. SYSTEM DISCHARGE

Slowly, discharge the system starting with the high-pressure side until the pressure drops below 345 kPa (3.52 kg/cm<sup>2</sup>, 50 psi), then open the low-pressure side.

### B: REPLACEMENT

#### 1. OIL REPLACEMENT

- 1) After stabilization and discharge, replace the component, adding the appropriate amount of oil (ZXL200PG) to the new component before installation.

Evaporator	70 ml (2.4 US fl oz, 2.5 Imp fl oz)
Receiver drier	5 ml (0.2 US fl oz, 0.2 Imp fl oz)
Condenser	50 ml (1.7 US fl oz, 1.8 Imp fl oz)
Hose	50 ml (1.7 US fl oz, 1.8 Imp fl oz)

- 2) If the compressor is replaced (after stabilization):
  - (1) Drain and measure the oil from the original compressor.
  - (2) Drain the oil from the replacement compressor and refill with the same amount that was drained from the original [20 ml (0.7 US fl oz, 0.7 Imp fl oz) minimum]. Always use ZXL200PG for the replacement oil.

## 10. Performance Test

### A: INSPECTION

#### 1. VEHICLE SET UP

In order to obtain meaningful test results, the vehicle must be set up to meet the following conditions:

- Vehicle in shade
- No wind
- All vehicle doors closed
- Front windows open
- Hood open
- Engine speed set at 1,500 rpm.
- A/C ON
- Temperature control lever — Maximum cold
- Air source — Recirculation
- Blower speed — 4th position (High)
- Operate A/C for 10 minutes (Minimum) before taking measurement.

#### 2. MEASUREMENTS

After 10 minutes (Minimum) of A/C operation and using accurate test equipment, take the following measurements (in order):

- 1) Evaporator intake air temperature at recirculation door.
- 2) Evaporator discharge air temperature at center grill.
- 3) Condenser (Ambient) intake air temperature measured 0.9 m (3 ft) in front and in line with the center of the condenser
- 4) Suction (Low) side pressure
- 5) Discharge (High) side pressure

#### NOTE:

If only one thermometer is available; 1) take the ambient measurement first; then 2) the intake air; and 3) discharge air temperature.

## 11. Compressor

### A: INSPECTION

#### 1. COMPRESSOR CLUTCH

#### NOTE:

Compressor clutch trouble is often caused by clutch slippage and noise. Check and take corrective measures, as required.

- 1) Remove belt cover.

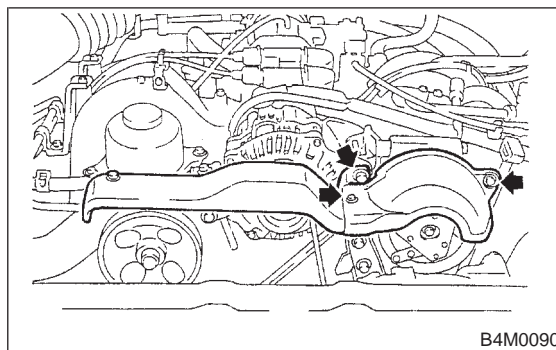

- 2) Check that clearance between drive plate and pulley over the entire perimeter is within specifications.

#### Clearance:

**$0.45 \pm 0.15$  mm ( $0.0177 \pm 0.0059$  in)**

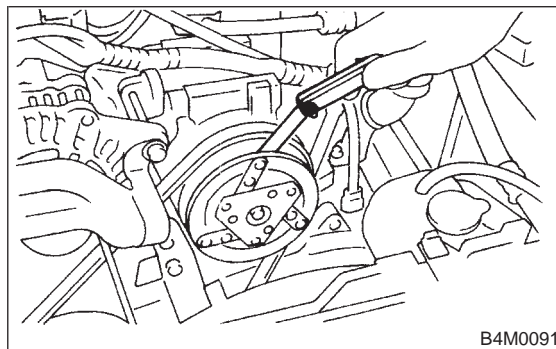

- 3) Check that voltage applied to magnetic coil is at least 10.5 volts.
- 4) When noise is noted, check that it originates in either compressor or pulley bearing.

## 10. Performance Test

### A: INSPECTION

#### 1. VEHICLE SET UP

In order to obtain meaningful test results, the vehicle must be set up to meet the following conditions:

- Vehicle in shade
- No wind
- All vehicle doors closed
- Front windows open
- Hood open
- Engine speed set at 1,500 rpm.
- A/C ON
- Temperature control lever — Maximum cold
- Air source — Recirculation
- Blower speed — 4th position (High)
- Operate A/C for 10 minutes (Minimum) before taking measurement.

#### 2. MEASUREMENTS

After 10 minutes (Minimum) of A/C operation and using accurate test equipment, take the following measurements (in order):

- 1) Evaporator intake air temperature at recirculation door.
- 2) Evaporator discharge air temperature at center grill.
- 3) Condenser (Ambient) intake air temperature measured 0.9 m (3 ft) in front and in line with the center of the condenser
- 4) Suction (Low) side pressure
- 5) Discharge (High) side pressure

#### NOTE:

If only one thermometer is available; 1) take the ambient measurement first; then 2) the intake air; and 3) discharge air temperature.

## 11. Compressor

### A: INSPECTION

#### 1. COMPRESSOR CLUTCH

#### NOTE:

Compressor clutch trouble is often caused by clutch slippage and noise. Check and take corrective measures, as required.

- 1) Remove belt cover.

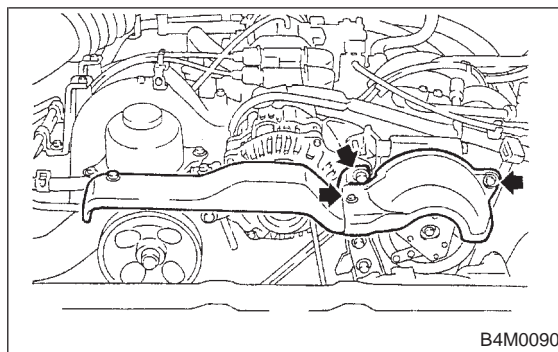

- 2) Check that clearance between drive plate and pulley over the entire perimeter is within specifications.

#### Clearance:

**$0.45 \pm 0.15$  mm ( $0.0177 \pm 0.0059$  in)**

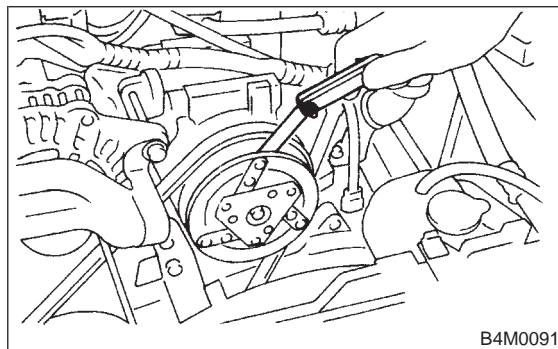

- 3) Check that voltage applied to magnetic coil is at least 10.5 volts.
- 4) When noise is noted, check that it originates in either compressor or pulley bearing.

**B: REMOVAL**

- 1) Disconnect ground cable from battery.
- 2) Discharge refrigerant using refrigerant recovery system. <Ref. to 4-7 [W600].>
  - (1) Fully close low-pressure valve of manifold gauge.
  - (2) Connect low-pressure charging hose of manifold gauge to low-pressure service valve.
  - (3) Open low-pressure manifold gauge valve slightly, and slowly discharge refrigerant from system.

**CAUTION:**  
Do not allow refrigerant to rush out. Otherwise, compressor oil will be discharged along with refrigerant.

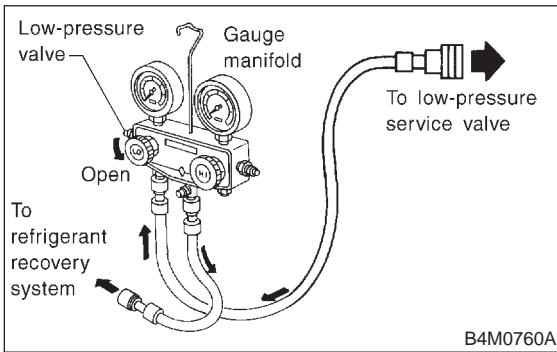

- 3) Remove low-pressure hose (A) and high-pressure hose (B).

**CAUTION:**

- Be careful not to lose O-ring of low-pressure hose.
- Plug the opening to prevent foreign matter from entering.

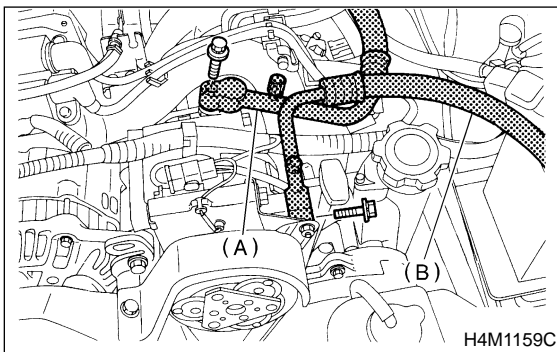

- 4) Compressor belt cover and generator belt cover:  
Remove bolts which secure belt covers.

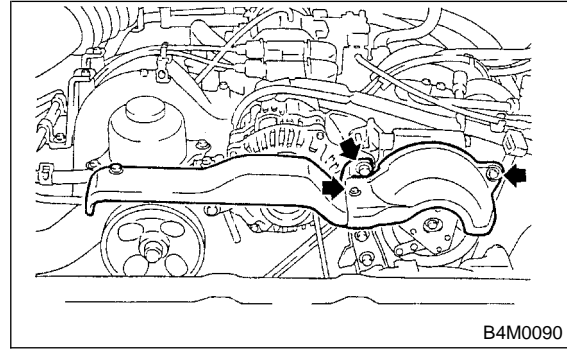

- 5) Remove generator V-belt:
  - (1) Loosen lock bolt (A) on generator bracket.
  - (2) Turn adjusting bolt (B) and remove V-belt.

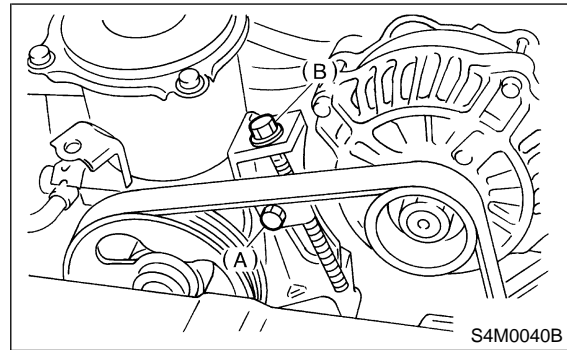

- 6) Remove compressor V-belt:
  - (1) Loosen lock nut (A) on idler pulley.
  - (2) Turn adjusting bolt (B) and remove V-belt.

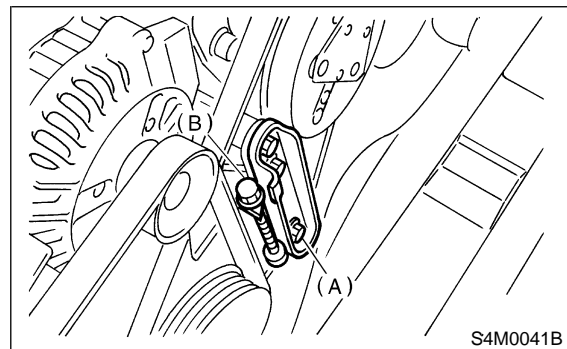

- 7) Disconnect generator harness.

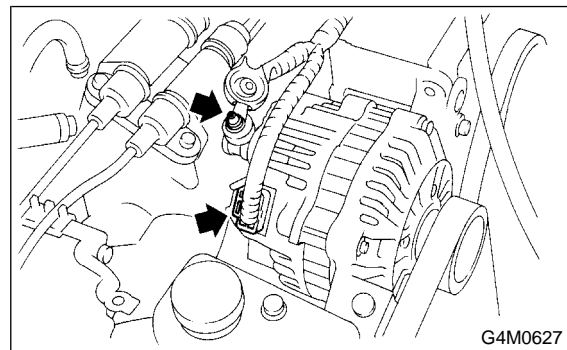

8) Disconnect compressor harness:  
Disconnect compressor harness from body harness.

9) Remove lower bracket:  
Remove bolts which secure lower compressor bracket.

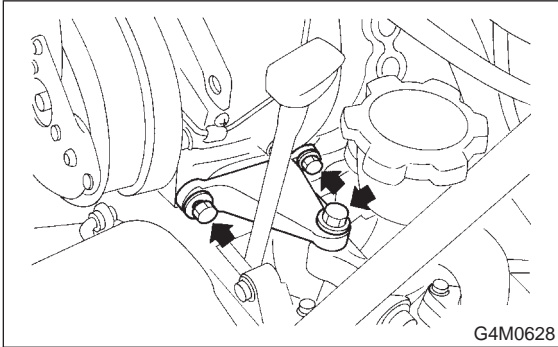

10) Remove compressor:  
(1) Remove bolts which secure compressor.  
(2) Remove compressor from bracket.

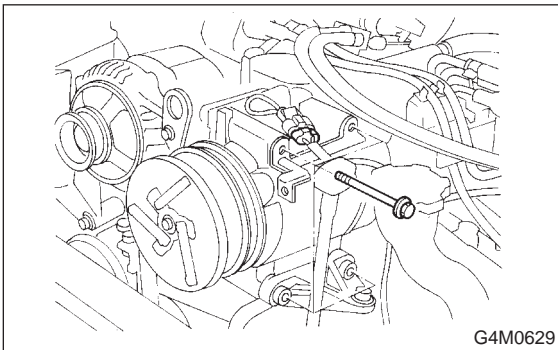

## C: INSTALLATION

1) Install compressor:  
Install compressor on bracket.

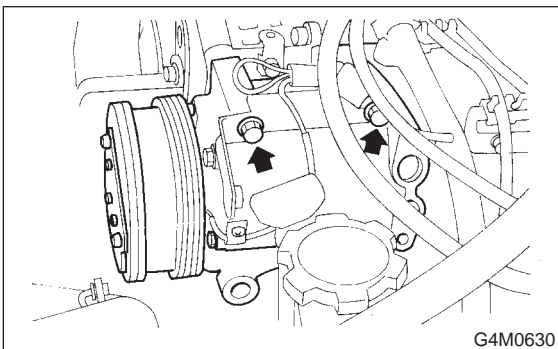

2) Install lower bracket.

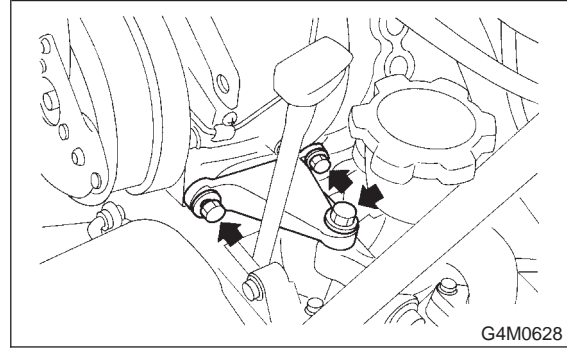

3) Connect compressor harness.  
4) Connect generator harness.  
5) Install compressor V-belt (Rear):  
After adjusting belt tension, tighten tension pulley lock nut (A) securely.

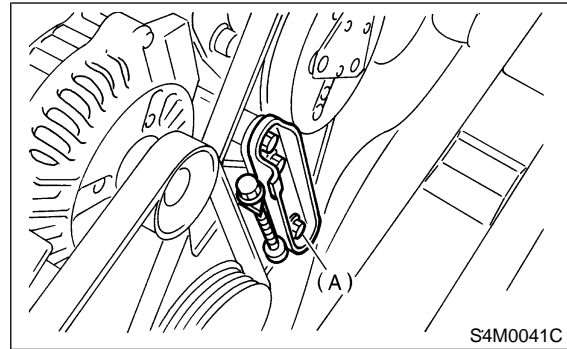

6) Install generator V-belt:  
After adjusting V-belt tension, tighten generator bracket lock bolt (A) securely.

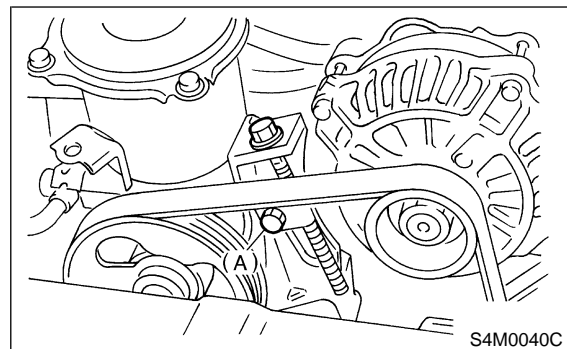

7) Check drive belt tension and adjust it if necessary by changing generator position and/or idler pulley position.

**CAUTION:**

- Ensure that the V-belt is aligned correctly. If it is not, check for loose bolts.

- The V-belt should not be too tight or too loose.

A belt which is too tight may break bearing or cause gas to leak from the shaft seal. A belt which is too loose slips, thereby causing the belt cut.

- After completing the compressor installation and testing the system operation, check and adjust the tension of both V-belts again.

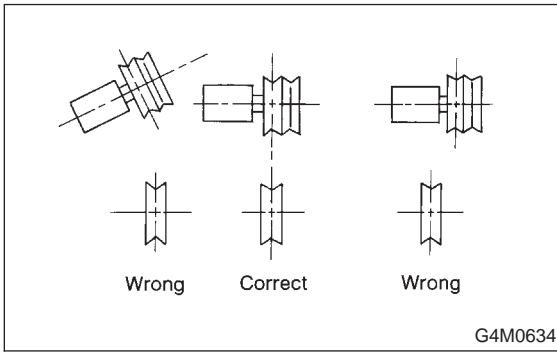

Pulley arrangement	Tension mm (in)/98 N (10 kg, 22 lb)	
	(A)	(B)
<p>Figures in table refer to the number of grooves in pulleys. C/P: Crankshaft pulley GEN: Generator pulley P/S: Power steering oil pump pulley A/C: Air conditioning compressor pulley I/P: Idler pulley</p>	<p>*New belt: 7.0 – 9.0 (0.276 – 0.354) Existing belt: 9.0 – 11.0 (0.354 – 0.433)</p>	<p>*New belt: 7.5 – 8.5 (0.295 – 0.335) Existing belt: 9.0 – 10.0 (0.354 – 0.394)</p>
<p>*When replacing belts with new ones, adjust tensions to specification and then readjust to the same specification after running engine for 5 minutes.</p>		

B4M1098B



8) Install high-pressure hose (B) and low-pressure hose (A).

**CAUTION:**

**Be sure to apply compressor oil to the periphery of O-ring.**

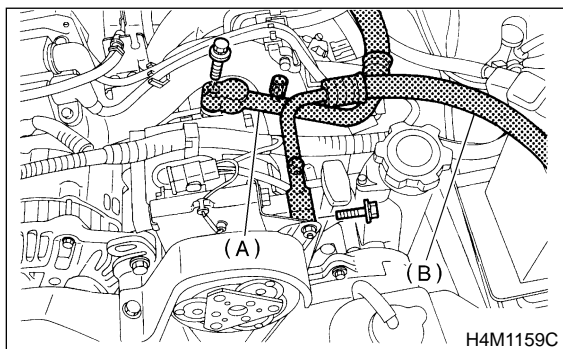

9) Install belt cover.

**CAUTION:**

- After installing belt cover, make sure it is not misaligned or twisted.
- After installing belt cover, check the clearance between pulley and belt cover.

10) Connect ground cable to negative terminal of battery.

11) Charging refrigerant. <Ref. to 4-7 [W700].>

## 12. Condenser

### A: REMOVAL AND INSTALLATION

- 1) Disconnect battery negative terminal.
- 2) Discharge refrigerant using refrigerant recovery system. <Ref. to 4-7 [W600].>
- 3) Remove front grille. <Ref. to 5-1 [W12A0].>
- 4) Disconnect high-pressure hose (A) and high-pressure pipe (B) from condenser.

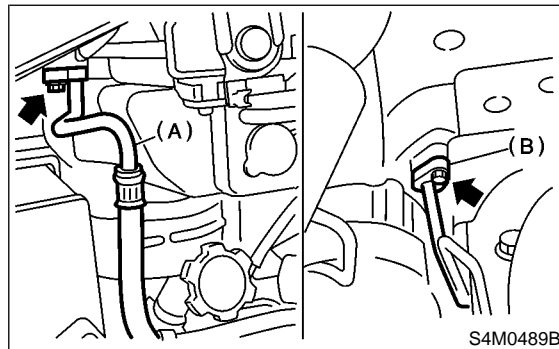

- 5) Remove the radiator bracket (A) and then remove the two bolts which secure condenser. While lifting condenser, remove it through space between radiator and radiator panel.

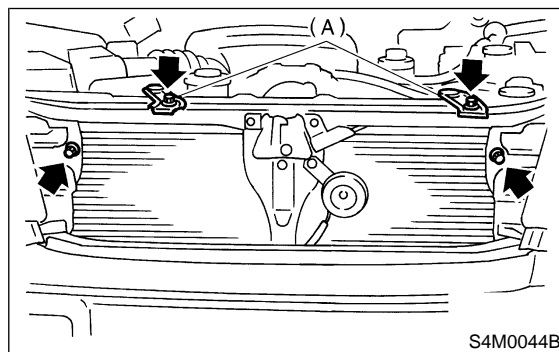

8) Install high-pressure hose (B) and low-pressure hose (A).

**CAUTION:**

**Be sure to apply compressor oil to the periphery of O-ring.**

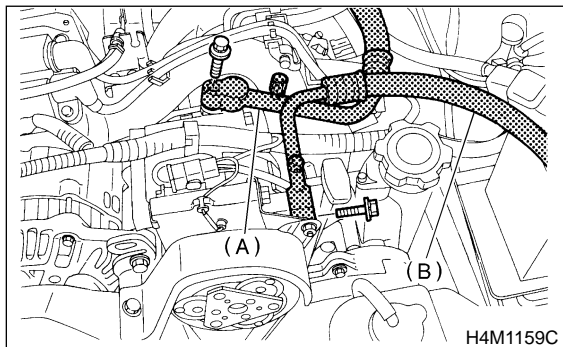

9) Install belt cover.

**CAUTION:**

- After installing belt cover, make sure it is not misaligned or twisted.
- After installing belt cover, check the clearance between pulley and belt cover.

10) Connect ground cable to negative terminal of battery.

11) Charging refrigerant. <Ref. to 4-7 [W700].>

## 12. Condenser

### A: REMOVAL AND INSTALLATION

- 1) Disconnect battery negative terminal.
- 2) Discharge refrigerant using refrigerant recovery system. <Ref. to 4-7 [W600].>
- 3) Remove front grille. <Ref. to 5-1 [W12A0].>
- 4) Disconnect high-pressure hose (A) and high-pressure pipe (B) from condenser.

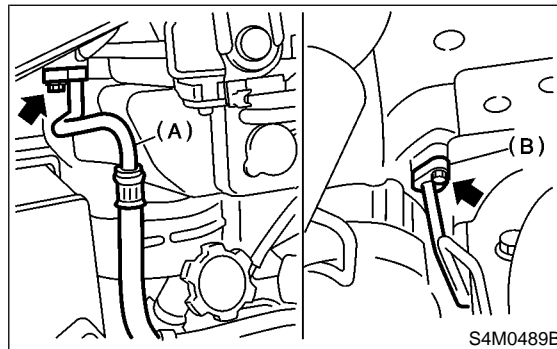

- 5) Remove the radiator bracket (A) and then remove the two bolts which secure condenser. While lifting condenser, remove it through space between radiator and radiator panel.

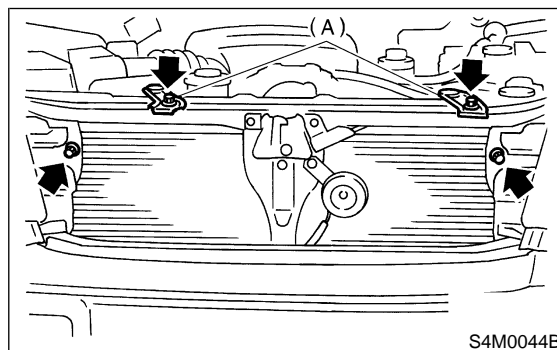

6) The condenser should be installed in the reverse order in which it was removed.

When installing the condenser, pay attention to the following:

**CAUTION:**

**Before connecting the pipe, be sure to apply oil to the periphery of O-ring.**

**NOTE:**

After installing condenser, ensure that guide (A) on lower side of condenser is inserted into hole in radiator panel (B). Tighten attaching bolts.

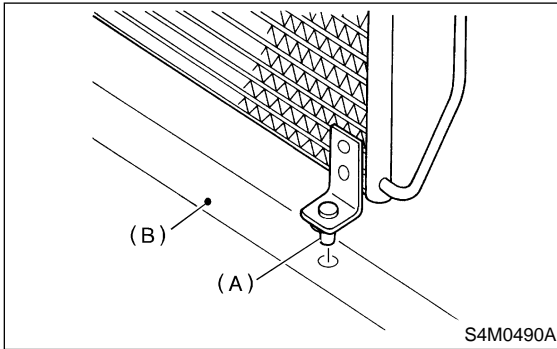

7) Charge refrigerant. <Ref. to 4-7 [W700].>

**B: INSPECTION**

1) Make sure the condenser fins are free from dust and insects. If the fins are clogged, clean by blowing air or water through them.

**NOTE:**

To prevent dust and water from getting into the condenser, this work must be done when the condenser is installed in an actual vehicle.

2) Check the condenser to see if it shows any sign of oil. Should oil ooze or gas leak from the condenser replace it with a new one.

**13. Receiver Drier**

**A: REMOVAL AND INSTALLATION**

- 1) Disconnect battery negative terminal.
- 2) Discharge refrigerant using refrigerant recovery system. <Ref. to 4-7 [W600].>
- 3) Disconnect pressure switch harness (A).
- 4) Disconnect pipes (B).
- 5) Remove mounting bolt (C) and remove receiver drier.

**CAUTION:**

**The receiver drier contains a desiccant. Be sure to put a blind plug in the detached receiver drier to protect it from moisture.**

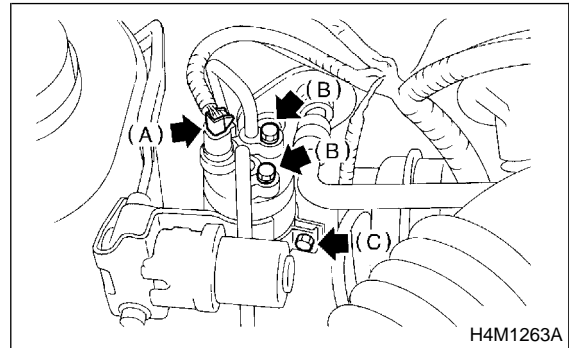

6) Install the receiver drier in the reverse order of removal.

7) Charge refrigerant. <Ref. to 4-7 [W700].>

6) The condenser should be installed in the reverse order in which it was removed.

When installing the condenser, pay attention to the following:

**CAUTION:**

**Before connecting the pipe, be sure to apply oil to the periphery of O-ring.**

**NOTE:**

After installing condenser, ensure that guide (A) on lower side of condenser is inserted into hole in radiator panel (B). Tighten attaching bolts.

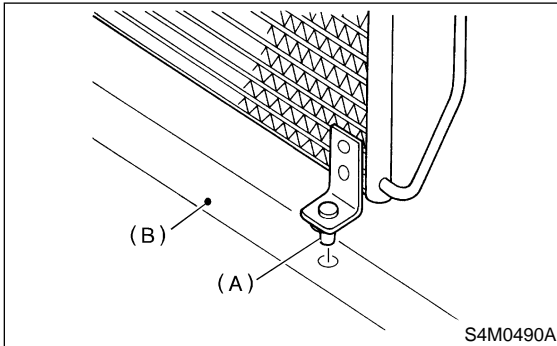

7) Charge refrigerant. <Ref. to 4-7 [W700].>

**B: INSPECTION**

1) Make sure the condenser fins are free from dust and insects. If the fins are clogged, clean by blowing air or water through them.

**NOTE:**

To prevent dust and water from getting into the condenser, this work must be done when the condenser is installed in an actual vehicle.

2) Check the condenser to see if it shows any sign of oil. Should oil ooze or gas leak from the condenser replace it with a new one.

**13. Receiver Drier**

**A: REMOVAL AND INSTALLATION**

- 1) Disconnect battery negative terminal.
- 2) Discharge refrigerant using refrigerant recovery system. <Ref. to 4-7 [W600].>
- 3) Disconnect pressure switch harness (A).
- 4) Disconnect pipes (B).
- 5) Remove mounting bolt (C) and remove receiver drier.

**CAUTION:**

**The receiver drier contains a desiccant. Be sure to put a blind plug in the detached receiver drier to protect it from moisture.**

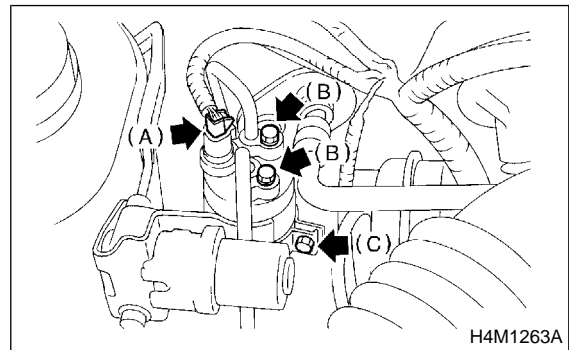

6) Install the receiver drier in the reverse order of removal.

7) Charge refrigerant. <Ref. to 4-7 [W700].>

## 14. Intake Unit with Evaporator

### A: REMOVAL AND INSTALLATION

- 1) Disconnect battery negative terminal.
- 2) Discharge refrigerant using refrigerant recovery system. <Ref. to 4-7 [W600].>
- 3) Remove bolt then disconnect discharge pipe and suction pipe.

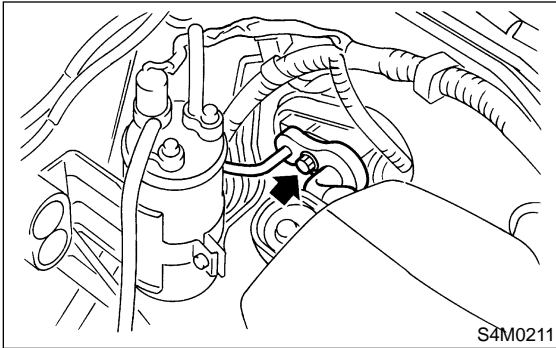

- 4) Remove glove box.

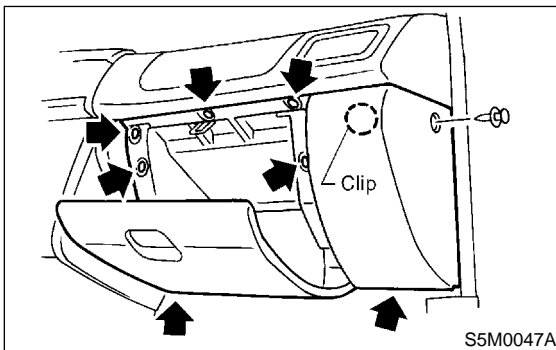

- 5) Disconnect the harness connector from intake unit.
- 6) Disconnect drain hose.
- 7) Remove intake unit mounting bolt and nut.

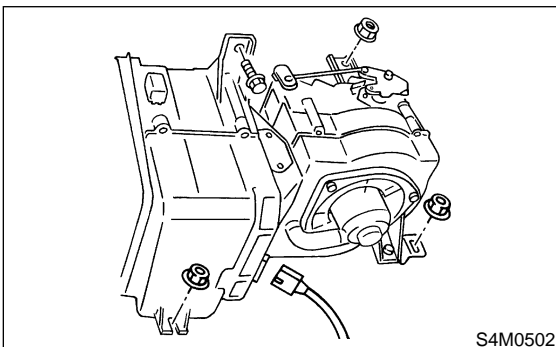

- 8) Install the intake unit in the reverse order of removal.
- 9) Charge refrigerant. <Ref. to 4-7 [W700].>

### B: DISASSEMBLY AND ASSEMBLY

- 1) Remove thermistor (A) from intake unit case.
- 2) Remove some screws then separate intake unit case.
- 3) Remove thermistor from clip with the evaporator.

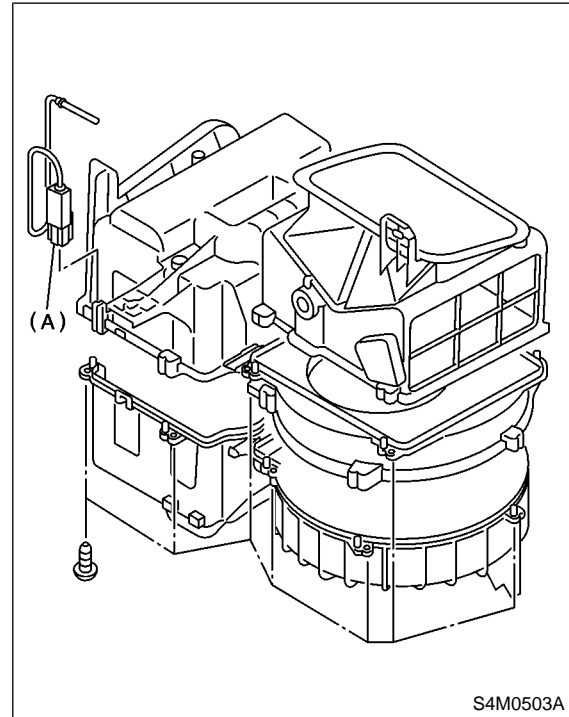

- 4) Remove the block expansion valve (A) from pipes.

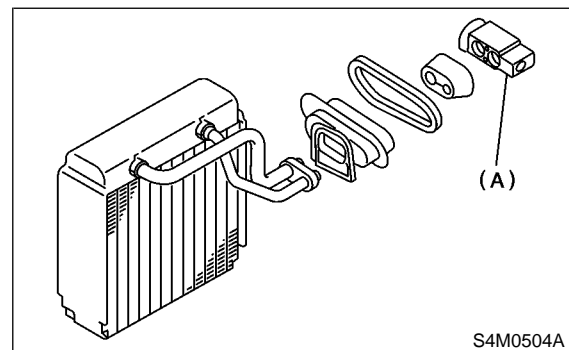

- 5) Check to see if the evaporator fins are clogged. If they are, clean them with compressed air.

**CAUTION:**  
Water must never be used to clean the evaporator.

- 6) Check parts that have been removed for cracks or scratches, and repair or replace them with new ones, if necessary.
- 7) Reassemble the intake unit in the reverse order of disassembly.

## NOTE:

Confirm that the O-ring is inserted in the specified position.

## 15. Condenser Fan Assembly

### A: REMOVAL AND INSTALLATION

- 1) Disconnect battery negative terminal.
- 2) Disconnect harness connector from fan motor.
- 3) Remove condenser fan bolt from radiator.

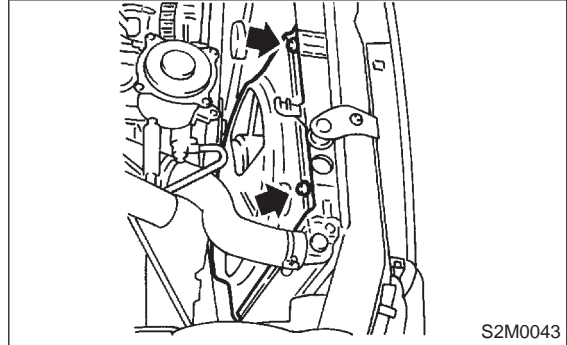

- 4) Pull condenser fan assembly.
- 5) Install the condenser fan assembly in the reverse order of removal.

## NOTE:

Confirm that the O-ring is inserted in the specified position.

## 15. Condenser Fan Assembly

### A: REMOVAL AND INSTALLATION

- 1) Disconnect battery negative terminal.
- 2) Disconnect harness connector from fan motor.
- 3) Remove condenser fan bolt from radiator.

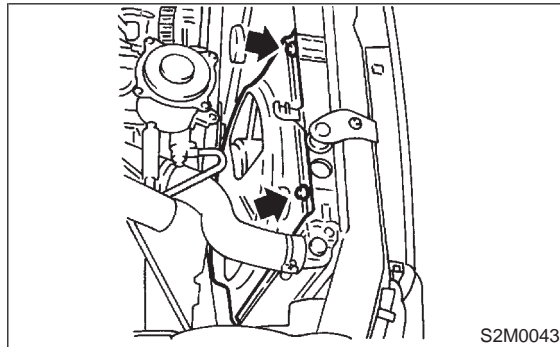

- 4) Pull condenser fan assembly.
- 5) Install the condenser fan assembly in the reverse order of removal.

## 16. Flexible Hose

### A: REMOVAL AND INSTALLATION

**CAUTION:**

With the following cautions, replace flexible hoses with new ones if they are damaged or swollen.

- The flexible hoses should be free from twists and tension after they have been connected.
- The flexible hoses must not be bent or twisted forcibly.

- 1) Disconnect battery negative terminal.
- 2) Discharge refrigerant using refrigerant recovery system. <Ref. to 4-7 [W600].>
- 3) Remove low-pressure hose (A):

**CAUTION:**

Plug the opening to prevent foreign matter from getting in.

- (1) Remove hose attaching bolts (C).
- (2) Remove the hose assembly from evaporator unit.
- (3) Disconnect the low-pressure hose (A) from the hose assembly (E).
- 4) Remove high-pressure hose (B):

**CAUTION:**

Plug the opening to prevent foreign matter from getting in.

- (1) Remove hose attaching bolt (D).
- (2) Remove high-pressure hose (B).

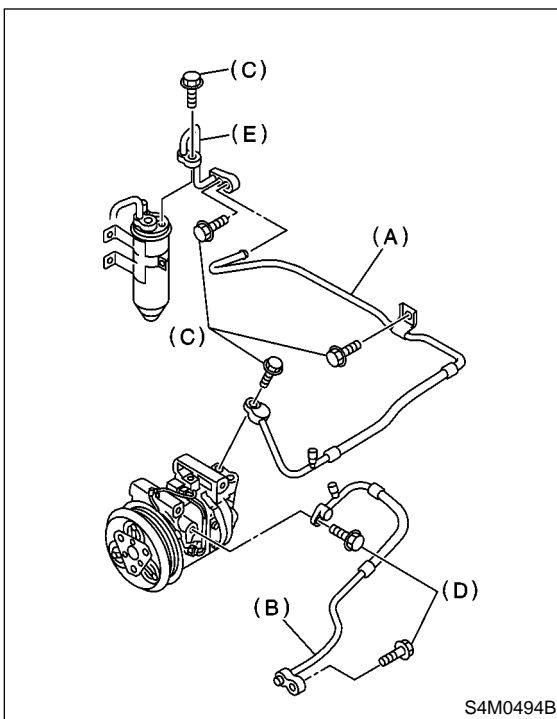

- 5) Install in the reverse order of removal.
- 6) Charge refrigerant. <Ref. to 4-7 [W700].>

## 17. Relay and Fuse

### A: LOCATION

Relays used with A/C system are located as shown in the figure.

- A/C relay
- Sub fan (condenser fan) relay
- Fuses (15 A and 20 A)

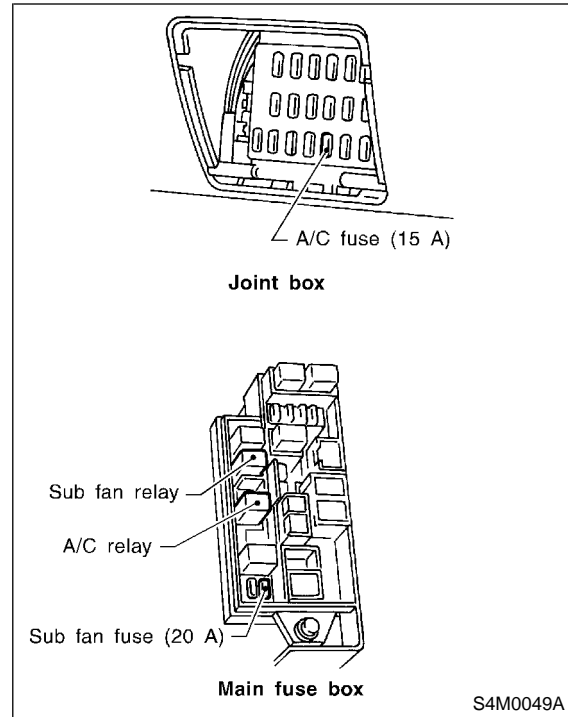



## 16. Flexible Hose

### A: REMOVAL AND INSTALLATION

**CAUTION:**

With the following cautions, replace flexible hoses with new ones if they are damaged or swollen.

- The flexible hoses should be free from twists and tension after they have been connected.
- The flexible hoses must not be bent or twisted forcibly.

- 1) Disconnect battery negative terminal.
- 2) Discharge refrigerant using refrigerant recovery system. <Ref. to 4-7 [W600].>
- 3) Remove low-pressure hose (A):

**CAUTION:**

Plug the opening to prevent foreign matter from getting in.

- (1) Remove hose attaching bolts (C).
- (2) Remove the hose assembly from evaporator unit.
- (3) Disconnect the low-pressure hose (A) from the hose assembly (E).
- 4) Remove high-pressure hose (B):

**CAUTION:**

Plug the opening to prevent foreign matter from getting in.

- (1) Remove hose attaching bolt (D).
- (2) Remove high-pressure hose (B).

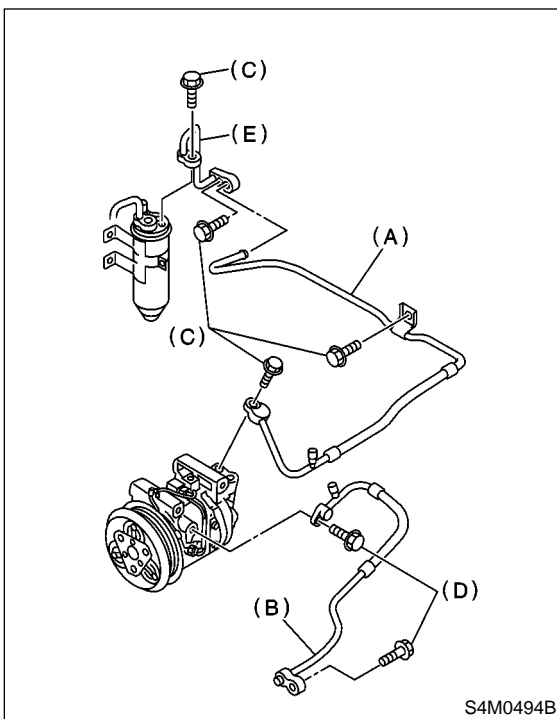

S4M0494B

- 5) Install in the reverse order of removal.
- 6) Charge refrigerant. <Ref. to 4-7 [W700].>

## 17. Relay and Fuse

### A: LOCATION

Relays used with A/C system are located as shown in the figure.

- A/C relay
- Sub fan (condenser fan) relay
- Fuses (15 A and 20 A)

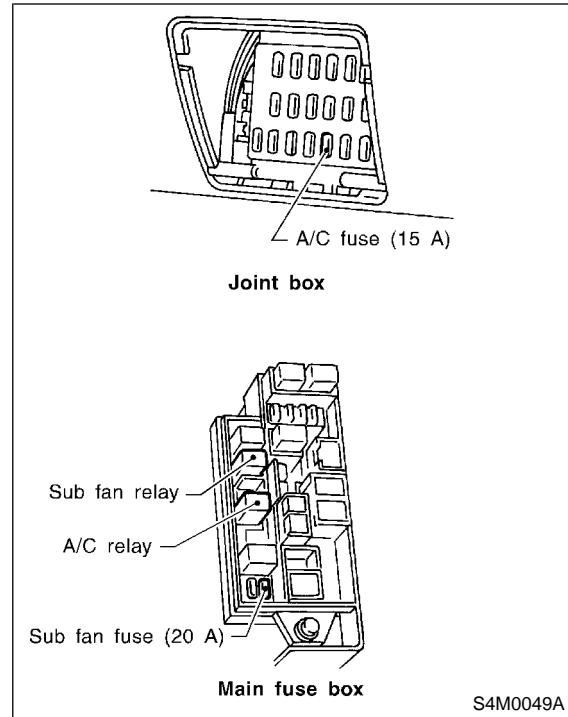

S4M0049A

**B: INSPECTION**

Check conduction with a circuit tester (ohm range) according to the following figure.

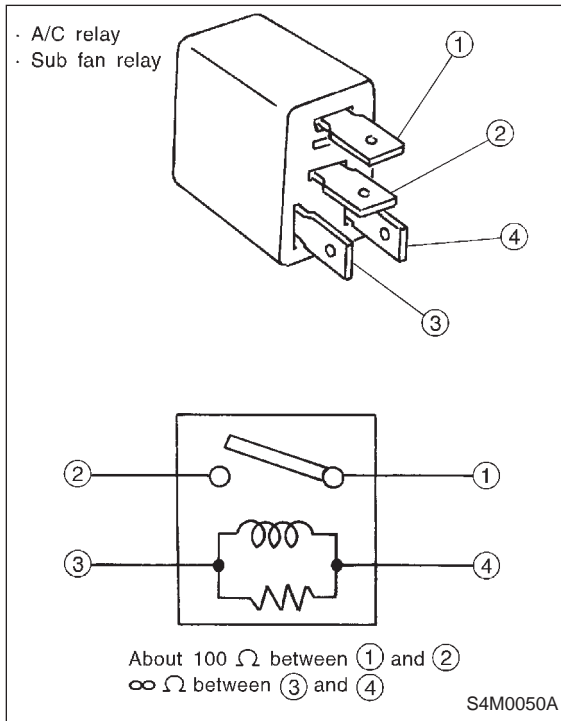

**18. Pressure Switch (Dual Switch)**

**A: INSPECTION**

**NOTE:**

Pressure switch is attached to receiver dryer. It has two built-in switches.

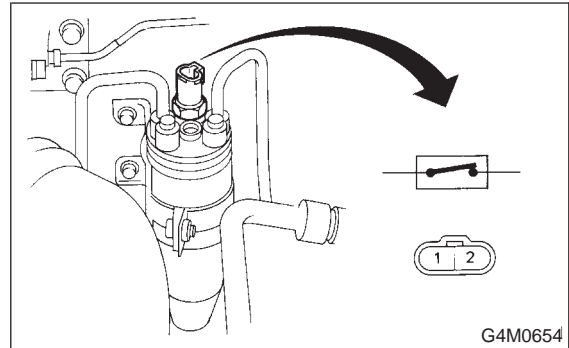

- 1) Remove cap from high-pressure line service valve, and connect gauge manifold to service valve.
- 2) Disconnect pressure switch harness connector, and check pressure switch for proper ON-OFF operation. Use a circuit tester.

	Terminal	Operation	High-pressure side line pressure
High and low pressure switch	1 — 2	Turns OFF.	Increasing to 2,940±200 kPa (29.98±2.04 kg/cm <sup>2</sup> , 426.3±29.0 psi)
			Decreasing to 177±25 kPa (1.80±0.25 kg/cm <sup>2</sup> , 25.6±3.6 psi)
		Turns ON.	Increasing to Less than 216 kPa (2.2 kg/cm <sup>2</sup> , 31 psi)
			Decreasing to 2,354±196 kPa (24±2 kg/cm <sup>2</sup> , 341±28 psi)

**B: INSPECTION**

Check conduction with a circuit tester (ohm range) according to the following figure.

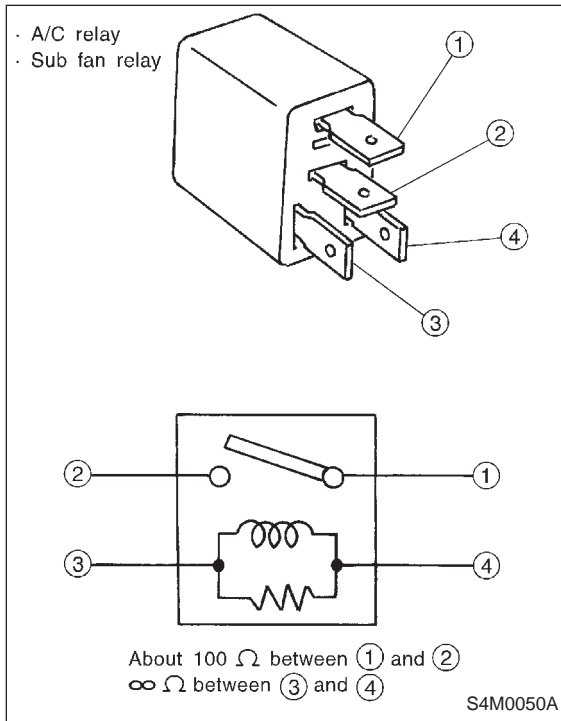

**18. Pressure Switch (Dual Switch)**

**A: INSPECTION**

**NOTE:**

Pressure switch is attached to receiver dryer. It has two built-in switches.

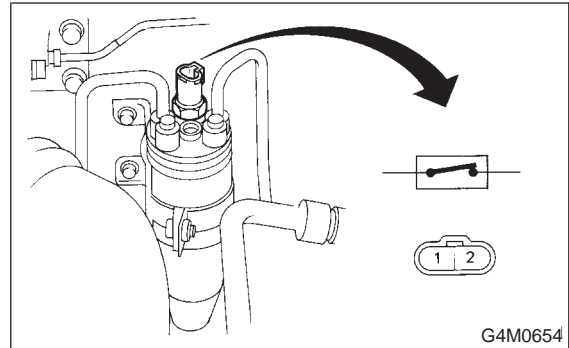

- 1) Remove cap from high-pressure line service valve, and connect gauge manifold to service valve.
- 2) Disconnect pressure switch harness connector, and check pressure switch for proper ON-OFF operation. Use a circuit tester.

	Terminal	Operation	High-pressure side line pressure
High and low pressure switch	1 — 2	Turns OFF.	Increasing to 2,940±200 kPa (29.98±2.04 kg/cm <sup>2</sup> , 426.3±29.0 psi)
			Decreasing to 177±25 kPa (1.80±0.25 kg/cm <sup>2</sup> , 25.6±3.6 psi)
		Turns ON.	Increasing to Less than 216 kPa (2.2 kg/cm <sup>2</sup> , 31 psi)
			Decreasing to 2,354±196 kPa (24±2 kg/cm <sup>2</sup> , 341±28 psi)

# 1. Air Conditioning System Diagnosis

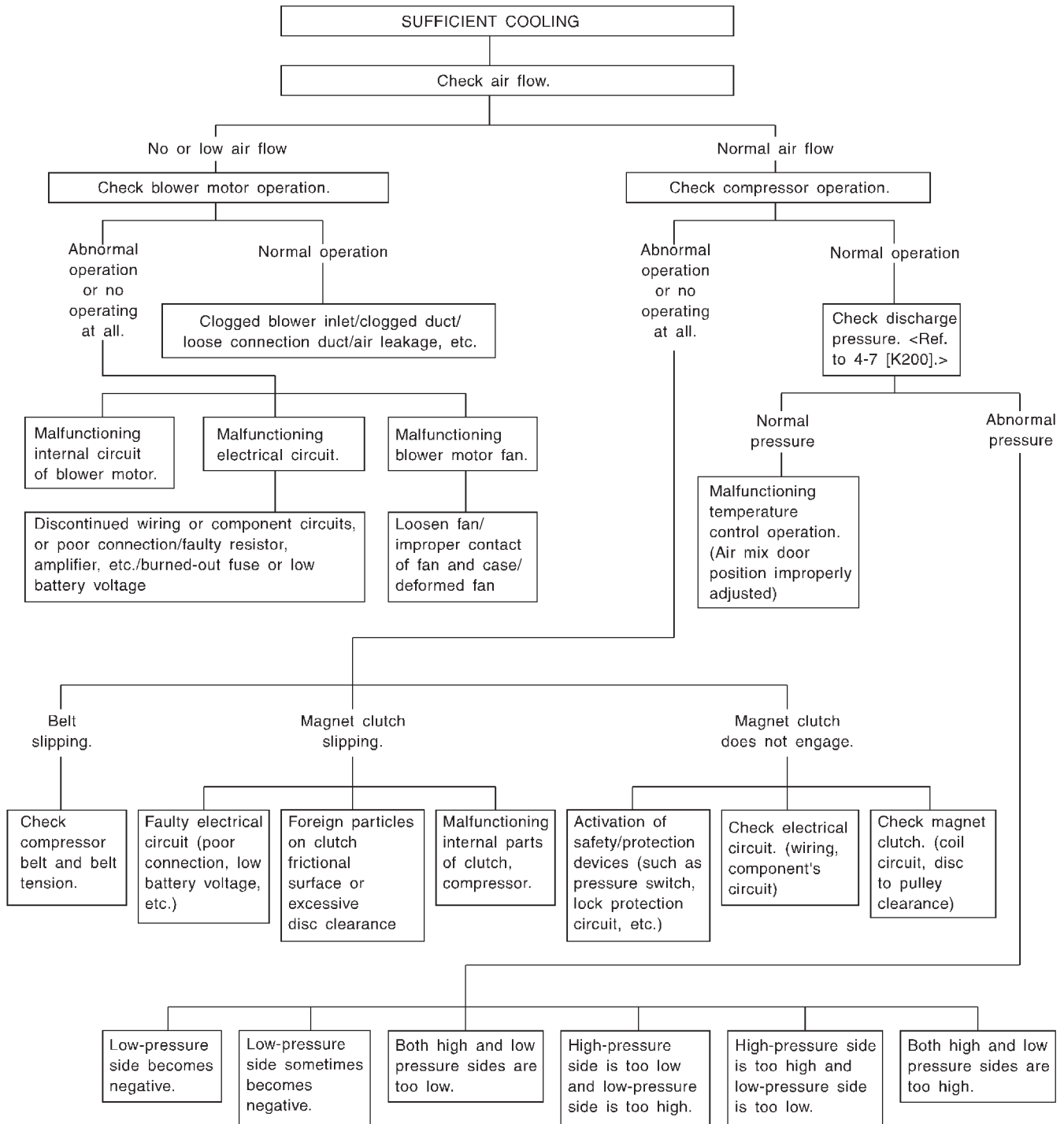

H4M1265A









## 2. Performance Test Diagnosis

In various conditions caused to other air conditioning system, the characteristics revealed on manifold gauge reading are shown in the following.

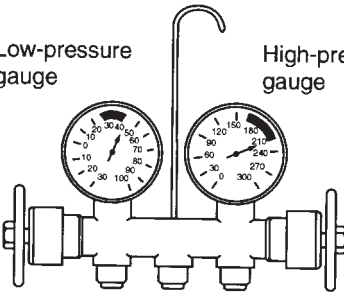
As to the method of a performance test, refer to the item of "Performance Test".

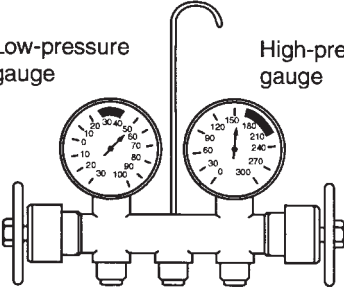
Each shaded area on the following tables indicates a reading of the normal system when the temperature of outside air is 32.5°C (91°F).

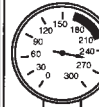
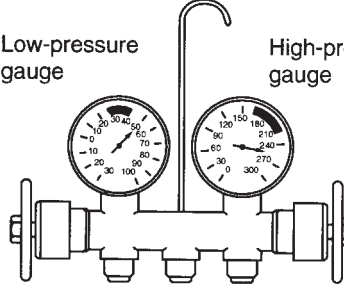
Condition	Probable cause	Corrective action
<p data-bbox="115 415 570 443">INSUFFICIENT REFRIGERANT CHARGE</p> <div data-bbox="185 474 594 764"> <p data-bbox="185 510 324 562">Low-pressure gauge</p> <p data-bbox="451 510 594 562">High-pressure gauge</p> </div> <p data-bbox="594 806 675 827">G4M0673</p>	<p data-bbox="699 415 906 443">Insufficient cooling.</p> <p data-bbox="979 415 1192 474">Refrigerant is small, or leaking a little.</p>	<p data-bbox="1230 415 1430 590">1. Leak test. 2. Repair leak. 3. Charge system. Evacuate, as necessary, and recharge system.</p>
<p data-bbox="115 835 435 863">ALMOST NO REFRIGERANT</p> <div data-bbox="185 894 594 1184"> <p data-bbox="185 930 324 982">Low-pressure gauge</p> <p data-bbox="451 930 594 982">High-pressure gauge</p> </div> <p data-bbox="594 1226 675 1247">G4M0674</p>	<p data-bbox="699 835 894 863">No cooling action.</p> <p data-bbox="979 835 1179 894">Serious refrigerant leak.</p>	<p data-bbox="1230 835 1458 1125">Stop compressor immediately. 1. Leak test. 2. Discharge system. 3. Repair leak(s). 4. Replace receiver drier if necessary. 5. Check oil level. 6. Evacuate and recharge system.</p>
<p data-bbox="115 1255 431 1283">FAULTY EXPANSION VALVE</p> <div data-bbox="185 1335 594 1625"> <p data-bbox="185 1371 324 1423">Low-pressure gauge</p> <p data-bbox="451 1371 594 1423">High-pressure gauge</p> </div> <p data-bbox="594 1667 675 1688">G4M0675</p>	<p data-bbox="699 1255 932 1341">Slight cooling. Sweating or frosted expansion valve inlet.</p> <p data-bbox="979 1255 1211 1545">Expansion valve restricts refrigerant flow. ● Expansion valve is clogged. ● Expansion valve is inoperative. ● Valve stuck closed. Thermal bulb has lost charge.</p>	<p data-bbox="1230 1255 1468 1661">● If valve inlet reveals sweat or frost: 1. Discharge system. 2. Remove valve and clean it. Replace it if necessary. 3. Evacuate system. 4. Charge system. ● If valve does not operate: 1. Discharge system. 2. Replace valve. 3. Evacuate and charge system.</p>

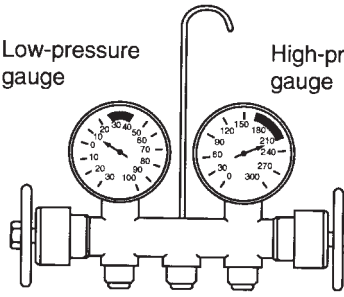
Condition		Probable cause	Corrective action
<div style="display: flex; justify-content: space-around;"> <div style="text-align: center;"> <p>Low-pressure gauge</p>  </div> <div style="text-align: center;"> <p>High-pressure gauge</p>  </div> </div>  <p style="text-align: right;">G4M0676</p>	<p>Insufficient cooling. Sweated suction line. No cooling. Sweating or frosted suction line.</p>	<p>Expansion valve allows too much refrigerant through evaporator. Faulty seal of O-ring in expansion valve.</p>	<p>Check valve for operation. If suction side does not show a pressure decrease, replace valve. 1. Discharge system. 2. Remove expansion valve and replace O-ring. 3. Evacuate and replace system.</p>
<div style="display: flex; justify-content: space-around;"> <div style="text-align: center;"> <p>Low-pressure gauge</p>  </div> <div style="text-align: center;"> <p>High-pressure gauge</p>  </div> </div>  <p style="text-align: right;">G4M0677</p>	<p>Insufficient cooling.</p>	<p>Air mixed with refrigerant in system.</p>	<p>1. Discharge system. 2. Replace receiver drier. 3. Evacuate and charge system.</p>
<p><b>AIR IN SYSTEM</b></p>	<div style="display: flex; justify-content: space-around;"> <div style="text-align: center;"> <p>Low-pressure gauge</p>  </div> <div style="text-align: center;"> <p>High-pressure gauge</p>  </div> </div>  <p style="text-align: right;">G4M0678</p>	<p>After operation for a while, pressure on suction side may show vacuum pressure reading. During this condition, discharge air will be warm. As warning of this, reading shows 39 kPa (0.4 kg/cm<sup>2</sup>, 6 psi) vibration.</p>	<p>Drier is saturated with moisture. Moisture has frozen at expansion valve. Refrigerant flow is restricted.</p>
<p><b>MOISTURE IN SYSTEM</b></p>	<div style="display: flex; justify-content: space-around;"> <div style="text-align: center;"> <p>Low-pressure gauge</p>  </div> <div style="text-align: center;"> <p>High-pressure gauge</p>  </div> </div>  <p style="text-align: right;">G4M0679</p>	<p>1. Discharge system. 2. Replace receiver drier (twice if necessary). 3. Evacuate system completely. (Repeat 30 minute evacuating three times.) 4. Recharge system.</p>	

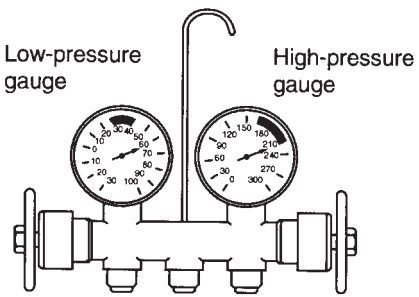
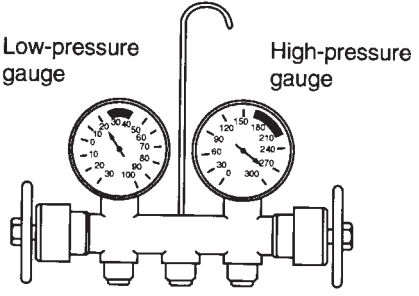
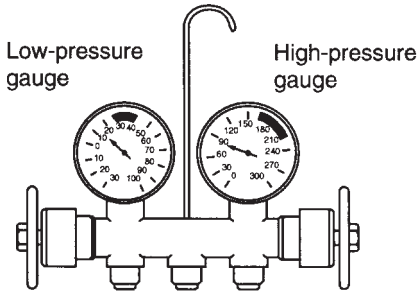
Condition	Probable cause	Corrective action
<p><b>FAULTY CONDENSER</b></p>  <p>Low-pressure gauge</p> <p>High-pressure gauge</p> <p>G4M0680</p>	<p>No cooling action. Engine may overheat. Suction line is very hot.</p>	<p>Condenser is often found not functioning well.</p> <ul style="list-style-type: none"> <li>● Check condenser cooling fan.</li> <li>● Check condenser for dirt accumulation.</li> <li>● Check engine cooling system for overheat.</li> <li>● Check for refrigerant overcharge.</li> <li>● If pressure remains high in spite of all above actions taken, remove and inspect the condenser for possible oil clogging.</li> </ul>
<p><b>HIGH-PRESSURE LINE BLOCKED</b></p>  <p>Low-pressure gauge</p> <p>High-pressure gauge</p> <p>G4M0681</p>	<p>Insufficient cooling. Frosted high-pressure liquid line.</p>	<p>Drier clogged, or restriction in high-pressure line.</p> <ol style="list-style-type: none"> <li>1. Discharge system.</li> <li>2. Remove receiver drier or strainer and replace it.</li> <li>3. Evacuate and charge system.</li> </ol>
<p><b>FAULTY COMPRESSOR</b></p>  <p>Low-pressure gauge</p> <p>High-pressure gauge</p> <p>G4M0682</p>	<p>Insufficient cooling.</p>	<p>Internal problem in compressor, or damaged gasket and valve.</p> <ol style="list-style-type: none"> <li>1. Discharge system.</li> <li>2. Remove and check compressor.</li> <li>3. Repair or replace compressor.</li> <li>4. Check oil level.</li> <li>5. Replace receiver drier.</li> <li>6. Evacuate and charge system.</li> </ol>

### 3. Blower Motor Diagnosis

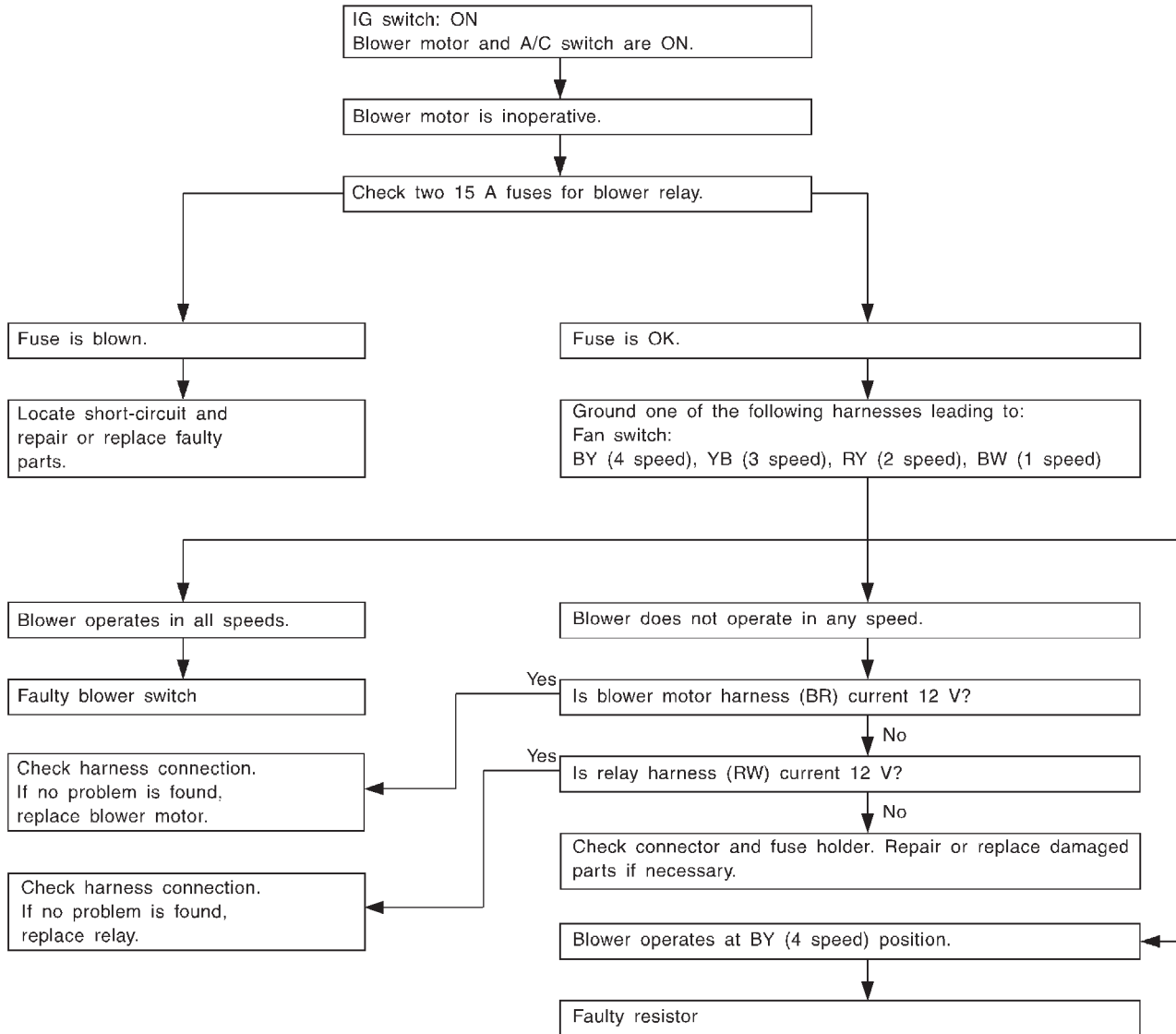

S4M0294A



# 4. Compressor Diagnosis

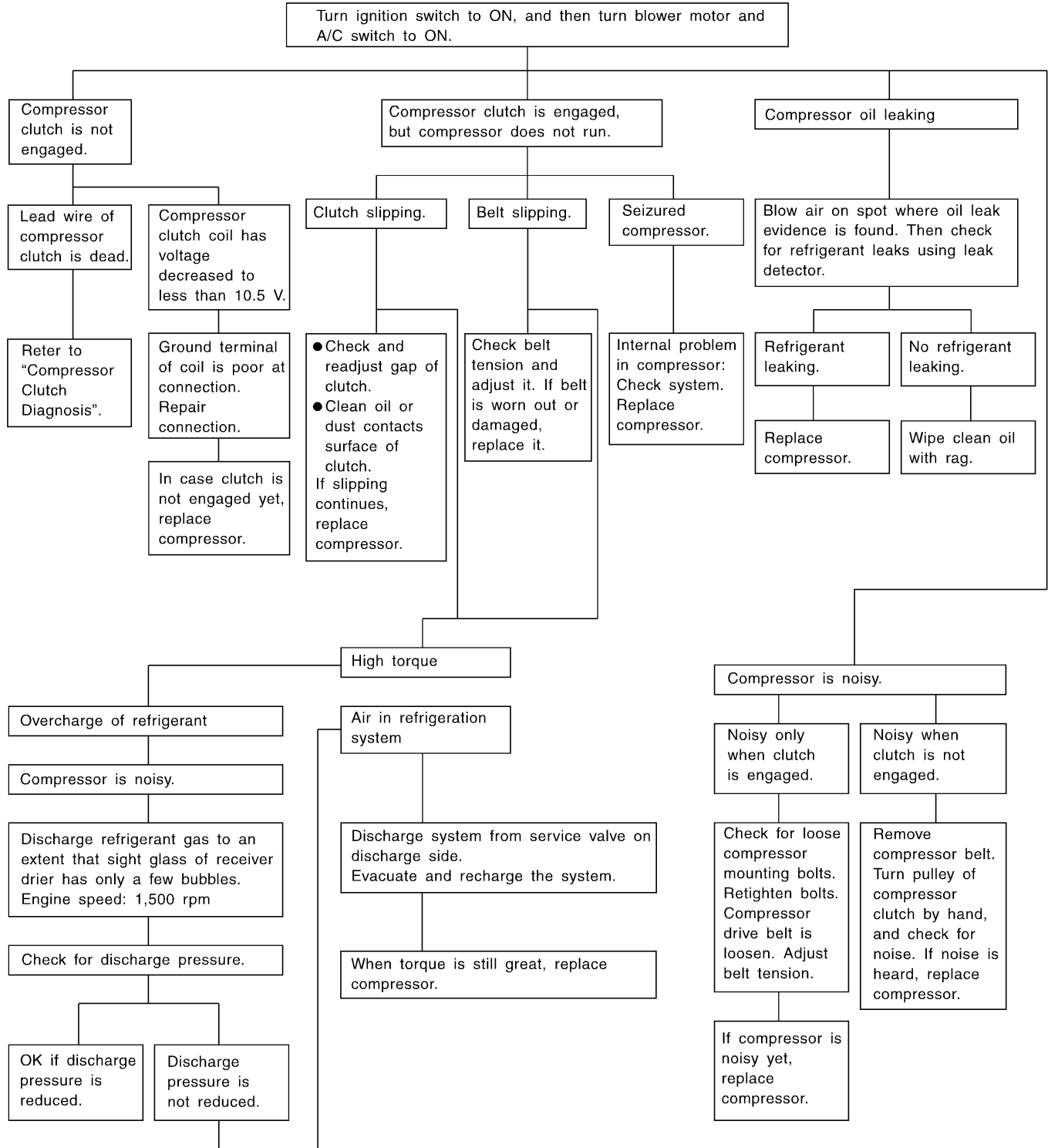

# 5. Compressor Clutch Diagnosis

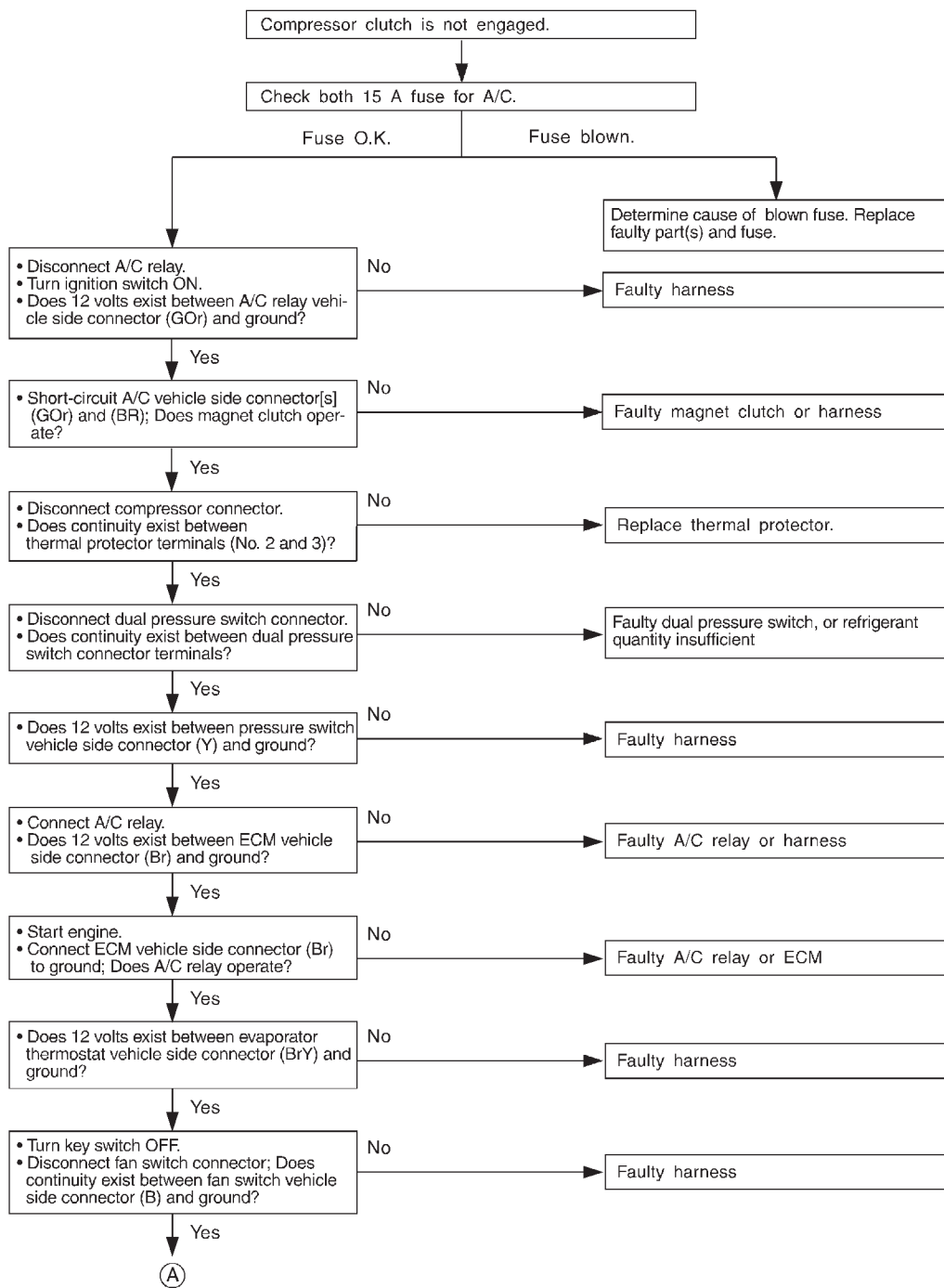

S4M0295A

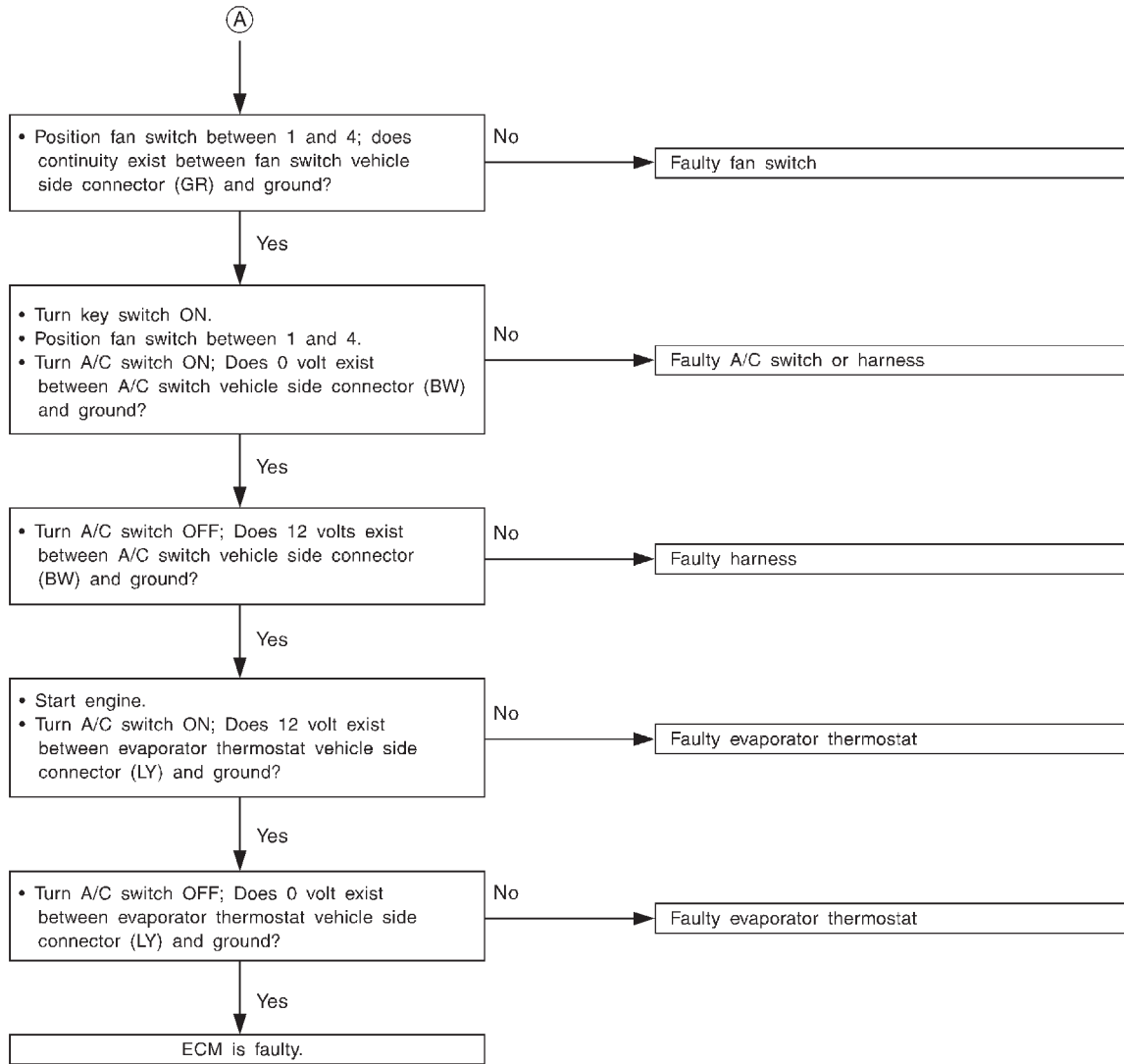

S4M0296A