

1. General Description

A: WIRING DIAGRAM

The wiring diagram of each system is illustrated so that you can understand the path through which the electric current flows from the battery.

Sketches and codes are used in the diagrams. They should read as follows:

- Each connector and its terminal position are indicated by a sketch of the connector in a disconnected state which is viewed from the front.

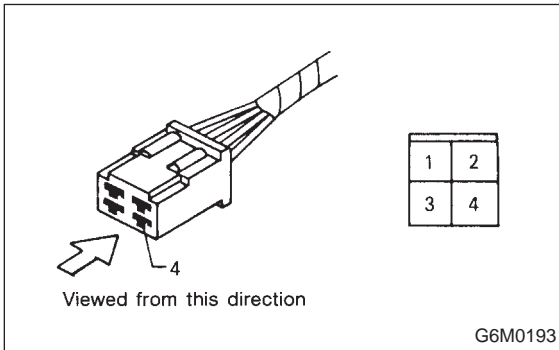

- The number of poles or pins, presence of a lock, and pin number of each terminal are indicated in the sketch of each connector. In the sketch, the highest pole number refers to the number of poles which the connector has. For example, the sketch of the connector shown in figure indicates the connector has 9 poles.

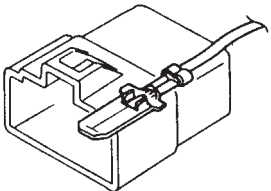
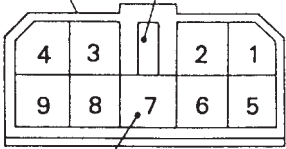
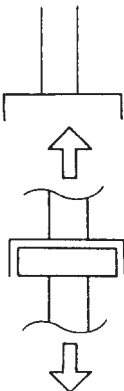
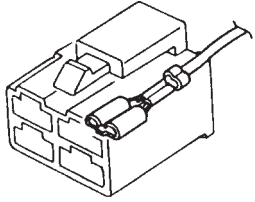
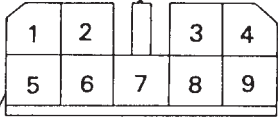
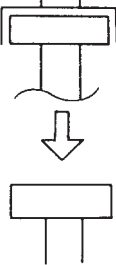
Connector used in vehicle	Connector shown in wiring diagram		
	Sketch	Symbol	Number of poles
 G6M0194	Double frames Indicates a lock is included.  Indicates the number of poles. G6M0196		Numbered in order from upper right to lower left.
 G6M0195	Indicates a lock is included.  Single frame G6M0197	 G6M0198	Numbered in order from upper left to lower right.

- When one set of connectors is viewed from the front side, the pole numbers of one connector are symmetrical to those of the other. When these two connectors are connected as a unit, the poles which have the same number are joined.

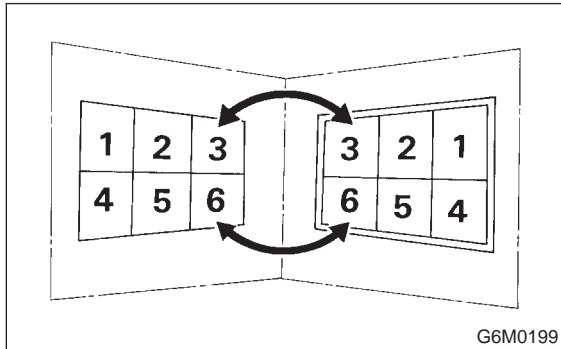

- Electrical wiring harness:**
The connectors are numbered along with the number of poles, external colors, and mating connections in the accompanying list.
- The sketch of each connector in the wiring diagram usually shows the (A) side of the connector. The relationship between the wire color, terminal number and connector is described in figure.

NOTE:

A wire which runs in one direction from a connector terminal sometimes may have a different color from that which runs in the other direction from that terminal.

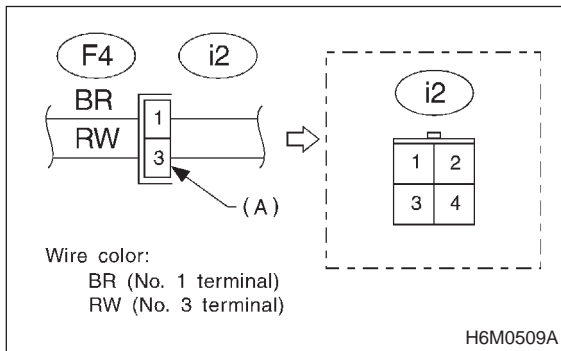

- In wiring diagram, connectors which have no terminal number refer to one-pole types. Sketches of these connectors are omitted intentionally.

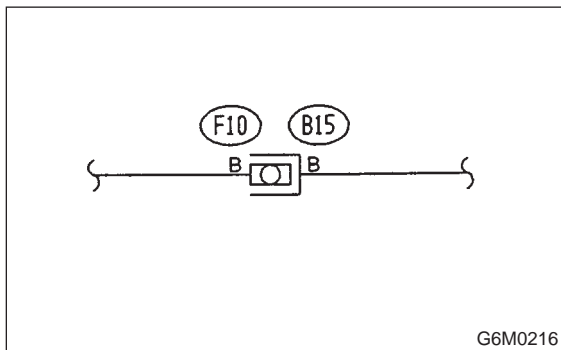

- The following color codes are used to indicate the colors of the wires used.

Color code	Color
L	Blue
B	Black
Y	Yellow
G	Green
R	Red
W	White
Br	Brown
Lg	Light green
Gr	Gray
P	Pink
Or	Orange
Lb	Light Blue
V	Violet
SA	Sealed (Inner)
SB	Sealed (Outer)

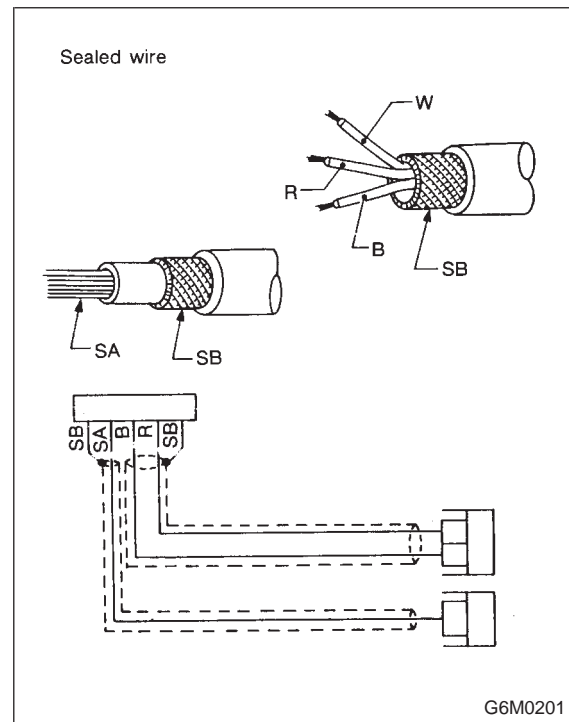

1. General Description

- The wire color code, which consists of two letters (or three letters including Br or Lg), indicates the standard color (base color of the wire covering) by its first letter and the stripe marking by its second letter.

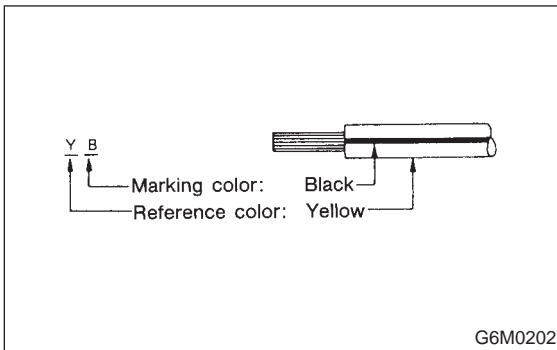

- The table lists the nominal sectional areas and allowable currents of the wires.

CAUTION:

● When replacing or repairing a wire, be sure to use the same size and type of the wire which was originally used.

NOTE:

- The allowable current in the table indicates the tolerable amperage of each wire at an ambient temperature of 40°C (104°F).
- The allowable current changes with ambient temperature. Also, it changes if a bundle of more than two wires is used.

Nominal sectional area mm ²	No. of strands/ strand diameter	Outside diameter of finished wiring mm	Allowable current Amps/40°C
0.3	7/0.26	1.8	7
0.5	7/0.32	2.2 (or 2.0)	12
0.75	30/0.18	2.6 (or 2.4)	16
0.85	11/0.32	2.4 (or 2.2)	16
1.25	16/0.32	2.7 (or 2.5)	21
2	26/0.32	3.1 (or 2.9)	28
3	41/0.32	3.8 (or 3.6)	38
5	65/0.32	4.6 (or 4.4)	51
8	50/0.45	5.5	67

- Each unit is directly grounded to the body or indirectly grounds through a harness ground terminal. Different symbols are used in the wiring diagram to identify the two grounding systems.

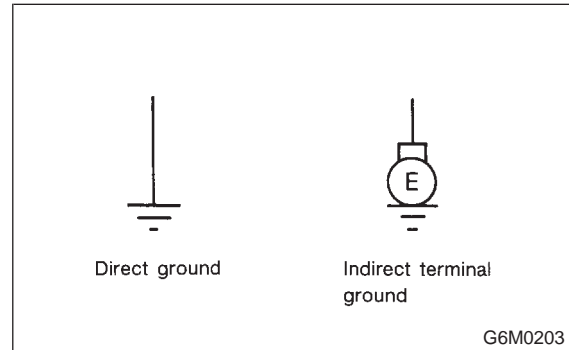

- The ground points shown in the wiring diagram refer to the following:

NOTE:

All wiring harnesses are provided with a ground point which should be securely connected.

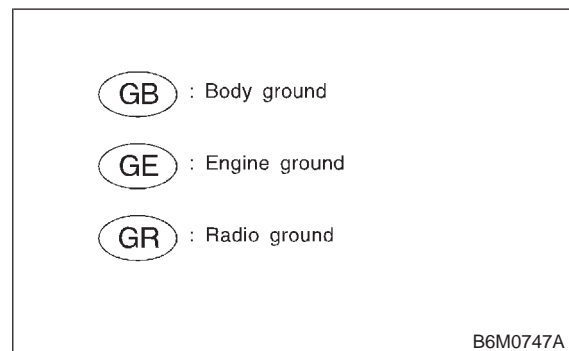

- Relays are classified as normally-open or normally-closed. The normally-closed relay has one or more contacts.
- The wiring diagram shows the relay mode when the energizing circuit is OFF.

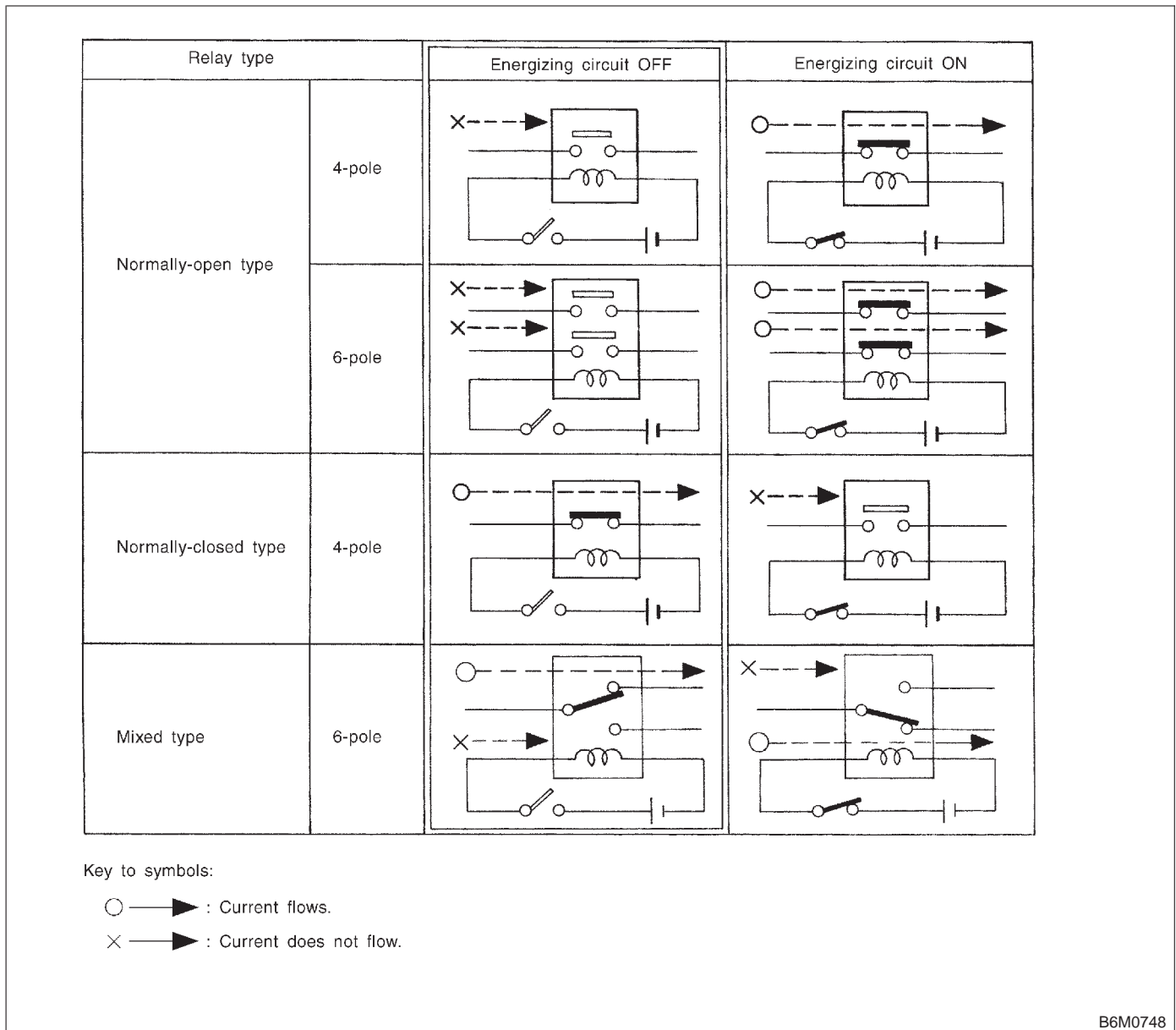

2. Basic Diagnostics Procedure

- Each connector number shown in the wiring diagram corresponds to that in the wiring harness. The location of each connector in the actual vehicle is determined by reading the first character of the connector (for example, a "F" for F8, "i" for i16, etc.) and the type of wiring harness. The first character of each connector number refers to the area or system of the vehicle.

Symbol	Wiring harness and cord
F	Front wiring harness
B	Bulkhead wiring harness
E	Engine wiring harness, Oxygen sensor cord
T	Transmission cord
D	Door cord LH & RH, Rear door cord LH & RH
i	Instrument panel wiring harness
R	Rear wiring harness, Rear defogger cord (Ground) Fuel tank cord, Roof cord, Rear gate cord, Rear gate lock adapter cord

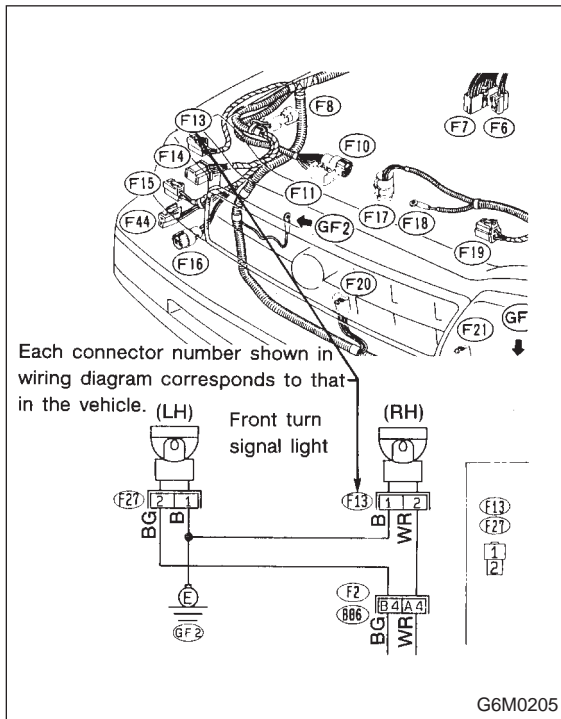

2. Basic Diagnostics Procedure

A: BASIC PROCEDURE

1. GENERAL

The most important purpose of diagnostics is to determine which part is malfunctioning quickly, to save time and labor.

2. IDENTIFICATION OF TROUBLE SYMPTOM

Determine what the problem is based on the symptom.

3. PROBABLE CAUSE OF TROUBLE

Look at the wiring diagram and check the system's circuit. Then check the switch, relay, fuse, ground, etc.

4. LOCATION AND REPAIR OF TROUBLE

- 1) Using the diagnostics narrow down the causes.
- 2) If necessary, use a voltmeter, ohmmeter, etc.
- 3) Before replacing certain component parts (switch, relay, etc.), check the power supply, ground, for open wiring harness, poor connectors, etc. If no problems are encountered, check the component parts.

5. CONFIRMATION OF SYSTEM OPERATION

After repairing, ensure that the system operates properly.

B: INSPECTION

1. VOLTAGE MEASUREMENT

- 1) Using a voltmeter, connect the negative lead to a good ground point or negative battery terminal and the positive lead to the connector or component terminal.
 - 2) Contact the positive probe of the voltmeter on connector (A).
- The voltmeter will indicate a voltage.
- 3) Shift the positive probe to connector (B). The voltmeter will indicate no voltage.

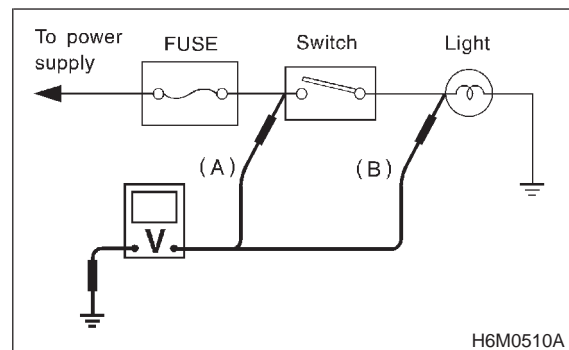

2. Basic Diagnostics Procedure

- Each connector number shown in the wiring diagram corresponds to that in the wiring harness. The location of each connector in the actual vehicle is determined by reading the first character of the connector (for example, a "F" for F8, "i" for i16, etc.) and the type of wiring harness. The first character of each connector number refers to the area or system of the vehicle.

Symbol	Wiring harness and cord
F	Front wiring harness
B	Bulkhead wiring harness
E	Engine wiring harness, Oxygen sensor cord
T	Transmission cord
D	Door cord LH & RH, Rear door cord LH & RH
i	Instrument panel wiring harness
R	Rear wiring harness, Rear defogger cord (Ground) Fuel tank cord, Roof cord, Rear gate cord, Rear gate lock adapter cord

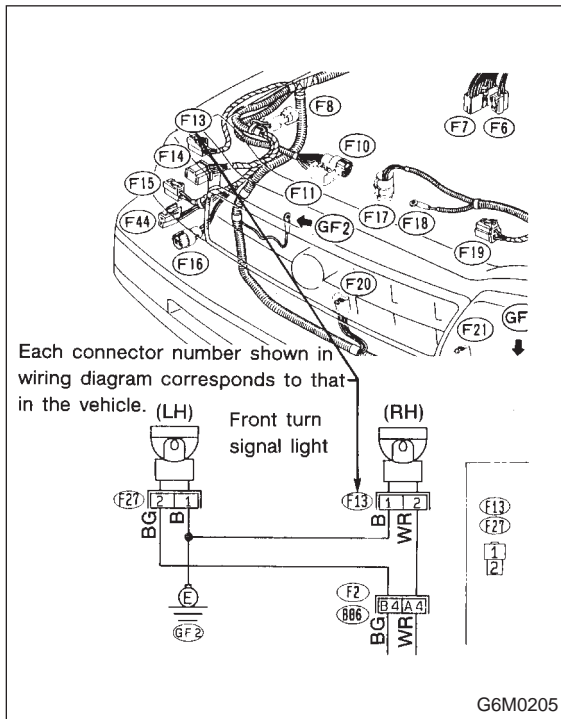

2. Basic Diagnostics Procedure

A: BASIC PROCEDURE

1. GENERAL

The most important purpose of diagnostics is to determine which part is malfunctioning quickly, to save time and labor.

2. IDENTIFICATION OF TROUBLE SYMPTOM

Determine what the problem is based on the symptom.

3. PROBABLE CAUSE OF TROUBLE

Look at the wiring diagram and check the system's circuit. Then check the switch, relay, fuse, ground, etc.

4. LOCATION AND REPAIR OF TROUBLE

- 1) Using the diagnostics narrow down the causes.
- 2) If necessary, use a voltmeter, ohmmeter, etc.
- 3) Before replacing certain component parts (switch, relay, etc.), check the power supply, ground, for open wiring harness, poor connectors, etc. If no problems are encountered, check the component parts.

5. CONFIRMATION OF SYSTEM OPERATION

After repairing, ensure that the system operates properly.

B: INSPECTION

1. VOLTAGE MEASUREMENT

- 1) Using a voltmeter, connect the negative lead to a good ground point or negative battery terminal and the positive lead to the connector or component terminal.
 - 2) Contact the positive probe of the voltmeter on connector (A).
 - 3) Shift the positive probe to connector (B). The voltmeter will indicate a voltage.
- The voltmeter will indicate a voltage.
- Shift the positive probe to connector (B). The voltmeter will indicate no voltage.

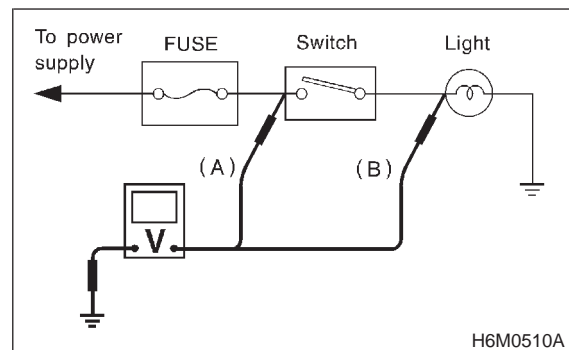

- 4) With test set-up held as it is, turn switch ON. The voltmeter will indicate a voltage and, at the same time, the light will come on.
- 5) The circuit is in good order. If a problem such as a lamp failing to light occurs, use the procedures outlined above to track down the malfunction.

2. CIRCUIT CONTINUITY CHECKS

- 1) Disconnect the battery terminal or connector so there is no voltage between the check points. Contact the two leads of an ohmmeter to each of the check points. If the circuit has diodes, reverse the two leads and check again.
- 2) Use an ohmmeter to check for diode continuity. When contacting the negative lead to the diode positive side and the positive lead to the negative side, there should be continuity. When contacting the two leads in reverse, there should be no continuity.

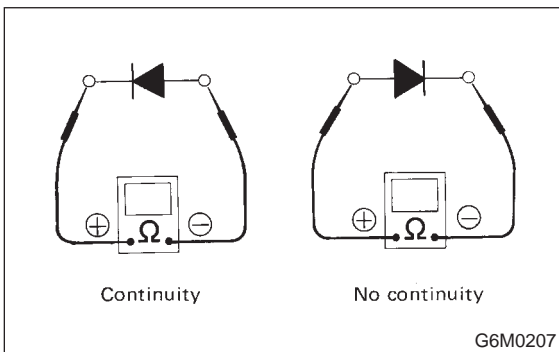

3) Symbol “○—○” indicates that continuity exists between two points or terminals. For example, when a switch position is “3”, continuity exists among terminals 1, 3 and 6, as shown in table below.

Terminal	1	2	3	4	5	6
Switch Position						
OFF						
1	○				○	○
2	○			○		○
3	○		○			○
4	○	○				○

3. HOW TO DETERMINE AN OPEN CIRCUIT

- 1) Voltmeter Method: An open circuit is determined by measuring the voltage between respective connectors and ground using a voltmeter, starting with the connector closest to the power supply. The power supply must be turned ON so that current flows in the circuit. If voltage is not present between a particular connector and ground, the circuit between that connector and the previous connector is open.

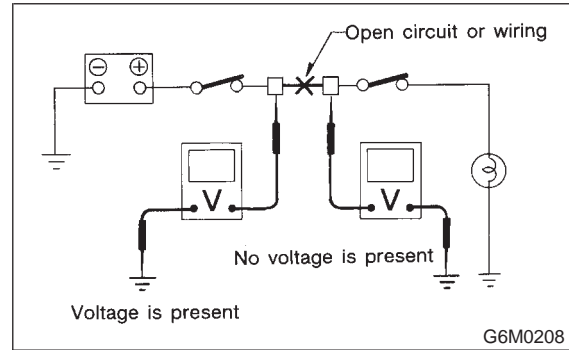

- 2) Ohmmeter method: Disconnect all connectors affected, and check continuity in the wiring between adjacent connectors. When the ohmmeter indicates “infinite”, the wiring is open.

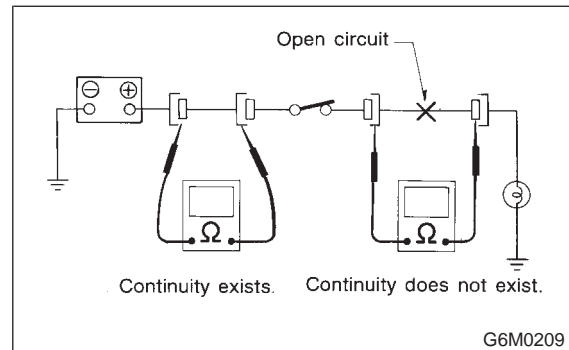

4. HOW TO DETERMINE A SHORTCIRCUIT

1) Test lamp method:

Connect a test lamp (rated at approximately 3 watts) in place of the blown fuse and allow current to flow through the circuit. Disconnect one connector at a time from the circuit, starting with the one located farthest from the power supply. If the test lamp goes out when a connector is disconnected, the wiring between that connection and the next connector (farther from the power supply) is shorted.

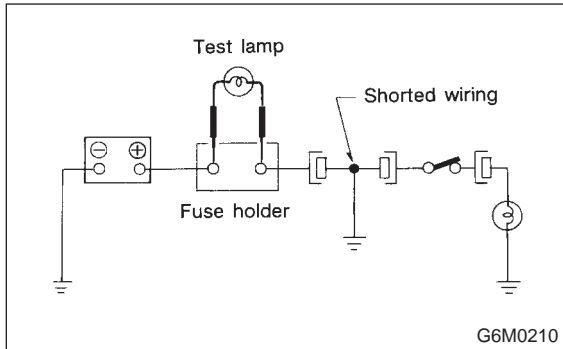

2) Ohmmeter method:

Disconnect all affected connectors, and check continuity between each connector and ground. When ohmmeter indicates continuity between a particular connector and ground, that connector is shorted.

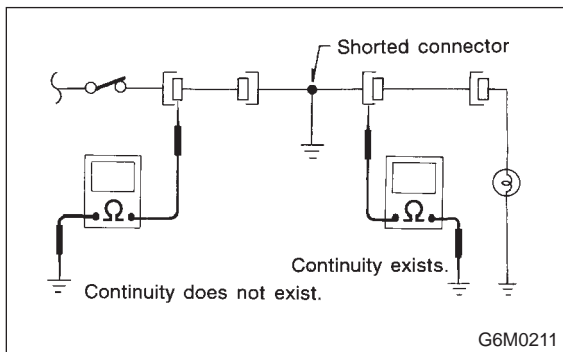

3. Working Precautions

A: PRECAUTIONS WHEN WORKING WITH THE PARTS MOUNTED ON THE VEHICLE

- 1) When working under a vehicle which is jacked-up, always be sure to use safety stands.
- 2) The parking brake must always be applied during working. Also, in automatic transmission vehicles, keep the select lever set to the P (Parking) range.
- 3) Be sure the workshop is properly ventilated when running the engine. Further, be careful not to touch the belt or fan while the engine is operating.
- 4) Be careful not to touch hot metal parts, especially the radiator and exhaust system immediately after the engine has been shut off.

B: PRECAUTIONS IN TROUBLE DIAGNOSIS AND REPAIR OF ELECTRIC PARTS

- 1) The battery cable must be disconnected from the battery's (-) terminal, and the ignition switch must be set to the OFF position, unless otherwise required by the diagnostics.
- 2) Securely fasten the wiring harness with clamps and slips so that the harness does not interfere with the body end parts or edges and bolts or screws.
- 3) When installing parts, be careful not to catch them on the wiring harness.
- 4) When disconnecting a connector, do not pull the wires, but pull while holding the connector body.

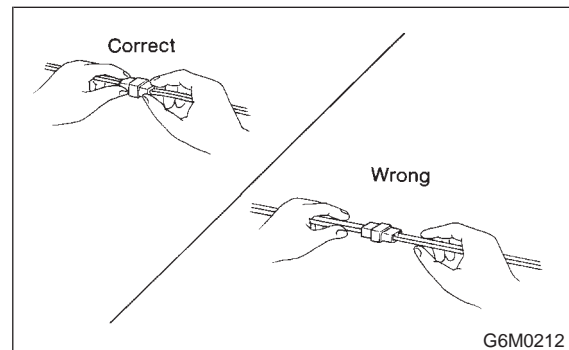

4. HOW TO DETERMINE A SHORTCIRCUIT

1) Test lamp method:

Connect a test lamp (rated at approximately 3 watts) in place of the blown fuse and allow current to flow through the circuit. Disconnect one connector at a time from the circuit, starting with the one located farthest from the power supply. If the test lamp goes out when a connector is disconnected, the wiring between that connection and the next connector (farther from the power supply) is shorted.

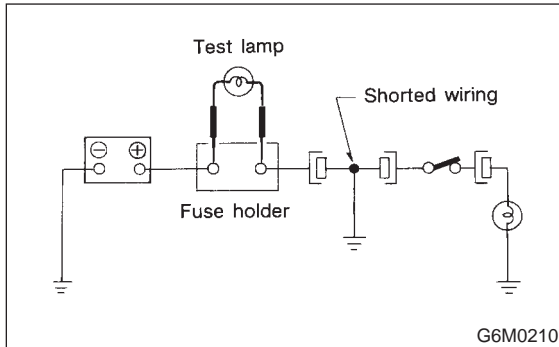

2) Ohmmeter method:

Disconnect all affected connectors, and check continuity between each connector and ground. When ohmmeter indicates continuity between a particular connector and ground, that connector is shorted.

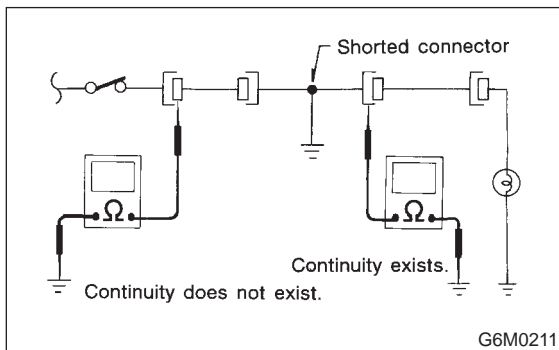

3. Working Precautions

A: PRECAUTIONS WHEN WORKING WITH THE PARTS MOUNTED ON THE VEHICLE

- 1) When working under a vehicle which is jacked-up, always be sure to use safety stands.
- 2) The parking brake must always be applied during working. Also, in automatic transmission vehicles, keep the select lever set to the P (Parking) range.
- 3) Be sure the workshop is properly ventilated when running the engine. Further, be careful not to touch the belt or fan while the engine is operating.
- 4) Be careful not to touch hot metal parts, especially the radiator and exhaust system immediately after the engine has been shut off.

B: PRECAUTIONS IN TROUBLE DIAGNOSIS AND REPAIR OF ELECTRIC PARTS

- 1) The battery cable must be disconnected from the battery's (-) terminal, and the ignition switch must be set to the OFF position, unless otherwise required by the diagnostics.
- 2) Securely fasten the wiring harness with clamps and slips so that the harness does not interfere with the body end parts or edges and bolts or screws.
- 3) When installing parts, be careful not to catch them on the wiring harness.
- 4) When disconnecting a connector, do not pull the wires, but pull while holding the connector body.

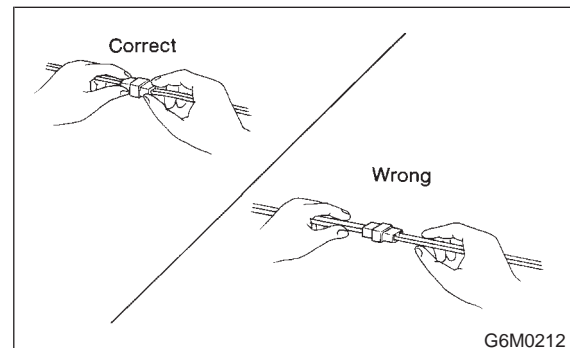

5) Some connectors are provided with a lock. One type of such a connector is disconnected by pushing the lock, and the other, by moving the lock up. In either type the lock shape must be identified before attempting to disconnect the connector. To connect, insert the connector until it snaps and confirm that it is tightly connected.

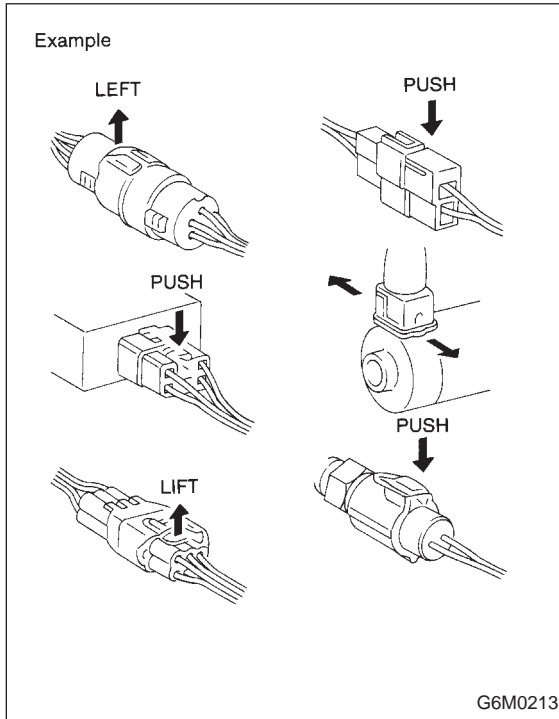

6) When checking continuity between connector terminals, or measuring voltage across the terminal and ground, always contact tester probe(s) on terminals from the wiring connection side. If the probe is too thick to gain access to the terminal, use "mini" test leads.

To check water-proof connectors (which are not accessible from the wiring side), contact test probes on the terminal side being careful not to bend or damage the terminals.

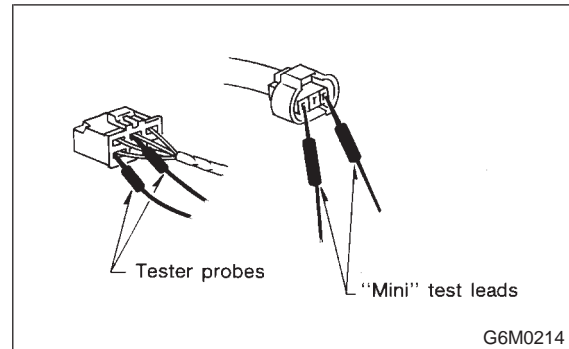

7) Sensors, relays, electrical unit, etc., are sensitive to strong impacts. Handle them with care so that they are not dropped or mishandled.

4. How to Use Wiring Diagram

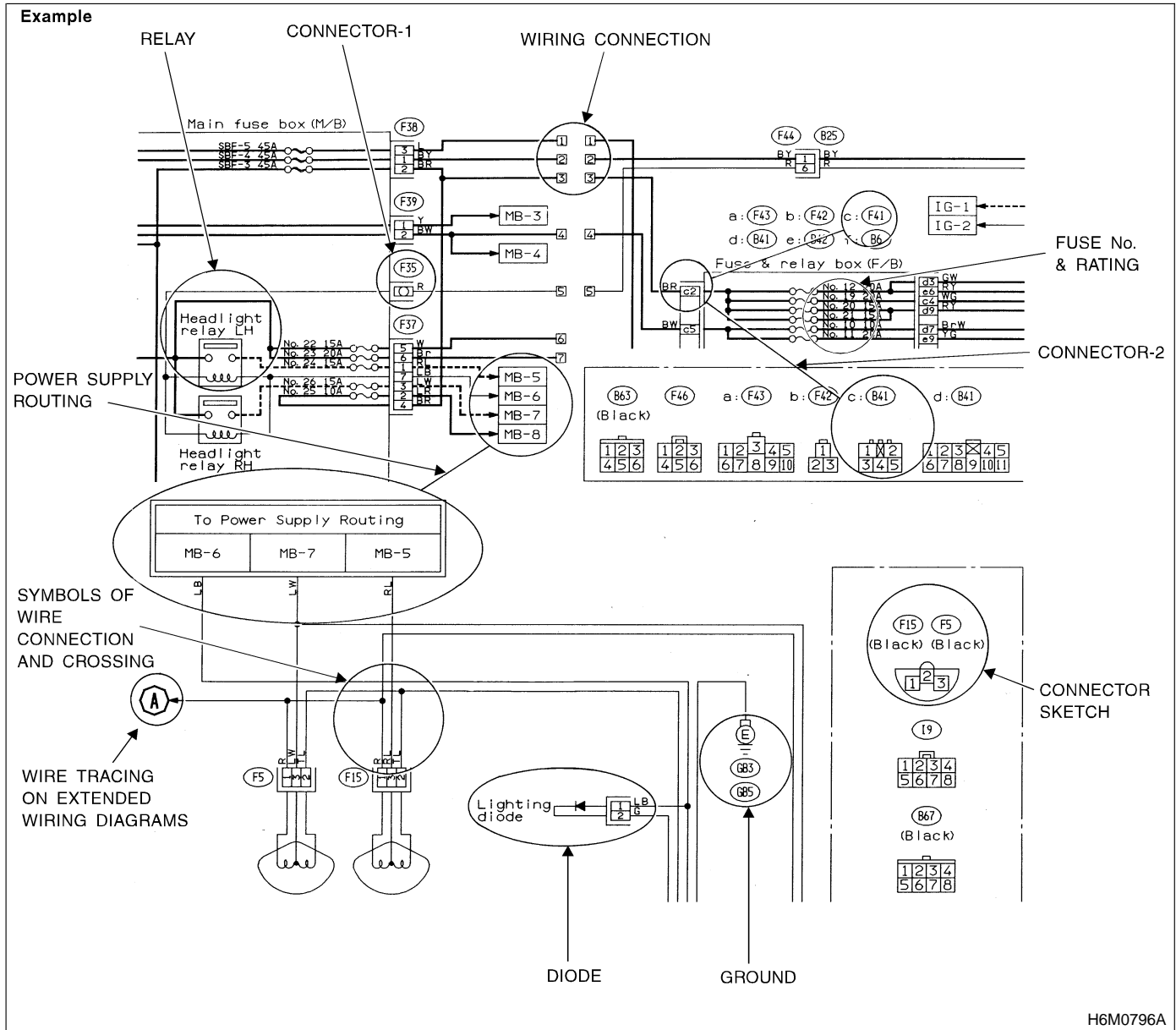

A: RELAY

A symbol used to indicate a relay.

B: CONNECTOR-1

The sketch of the connector indicates the one-pole types.

C: WIRING CONNECTION

Some wiring diagrams are indicated in foldouts for convenience. Wiring destinations are indicated where necessary by corresponding symbols (as when two pages are needed for clear indication).

D: FUSE No. & RATING

The "FUSE No. & RATING" corresponds with that used in the fuse box (main fuse box, fuse and joint box).

E: CONNECTOR-2

- Each connector is indicated by a symbol.
- Each terminal number is indicated in the corresponding wiring diagram in an abbreviated form.
- For example, terminal number "C2" refers to No. 2 terminal of connector (C: F41) shown in the connector sketch.

F: CONNECTOR SKETCH

- Each connector sketch clearly identifies the shape and color of a connector as well as terminal locations. Non-colored connectors are indicated in natural color.
- When more than two types of connector number are indicated in a connector sketch, it means that the same type connectors are used.

G: GROUND

Each grounding point can be located easily by referring to the corresponding wiring harness.

H: DIODE

A symbol is used to indicate a diode.

I: WIRE TRACING ON EXTENDED WIRING DIAGRAMS

For a wiring diagram extending over at least two pages, a symbol (consisting of the same characters with arrows), facilitates wire tracing from one page to the next.

A ↔ A, B ↔ B

J: SYMBOLS OF WIRE CONNECTION AND CROSSING

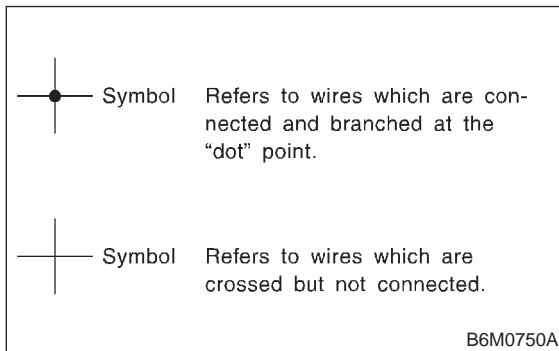

K: POWER SUPPLY ROUTING

A symbol is used to indicate the power supply in each wiring diagram.

“MB-5”, “MB-6”, etc., which are used as power-supply symbols throughout the text, correspond with those shown in the POWER SUPPLY ROUTING in the wiring diagram.

Accordingly, using the POWER SUPPLY ROUTING and wiring diagrams permits service personnel to understand the entire electrical arrangement of a system.

L: SYMBOLS AND ABBREVIATIONS

A number of symbols and abbreviations are used in each wiring diagram to easily identify parts or circuits.

M: ABBREVIATION LIST

Abbr.	Full name
ABS	Antilock Brake System
ACC	Accessory
A/C	Air Conditioning
AD	Auto Down
AT	Automatic Transmission
AU	Auto Up
+B	Battery
DN	Down
E	Ground
F/B	Fuse & Joint Box
FL1.5	Fusible link 1.5 mm ²
IG	Ignition
Illumi.	Illumination
LH	Left Hand
Lo	Low
M	Motor
M/B	Main Fuse Box
MG	Magnet
Mi	Middle
OP	Optional Parts
PASS	Passing
RH	Right Hand
SBF	Slow Blow Fuse
ST	Starter
SW	Switch
UP	Up
WASH	Washer

5. Wiring Diagram

A: POWER SUPPLY ROUTING

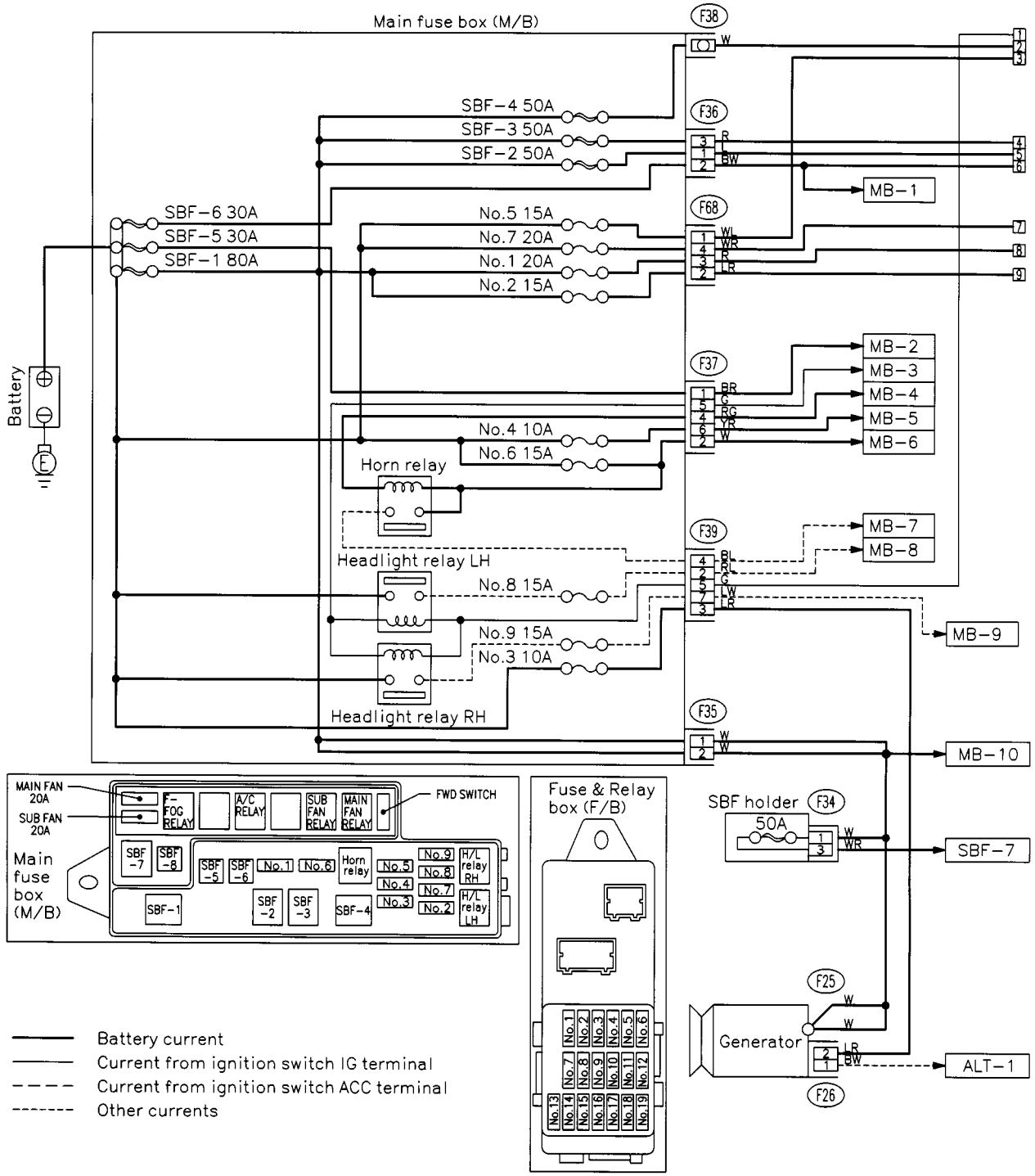

- Battery current
- Current from ignition switch IG terminal
- - - Current from ignition switch ACC terminal
- - - - Other currents

(F26) (Green) (F35) (F36) (F68) (Black) (F37) (Black) (F34) (F39) (Black)



SU01-04A

SU01-04A

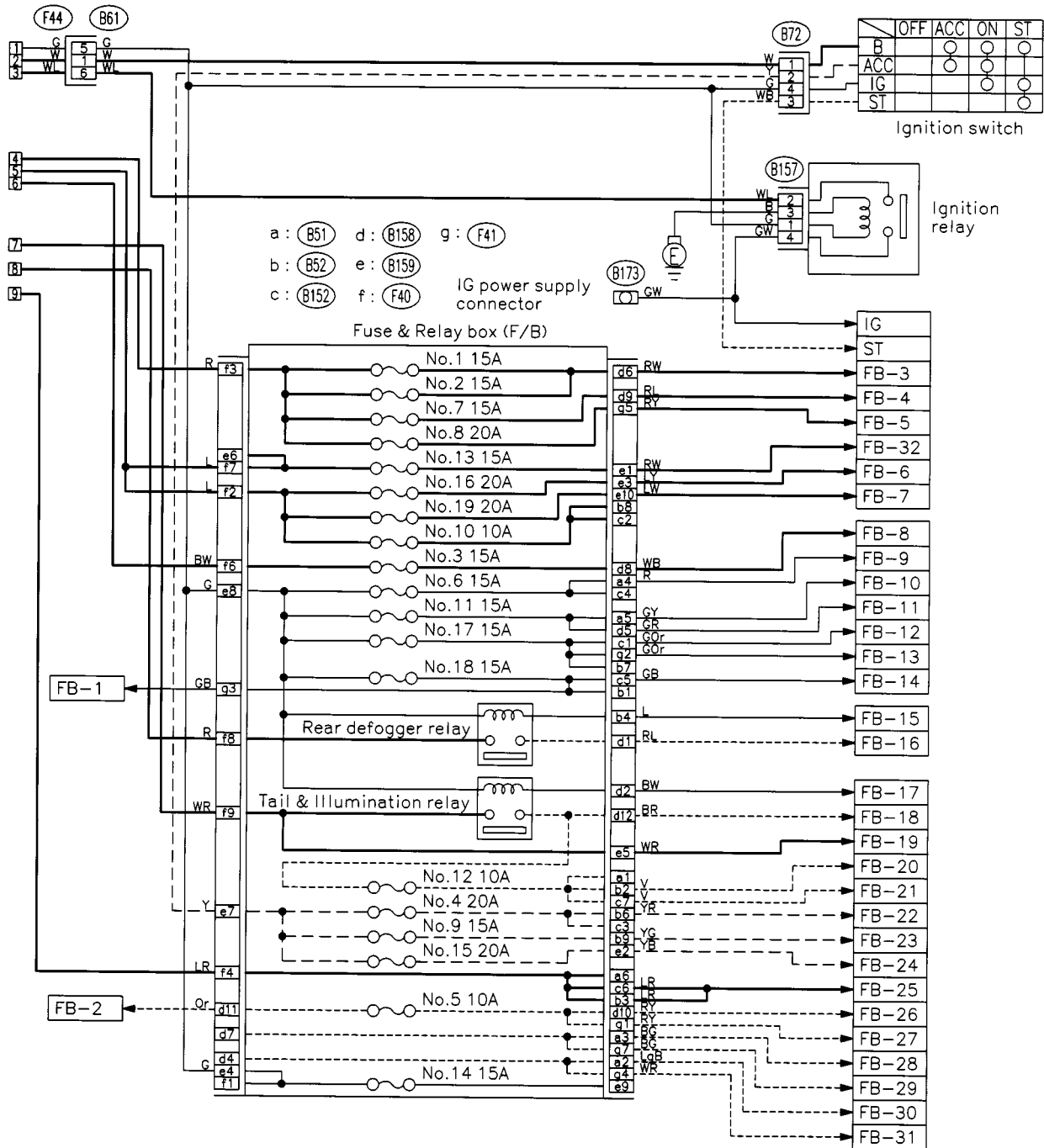

(B72) (Blue) c: (B152) b: (B52) (Blue)
 (B61) (B157) (Red) g: (F41) (Gray) a: (B51) (Blue) f: (F40) (Brown) e: (B159) (Gray) d: (B158)

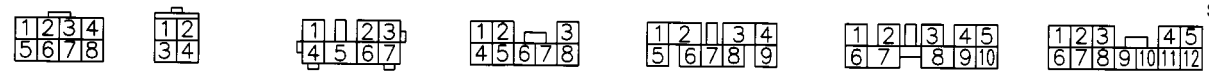

SU01-04B

SU01-04B

5. Wiring Diagram

No.	Load
MB-1	Power window circuit breaker
MB-2	Data link connector Engine control module Fuel pump relay Main relay OBD-II service connector
MB-3	Diode (Daytime running light) (Daytime running light control module) Lighting switch
MB-4	Cruise control sub switch Horn switch
MB-5	Transmission control module
MB-6	AT shift lock control module Hazard switch Key warning switch
MB-7	Horn
MB-8	Headlight LH
MB-9	Combination meter Front fog light relay Front fog light switch Headlight RH
MB-10	A/C relay holder
SBF-7	ABS control module
ALT-1	Combination meter Daytime running light control module
IG	Check connector Combination meter Hazard switch Key warning module Mirror heater LH Mirror heater RH Power window relay Vehicle speed sensor
ST	Engine control module Interrupt relay
FB-1	ABS control module Main fan relay
FB-2	Parking switch
FB-3	Blower motor relay
FB-4	Front fog light relay
FB-5	ABS control module
FB-6	Stop light switch
FB-7	Seat heater/rear accessory power supply relay
FB-8	Keyless entry control module
FB-9	Airbag control module
FB-10	Airbag control module
FB-11	Engine control module Fuel pump relay Ignition coil Transmission control module
FB-12	Blower motor relay Mode control panel Rear defogger switch
FB-13	A/C relay Sub fan relay

No.	Load
FB-14	AT shift lock control module Back-up light switch (MT) Cruise control main switch Cruise control module Daytime running light control module Daytime running light relay Hi-beam relay Inhibitor switch (AT) Keyless entry control module Security control module Wiper deicer relay Wiper deicer timer
FB-15	Rear defogger switch
FB-16	Mirror heater relay Rear defogger Rear defogger switch
FB-17	Lighting switch
FB-18	Front fog light switch Parking switch
FB-19	Parking switch Security control module
FB-20	Illumination light Illumination control module Keyless entry control module
FB-21	Illumination light Illumination control module Keyless entry control module
FB-22	AT shift lock control module Front accessory power supply Remote control rearview mirror switch Seat heater/rear accessory power supply relay
FB-23	Clock Noise killer Radio
FB-24	Front washer motor Front wiper motor Front wiper & washer switch Rear washer motor Rear wiper intermittent module Rear wiper motor
FB-25	Clock Combination meter Compass mirror Luggage room light Radio Room light Security control module Spot light Trailer connector
FB-26	License plate light Tail light LH Tail light RH Trailer connector
FB-27	Front clearance light LH Front clearance light RH

No.	Load
FB-28	Combination meter Hazard switch Rear turn signal light LH Trailer connector Turn signal switch
FB-29	Front turn signal light LH
FB-30	Combination meter Hazard switch Rear turn signal light RH Trailer connector Turn signal switch
FB-31	Front turn signal light RH
FB-32	Wiper deicer relay

B: GROUND DISTRIBUTION

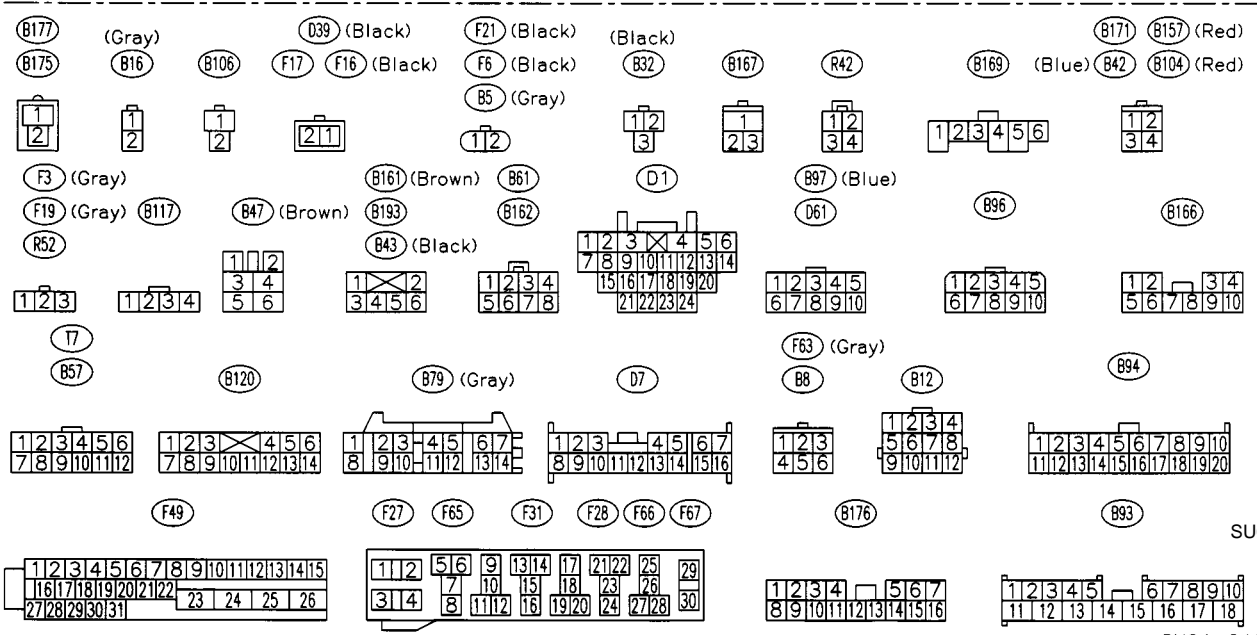
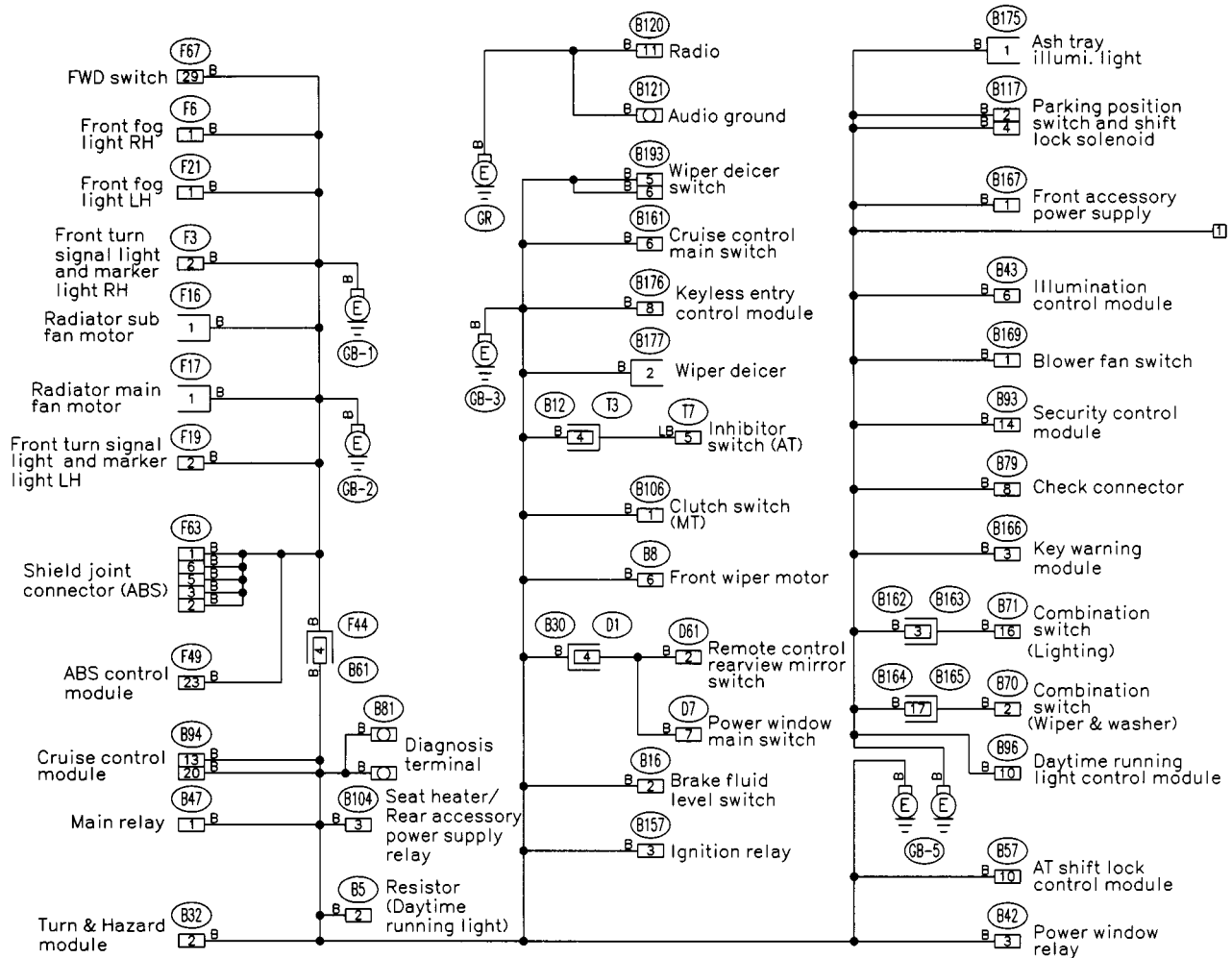

SU04-04A

SU04-04A

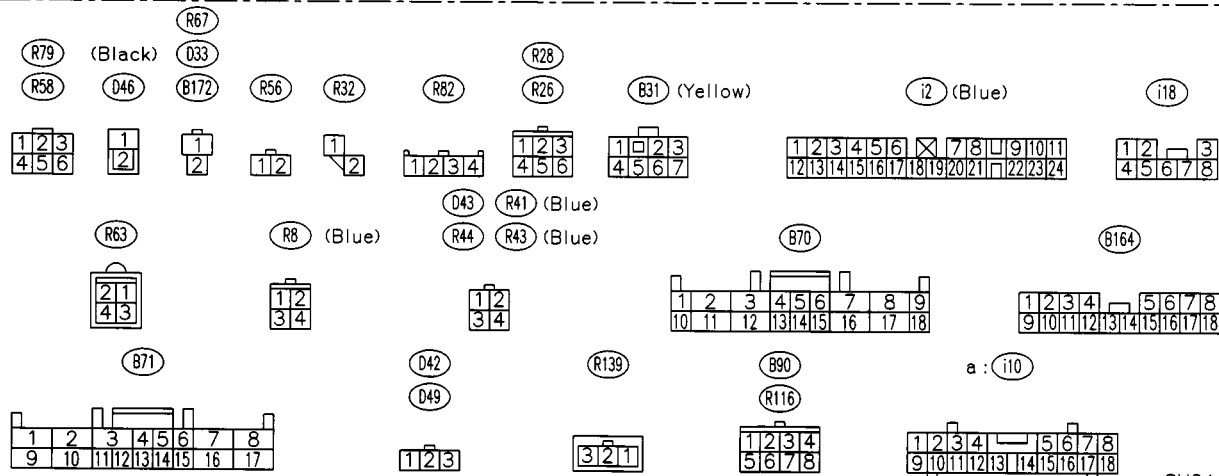
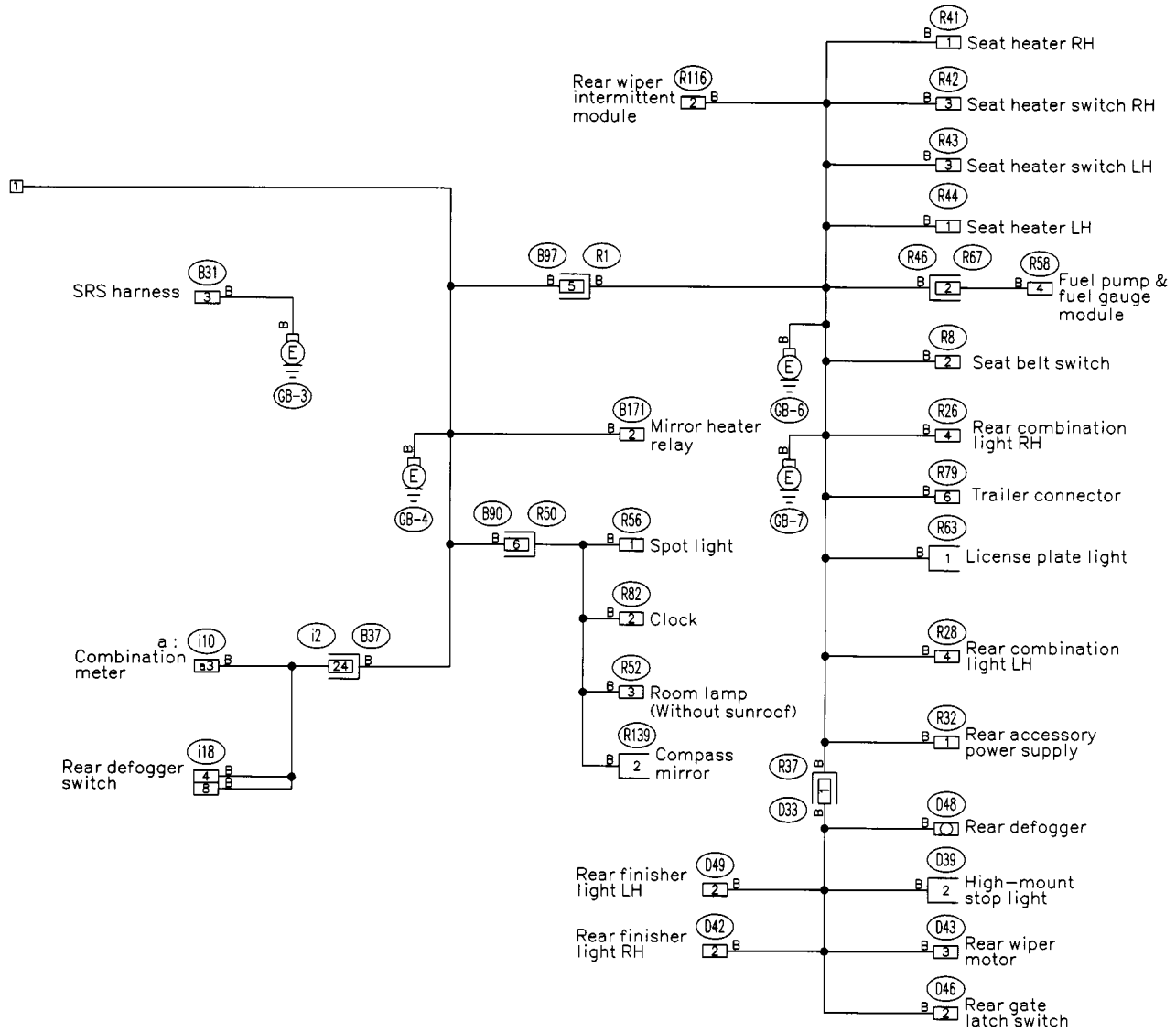

SU04-04B

SU04-04B

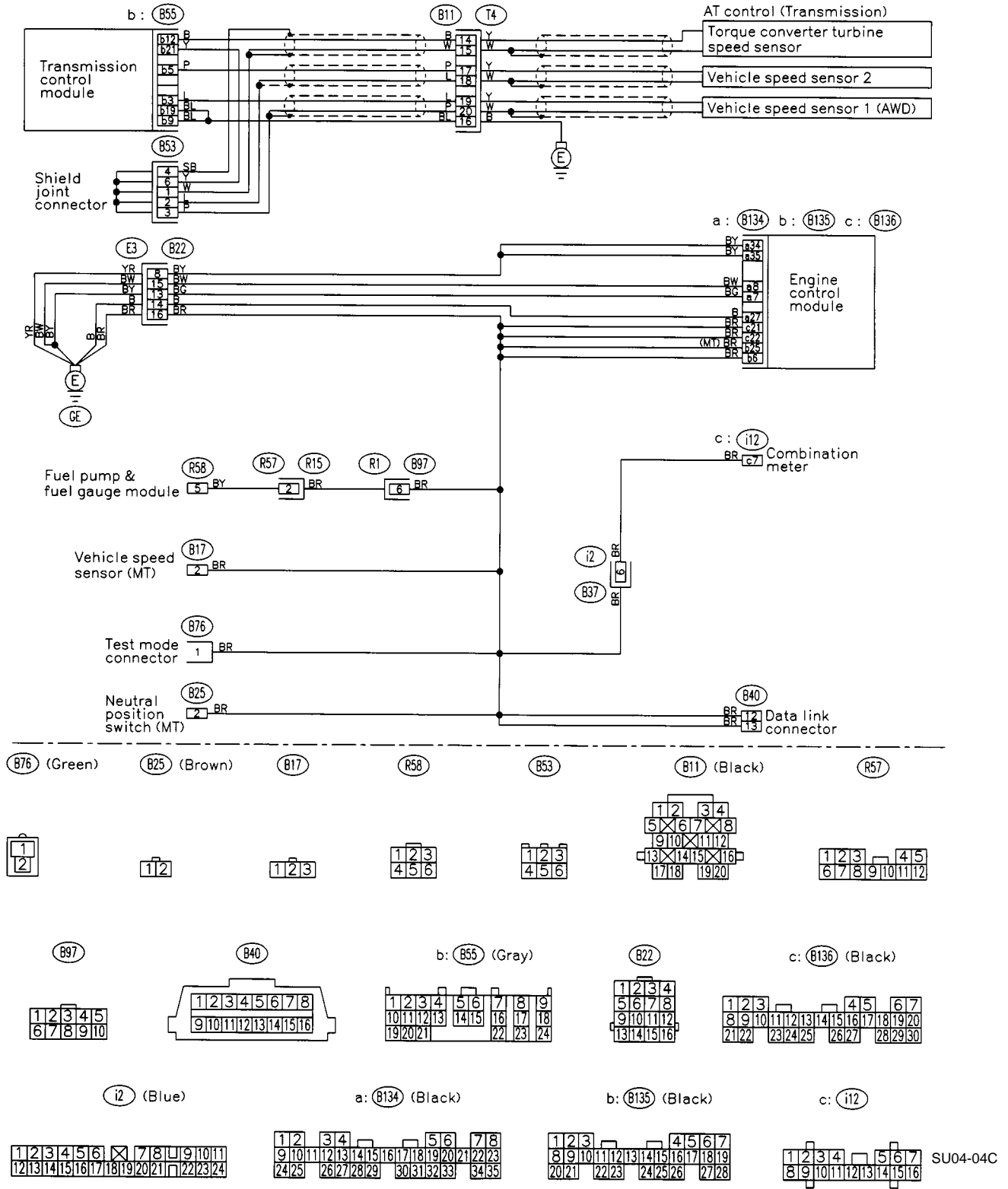

C: AIRBAG SYSTEM

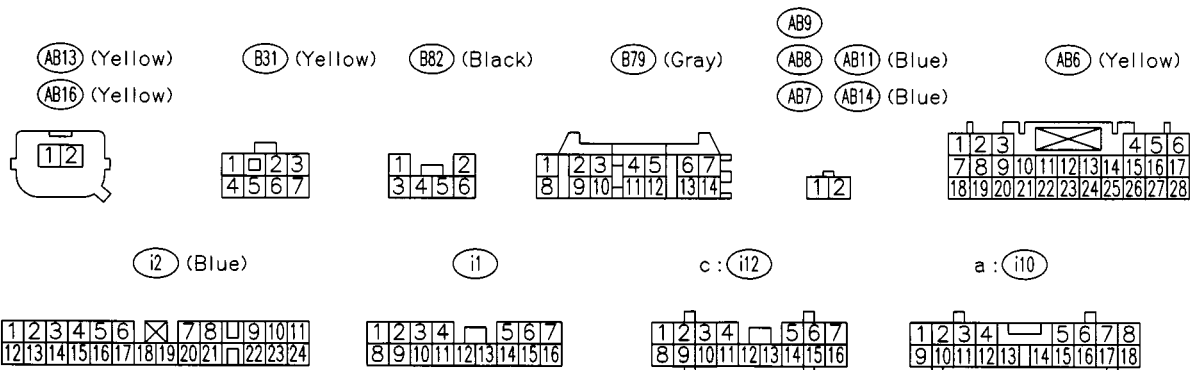
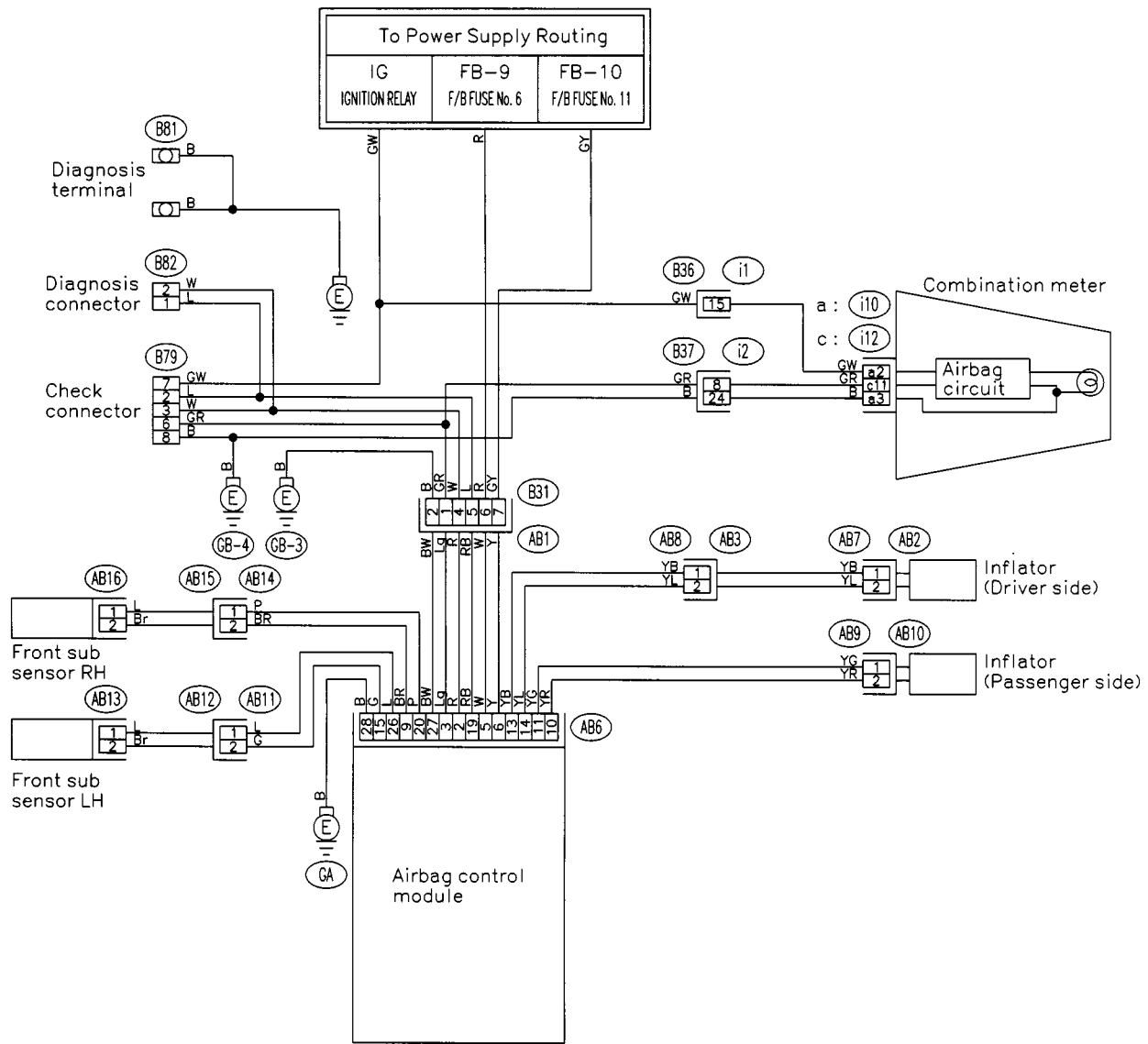

SU86-05

SU86-05

D: AIR CONDITIONING SYSTEM

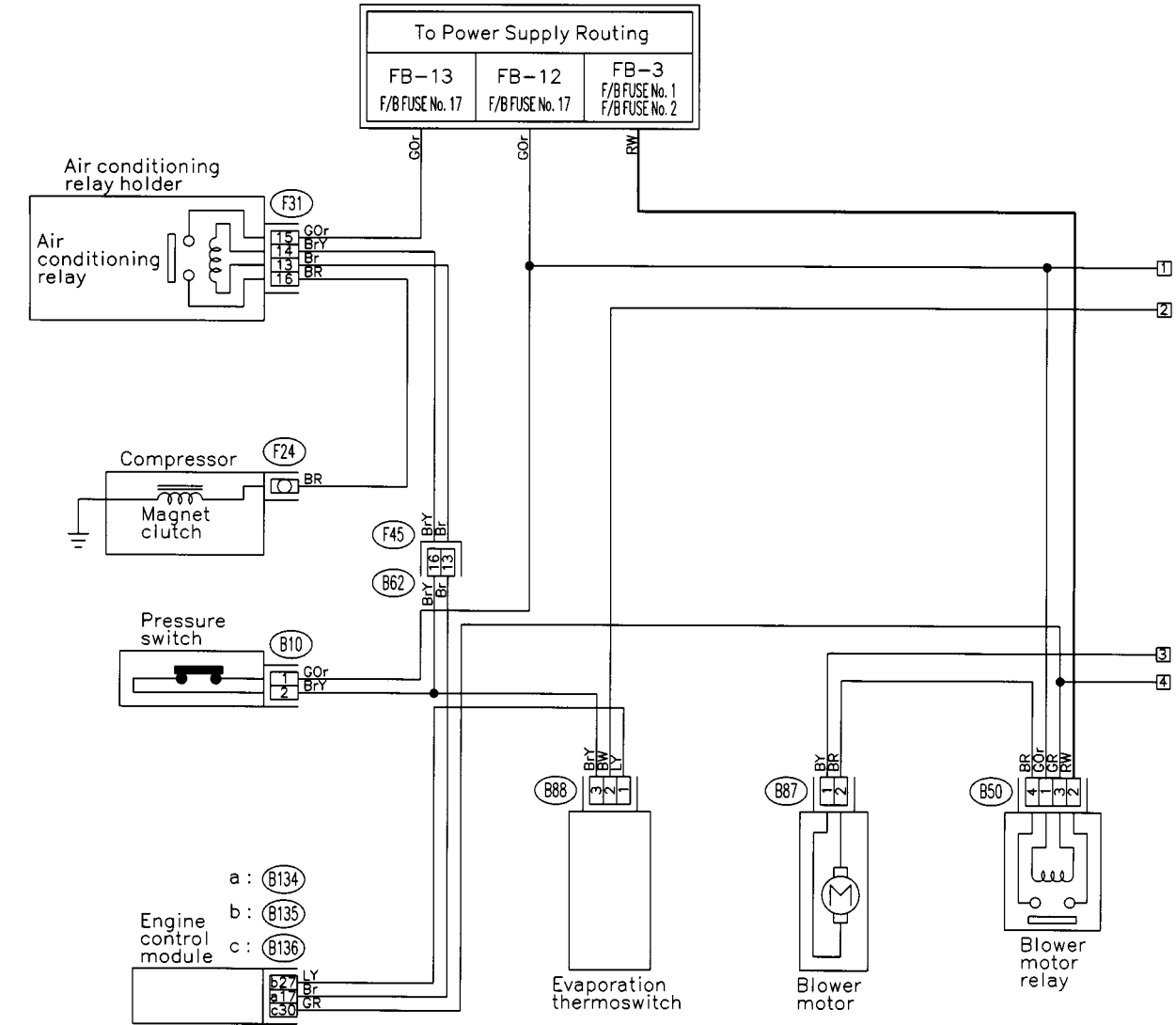

Engine control module
a: (B134)
b: (B135)
c: (B136)

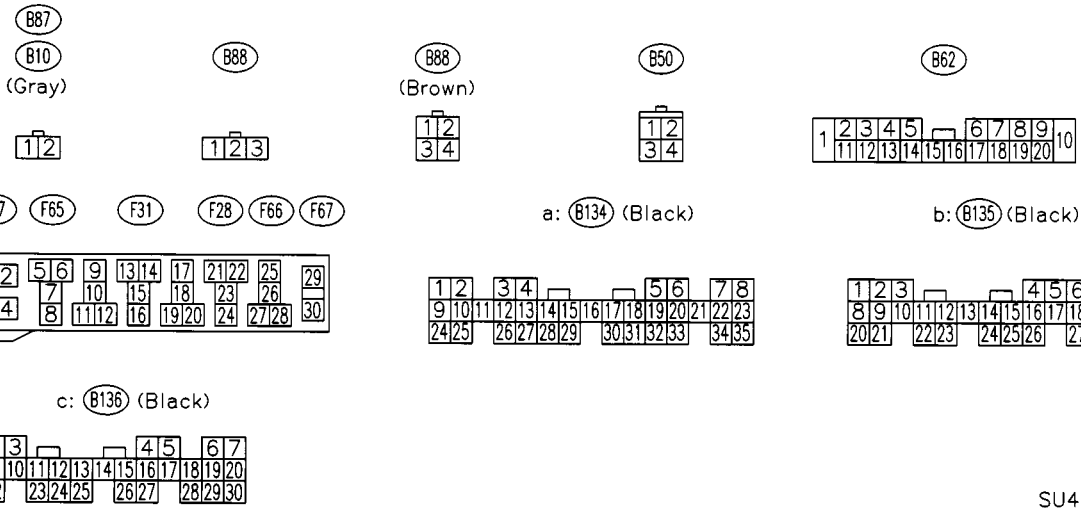

SU45-04A

SU45-04A

E: ANTI-LOCK BRAKE SYSTEM

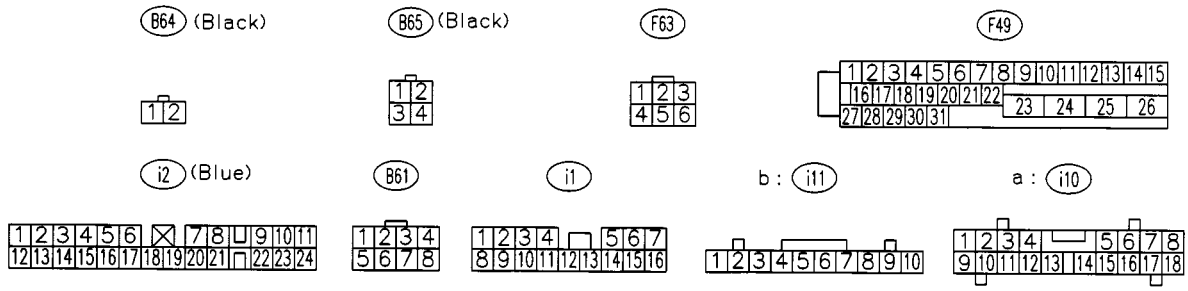
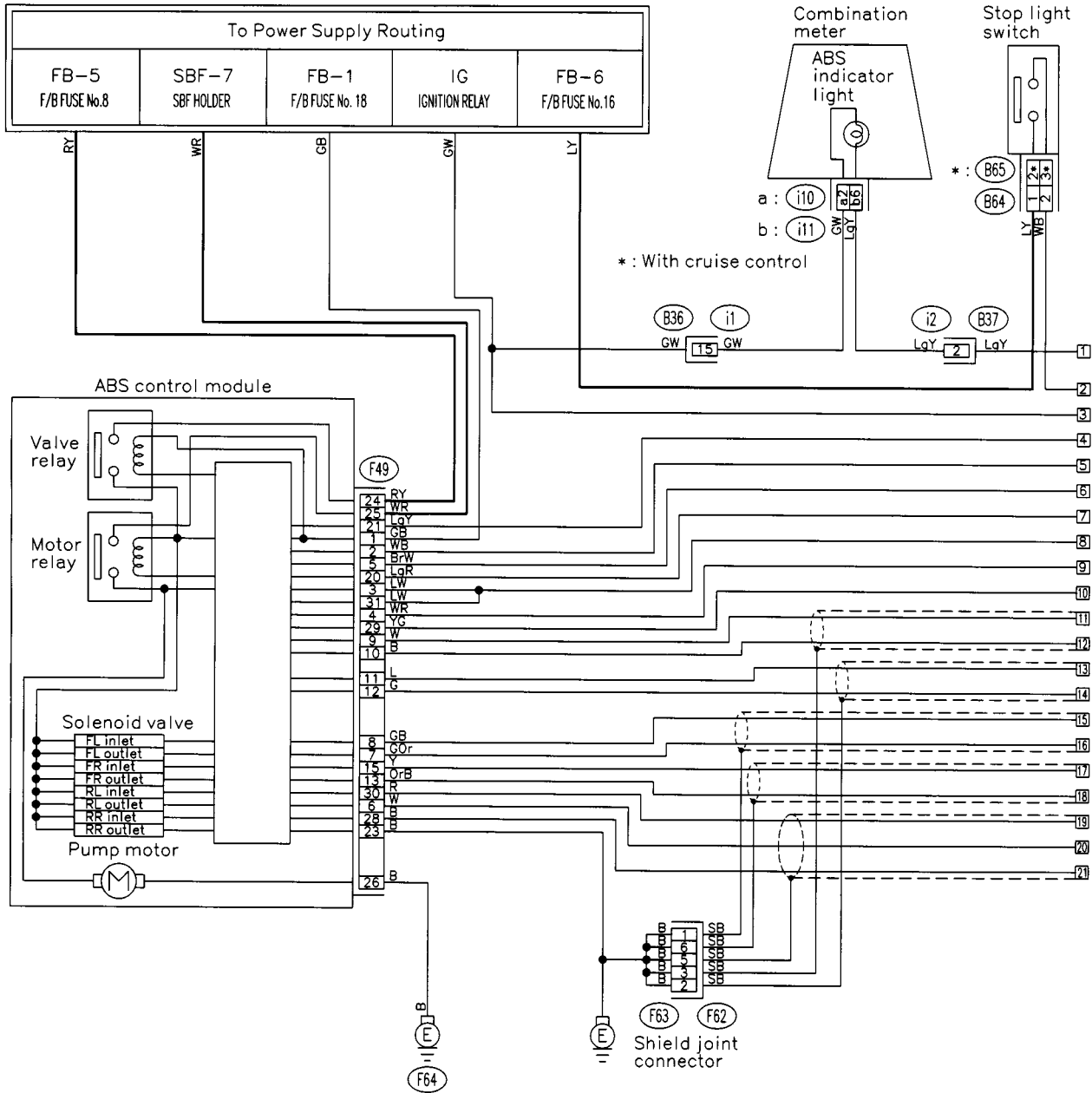

SU82-04A
SU82-04A

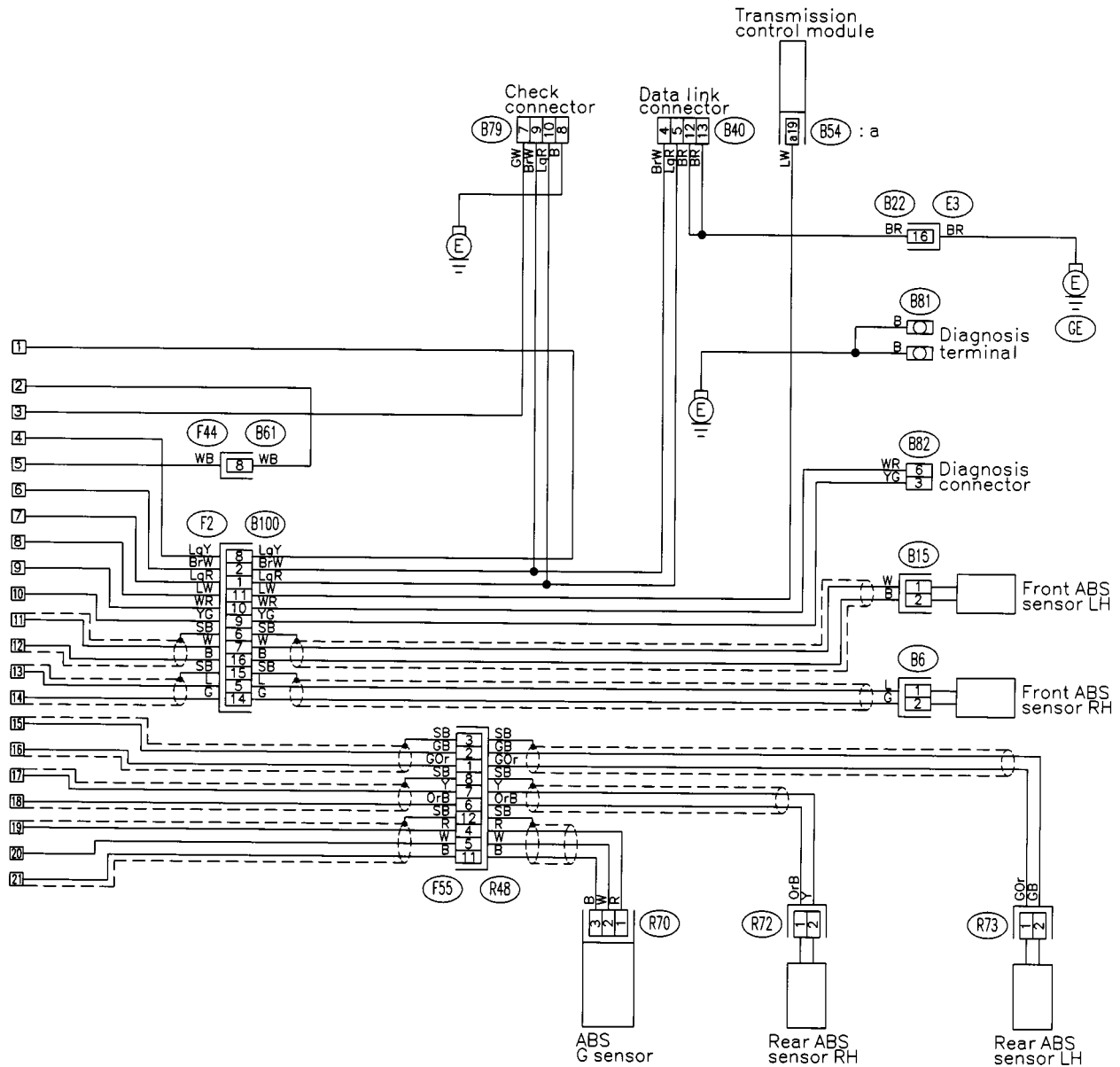

(Brown) B6 B15 (Brown)

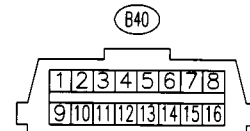
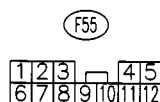
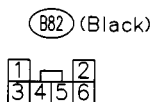
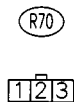
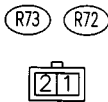

B22

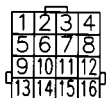

B79 (Gray)

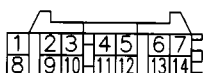

B100 (Black)

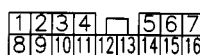

a : B54

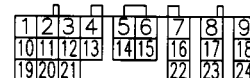

SU82-04B

SU82-04B

F: A/T CONTROL SYSTEM

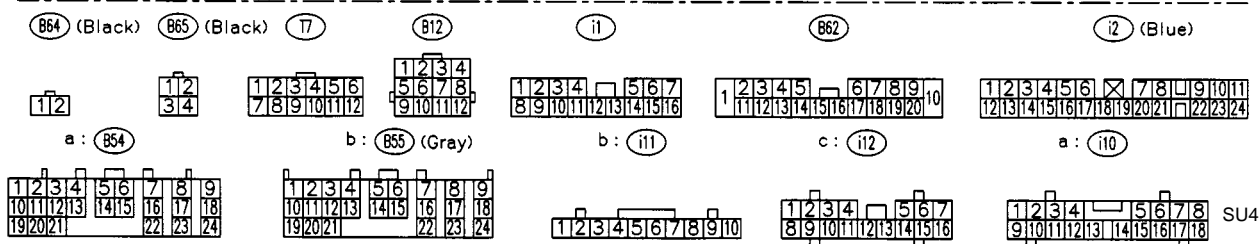
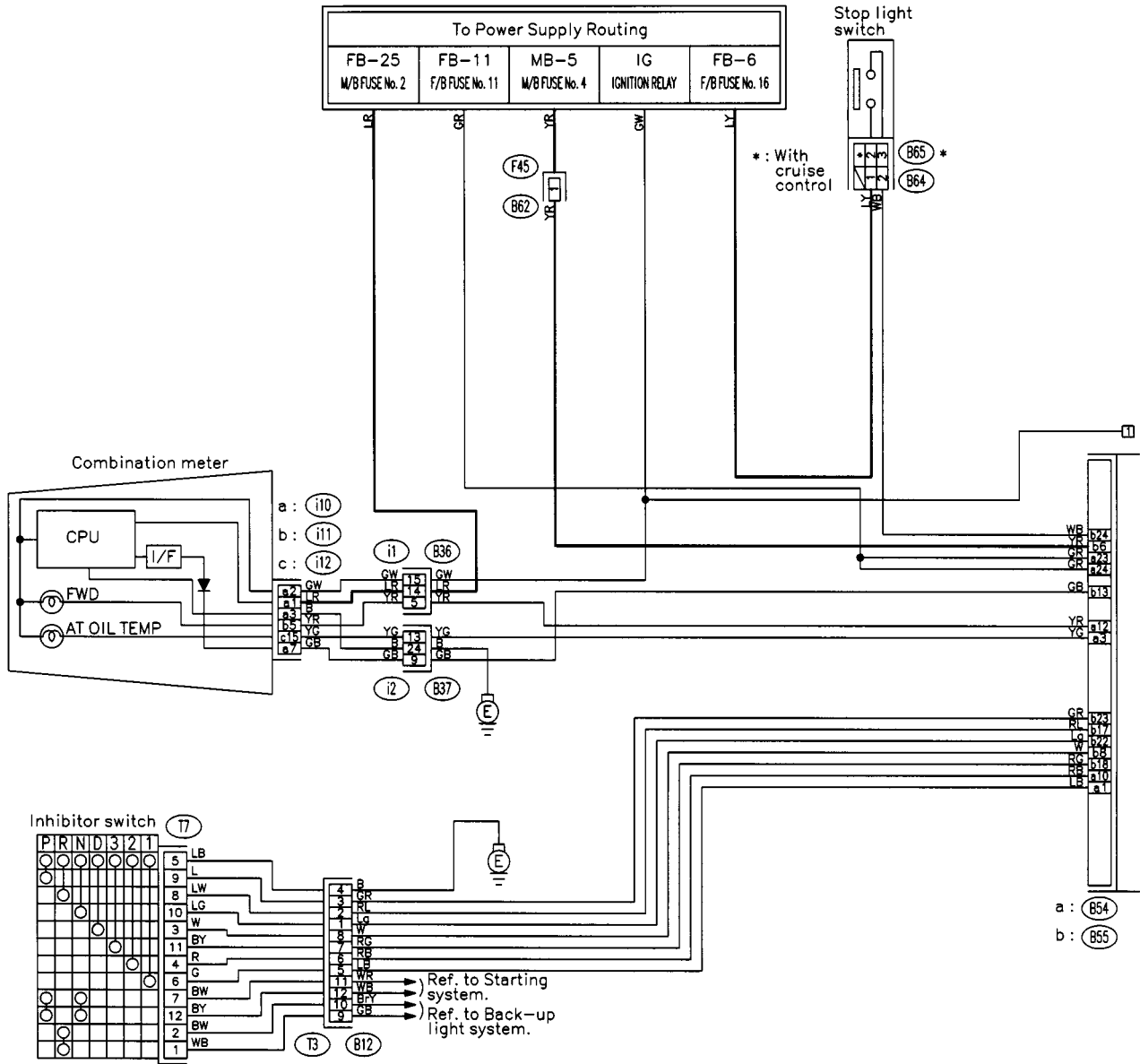

SU41-06A
SU41-06A

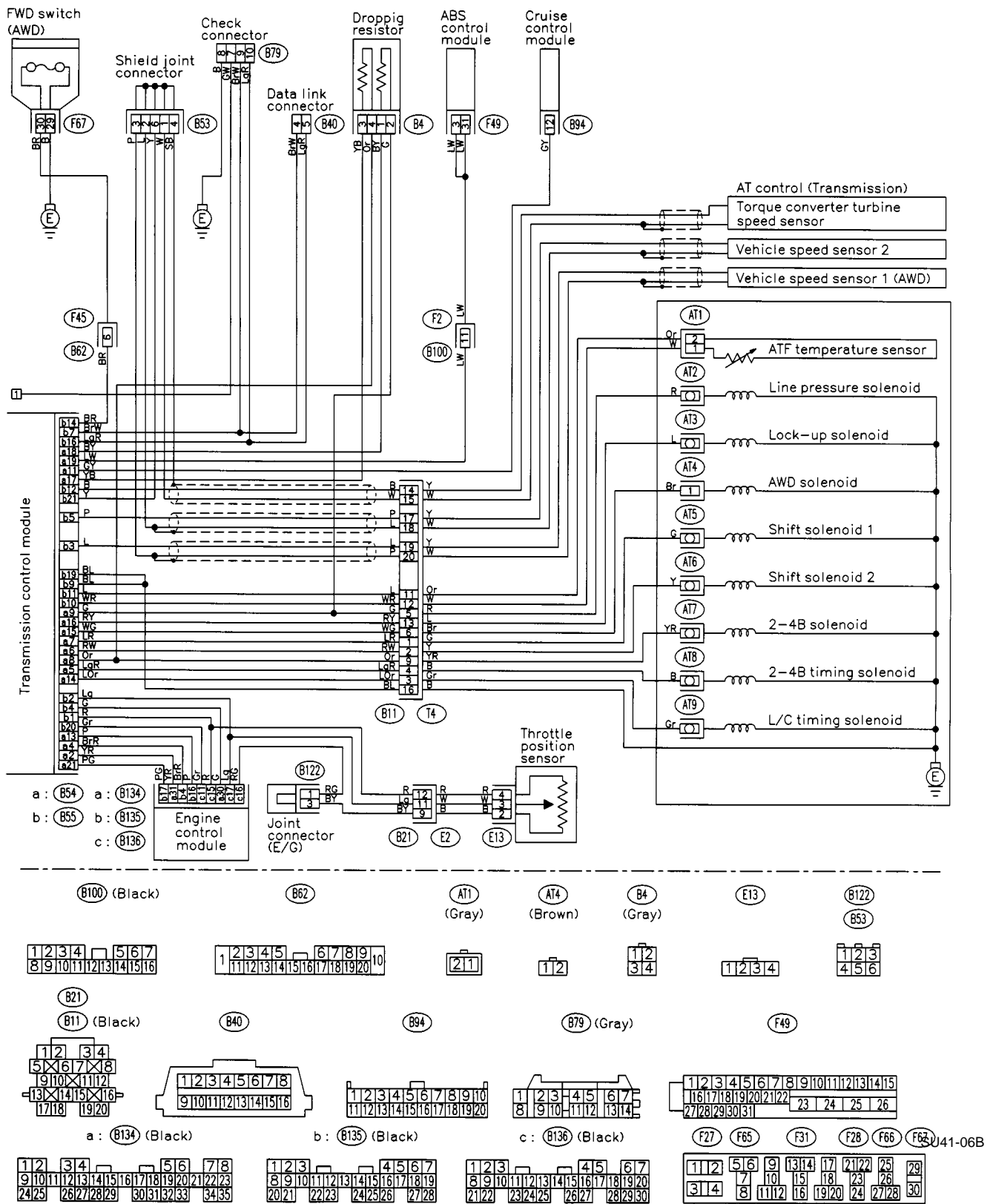

G: A/T SHIFT LOCK SYSTEM

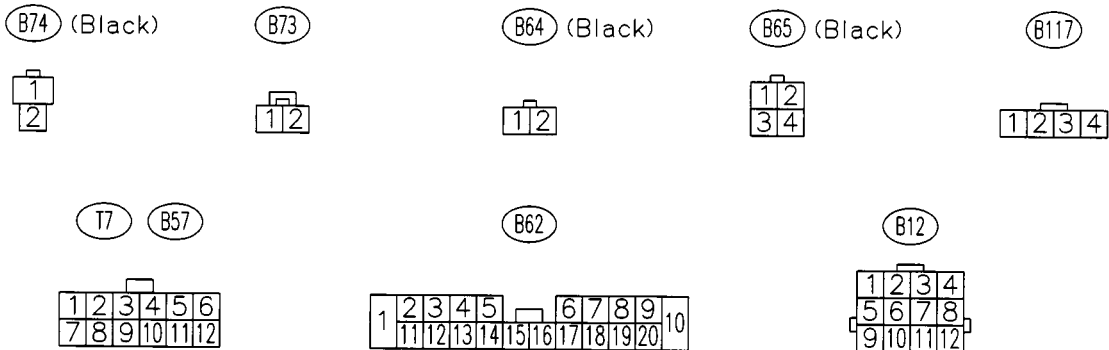
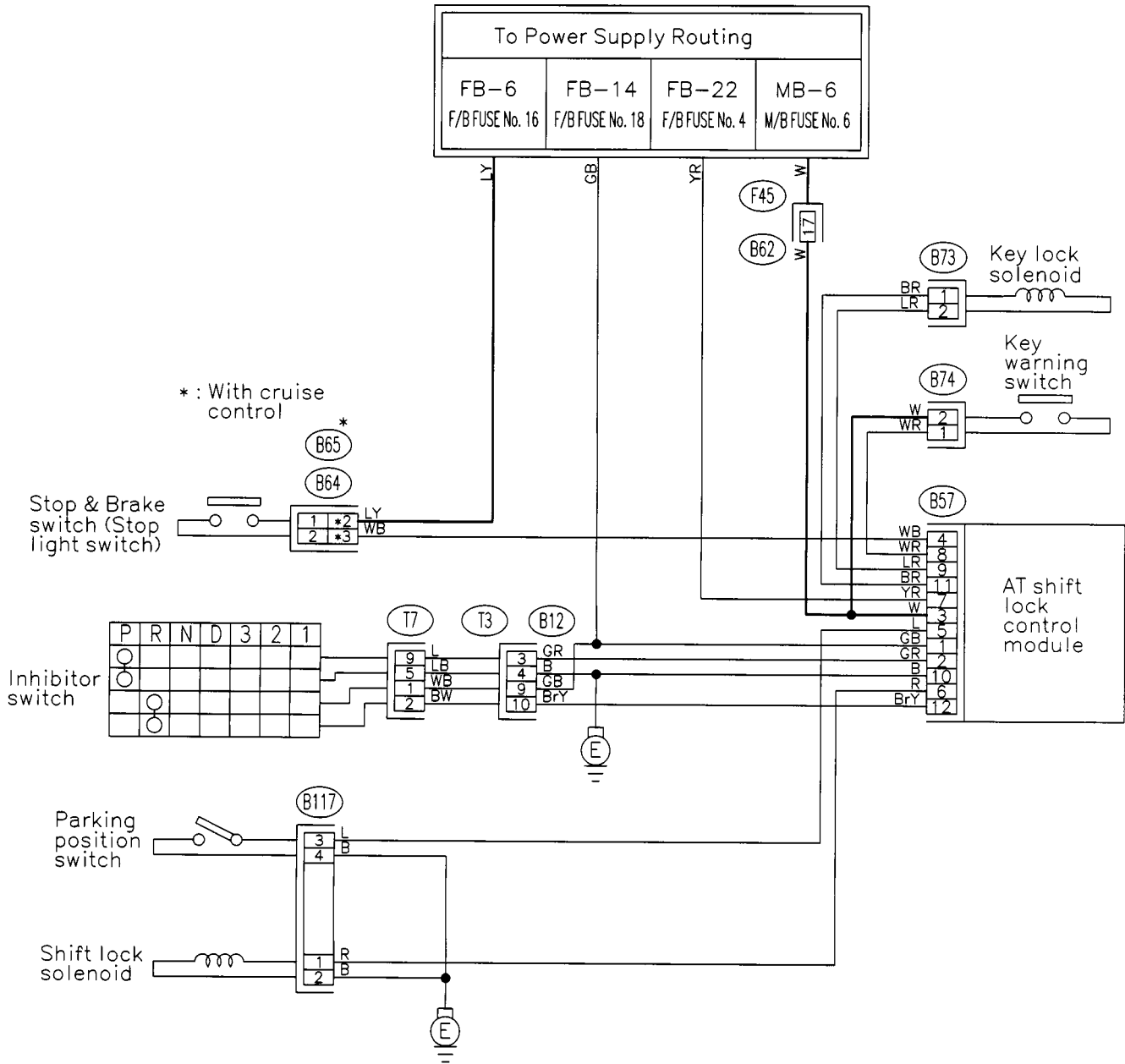

SU42-04

SU42-04

H: AUDIO SYSTEM

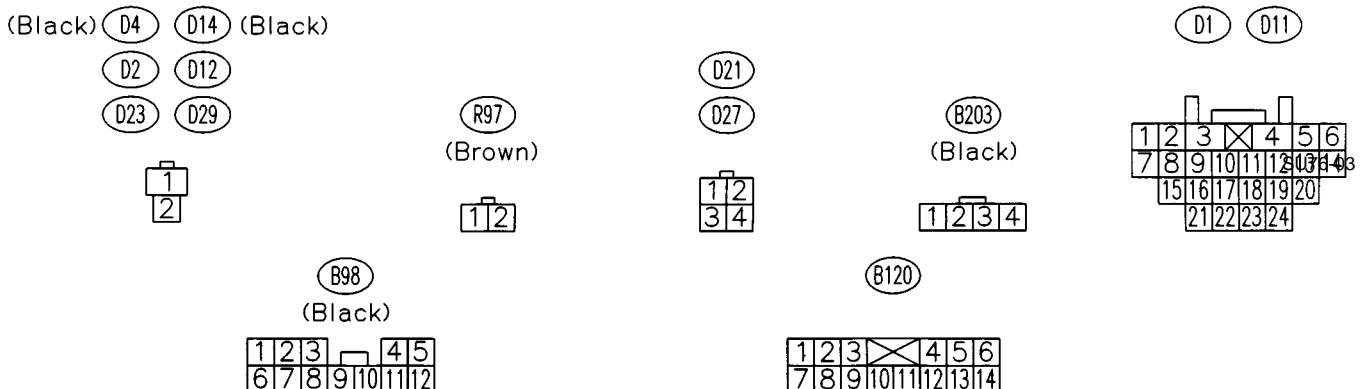
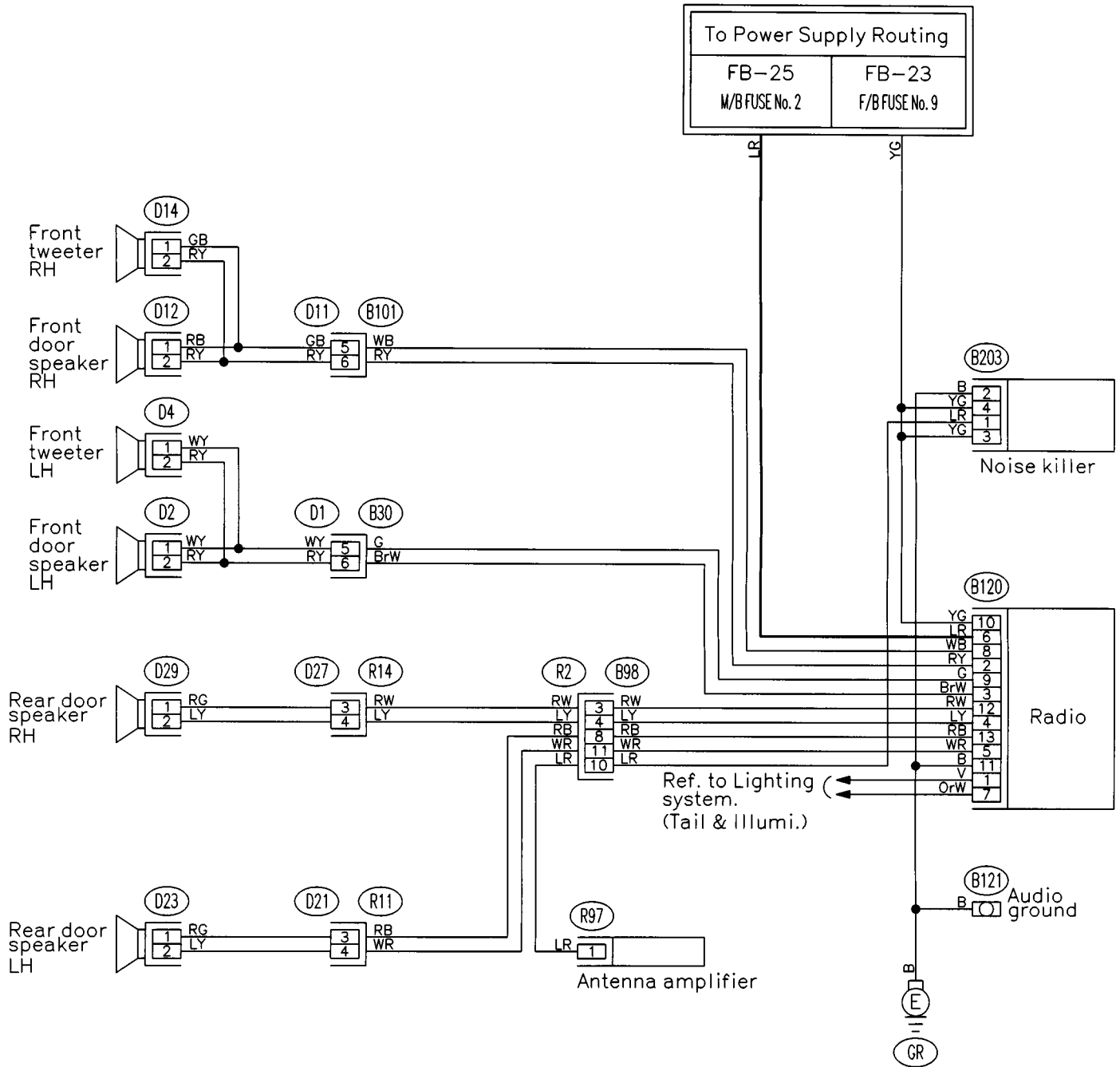

I: CHARGING SYSTEM

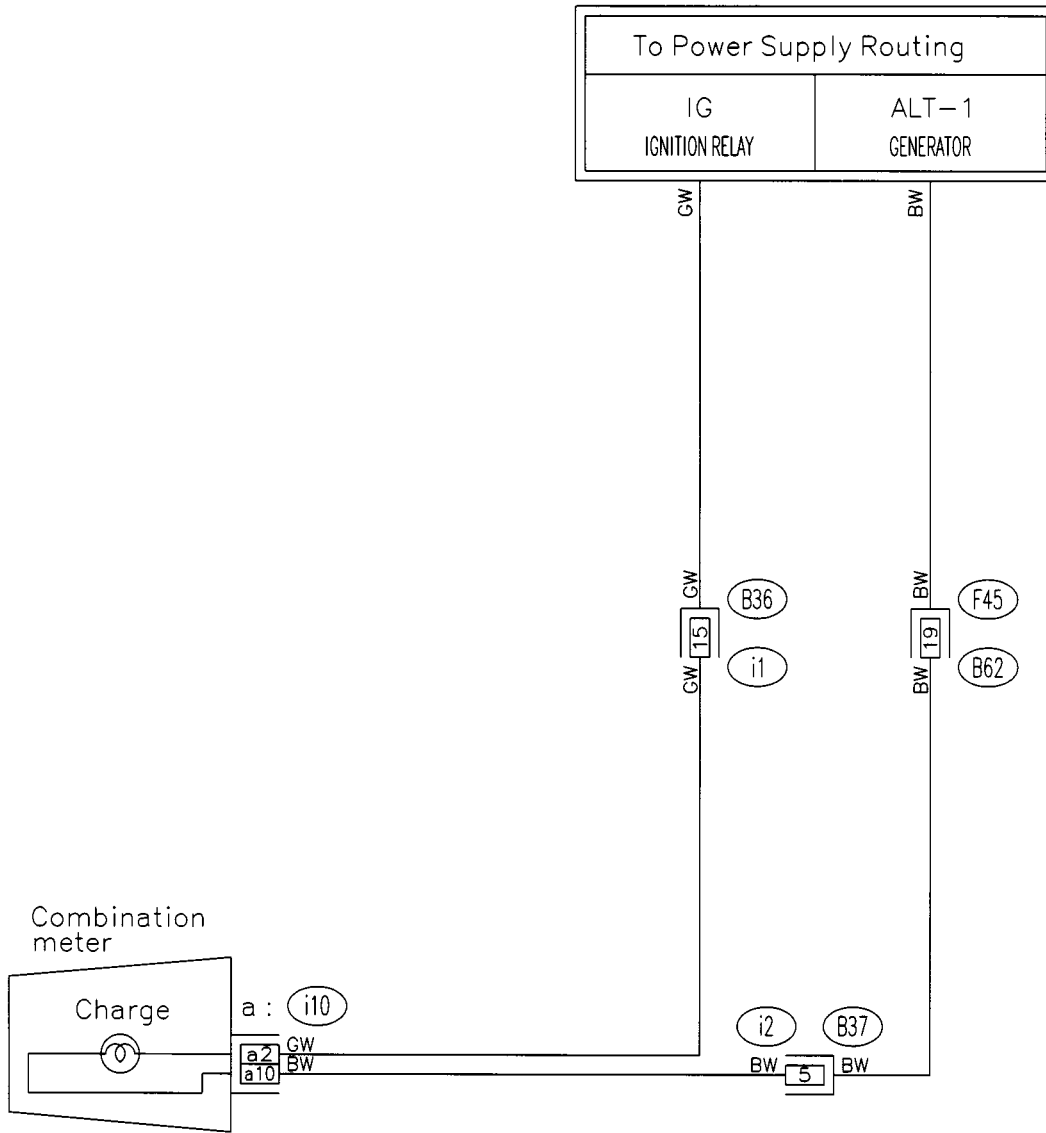

i1

1	2	3	4		5	6	7	
8	9	10	11	12	13	14	15	16

i2 (Blue)

1	2	3	4	5	6	⊗	7	8	9	10	11		
12	13	14	15	16	17	18	19	20	21	□	22	23	24

B62

1	2	3	4	5		6	7	8	9	10
11	12	13	14	15	16	17	18	19	20	

a : i10

1	2	3	4		5	6	7	8	
9	10	11	12	13	14	15	16	17	18

SU02-03

SU02-03

J: COMBINATION METER

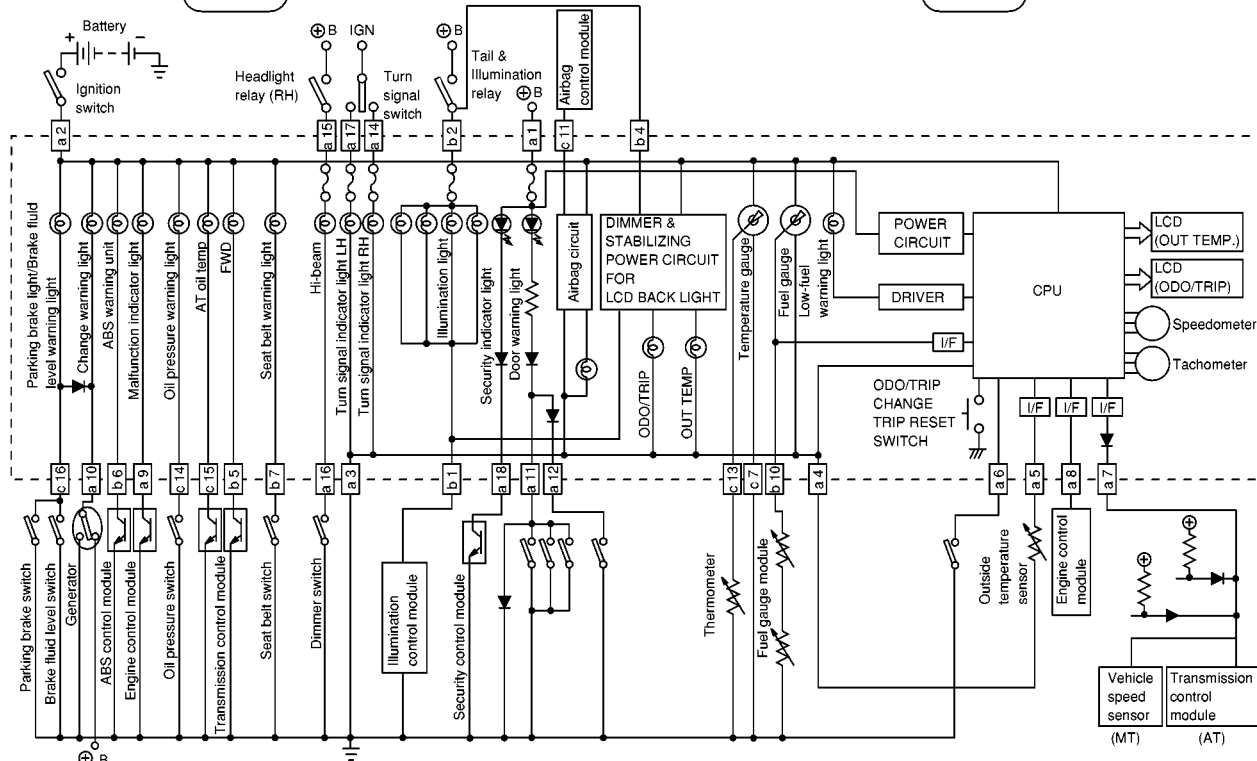
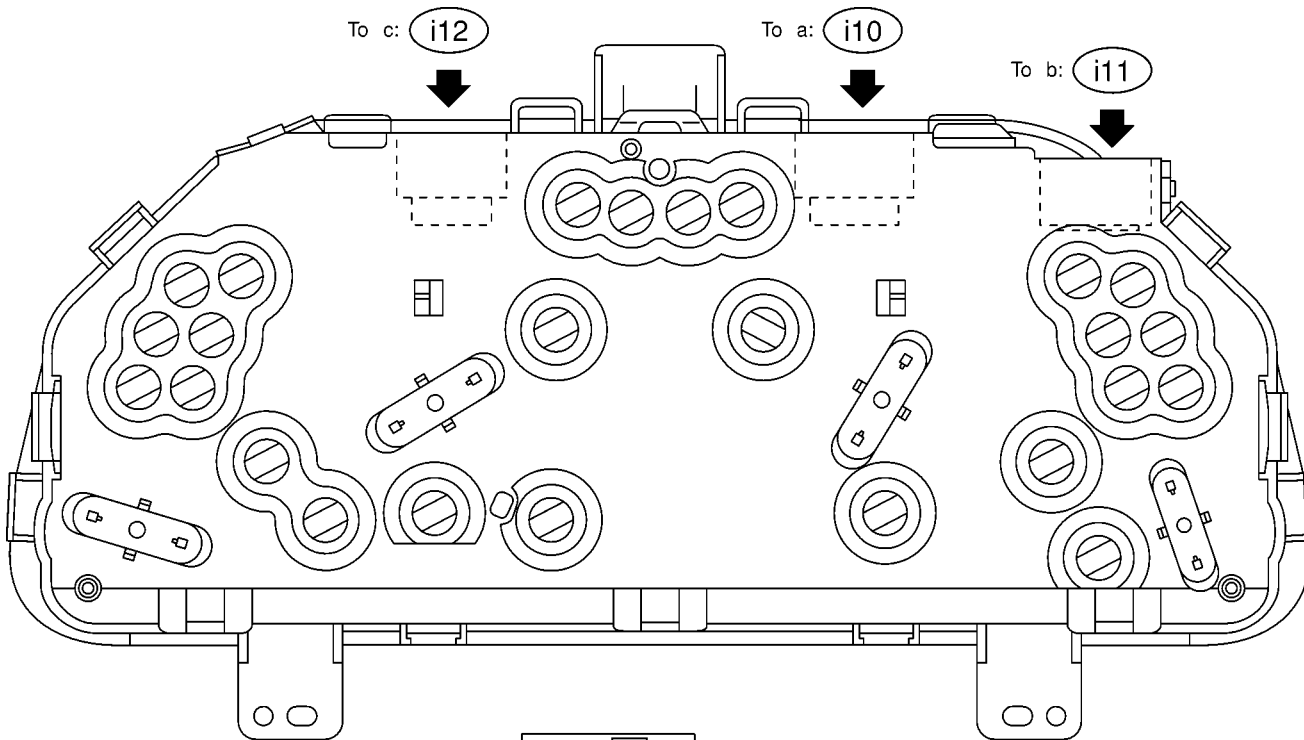

SU64-03

K: COMPASS MIRROR SYSTEM

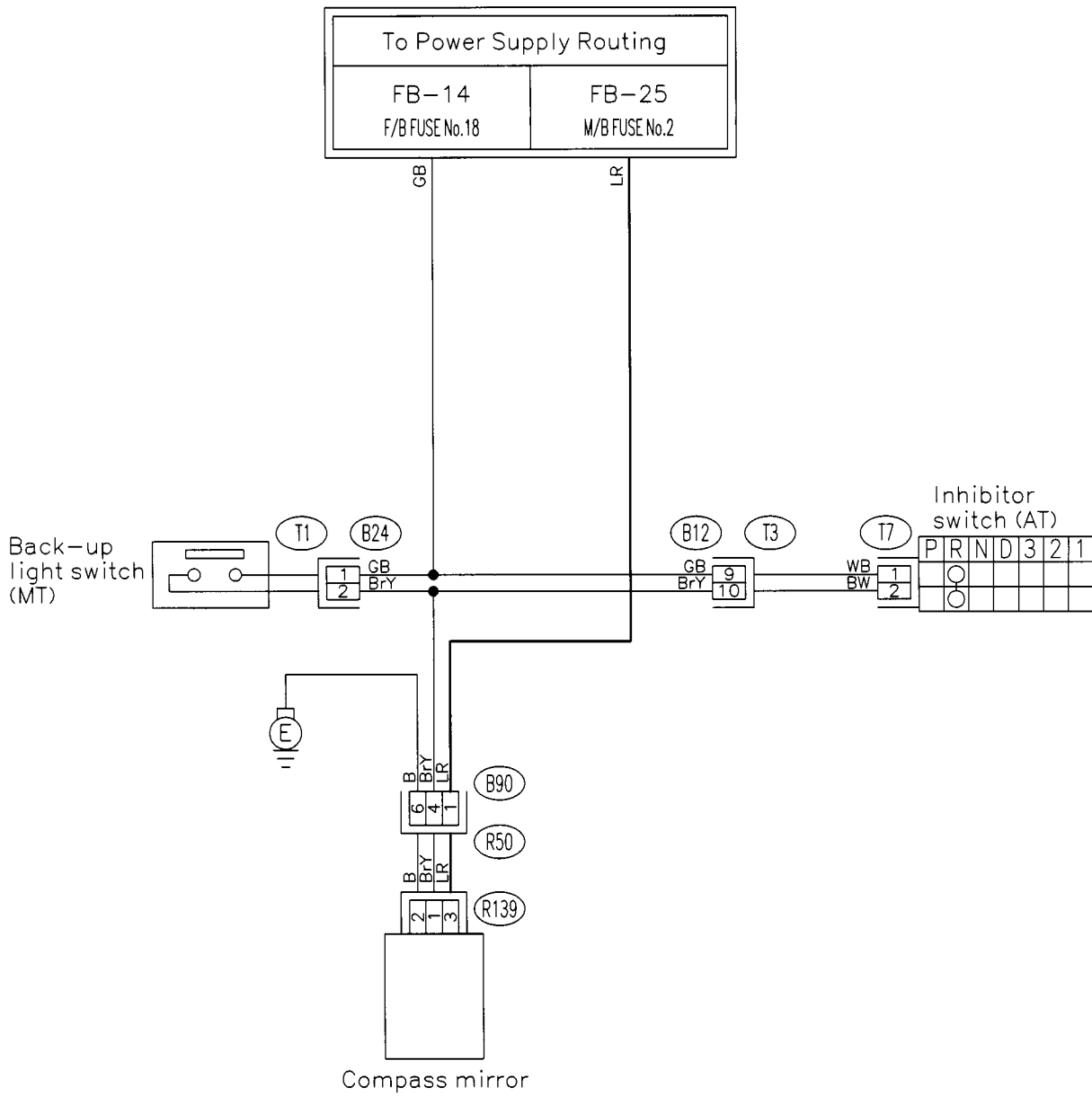

(B24) (Gray)

(R139)

(B12)

(B90)

(T7)

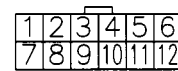
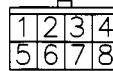
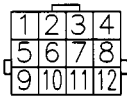
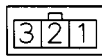

SU97-01

SU97-01

M: ENGINE ELECTRICAL SYSTEM

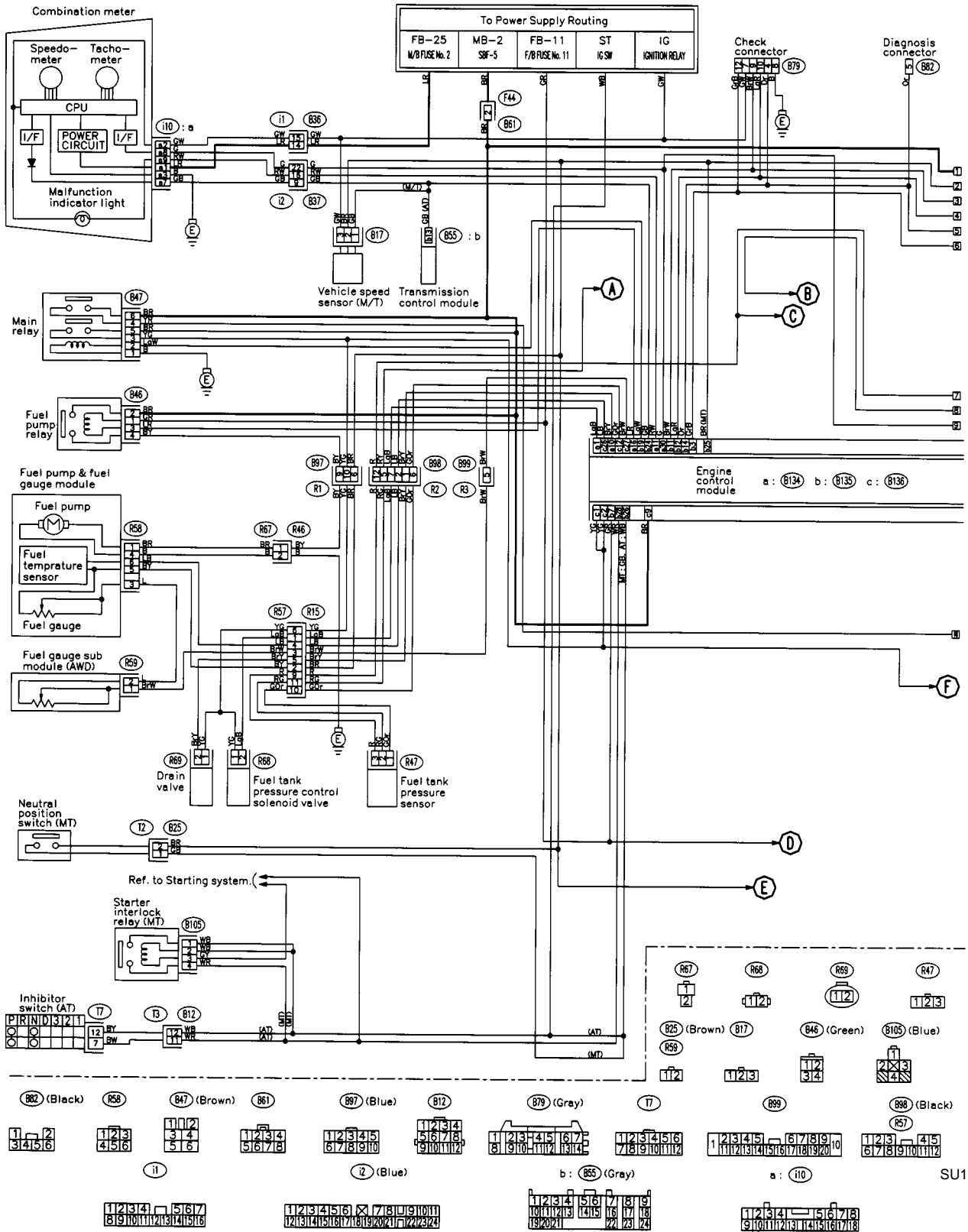

SU10-07A

SU10-07A

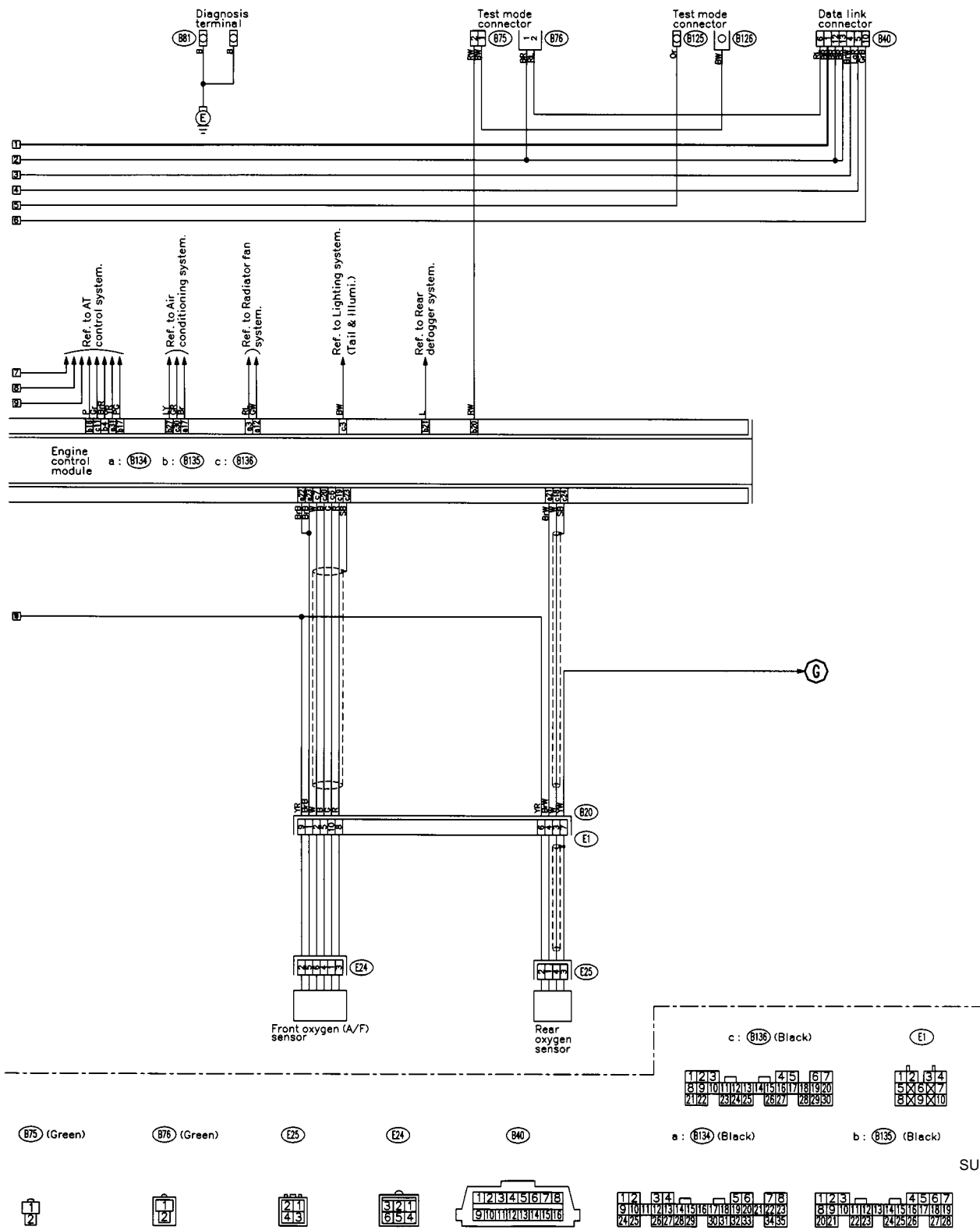

SU10-07B

SU10-07B

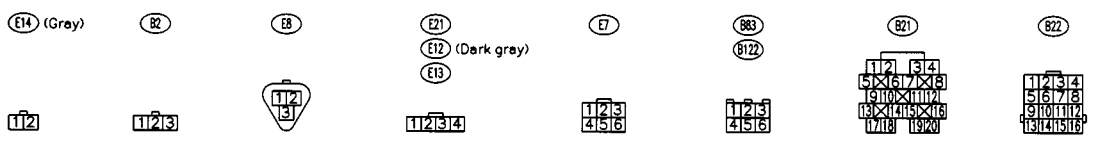
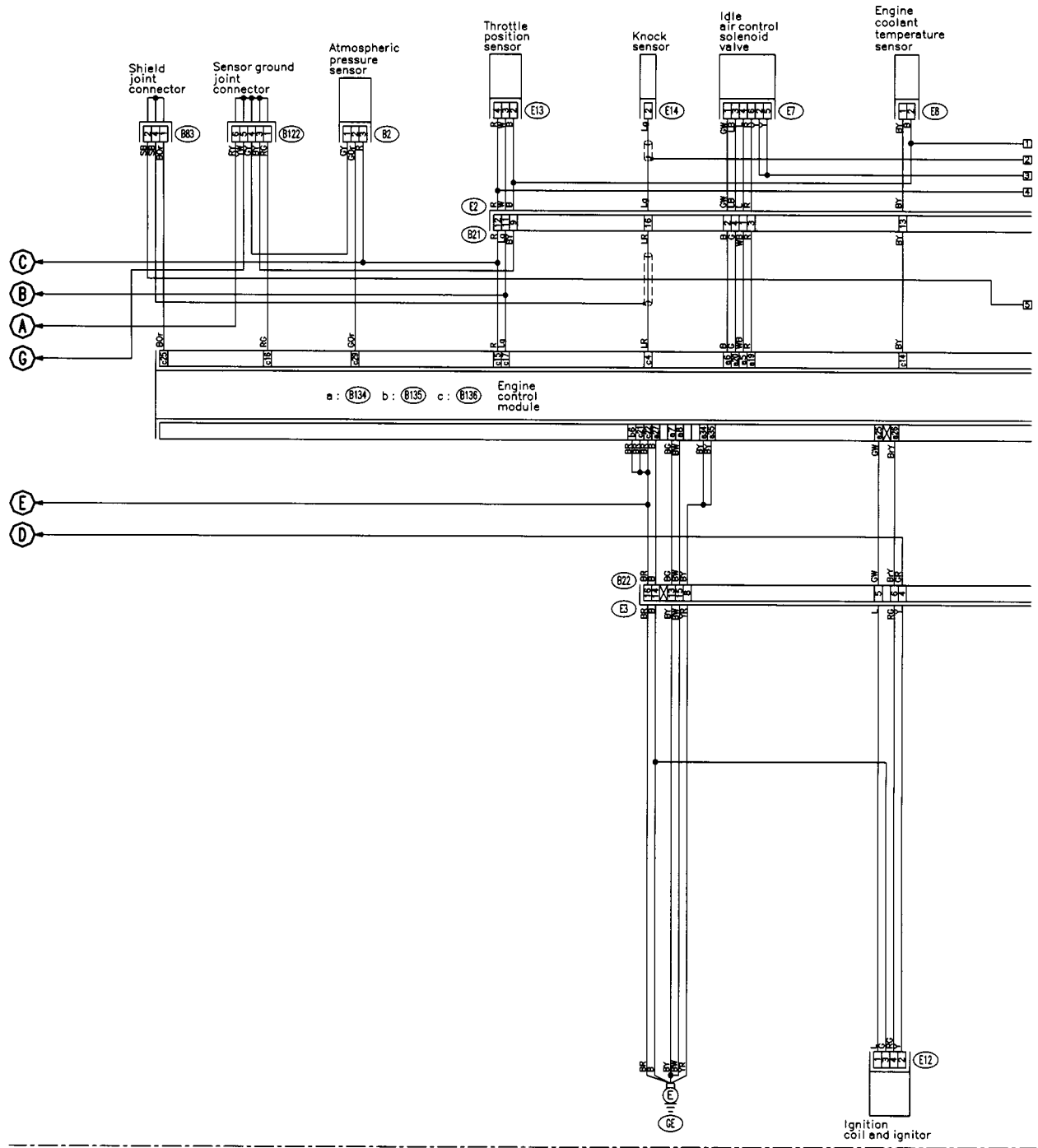

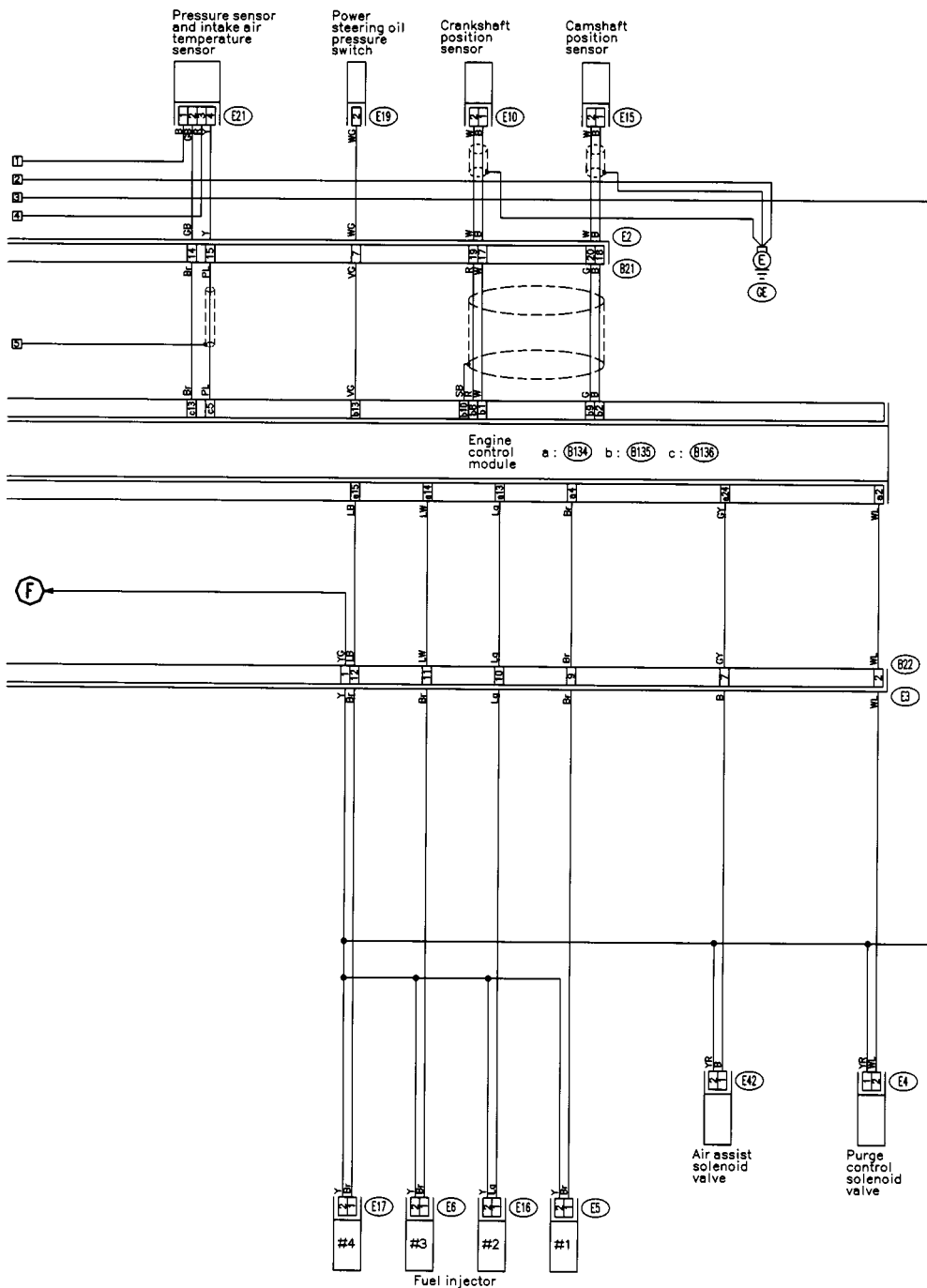

<p>(E5)</p> <p>(E6)</p> <p>(E16)</p> <p>(E17)</p>	<p>(E10)</p> <p>(E15)</p> <p>(E42)</p> <p>(E19)</p> <p>(E4)</p>	<p>b: (E135) (Black)</p> <table border="1" style="font-size: small; border-collapse: collapse; width: 100%;"> <tr><td>1</td><td>2</td><td>3</td><td>4</td><td>5</td><td>6</td><td>7</td></tr> <tr><td>8</td><td>9</td><td>10</td><td>11</td><td>12</td><td>13</td><td>14</td></tr> <tr><td>15</td><td>16</td><td>17</td><td>18</td><td>19</td><td>20</td><td>21</td></tr> <tr><td>22</td><td>23</td><td>24</td><td>25</td><td>26</td><td>27</td><td>28</td></tr> </table>	1	2	3	4	5	6	7	8	9	10	11	12	13	14	15	16	17	18	19	20	21	22	23	24	25	26	27	28	<p>c: (E136) (Black)</p> <table border="1" style="font-size: small; border-collapse: collapse; width: 100%;"> <tr><td>1</td><td>2</td><td>3</td><td>4</td><td>5</td><td>6</td><td>7</td></tr> <tr><td>8</td><td>9</td><td>10</td><td>11</td><td>12</td><td>13</td><td>14</td></tr> <tr><td>15</td><td>16</td><td>17</td><td>18</td><td>19</td><td>20</td><td>21</td></tr> <tr><td>22</td><td>23</td><td>24</td><td>25</td><td>26</td><td>27</td><td>28</td></tr> <tr><td>29</td><td>30</td><td>31</td><td>32</td><td>33</td><td>34</td><td>35</td></tr> </table>	1	2	3	4	5	6	7	8	9	10	11	12	13	14	15	16	17	18	19	20	21	22	23	24	25	26	27	28	29	30	31	32	33	34	35	<p>a: (E134) (Black)</p> <table border="1" style="font-size: small; border-collapse: collapse; width: 100%;"> <tr><td>1</td><td>2</td><td>3</td><td>4</td><td>5</td><td>6</td><td>7</td><td>8</td></tr> <tr><td>9</td><td>10</td><td>11</td><td>12</td><td>13</td><td>14</td><td>15</td><td>16</td></tr> <tr><td>17</td><td>18</td><td>19</td><td>20</td><td>21</td><td>22</td><td>23</td><td>24</td></tr> <tr><td>25</td><td>26</td><td>27</td><td>28</td><td>29</td><td>30</td><td>31</td><td>32</td></tr> <tr><td>33</td><td>34</td><td>35</td><td>36</td><td>37</td><td>38</td><td>39</td><td>40</td></tr> </table>	1	2	3	4	5	6	7	8	9	10	11	12	13	14	15	16	17	18	19	20	21	22	23	24	25	26	27	28	29	30	31	32	33	34	35	36	37	38	39	40
1	2	3	4	5	6	7																																																																																																					
8	9	10	11	12	13	14																																																																																																					
15	16	17	18	19	20	21																																																																																																					
22	23	24	25	26	27	28																																																																																																					
1	2	3	4	5	6	7																																																																																																					
8	9	10	11	12	13	14																																																																																																					
15	16	17	18	19	20	21																																																																																																					
22	23	24	25	26	27	28																																																																																																					
29	30	31	32	33	34	35																																																																																																					
1	2	3	4	5	6	7	8																																																																																																				
9	10	11	12	13	14	15	16																																																																																																				
17	18	19	20	21	22	23	24																																																																																																				
25	26	27	28	29	30	31	32																																																																																																				
33	34	35	36	37	38	39	40																																																																																																				

SU10-07D

SU10-07D

N: FUEL GAUGE SYSTEM

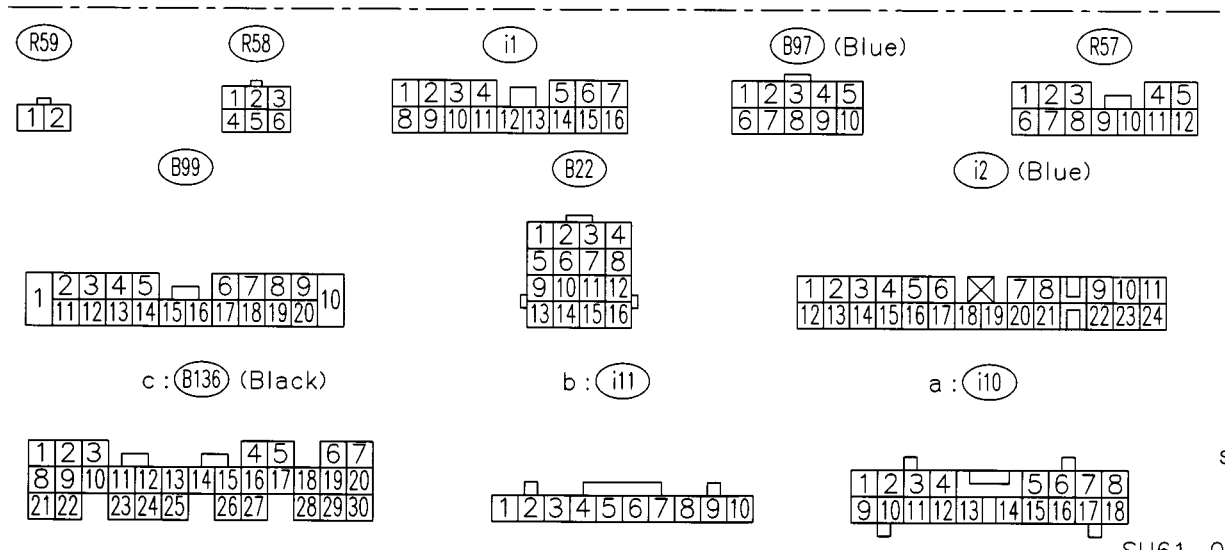
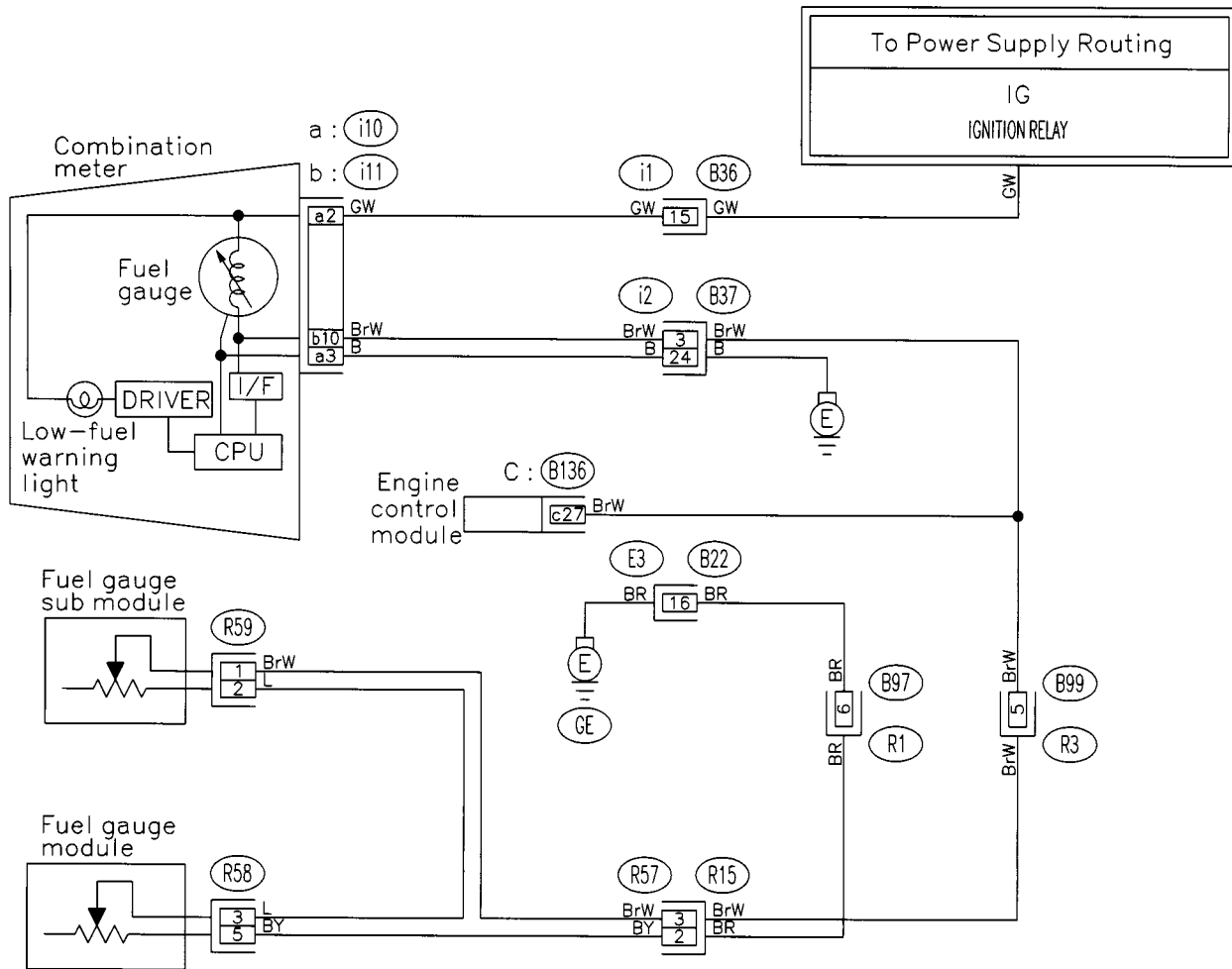

SU61-04

SU61-04

O: HORN AND FRONT ACCESSORY POWER SUPPLY SYSTEM

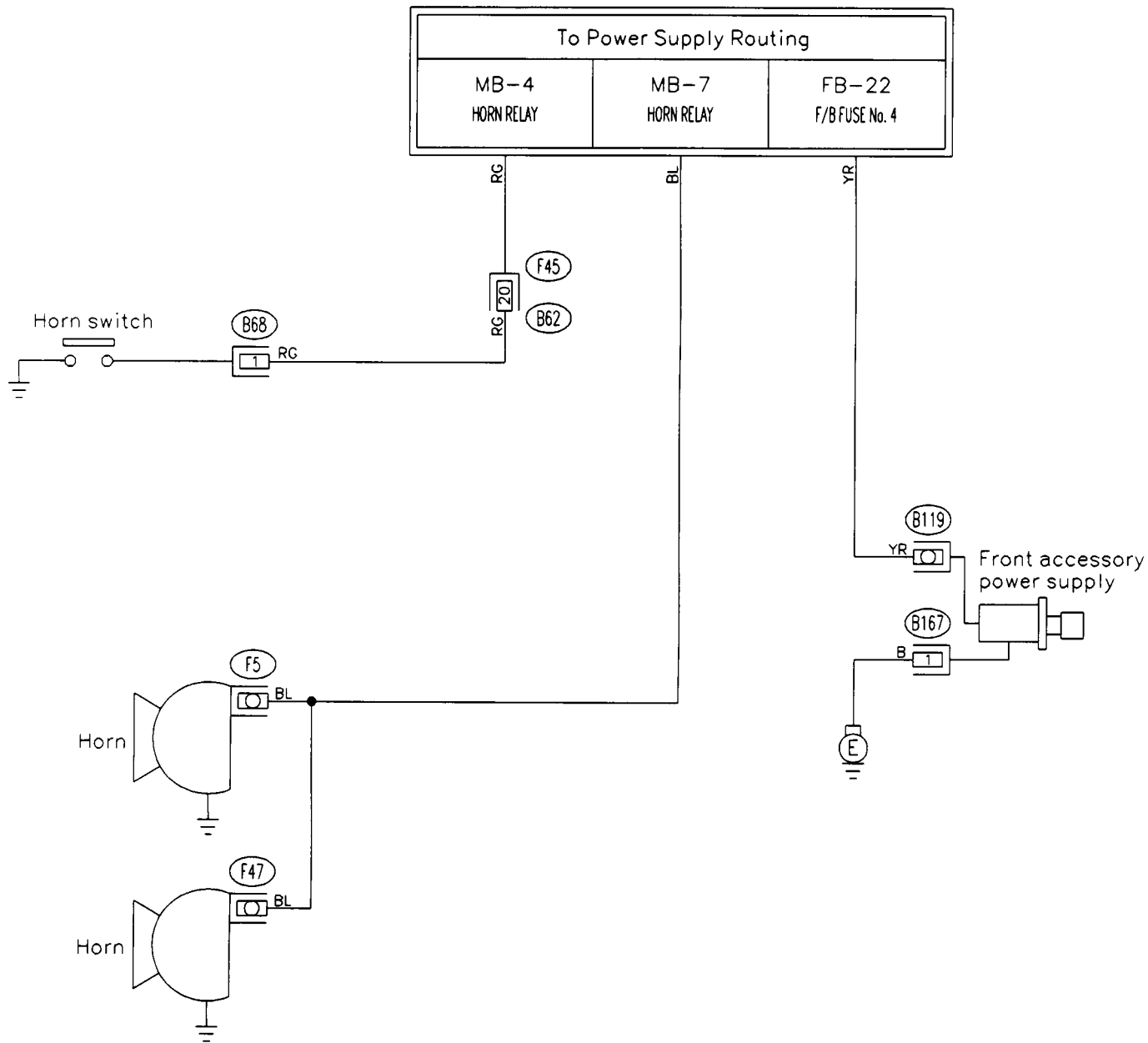

SU74-02

B167

B68 (Black)

B62

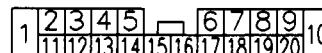

SU74-02

P: KEYLESS ENTRY AND SECURITY SYSTEM

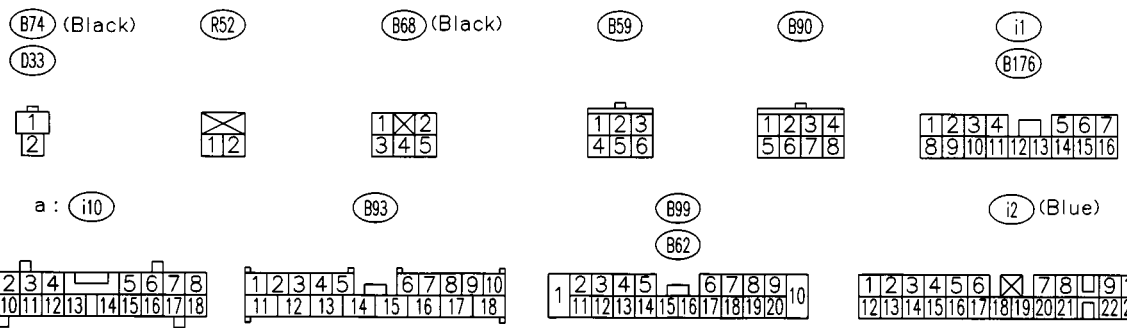
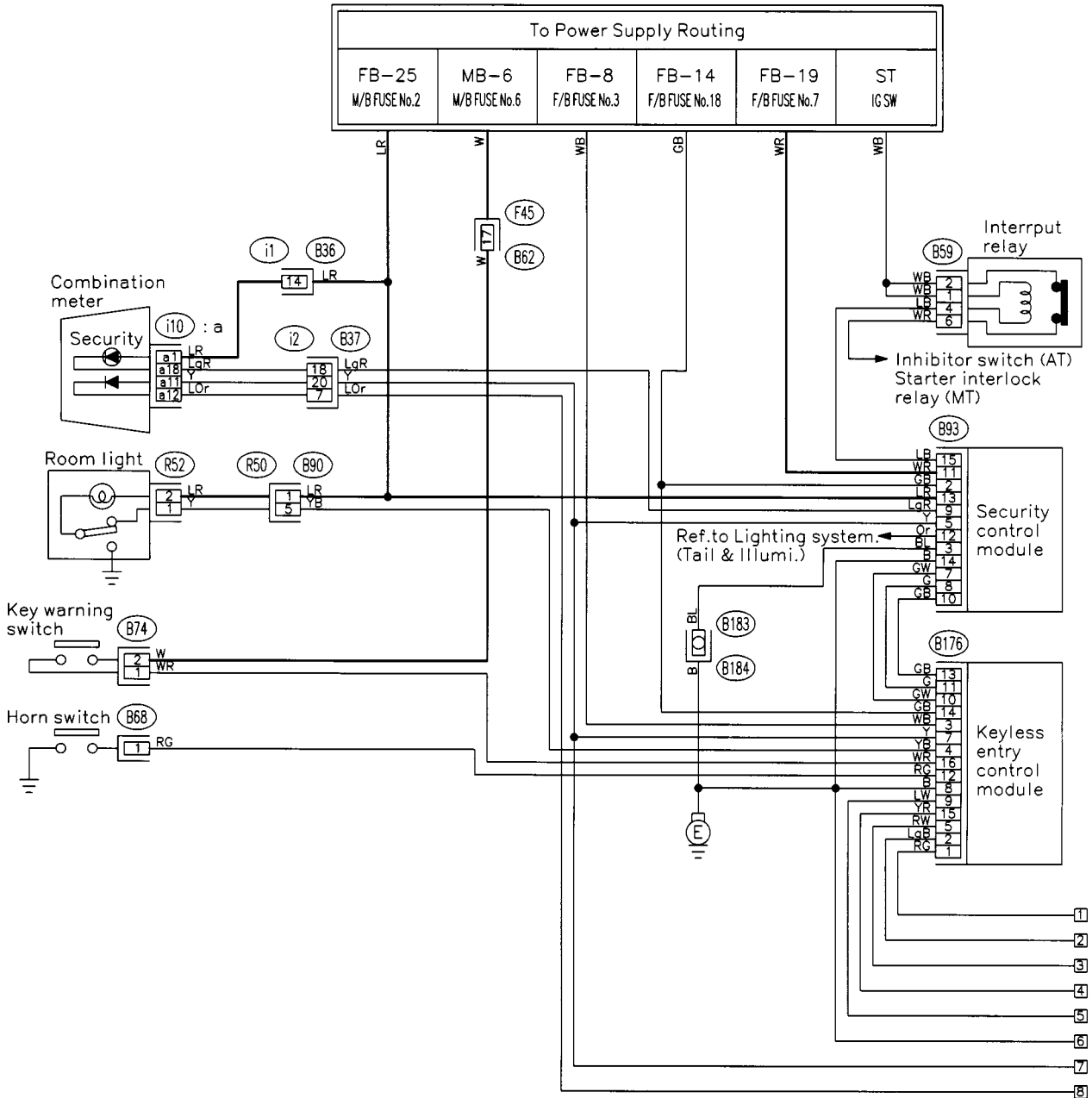

SU77-02A

SU77-02A

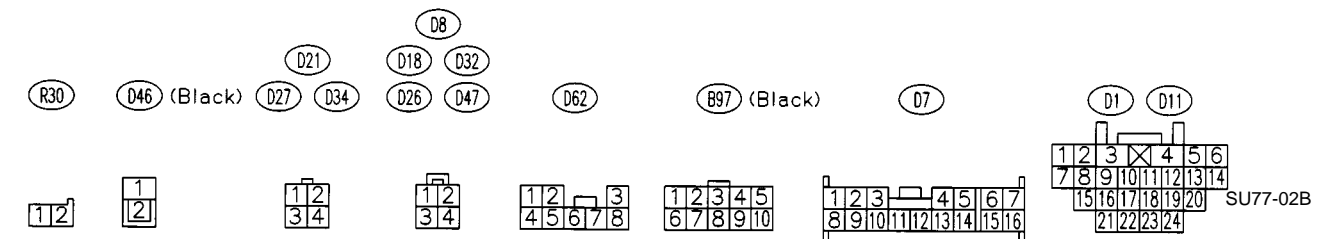
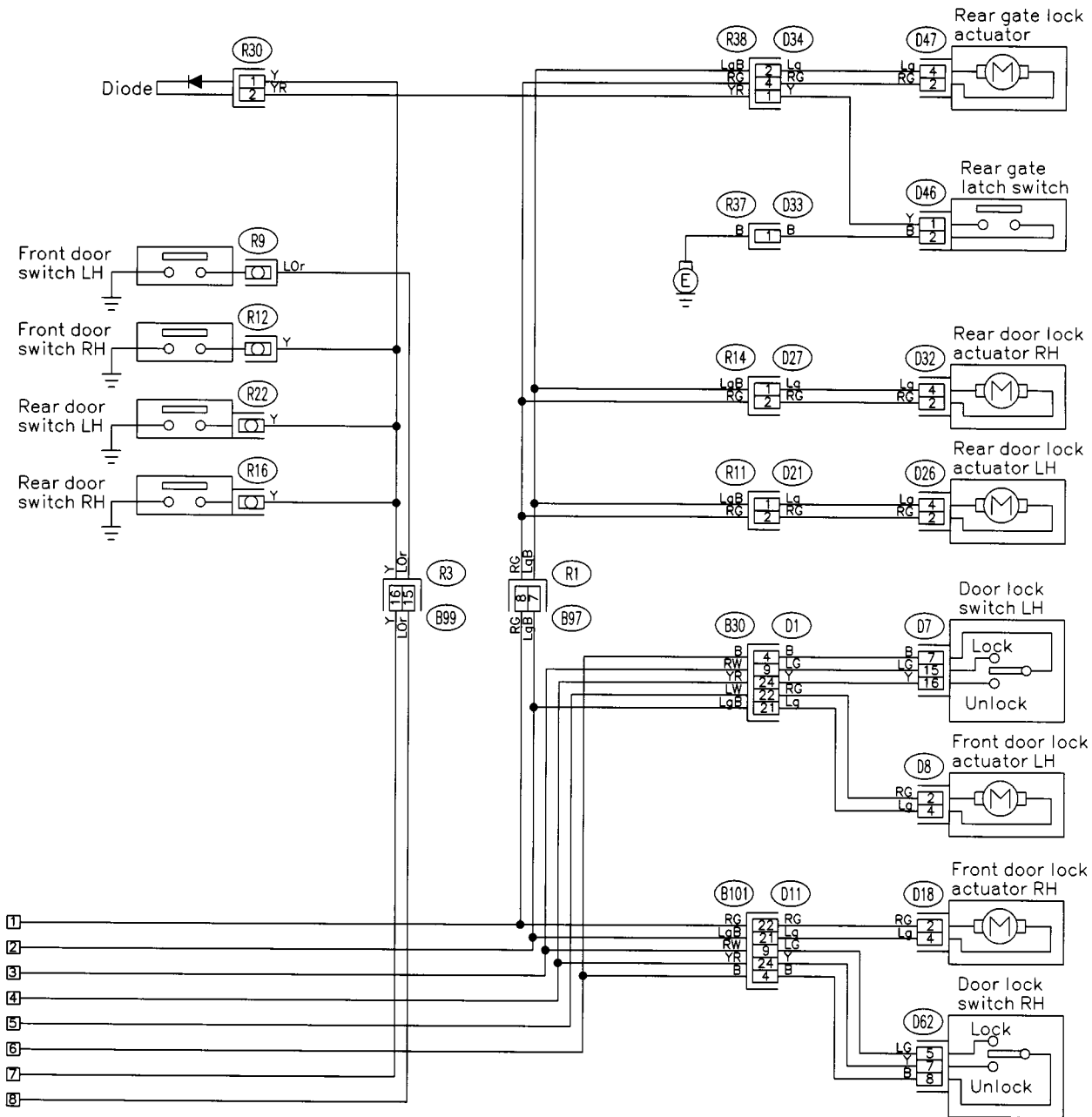

SU77-02B

Q: LIGHTING SYSTEM (BACK-UP LIGHT)

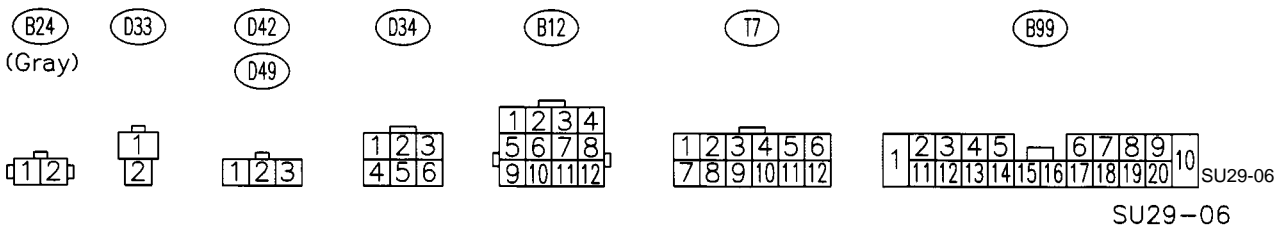
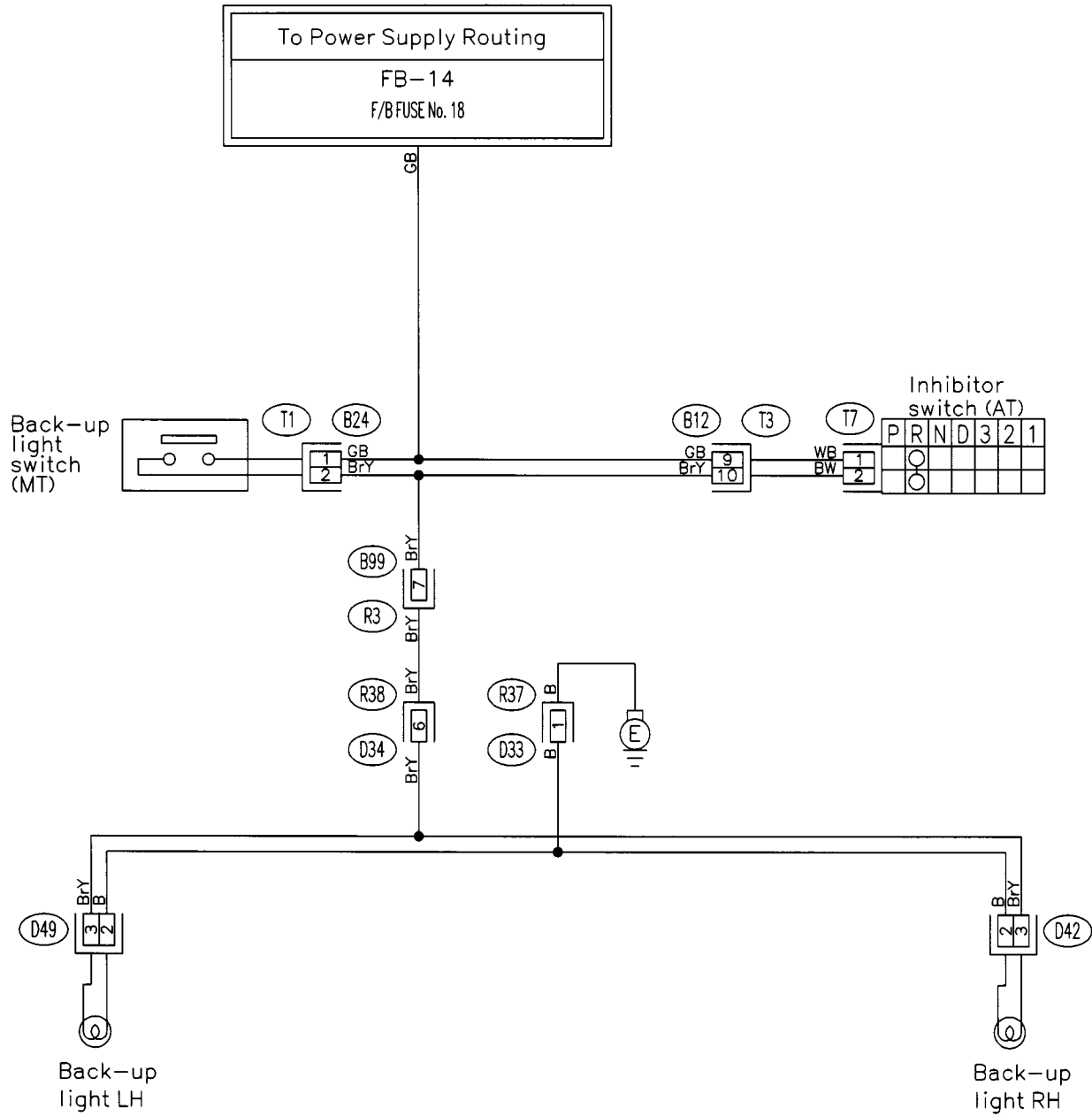

MEMO:

R: LIGHTING SYSTEM (CLEARANCE LIGHT AND ILLUMINATION LIGHT)

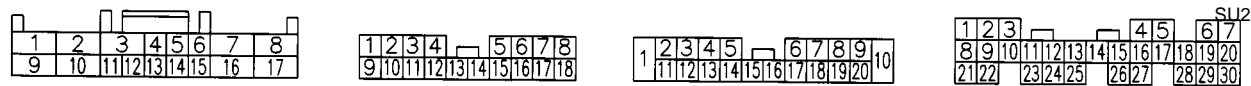
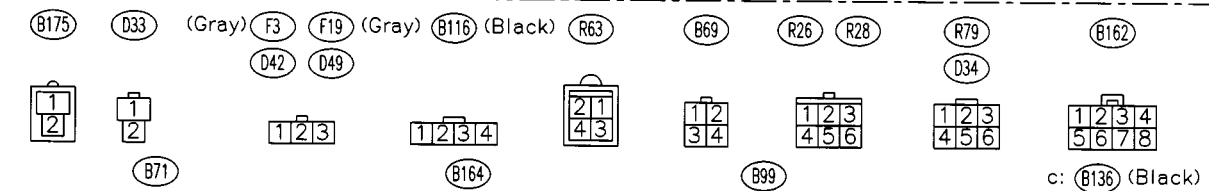
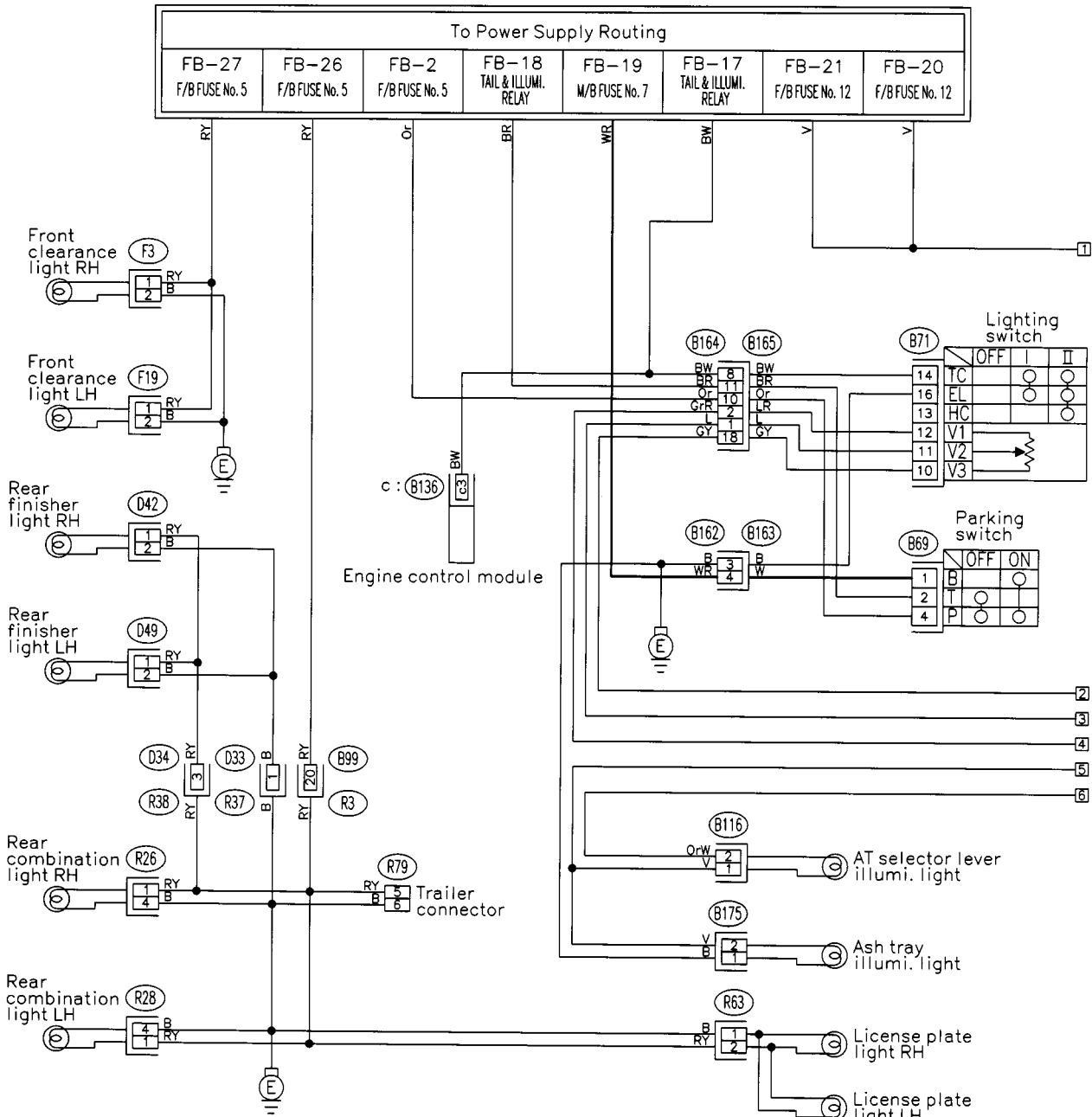

SU21-06A
SU21-06A

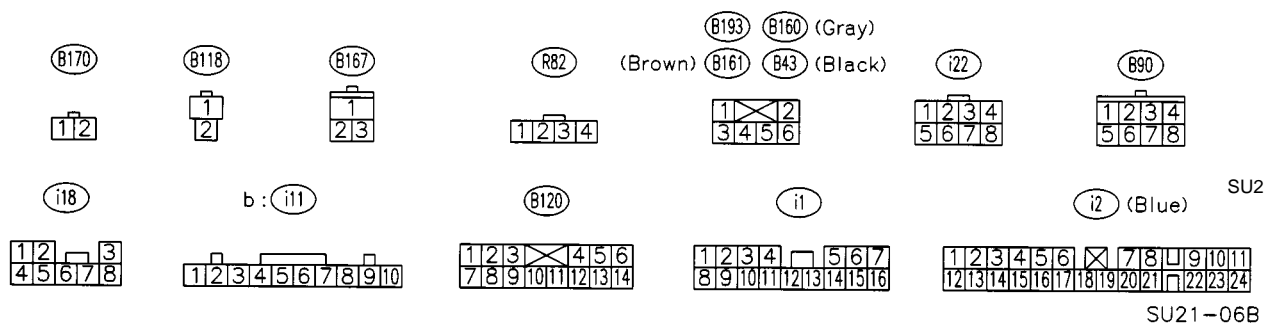
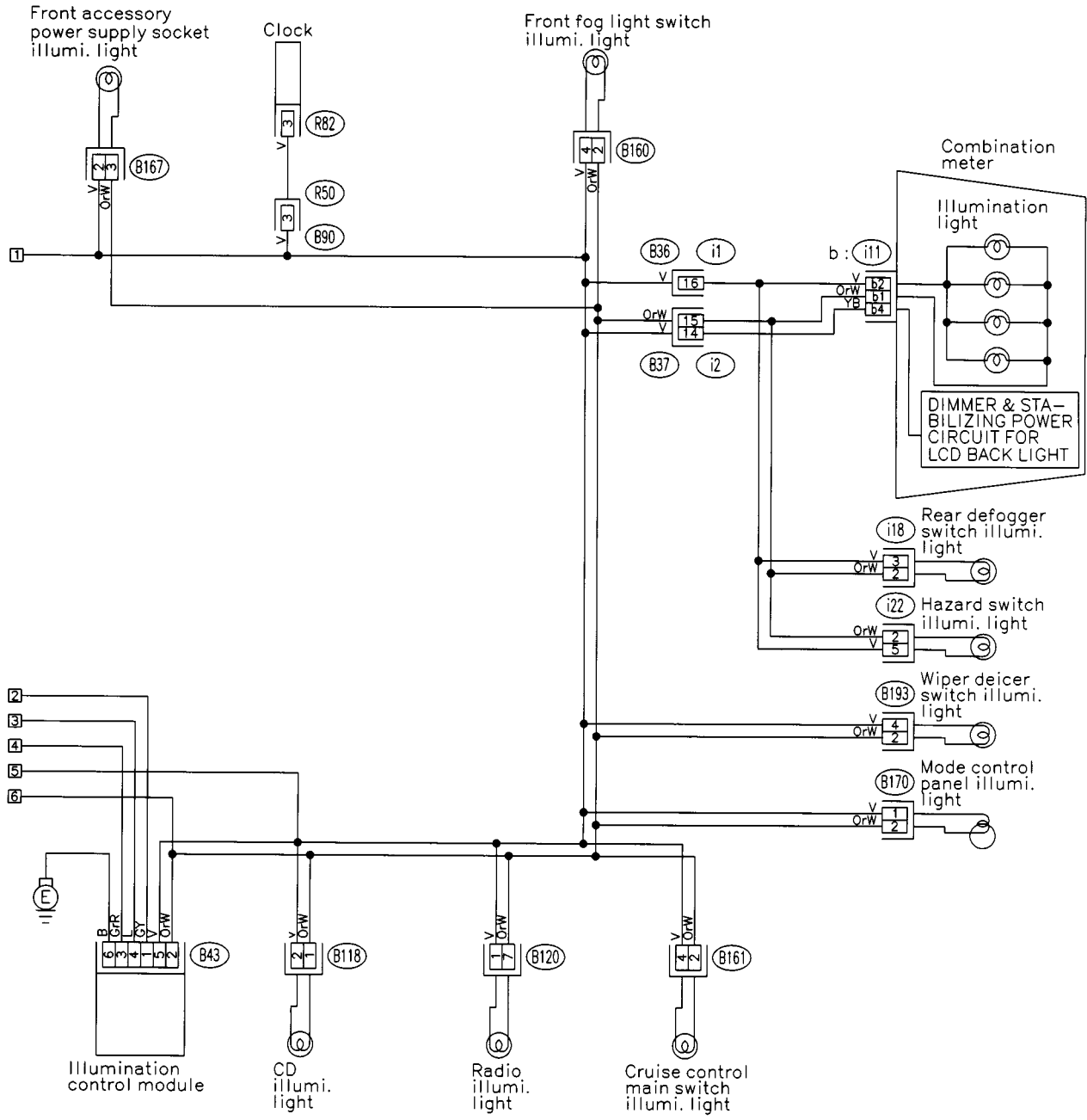

S: LIGHTING SYSTEM (FRONT FOG LIGHT)

1. WITHOUT DRL MODEL

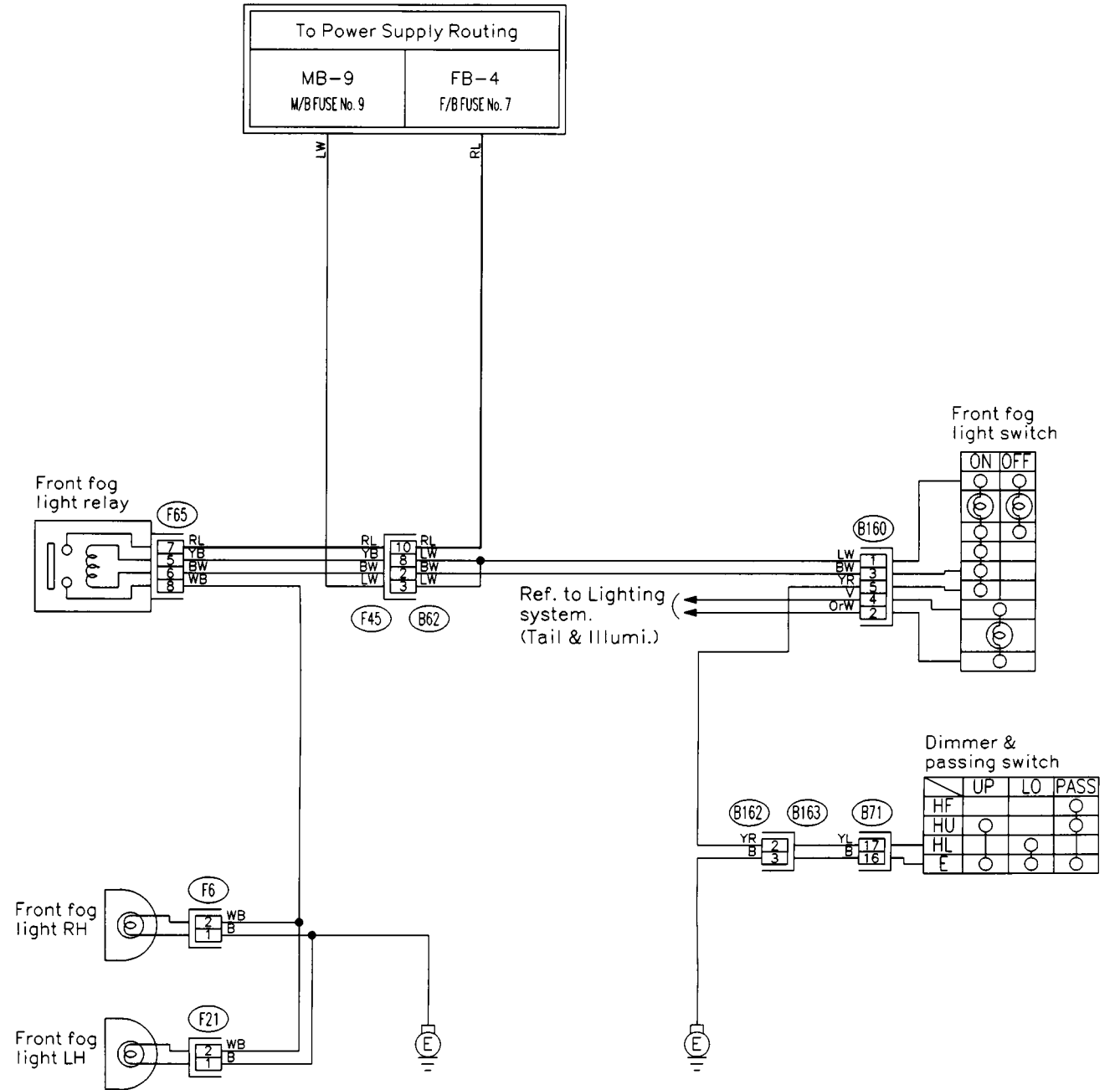

(Black) (F6) (F21) (Black)

(B62)

(B71)

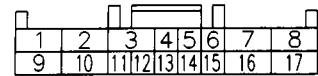
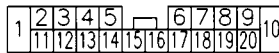

(F27) (F65) (F31) (F28) (F66) (F67)

(B162)

(B160) (Gray)

SU22-02

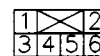
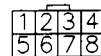
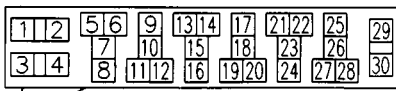

SU22-02

2. WITH DRL MODEL

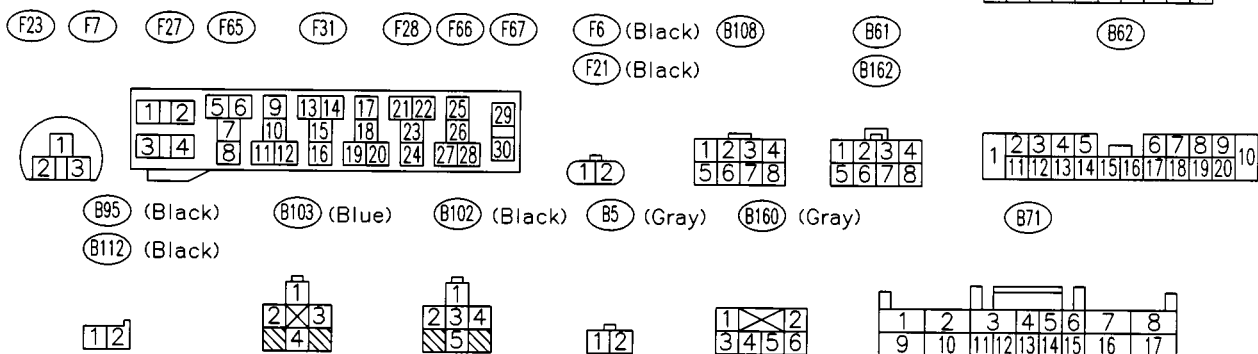
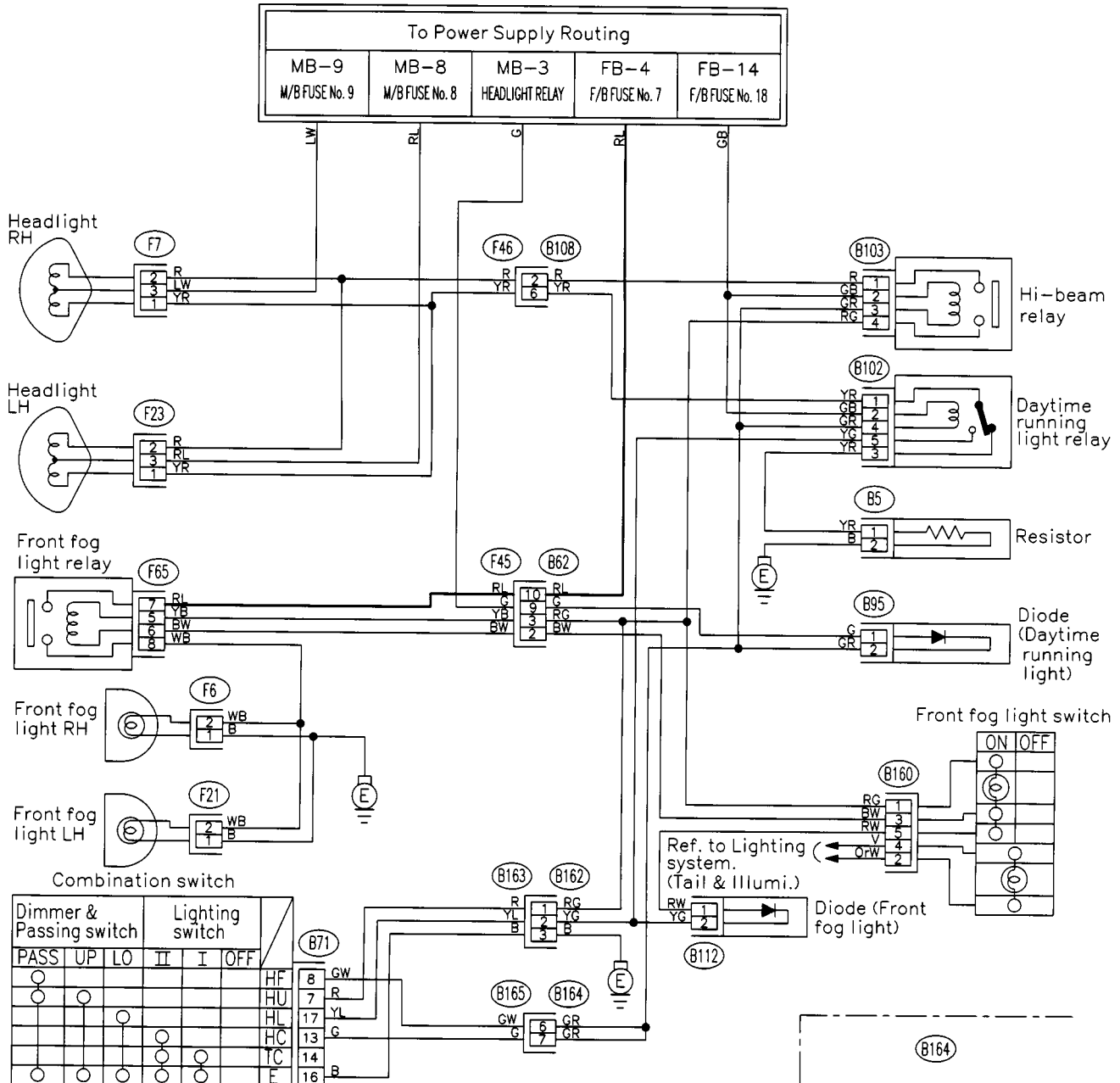

SU22-04

SU22-04

T: LIGHTING SYSTEM (HEADLIGHT)

1. WITHOUT DRL MODEL

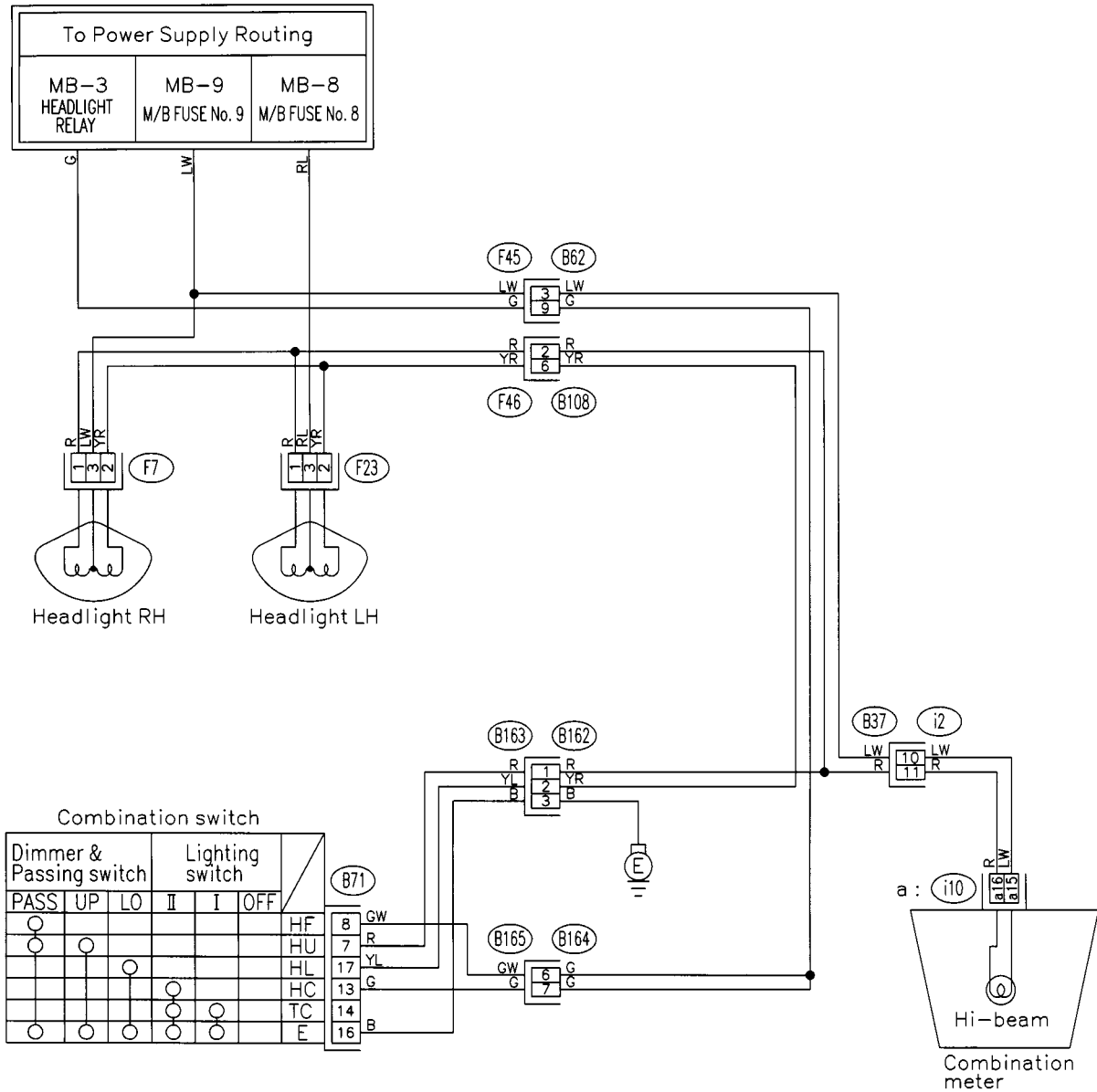

Combination switch

Dimmer & Passing switch			Lighting switch			
PASS	UP	LO	II	I	OFF	
<input type="checkbox"/>	<input type="checkbox"/>	<input type="checkbox"/>	<input type="checkbox"/>	<input type="checkbox"/>	<input type="checkbox"/>	HF
<input type="checkbox"/>	<input type="checkbox"/>	<input type="checkbox"/>	<input type="checkbox"/>	<input type="checkbox"/>	<input type="checkbox"/>	HU
<input type="checkbox"/>	<input type="checkbox"/>	<input type="checkbox"/>	<input type="checkbox"/>	<input type="checkbox"/>	<input type="checkbox"/>	HL
<input type="checkbox"/>	<input type="checkbox"/>	<input type="checkbox"/>	<input type="checkbox"/>	<input type="checkbox"/>	<input type="checkbox"/>	HC
<input type="checkbox"/>	<input type="checkbox"/>	<input type="checkbox"/>	<input type="checkbox"/>	<input type="checkbox"/>	<input type="checkbox"/>	TC
<input type="checkbox"/>	<input type="checkbox"/>	<input type="checkbox"/>	<input type="checkbox"/>	<input type="checkbox"/>	<input type="checkbox"/>	E

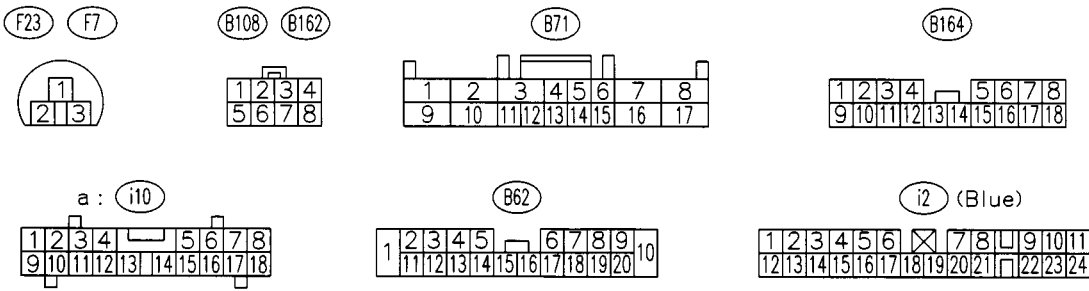

SU20-06

SU20-06

MEMO:

2. WITH DRL MODEL

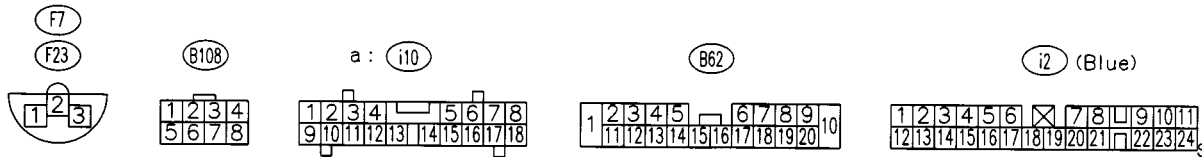
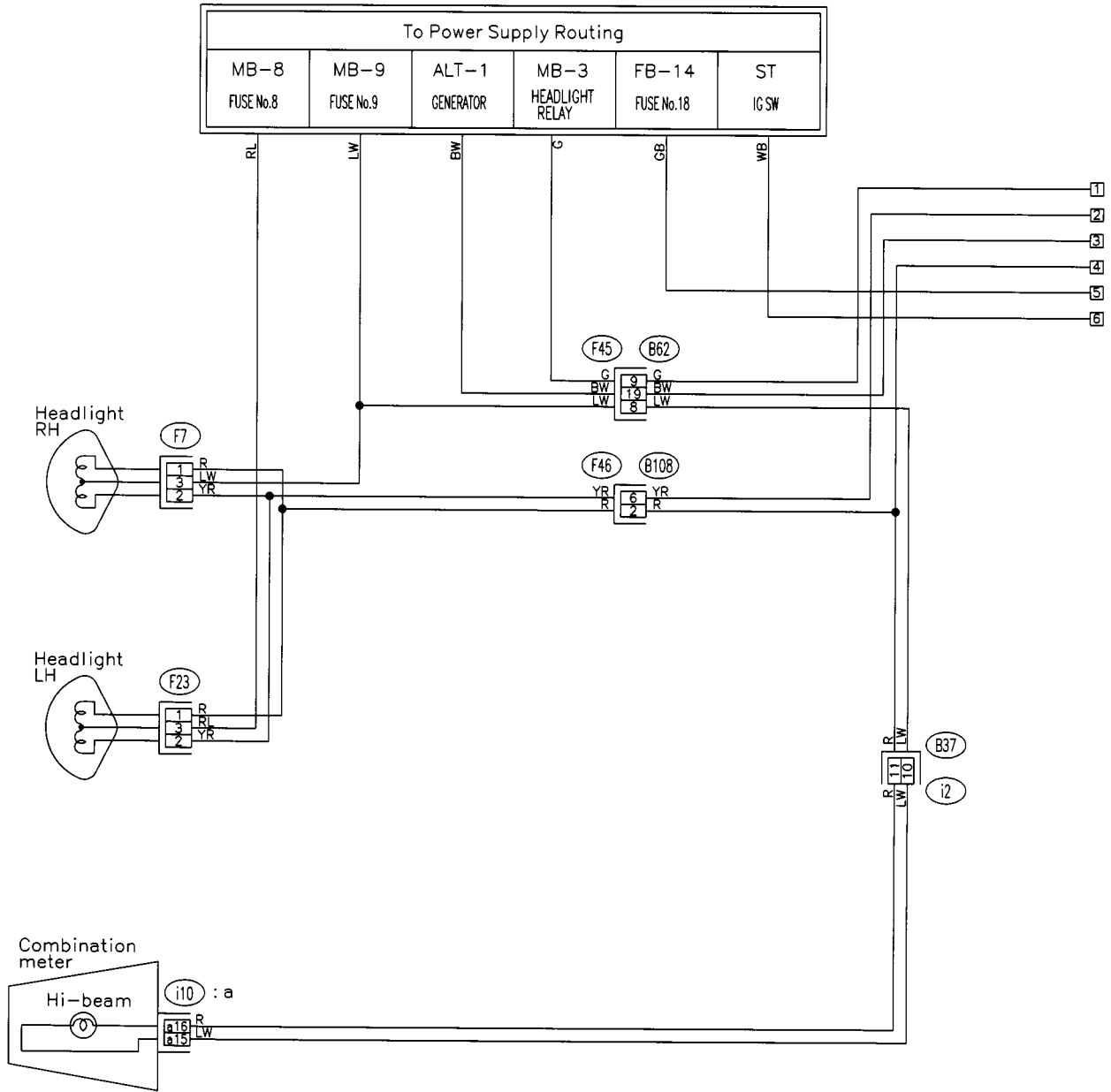

SU18-02A

SU18-02A

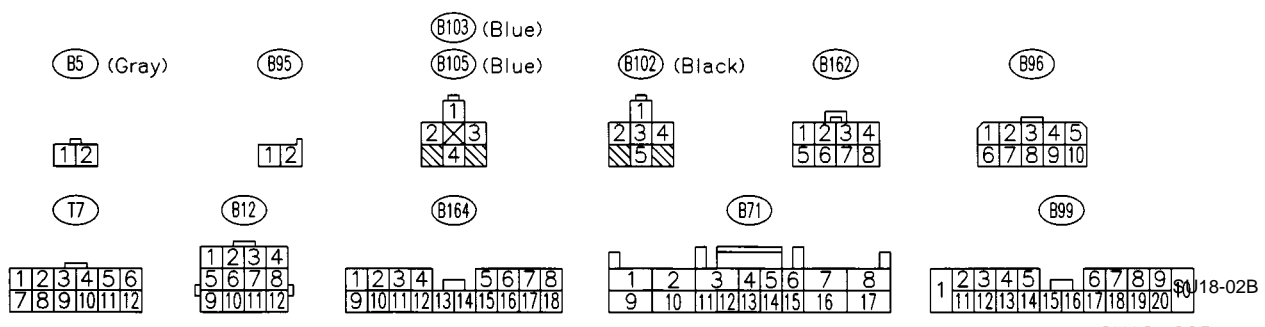
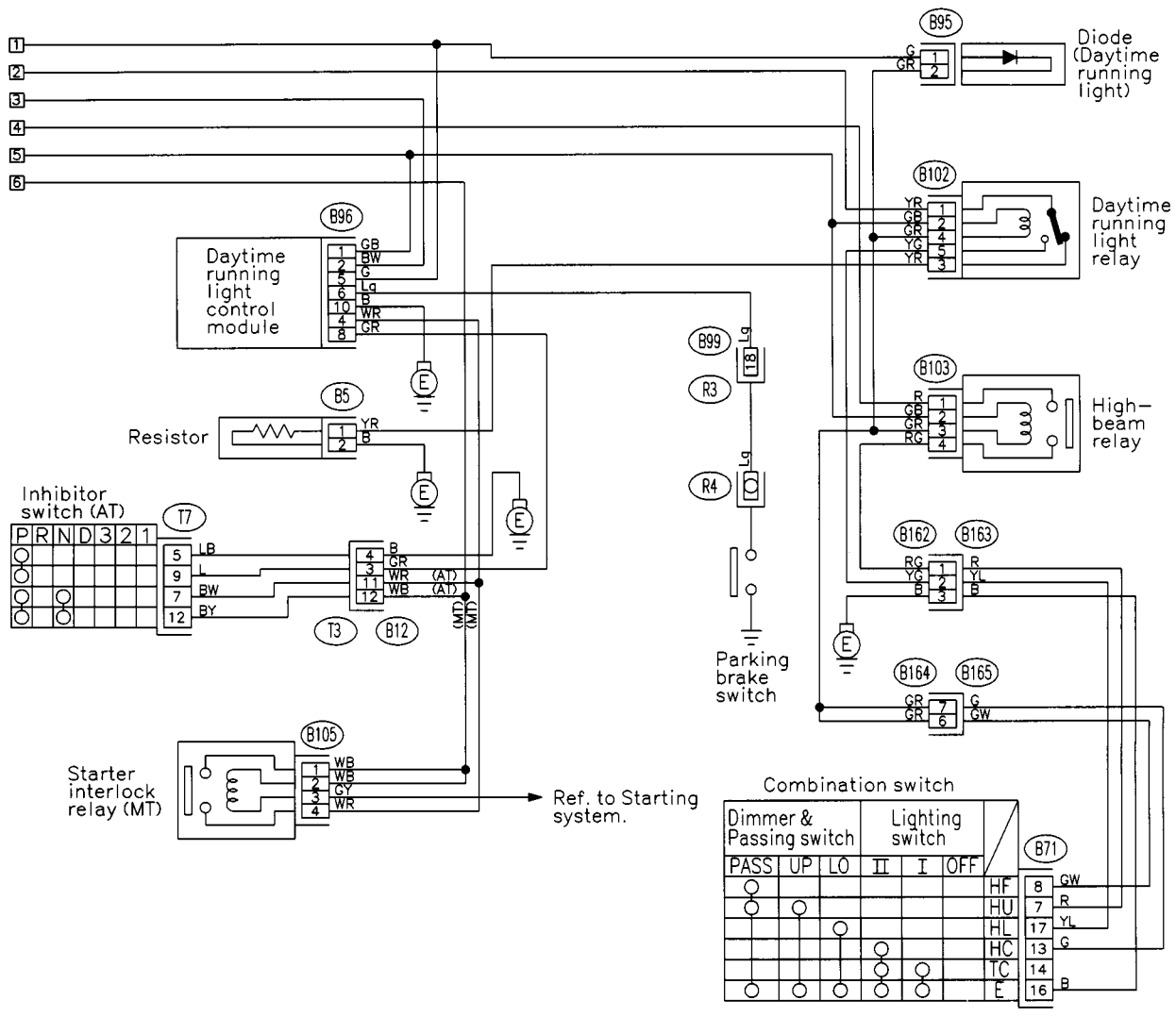

SU18-02B

W: LIGHTING SYSTEM (TURN SIGNAL LIGHT AND HAZARD LIGHT)

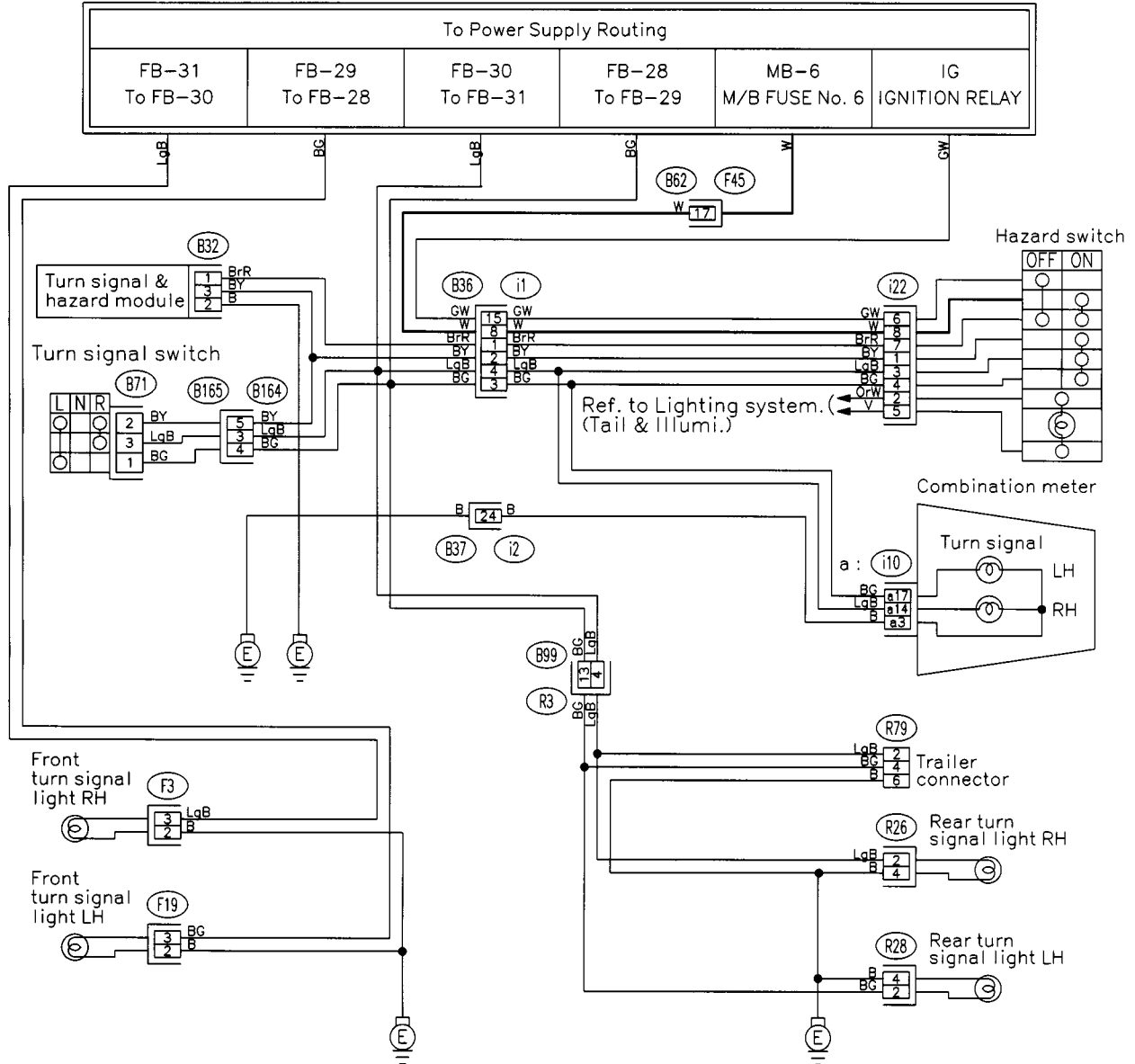

(Gray) (Gray)

F3 F19



B32 (Black)



R79



R26 R28



i22

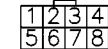

i1

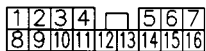

B71



B164

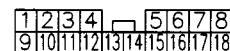

a : i10

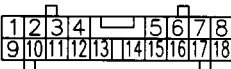

B62

B99

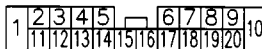

i2 (Blue)

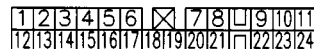

SU26-04

SU26-04

X: MULTIPLE POWER SOCKET SYSTEM (OPTION)

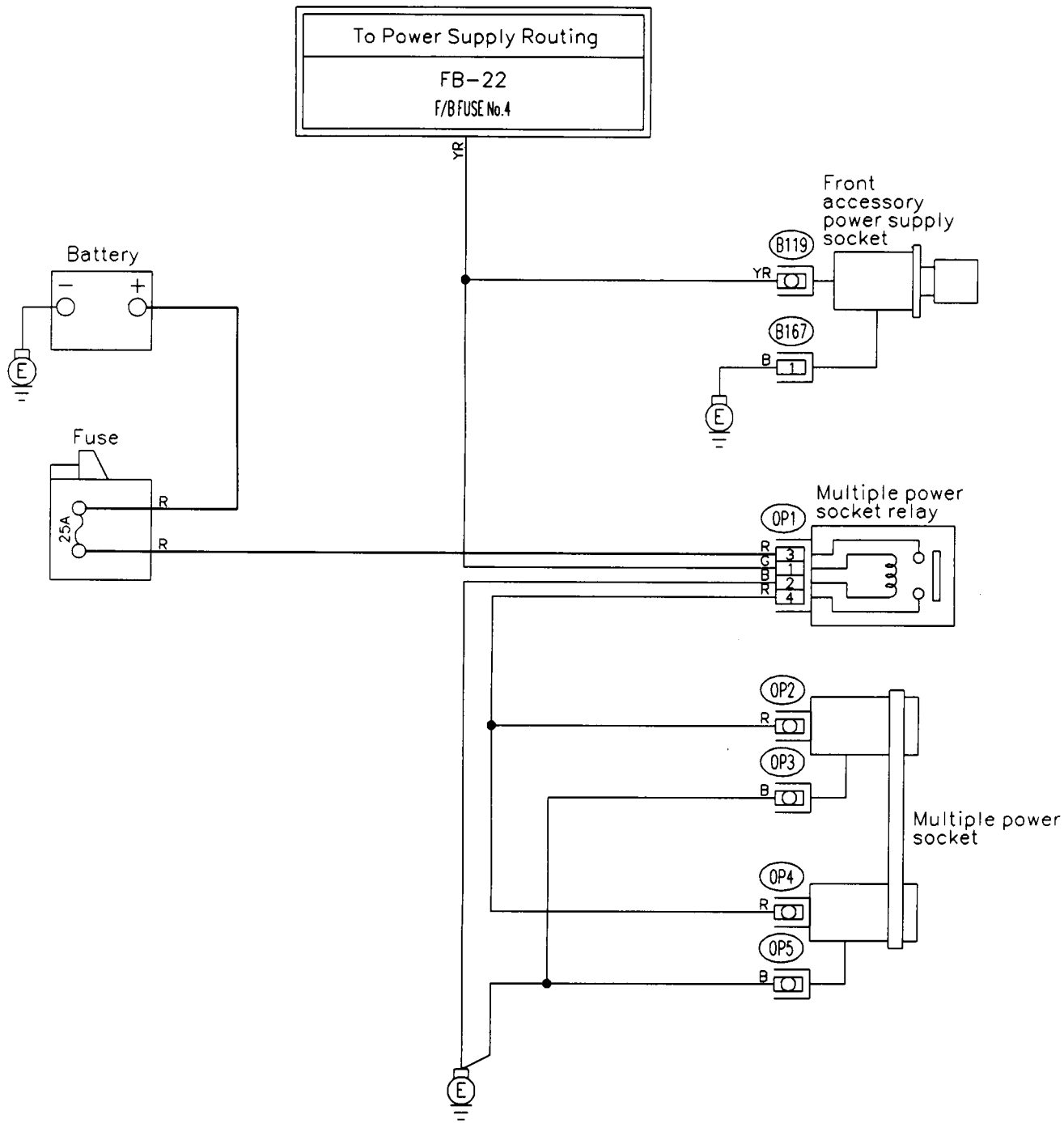

(B167)

(OP1) (Blue)



SU92-01

SU92-01

Y: OIL PRESSURE AND TEMPERATURE GAUGE SYSTEM

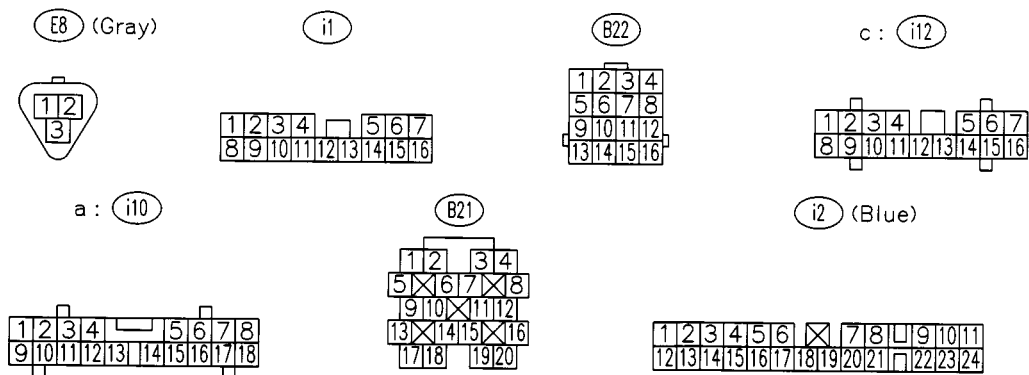
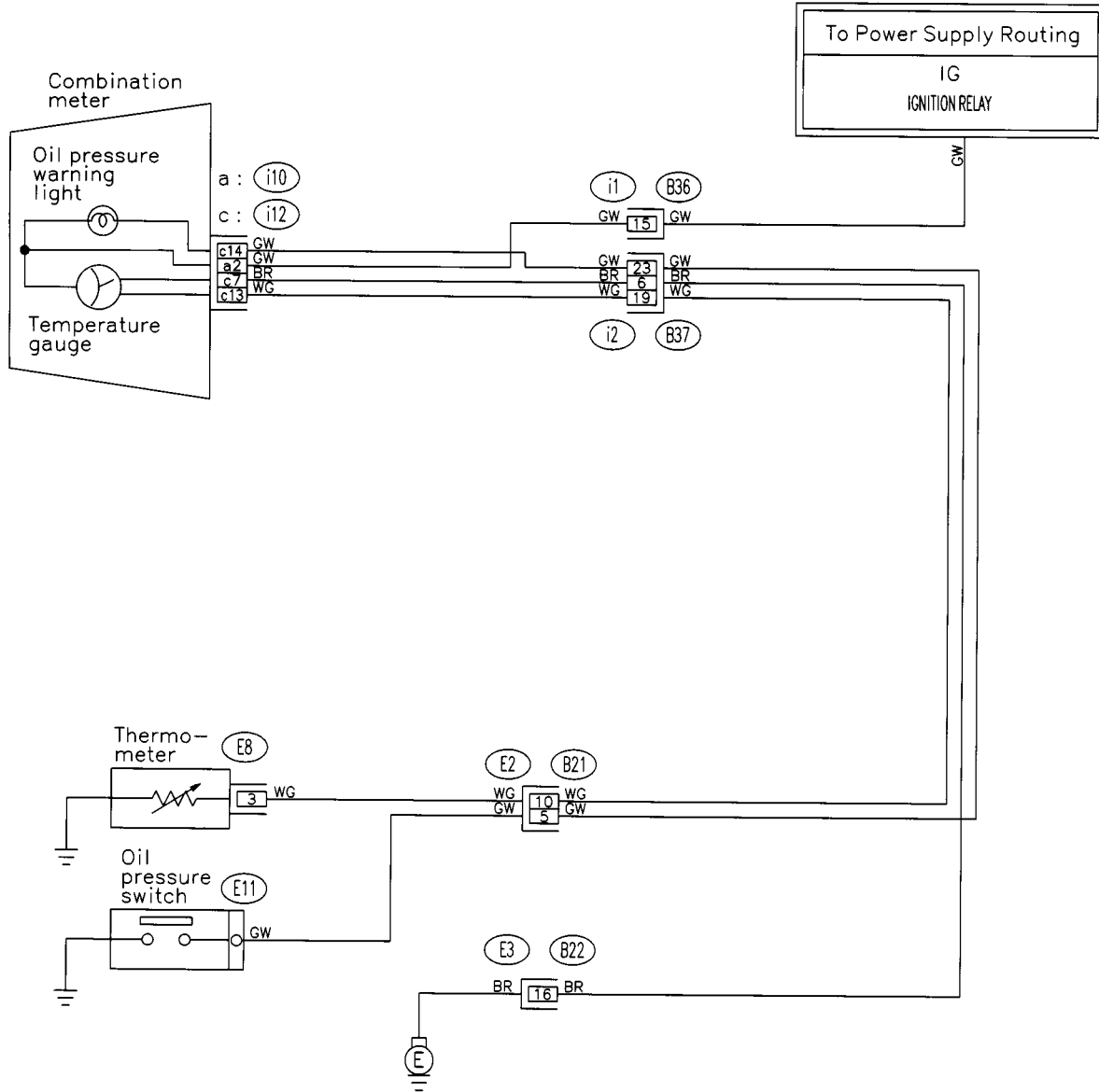

SU66-04

SU66-04

Z: OUTSIDE TEMPERATURE DISPLAY SYSTEM

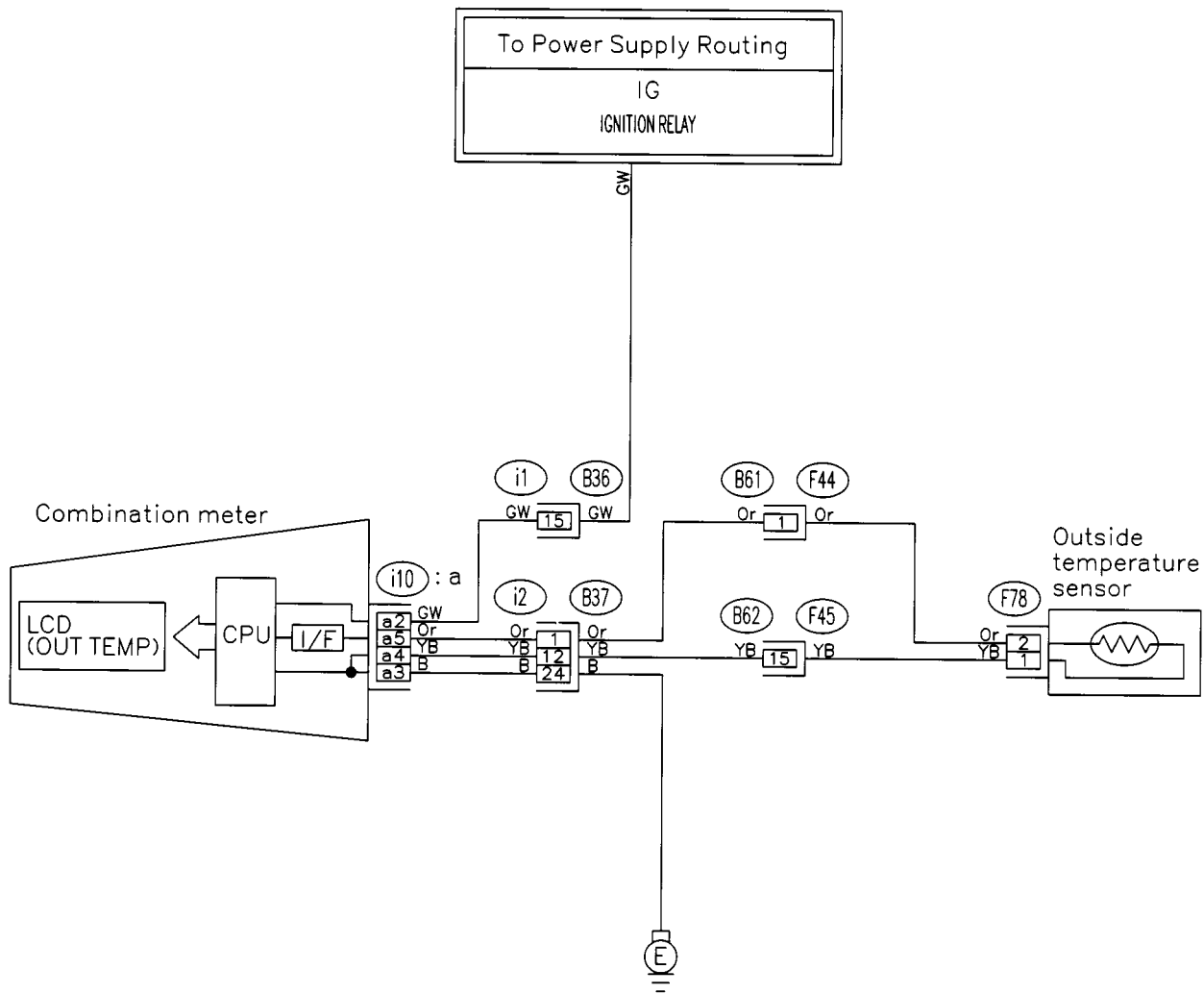

(F78) (Black)

(B61)

(i1)

a : (i10)

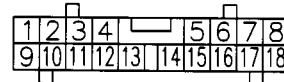
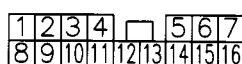
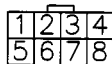

(B62)

(i2) (Blue)

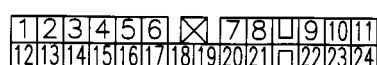
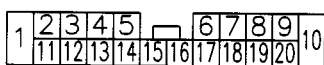

SU96-01

SU96-01

AA: PARKING BRAKE AND BRAKE FLUID LEVEL WARNING SYSTEM

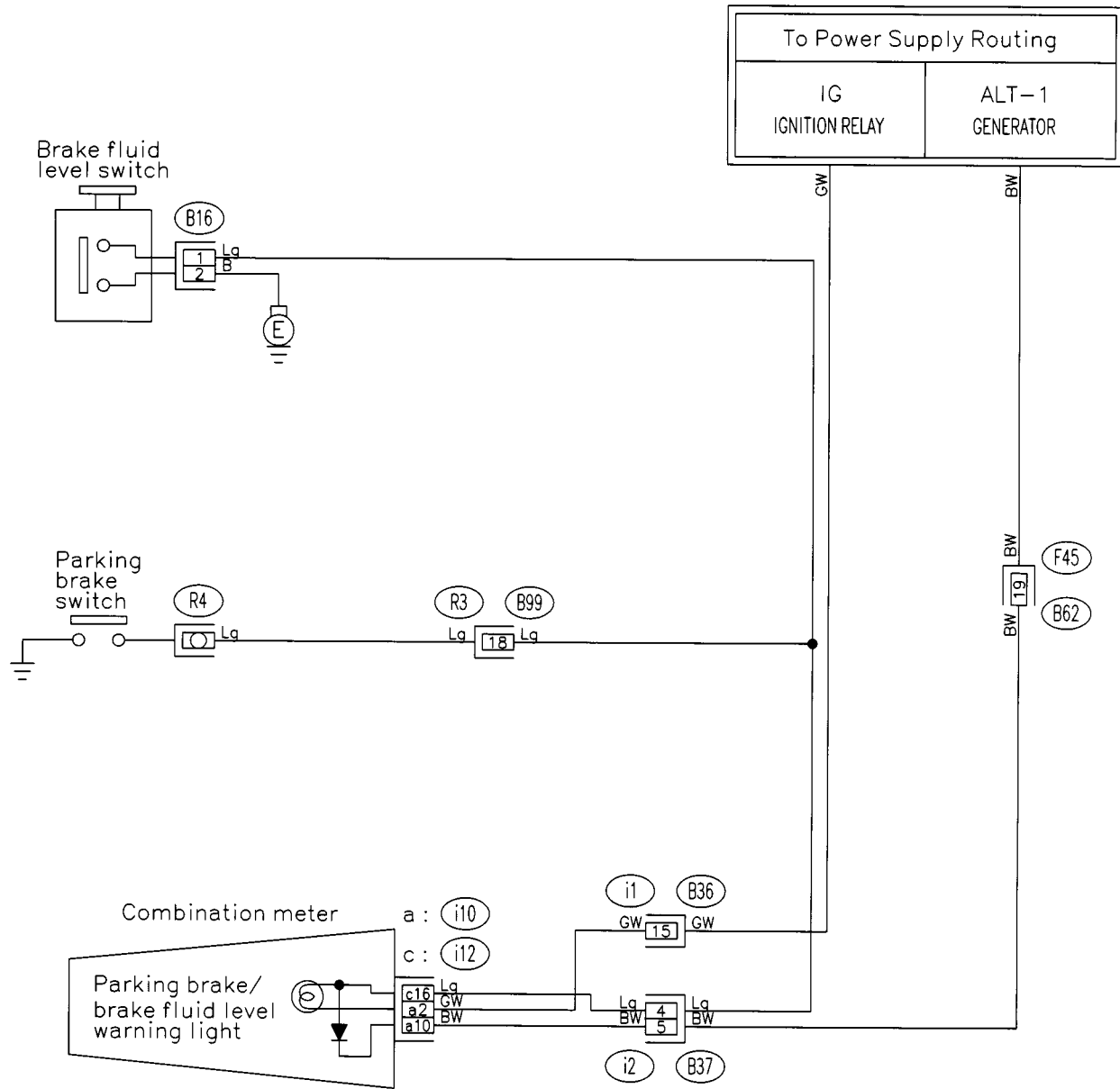

B16 (Gray)



i1

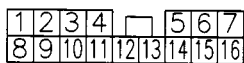

c : i12

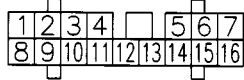

a : i10

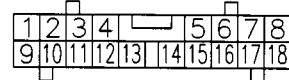

B62

B99

i2 (Blue)

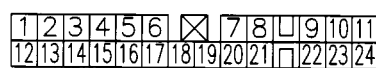
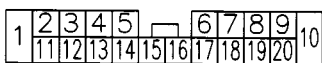

SU60-03

SU60-03

MEMO:

AB: POWER WINDOW SYSTEM

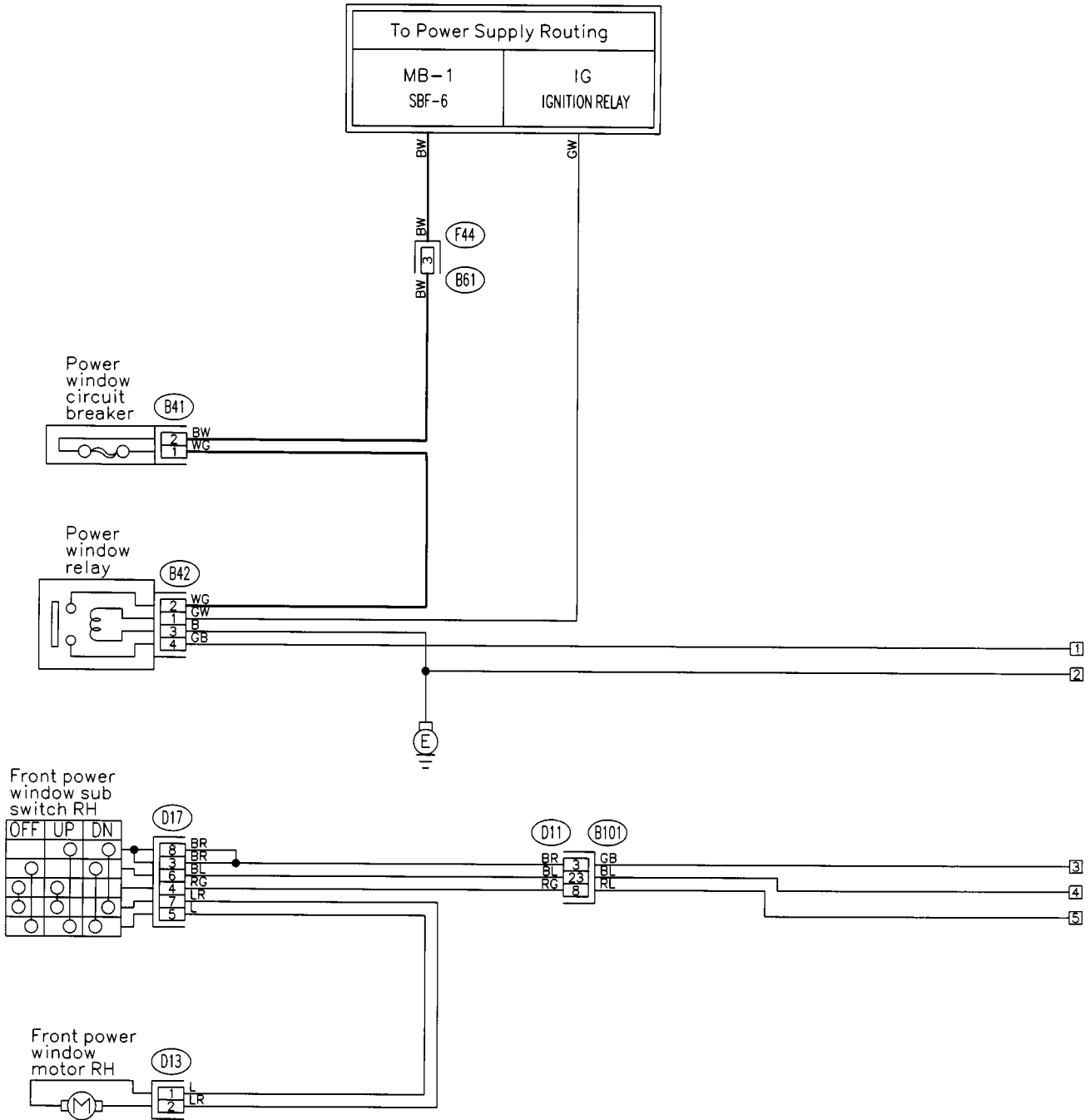

(Blue) (B41)
(Blue) (D3) (D13) (Blue)
(Blue) (D30) (D24) (Blue)

(B42) (Blue)

(B61)

(D11)

SU70-03A

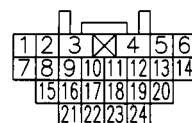

SU70-03A

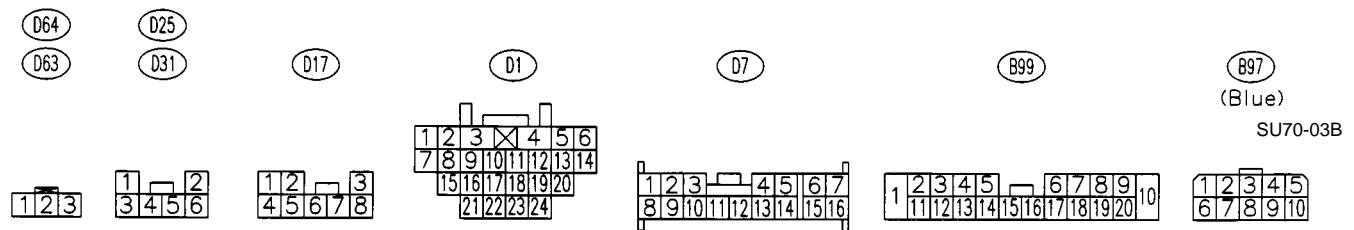
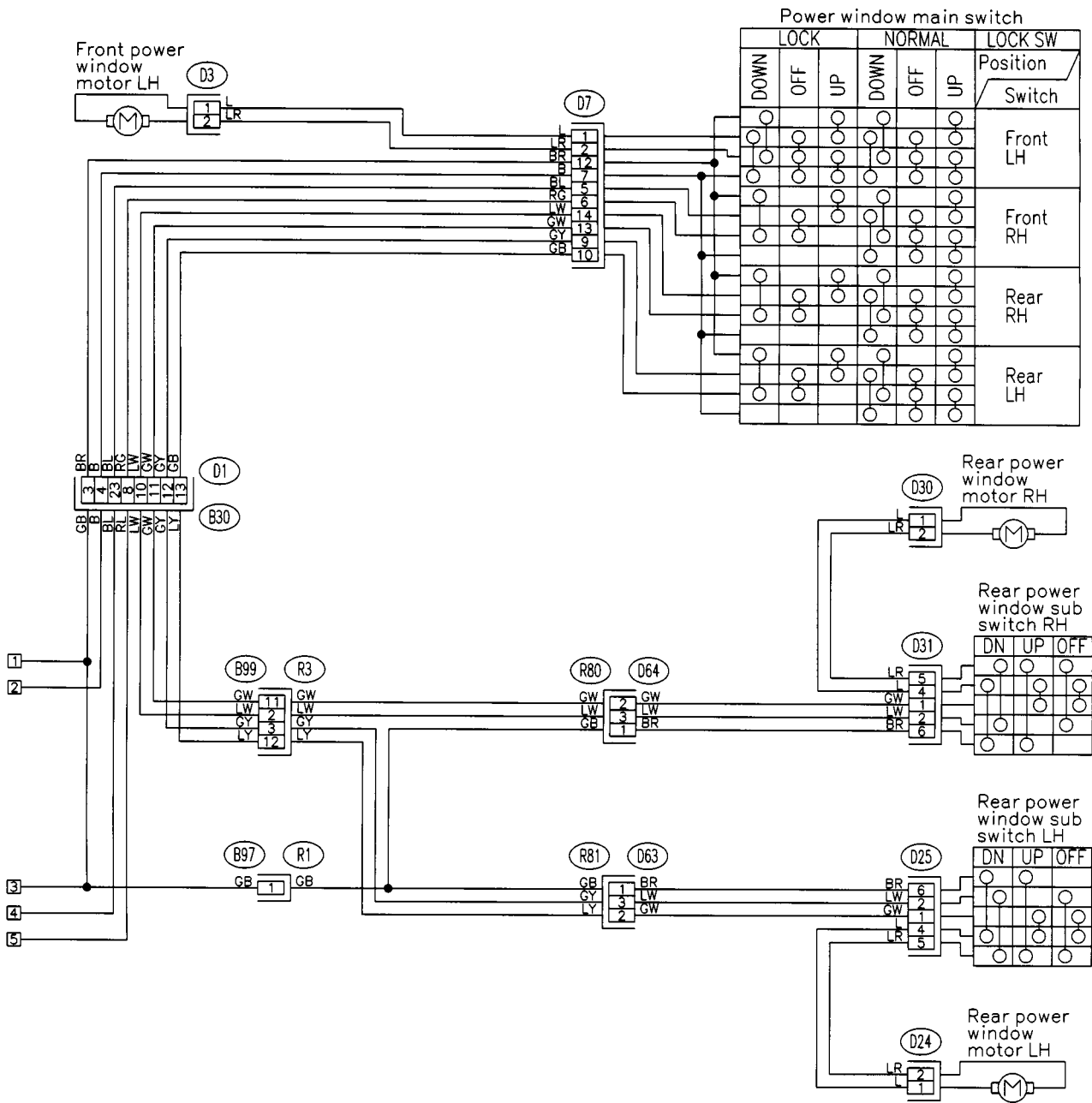

SU70-03B

AC: RADIATOR FAN SYSTEM

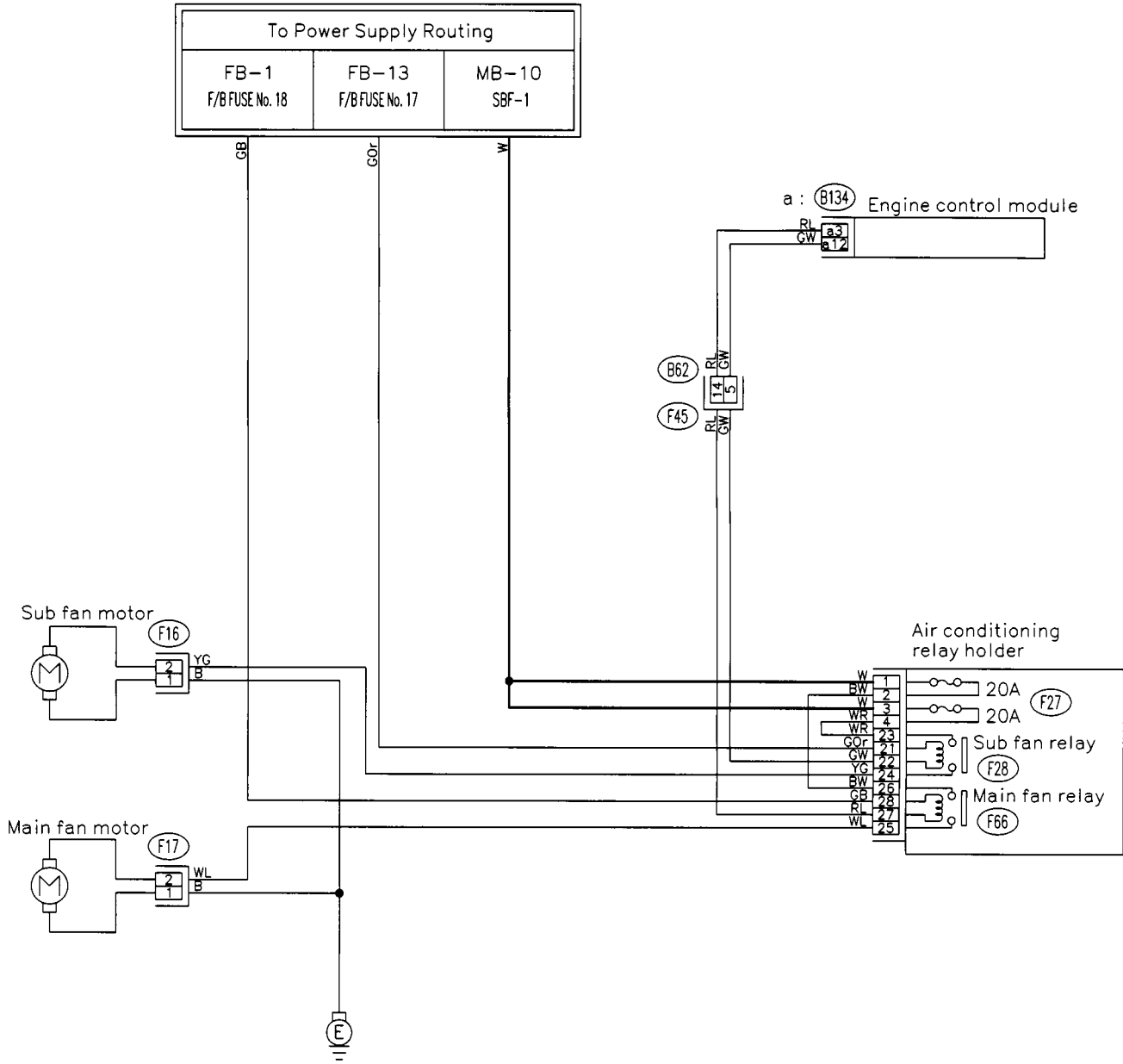

F16 (Black)

F17 (Black)



B62

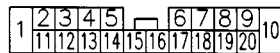

F27 F65 F31 F28 F66 F67

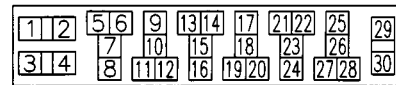

a : B134 (Black)

SU14-03

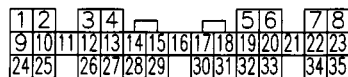

SU14-03

AD: REAR ACCESSORY POWER SUPPLY SYSTEM

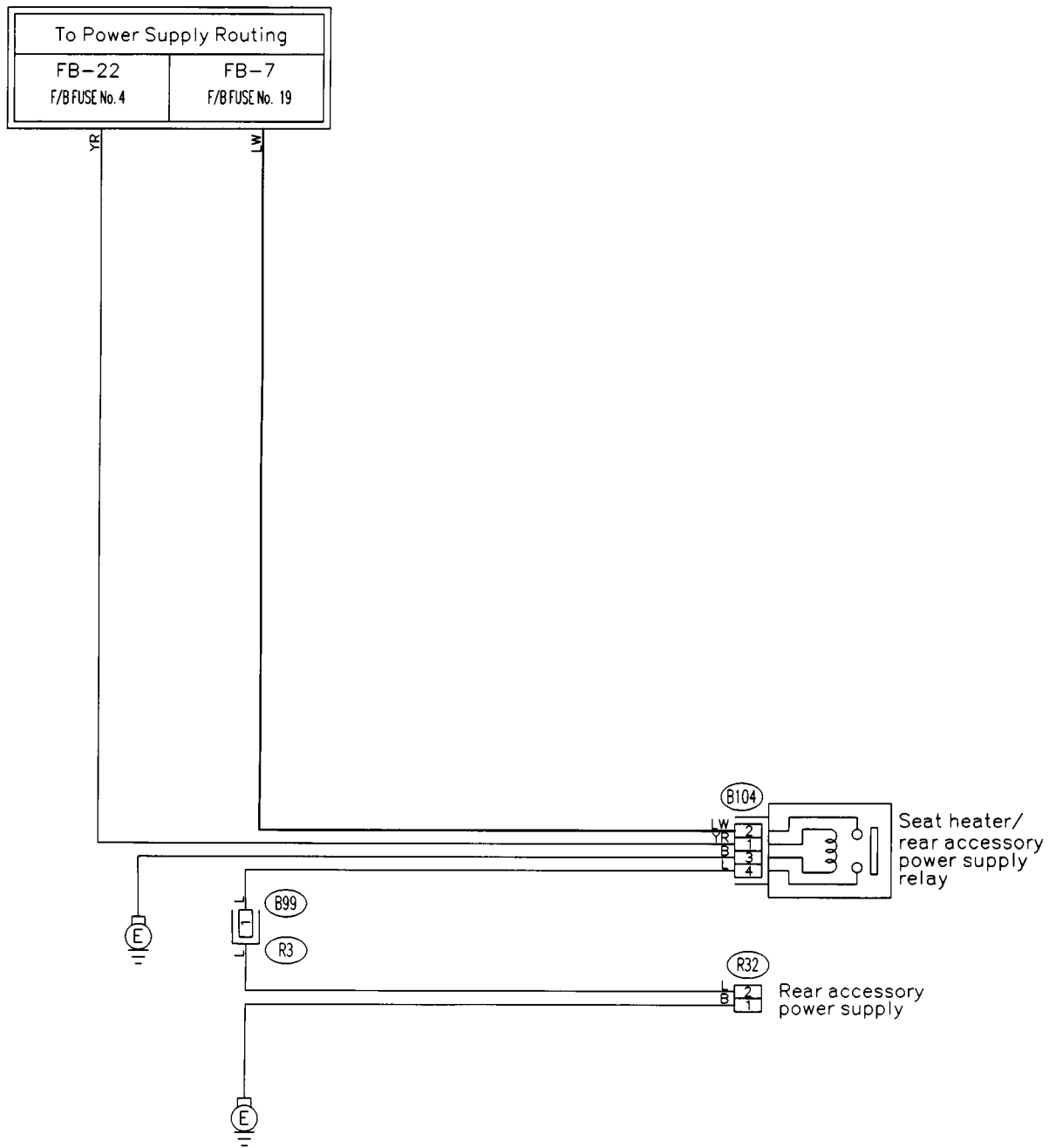

R32

B99

B104

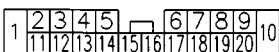

SU90-02

SU90-02

AE: REAR WINDOW DEFOGGER SYSTEM

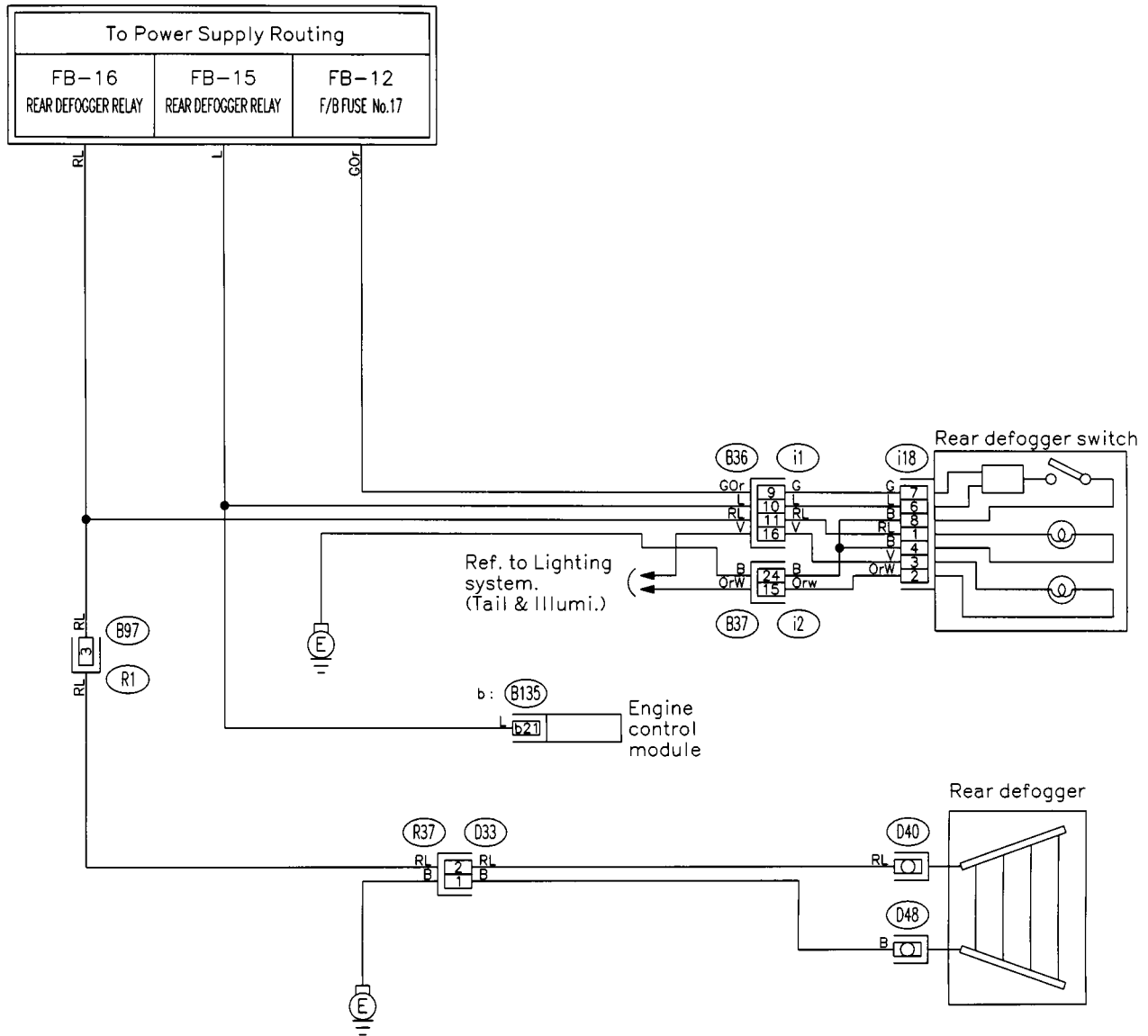

i18 i1 i2 (Blue) B97 (Blue) D33

1	2	3	
4	5	6	7

1	2	3	4		5	6	7
8	9	10	11	12	13	14	15

1	2	3	4	5	6	⊗	7	8	□	9	10	11	
12	13	14	15	16	17	18	19	20	21	□	22	23	24

1	2	3	4	5
6	7	8	9	10

1
2

b: (B135) (Black)

SU52-03

1	2	3				4	5	6	7
8	9	10	11	12	13	14	15	16	17
18	19								
20	21	22	23	24	25	26	27	28	

SU52-03

AG: SEAT BELT WARNING AND KEY WARNING SYSTEM

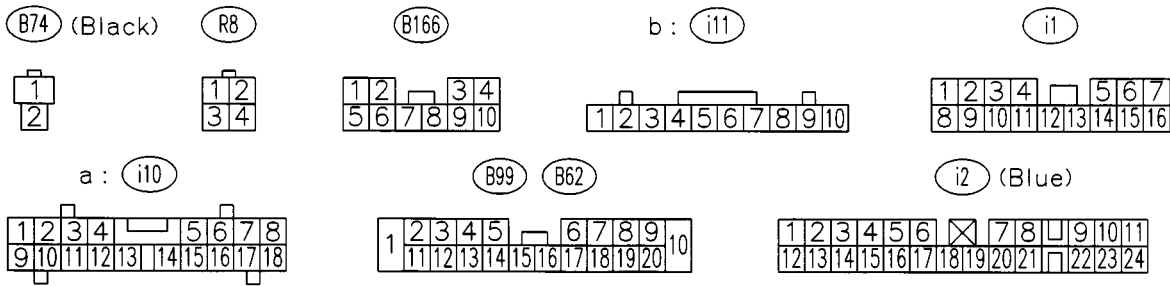
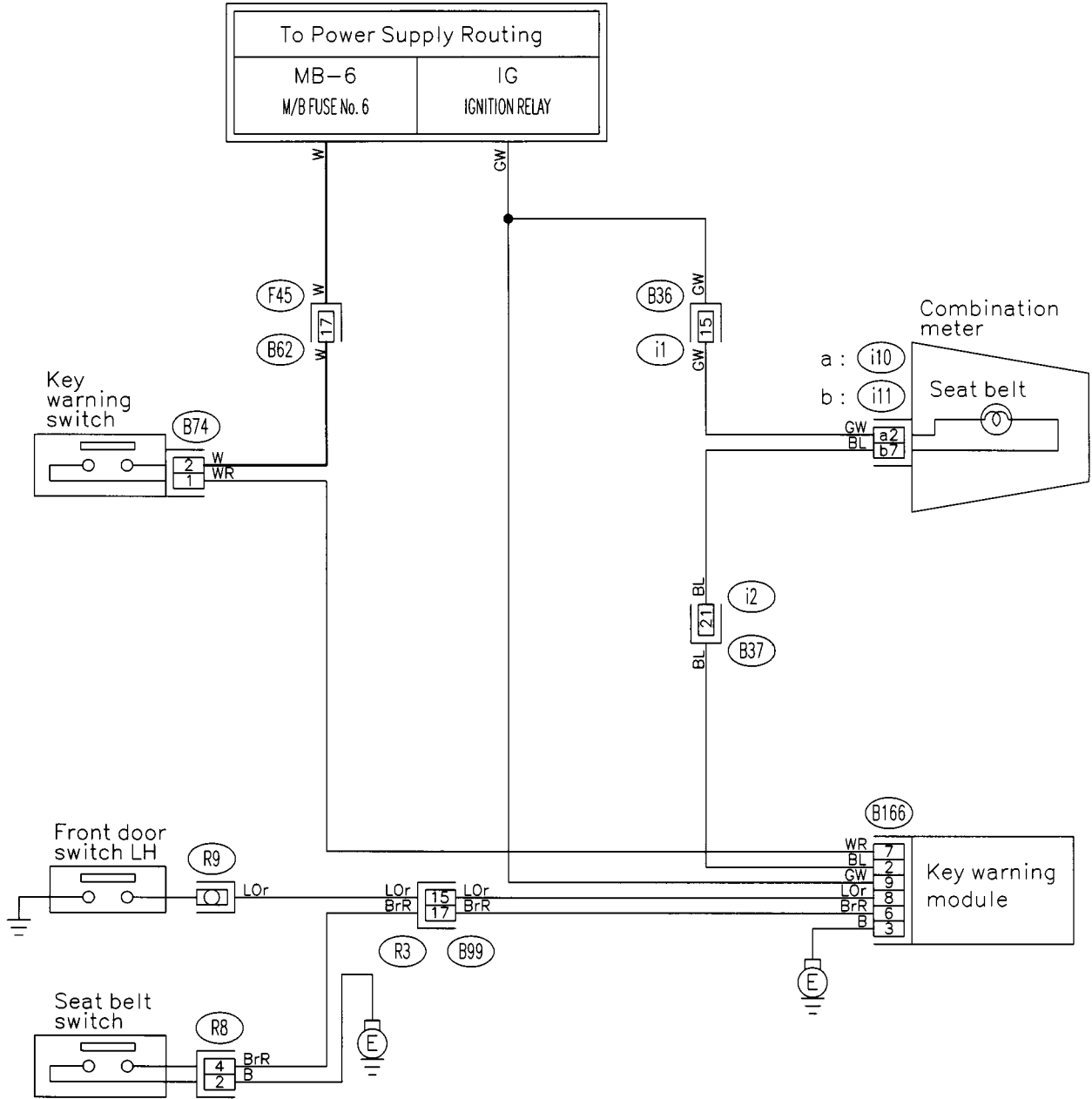

SU87-03

SU87-03

AH: SEAT HEATER SYSTEM

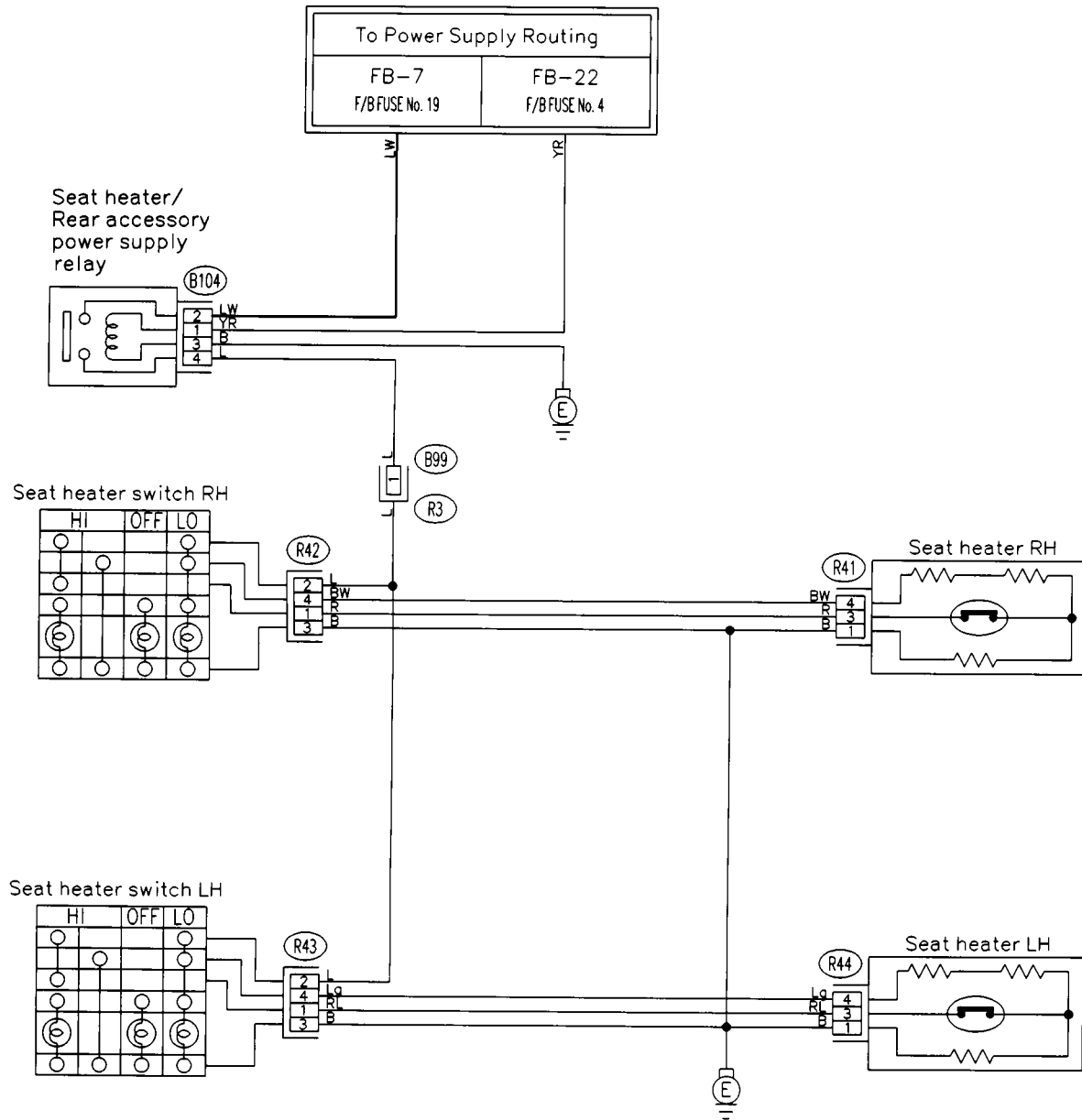

(B99)

(B104)

(R42)

(R43) (Blue)

(R41) (Blue)

(R44) (Blue)

SU84-02

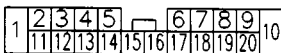

SU84-02

AI: STARTER SYSTEM

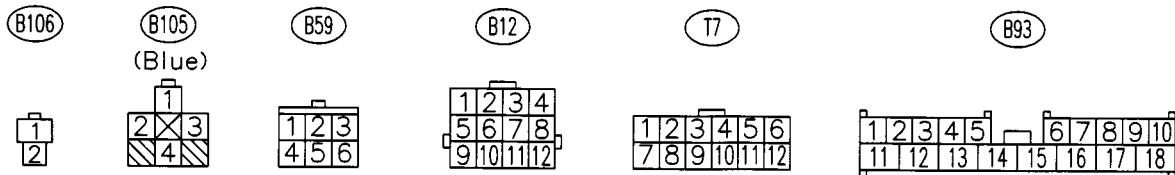
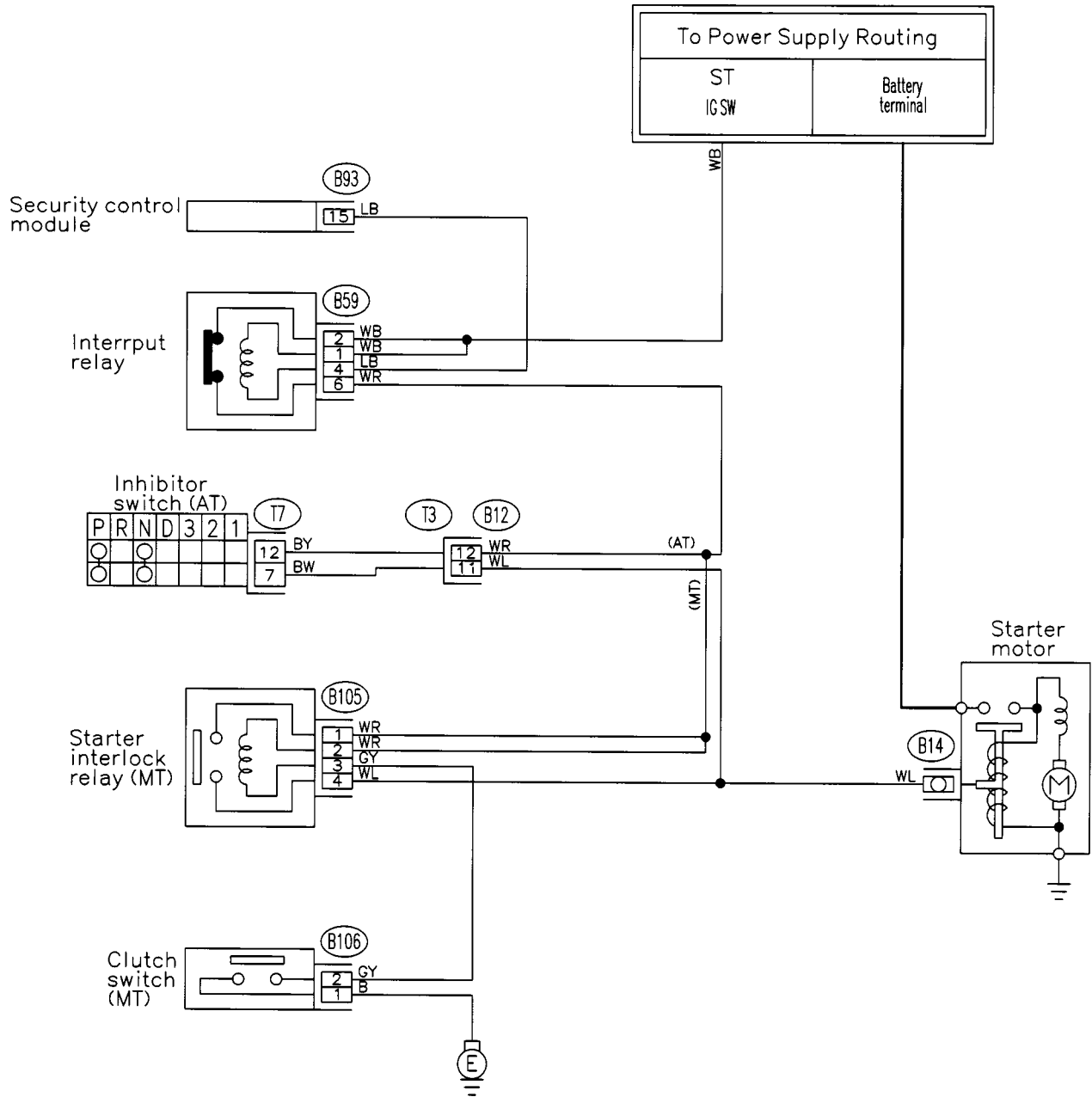

SU03-06

SU03-06

AJ: SUNROOF SYSTEM

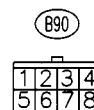
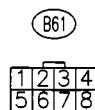
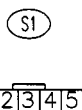
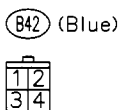
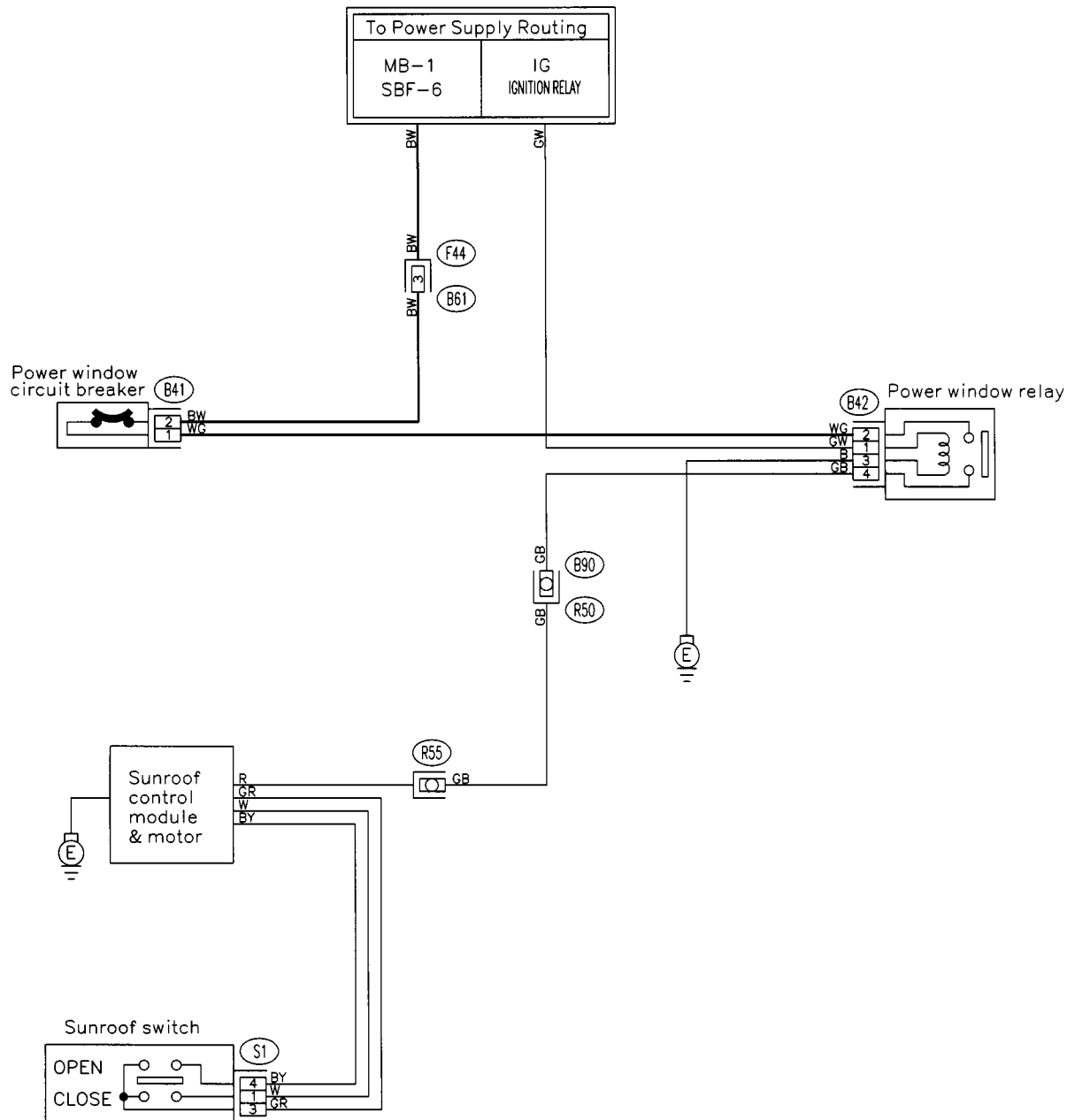

SU75-01

SU75-01

AK: TRAILER WIRE HARNESS (OPTION)

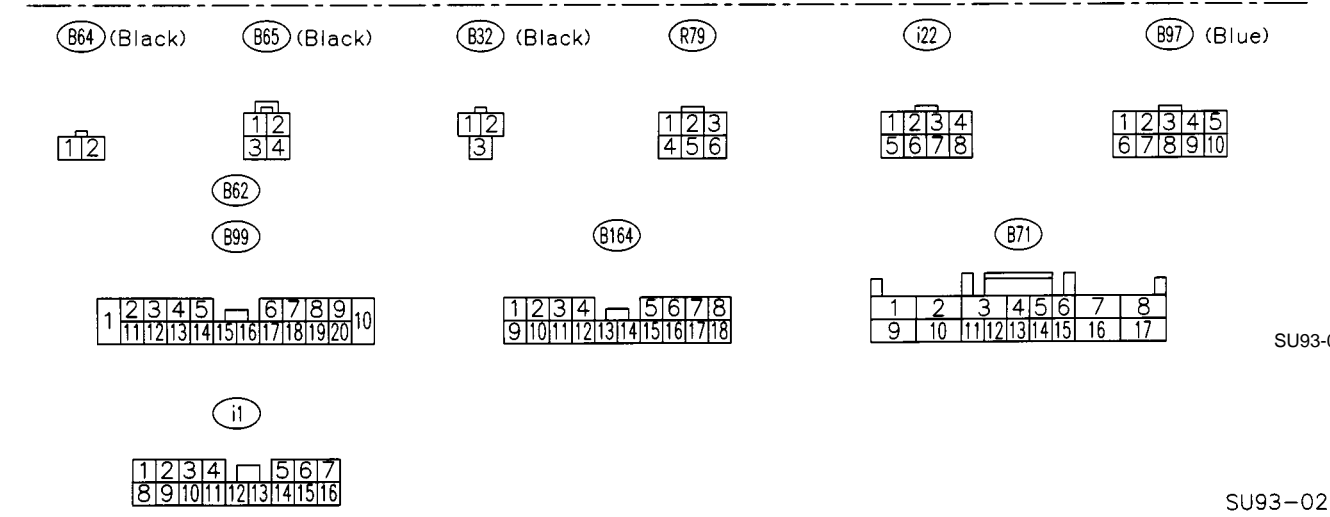
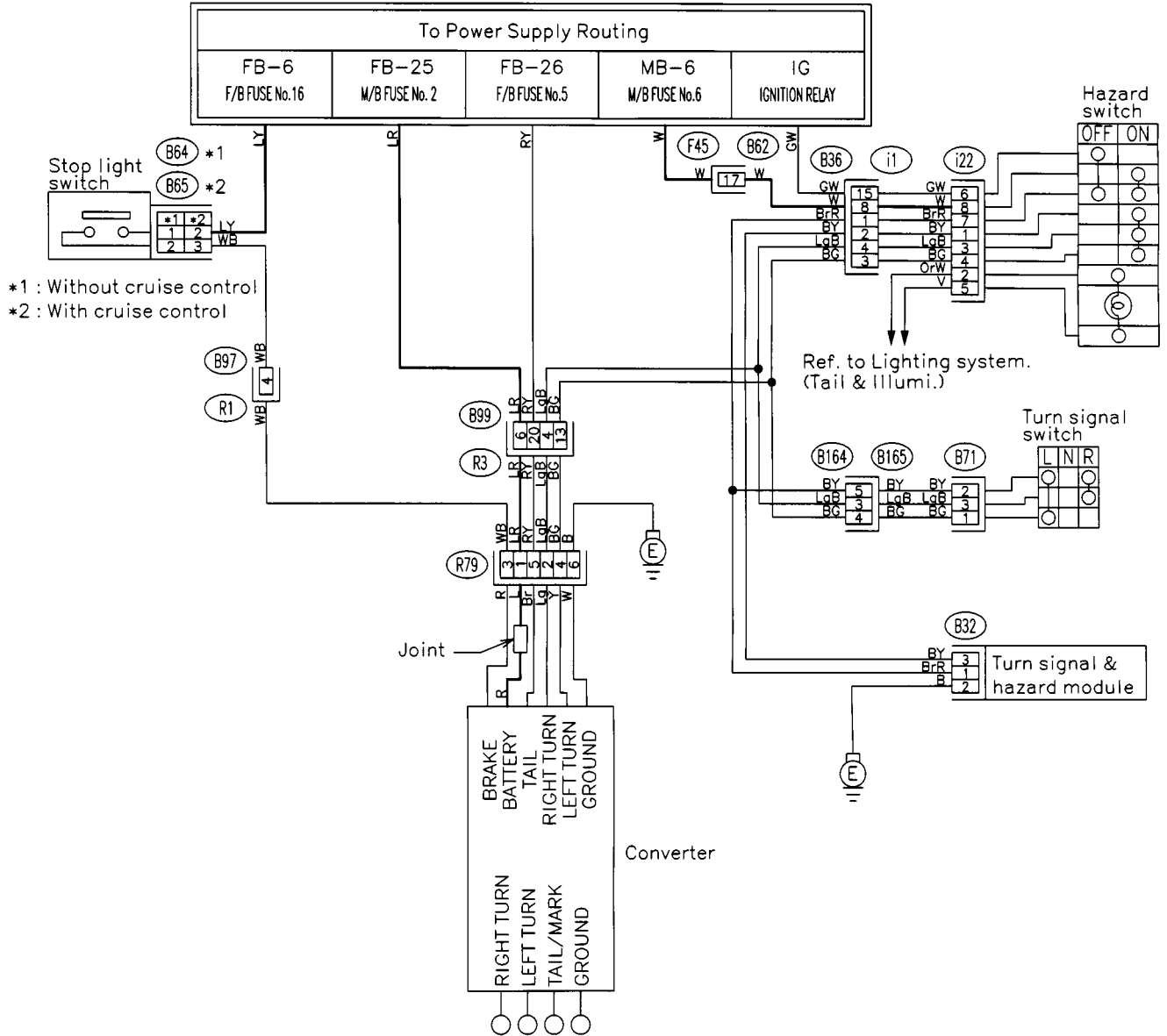

SU93-02

SU93-02

AL: WIPER AND WASHER SYSTEM (FRONT)

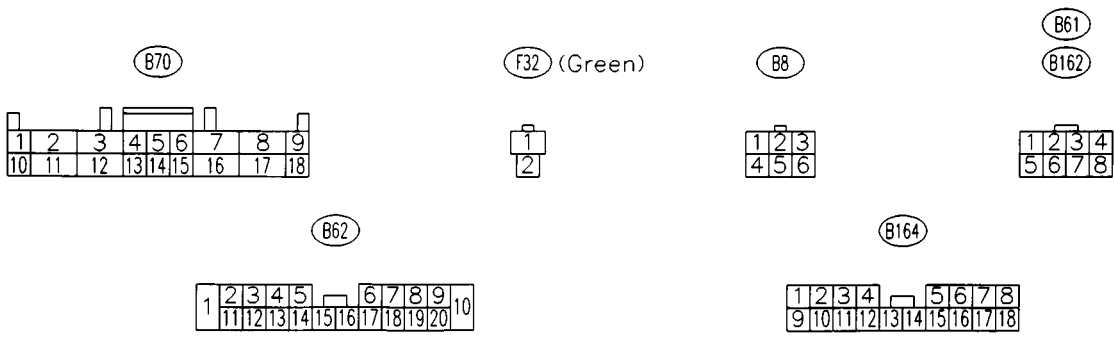
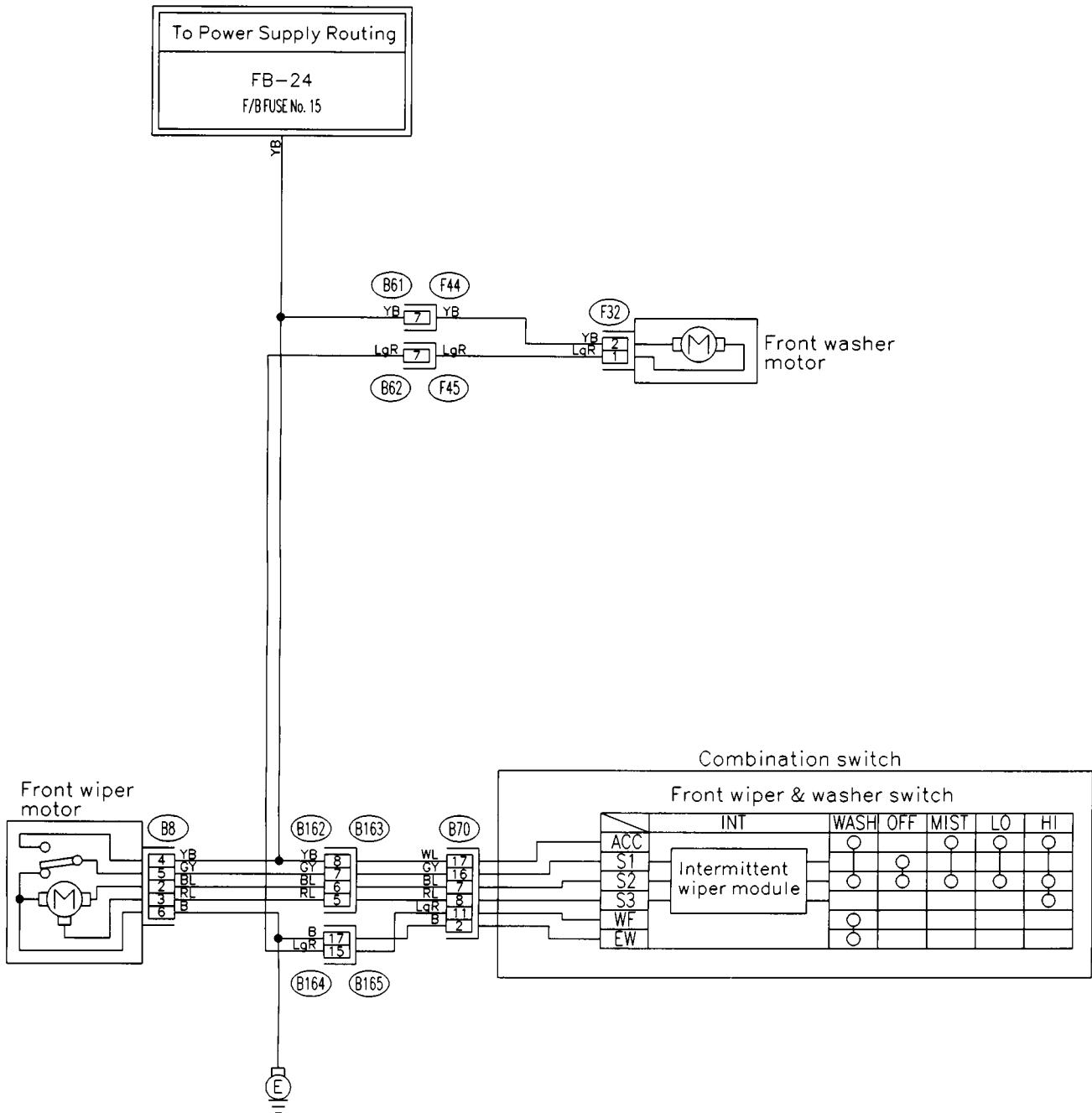

SU50-02

SU50-02

AM: WIPER AND WASHER SYSTEM (REAR)

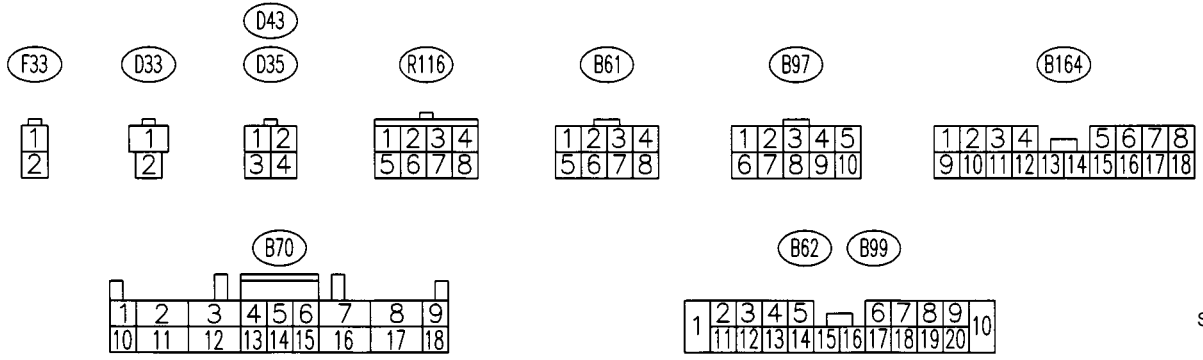
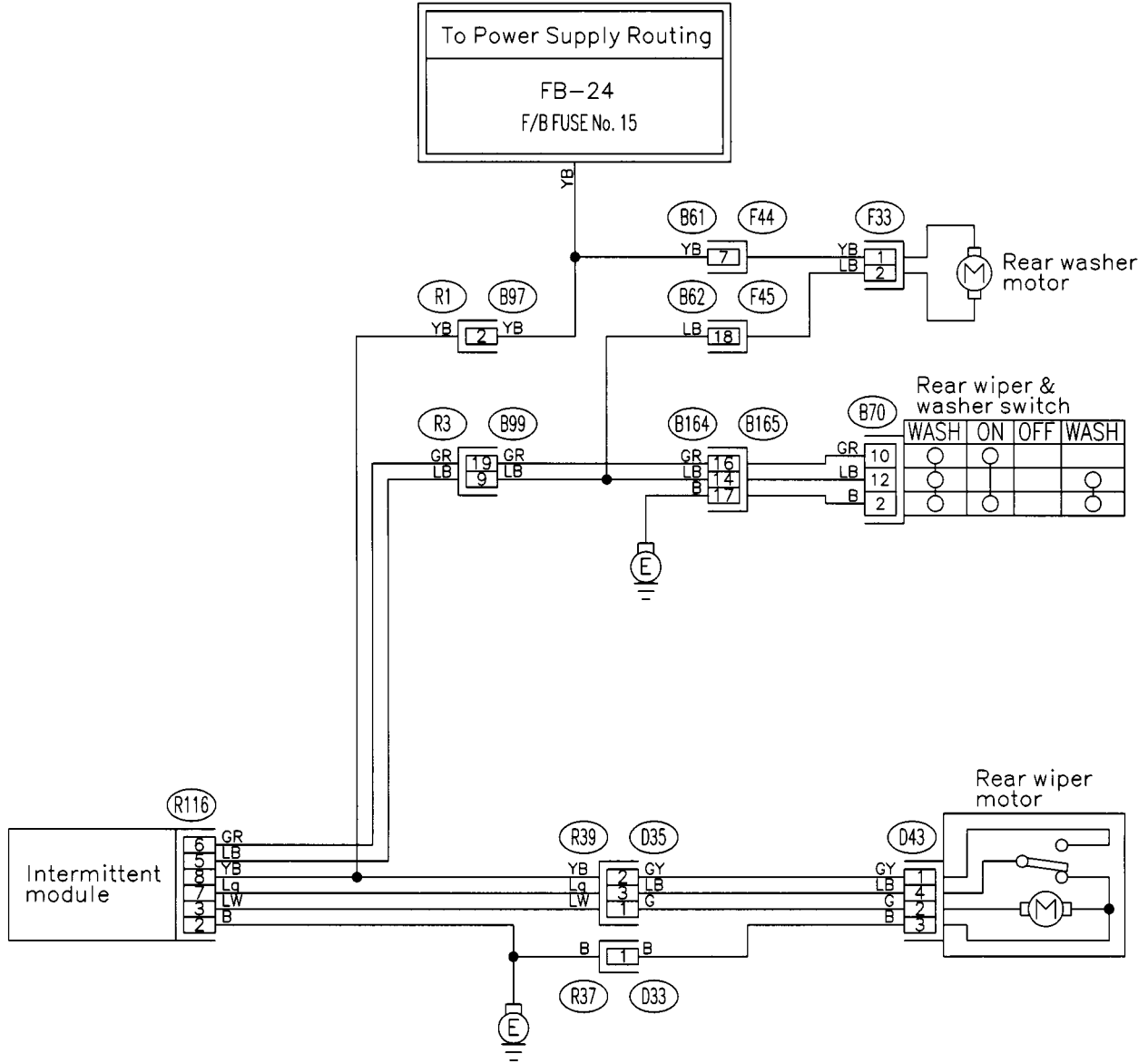

SU51-03

SU51-03

AN: WIPER DEICER SYSTEM

MEMO:

6. Electrical Wiring Harness and Ground Point

A: OVERALL LOCATION

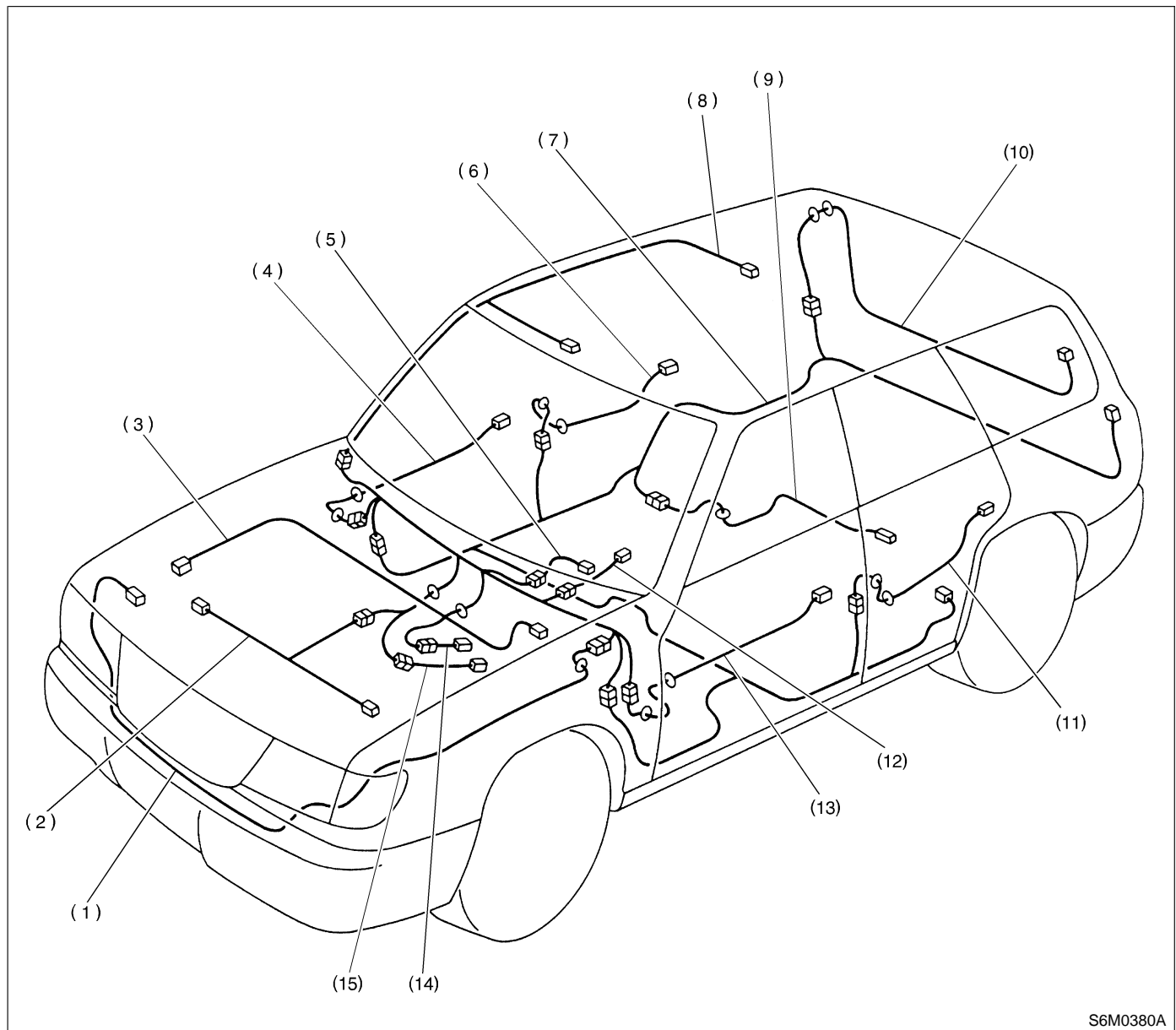

S6M0380A

- | | | |
|-------------------------------------|-------------------------|------------------------------|
| (1) Front wiring harness | (6) Rear door cord RH | (11) Rear door cord LH |
| (2) Engine wiring harness | (7) Rear wiring harness | (12) Combination switch cord |
| (3) Bulkhead wiring harness | (8) Roof cord | (13) Front door cord LH |
| (4) Front door cord RH | (9) Fuel tank cord | (14) Transmission cord |
| (5) Instrument panel wiring harness | (10) Rear gate cord | (15) Oxygen sensor cord |

B: FRONT WIRING HARNESS**1. LIST OF ITEMS**

Connector				Connecting to	
No.	Pole	Color	Area	No.	Name
F2	16	Black	B-4	B100	Bulkhead wiring harness
F3	3	Gray	B-1		Front turn signal light & clearance light RH
F5	1	★	B-1		Horn
F6	2	Black	B-1		Front fog light RH
F7	3	★	B-1		Headlight RH
F16	2	Black	B-1		Sub fan motor
F17	2	Black	B-2	B-2	Radiator main fan motor
F19	3	Gray	C-3		Front turn signal light & clearance light LH
F21	2	Black	C-2		Front fog light LH
F23	3	★	B-2		Headlight LH
F24	1	Gray	B-2		A/C compressor
F25	1	★	B-2		Generator
F26	3	Green	B-2		
F27	4	★	B-3		A/C fuse (Relay holder)
F28	4	★	B-3		A/C sub fan relay (Relay holder)
F31	4	★	B-3		A/C relay (Relay holder)
F32	2	Green	B-3		Front washer motor
F33	2	★	B-3		Rear washer motor
F34	4	★	B-3		SBF holder (ABS)
F35	2	★	B-3		M/B
F36	3	★	B-3		
F37	6	Black	B-3		
F38	1	★	B-3		
F39	8	Black	B-3		
F40	9	Brown	B-4		F/B
F41	7	Gray	B-4		
F44	8	★	B-4	B61	Bulkhead wiring harness
F45	20	★	B-4	B62	
F46	8	★	B-4	B108	
F47	1	★	B-2		Horn
F49	31	★	B-2		ABS control module
F55	12	★	B-4	R48	Rear wiring harness (ABS)
F62	6	★	B-1	F63	Shield joint connector (ABS)
F63	6	★	B-1	F62	
F64	1	★	B-2		ABS motor ground
F65	4	★	B-3		Front fog light relay (Relay holder)
F66	4	★	B-3		Radiator main fan relay (Relay holder)
F67	2	★	B-3		FWD switch (Relay holder)
F68	4	Black	B-3		M/B
F78	2	Black	C-2		Outside temperature sensor

★: Non-colored

2. LOCATION

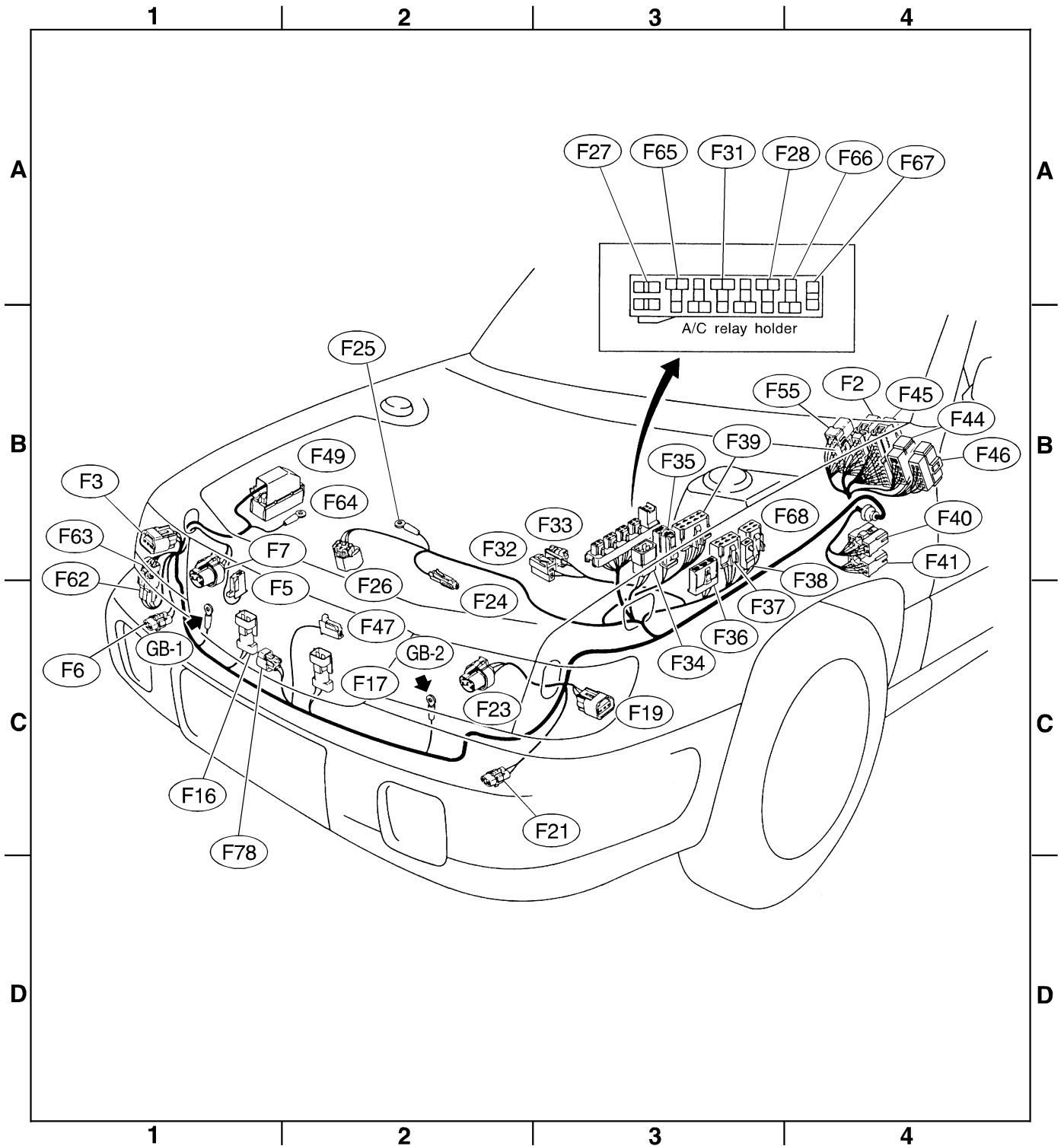

S6M0474A

C: BULKHEAD WIRING HARNESS (IN ENGINE ROOM)**1. LIST OF ITEMS**

Connector				Connecting to	
No.	Pole	Color	Area	No.	Name
B2	3	★	B-1		Atmospheric pressure sensor
B4	4	Gray	B-1		AT dropping resistor
B5	2	Gray	B-2		Resistor (Daytime running light)
B6	2	Brown	B-2		ABS front sensor RH
B7	4	★	B-2		Cruise control actuator
B8	6	★	A-2		Front wiper motor
B10	2	Gray	B-2		A/C pressure switch
B11	20	Black	B-3	T4	Transmission (AT)
B12	12	★	B-3	T3	
B14	1	★	B-3		Starter (Magnet)
B15	2	Brown	B-3		ABS front sensor LH
B16	2	Gray	B-3		Brake fluid level switch
B17	3	★	B-2		Vehicle speed sensor (M/T)
B20	10	★	B-2	E1	Oxygen sensor cord
B21	20	★	B-2	E2	Engine wiring harness
B22	16	★	B-2	E3	Engine wiring harness
B24	2	Gray	B-3	T1	Back-up light switch (MT)
B25	2	Brown	B-3	T2	Neutral position switch (MT)

★: Non-colored

2. LOCATION

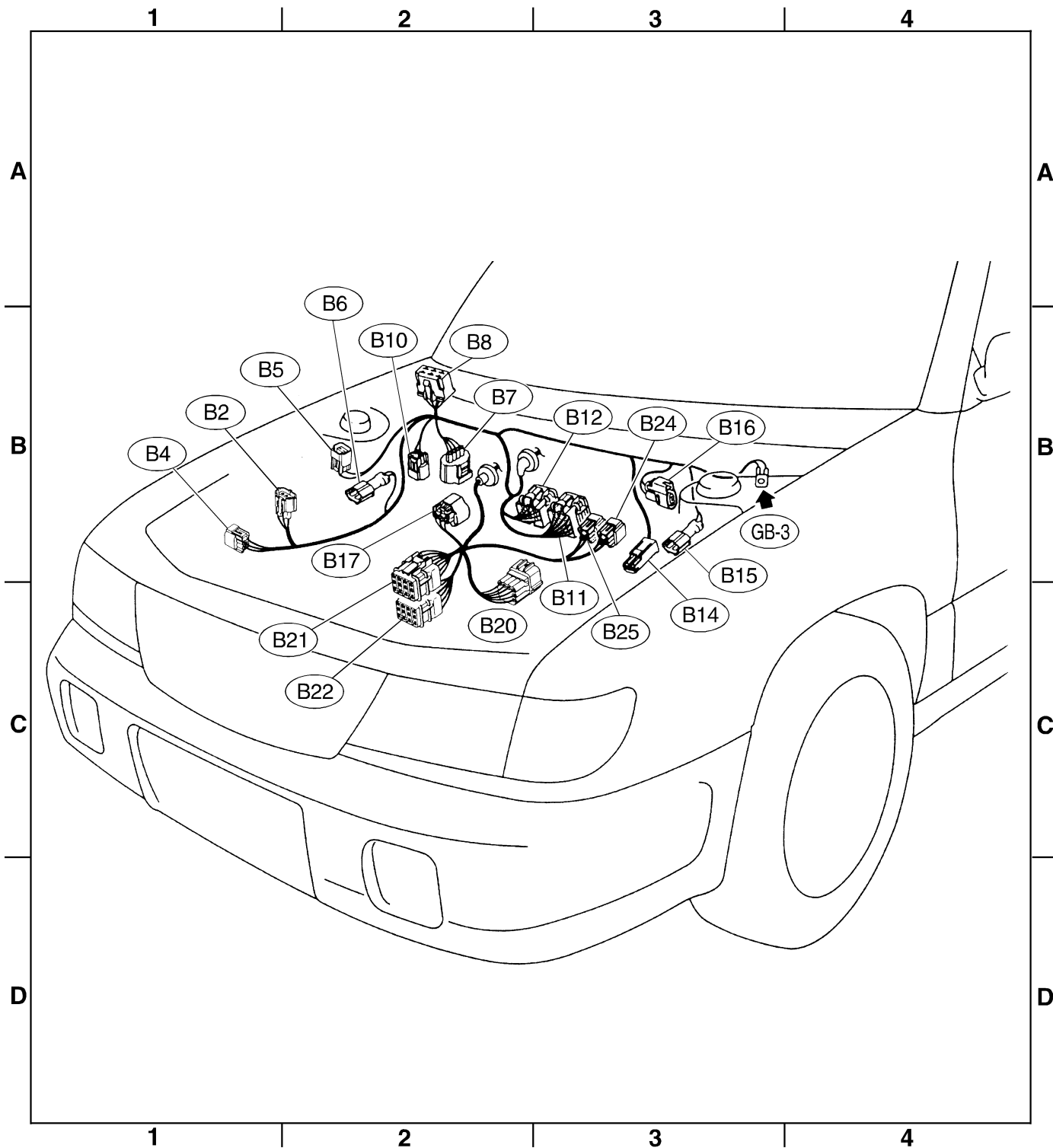

S6M0381A

D: BULKHEAD WIRING HARNESS (IN COMPARTMENT)

1. LIST OF ITEMS

Connector				Connecting to	
No.	Pole	Color	Area	No.	Name
B30	24	★	C-1	D1	Front door cord LH
B31	7	★	C-1	AB1	SRS (Airbag) harness
B32	3	Black	B-1		Turn & hazard module
B36	16	★	B-2	i1	Instrument panel meter harness
B37	24	Blue	B-2	i2	
B40	16	★	C-2		OBD-II service connector
B41	2	★	B-1		Power window circuit breaker
B42	4	Blue	C-1		Power window relay
B43	6	Black	B-4		Illumination control module
B46	4	Green	C-1		Fuel pump relay
B47	6	Brown	C-1		Main relay
B50	4	★	B-1		Blower relay
B51	8	Blue	C-1		F/B
B52	12	Blue	C-1		
B53	6	★	C-2		Shield joint connector (AT)
B54	24	★	C-2		Transmission control module
B55	24	Gray	C-2		
B57	12	★	B-1		Shift lock control module
B59	6	★			Interrupt relay
B61	8	★	B-1	F44	Front wiring harness
B62	20	★	B-1	F45	
B64	2	Black	B-2		Stop light switch
B65	4	Black	B-2		Stop & brake switch (With cruise control)
B68	5	Black	C-2		Cruise control sub switch
B69	4	★	C-2		
B70	18	★	C-2		Combination switch
B71	17	★	C-2		
B72	4	Blue	C-2		Ignition switch
B73	2	★	C-2		Key lock solenoid (AT)
B74	2	Black	C-2		Key warning switch
B75	2	Green	B-2	B76	Test mode connector
B76	2	Green	B-2	B75	
B79	14	Gray	C-3		Check connector
B81	1 × 2	★	B-2		Diagnosis terminal (Ground)
B82	6	Black	B-2		Diagnosis connector
B83	6	★	C-4		Shield joint connector (E/G)
B86	6	★	B-3		Blower motor resistor
B87	2	★	B-4		Blower motor
B88	3	★	B-3		Evaporator thermostwitch
B90	8	★	B-4	R50	Roof cord
B93	18	★	C-1		Security control module
B94	20	★	C-1		Cruise control module
B95	2	★	B-4		Diode (Daytime running light)
B96	10	★	B-4		Daytime running light control module
B97	10	Blue	C-4	R1	
B98	12	Black	C-4	R2	Rear wiring harness
B99	20	★	C-4	R3	
B100	16	Black	B-1	F2	Front wiring harness (With ABS model)
B101	24	★	C-4	D11	Front door cord RH
B102	5	Black	B-2		Daytime running light relay

Connector				Connecting to	
No.	Pole	Color	Area	No.	Name
B103	4	Blue	B-2		HI-beam relay (Daytime running light)
B104	4	★	C-1		Seat heater/rear accessory power supply relay
B105	4	Blue	B-2		Starter interlock relay (MT)
B106	2	★	B-2		Clutch switch (MT)
B107	2	Blue	B-2		Clutch switch (Cruise control)
B108	8	★	B-1	F46	Front wiring harness
B112	2	★	B-2		Diode (Front fog light)
B116	4	Black	C-3		Select lever illumination light (AT)
B117	4	★	C-3		Parking position switch & shift lock solenoid (AT)
B118	2	★	C-3		CD player illumination light
B119	1	★	C-3		Front accessory power supply (Power)
B120	14	★	C-3		Radio
B121	1	★	C-3		Audio ground
B122	6	★	C-4		Sensor ground joint connector (E/G)
B125	1	Green	C-4	B126	Test mode connector
B126	1	Green	C-4	B125	
B134	35	Black	C-3		
B135	28	Black	C-3		Engine control module
B136	30	Black	C-3		
B152	7	★	C-1		F/B
B157	4	Red	C-1		Ignition relay
B158	12	★	C-1		F/B
B159	10	Gray	C-1		F/B
B160	6	Gray	C-1		Front fog light switch
B161	6	Brown	C-1		Cruise control main switch
B162	8	★	C-2	B163	Combination switch cord
B163	8	★	C-2	B162	Bulkhead wiring harness
B164	18	★	C-2	B165	Combination switch cord
B165	18	★	C-2	B164	Bulkhead wiring harness
B166	10	★	C-2		Key warning module
B167	3	★	C-3		Front accessory power supply (Ground)
B168	3	★	B-3		A/C switch
B169	6	★	B-3		Blower fan switch
B170	2	★	B-3		Mode control panel illumination light
B171	4	Black	B-4		Mirror heater relay
B173	1	★	C-1		IG power supply connector
B175	2	★	C-3		Ash tray illumination light
B176	16	★	C-2		Keyless entry control module
B177	2	★	B-1		Wiper deicer
B183	1	★	B184		Program connector +
B184	1	★	B183		Program connector -
B191	4	Blue	B-4		Wiper deicer relay
B192	4	★	B-4		Wiper deicer timer
B193	6	★	C-1		Wiper deicer switch
B203	4	Black	C-1		Noise killer

★: Non-colored

E: ENGINE WIRING HARNESS AND TRANSMISSION CORD**1. LIST OF ITEMS**

Connector				Connecting to	
No.	Pole	Color	Area	No.	Name
E1	10	★	C-1/C-3	B20	Bulkhead wiring harness
E2	20	Gray	A-3	B21	
E3	16	Gray	A-3	B22	
E4	2	★	A-2		Purge control solenoid valve
E5	2	★	A-2		Injector #1
E6	2	★	A-2		Injector #3
E7	6	★	A-2		Idle air control solenoid valve
E8	3	★	B-2		Engine coolant temperature sensor and thermometer
E10	2	★	B-2		Crankshaft position sensor
E11	1	★	B-2		Oil pressure switch
E12	4	Dark gray	A-3		Ignition coil and ignitor
E13	4	★	A-3		Throttle position sensor
E14	2	Gray	B-3		Knock sensor
E15	2	★	B-3		Camshaft position sensor
E16	2	★	B-3		Injector #2
E17	2	★	B-4		Injector #4
E19	2	★	B-3		Power steering oil pressure switch
E21	4	★	A-3		Pressure sensor and intake air temperature sensor
E24	6	★	D-1/D-3		Front oxygen (A/F) sensor
E25	4	★	D-2/D-4		Rear oxygen sensor
E42	2	★	A-3		Air assist solenoid valve

★: Non-colored

Connector				Connecting to	
No.	Pole	Color	Area	No.	Name
T1	2	Gray	C-1	B24	Bulkhead wiring harness (MT)
T2	2	Brown	C-1	B25	
T3	12	★	D-3	B12	Bulkhead wiring harness (AT)
T4	20	★	D-3	B11	
T7	12	★	C-4		Inhibitor switch (AT)
T8	2	Gray	D-1	B29	Bulkhead wiring harness (MT)
T12	3	★	C-2		Speed sensor cord (MT)

★: Non-colored

2. LOCATION

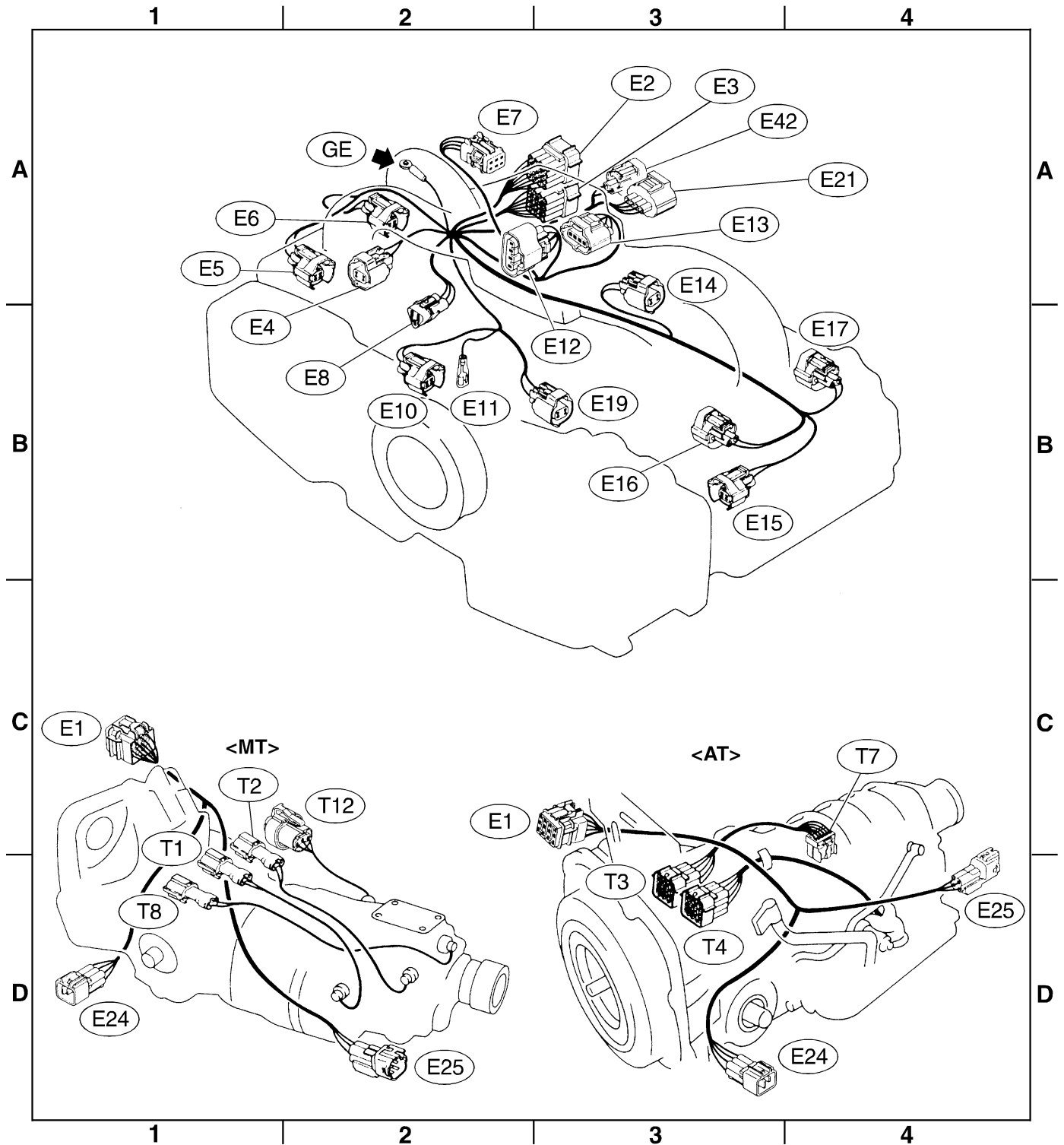

S6M0383A

F: INSTRUMENT PANEL WIRING HARNESS**1. LIST OF ITEMS**

Connector				Connecting to	
No.	Pole	Color	Area	No.	Name
i1	16	★	B-2	B36	Bulkhead wiring harness
i2	24	Blue	B-2	B37	
i10	18	★	B-2		Combination meter
i11	10	★	B-2		
i12	16	★	B-2		
i18	8	★	B-3		Rear defogger switch
i22	8	★	B-3		Hazard switch

★: Non-colored

2. LOCATION

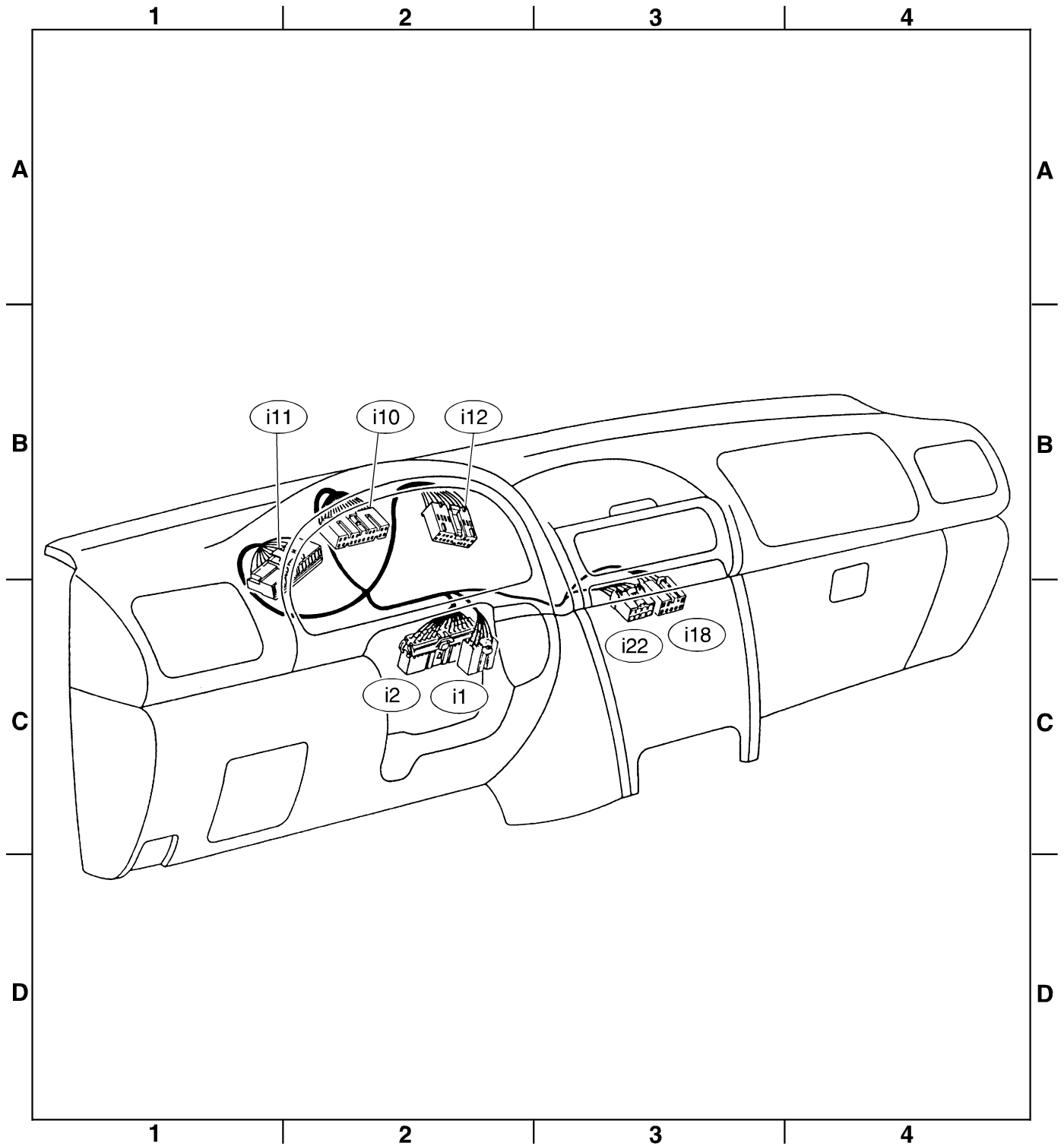

S6M0476A

G: REAR WIRING HARNESS

1. LIST OF ITEMS

Connector				Connecting to	
No.	Pole	Color	Area	No.	Name
R1	10	Blue	B-2	B97	Bulkhead wiring harness
R2	12	Black	B-2	B98	
R3	20	★	B-2	B99	
R4	1	Black	B-3		Parking brake switch
R8	4	★	B-3		Seat belt switch
R9	1	★	B-3		Front door switch LH
R11	4	★	B-3	D21	Rear door cord LH
R12	1	★	B-2		Front door switch RH
R14	4	★	B-2	D27	Rear door cord RH
R15	12	★	B-3	R57	Fuel tank cord
R16	1	Brown	B-3		Rear door switch RH
R22	1	Brown	B-4		Rear door switch LH
R26	6	★	A-3		Rear combination light RH
R28	6	★	B-4		Rear combination light LH
R30	2	★	A-3		Diode (Luggage room light)
R32	3	★	A-3		Rear accessory power supply
R37	2	★	A-3	D33	Rear gate cord
R38	6	★	A-3	D34	
R39	4	★	A-3	D35	
R41	4	Blue	B-2		Seat heater RH
R42	4	★	B-3		Seat heater switch RH
R43	4	Blue	B-3		Seat heater switch LH
R44	3	Blue	B-3		Seat heater LH
R46	2	★	B-3	R67	Fuel tank cord
R47	3	★	B-3		Fuel tank pressure sensor
R48	12	★	C-3	F55	Front wiring harness (ABS)
R50	8	★	B-2	B90	Bulkhead wiring harness (With sunroof)
R52	2	★	A-3		Room light (With sunroof)
	3	★	A-3		Room light (Without sunroof)
R55	1	★	B-3		Sunroof motor
R56	2	★	A-2		Spot light
R57	8	★	B-3	R15	Rear wiring harness
R58	6	★	B-3		Fuel gauge module & fuel pump assembly
R59	2	★	B-3		Fuel gauge sub module
R63	4	★	B-4		License plate light
R67	2	★	B-3	R46	Rear wiring harness
R68	2	★	B-3		Pressure control solenoid valve
R69	2	★	B-3		Vent control solenoid valve
R70	3	★	B-2		ABS G sensor
R72	2	★	B-3		Rear ABS sensor RH
R73	2	★	B-4		Rear ABS sensor LH
R79	6	★	B-3		Trailer connector
R80	3	★	B-2	D64	Rear door cord RH
R81	3	★	B-3	D63	Rear door cord LH
R82	4	★	A-3		Clock
R97	2	Brown	B-4		Antenna amplifier
R116	8	★	A-3		Rear wiper intermittent module
R139	3	★	B-2		Compass mirror

★: Non-colored

2. LOCATION

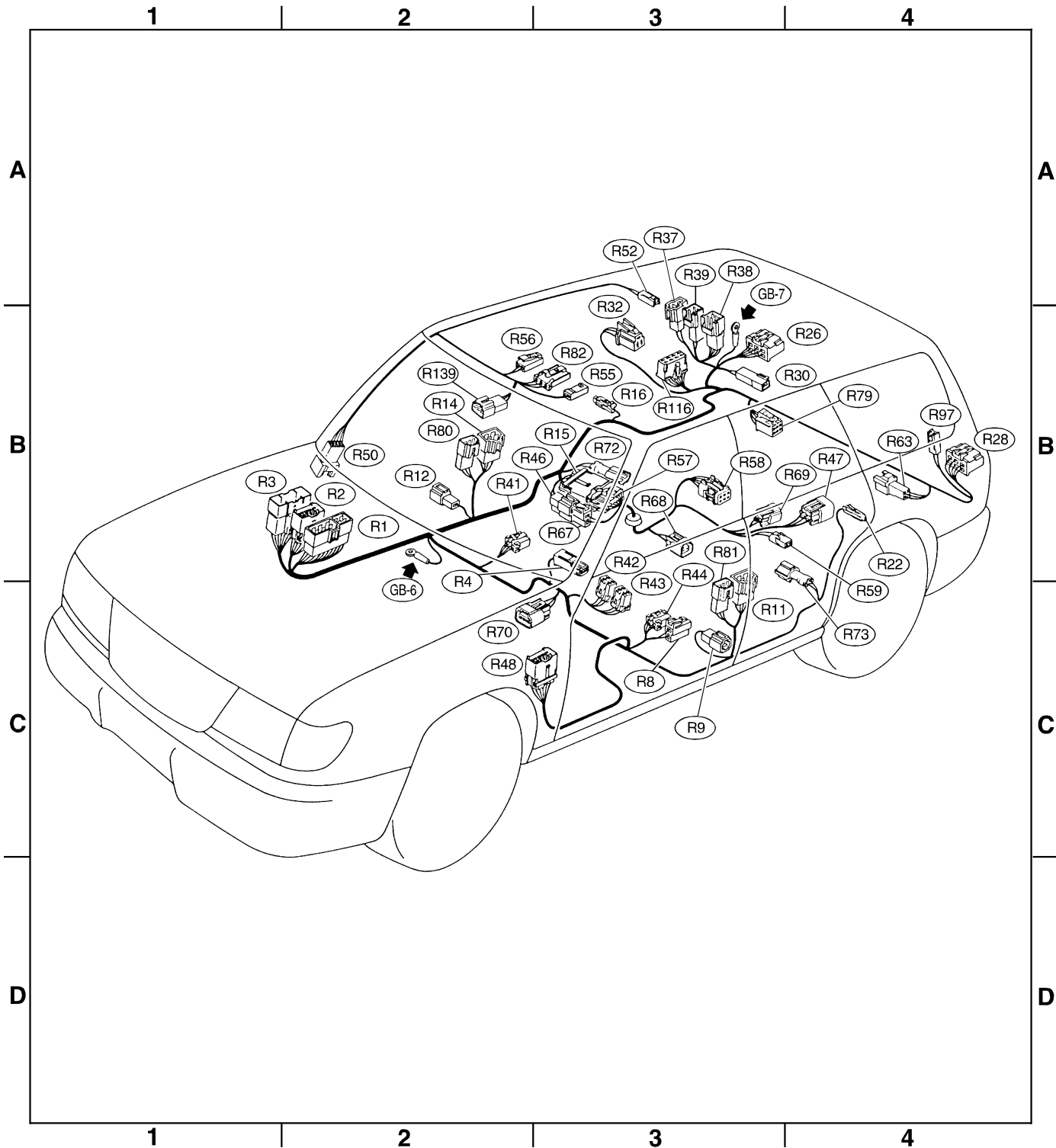

S6M0477A

H: DOOR CORD**1. LIST OF ITEMS**

Connector				Connecting to	
No.	Pole	Color	Area	No.	Name
D1	24	★	C-2	B30	Bulkhead wiring harness
D2	2	★	C-3		Front door speaker LH
D3	2	Blue	C-3		Front power window motor LH
D4	2	Black	B-3		Front door tweeter LH
D5	6	★	B-3		Remote control rearview mirror LH
D6	2	★	B-3		Mirror heater LH
D7	16	★	B-3		Power window main switch
D8	4	★	B-3		Front door lock actuator LH
D11	24	★	B-2	B101	Bulkhead wiring harness
D12	2	★	B-2		Front door speaker RH
D13	2	Blue	B-2		Front power window motor RH
D14	2	Black	B-2		Front door tweeter RH
D15	6	★	B-2		Remote control rearview mirror RH
D16	2	★	B-2		Mirror heater RH
D17	8	★	B-2		Front power window sub switch RH
D18	4	★	B-2		Front door lock actuator RH
D21	4	★	C-3	R11	Rear wiring harness
D23	2	★	C-4		Rear door speaker LH
D24	2	Blue	B-4		Rear power window motor LH
D25	6	★	B-4		Rear power window sub switch LH
D26	4	★	B-4		Rear door lock actuator LH
D27	4	★	B-2	R14	Rear wiring harness
D29	2	★	B-3		Rear door speaker RH
D30	2	Blue	B-2		Rear power window motor RH
D31	6	★	B-3		Rear power window sub switch RH
D32	4	★	B-3		Rear door lock actuator RH
D61	10	★	B-3		Remote control rearview mirror switch
D62	8	★	B-2		Door lock switch RH
D63	3	★	C-3	R81	Rear wiring harness
D64	3	★	B-2	R80	Rear wiring harness

★: Non-colored

2. LOCATION

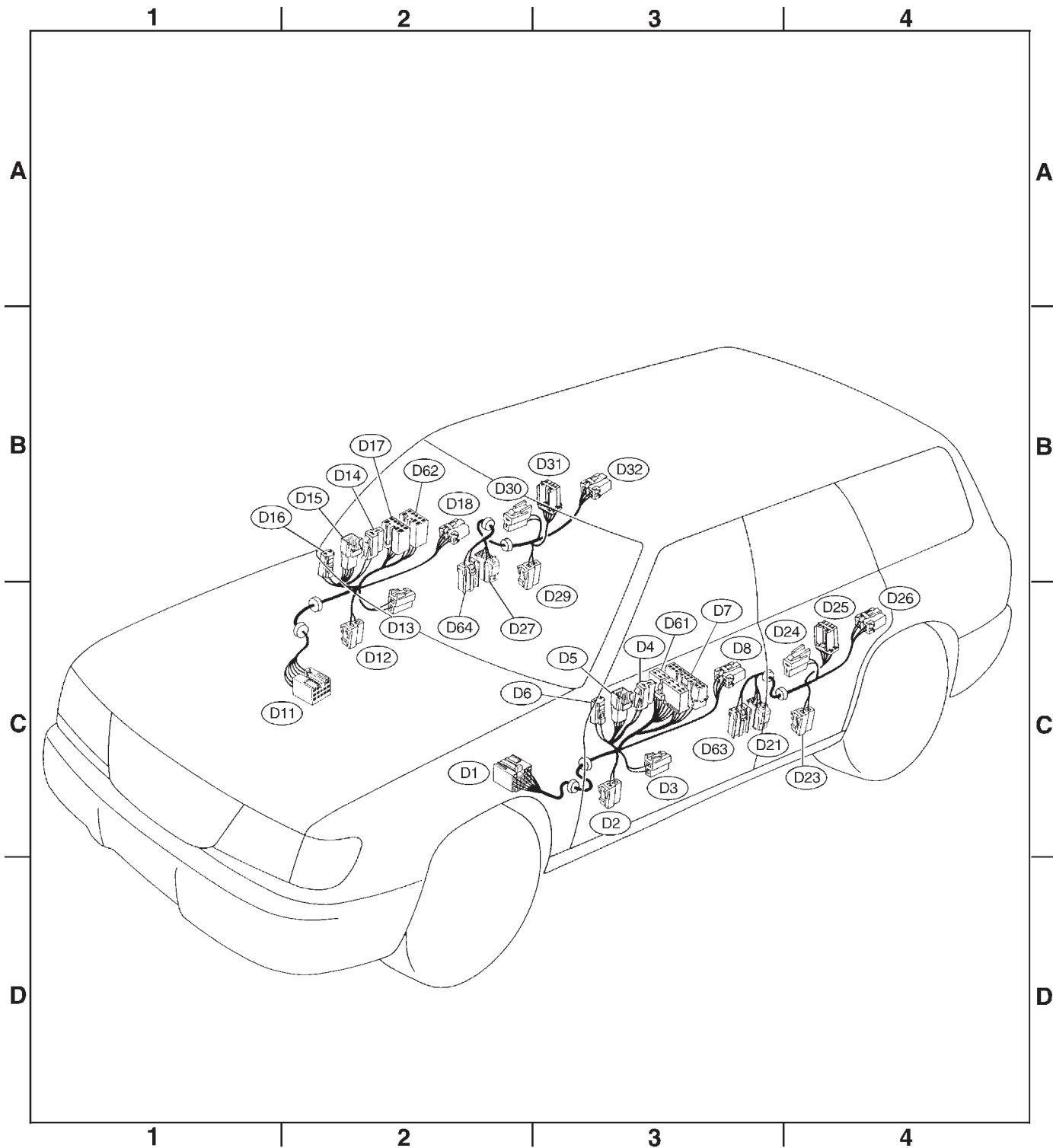

S6M0344A

I: REAR GATE CORD**1. LIST OF ITEMS**

Connector				Connecting to	
No.	Pole	Color	Area	No.	Name
D33	2	★	B-4	R37	Rear wiring harness
D34	6	★	B-4	R38	
D35	4	★	B-4	R39	
D37	1	★	A-3		Luggage room light (Power)
D38	1	Black	A-3		Luggage room light
D39	2	Black	A-3		High-mount stop light
D40	1	Black	B-4		Rear defogger (Power)
D42	3	★	B-4		Rear finisher light RH
D43	4	★	B-3		Rear wiper motor
D46	2	Black	B-3		Rear gate latch switch
D47	4	★	B-4		Rear gate lock actuator
D48	1	Black	B-3		Rear defogger (Ground)
D49	3	★	B-3		Rear finisher light LH

★: Non-colored

2. LOCATION

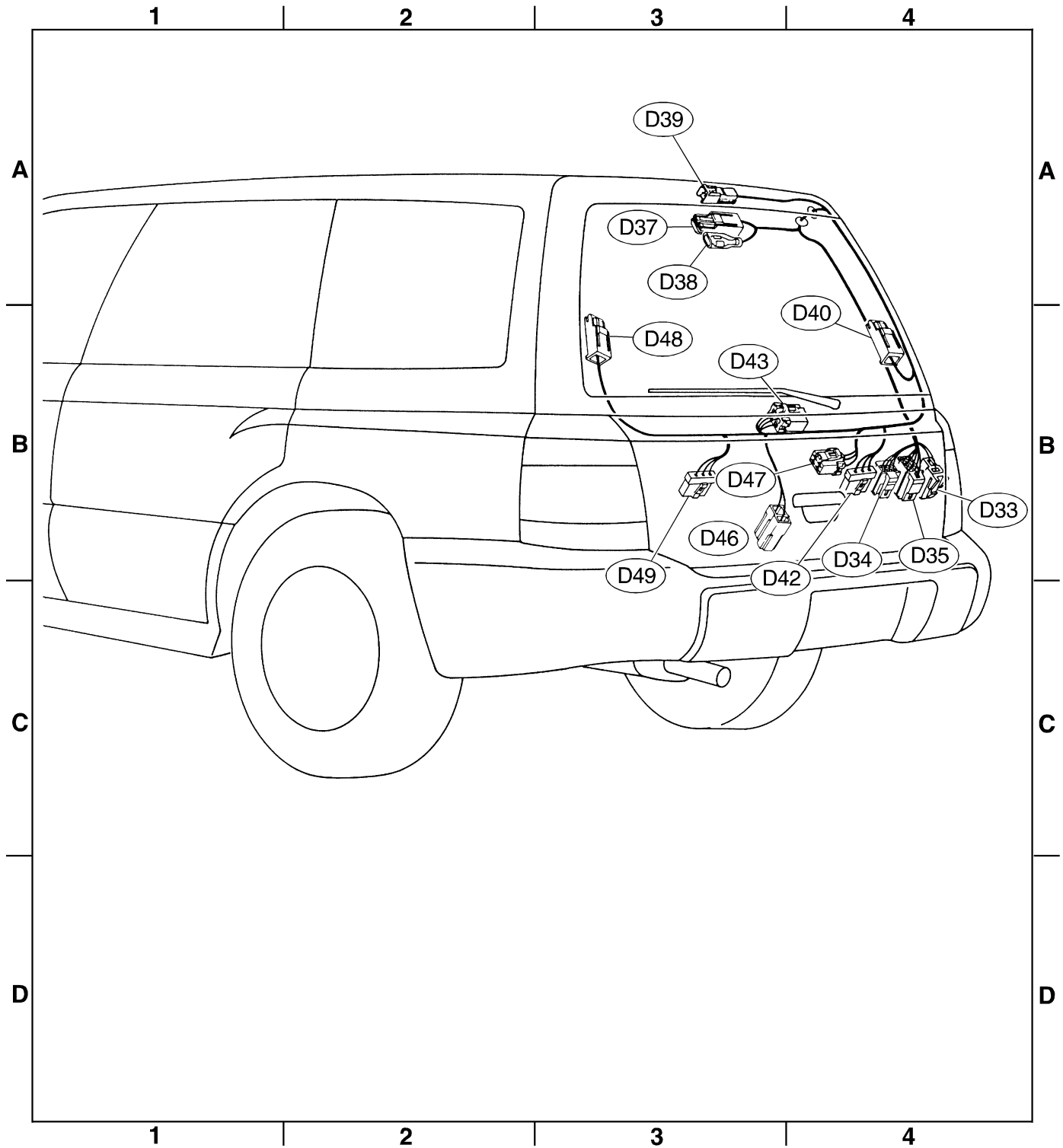

S6M0478A

MEMO: