

TRANSFER CASE AND EXTENSION CASE ASSEMBLY

MANUAL TRANSMISSION AND DIFFERENTIAL

10. Transfer Case and Extension Case Assembly

A: REMOVAL

- 1) Remove the manual transmission assembly from vehicle. <Ref. to 5MT-28, REMOVAL, Manual Transmission Assembly.>
- 2) Remove the back-up light switch and neutral position switch. <Ref. to 5MT-38, REMOVAL, Switches and Harness.>
- 3) Remove the transfer case with extension case assembly.

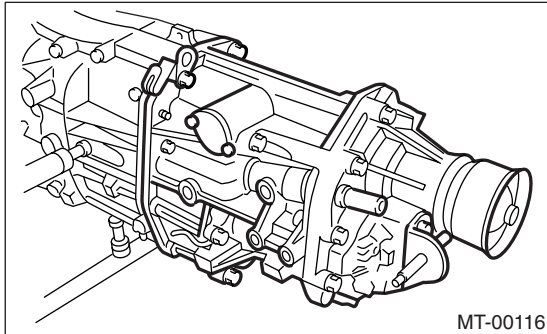

- 4) Remove the shifter arm.
- 5) Remove the extension case assembly.

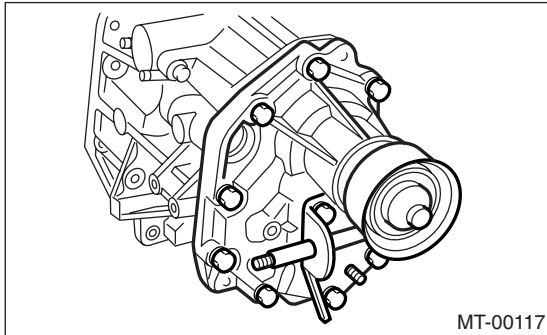

B: INSTALLATION

- 1) Install the center differential and transfer driven gear into transfer case.

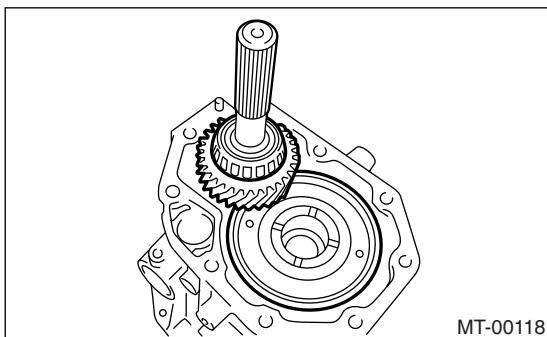

- 2) Remove the bearing outer race from extension case.

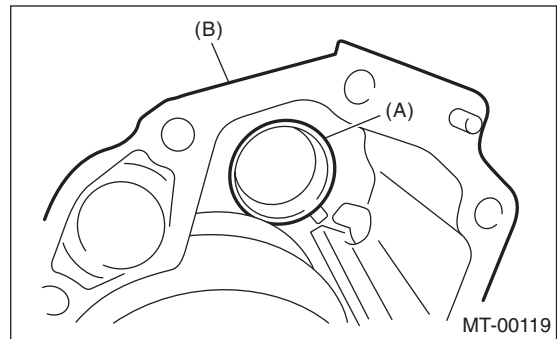

- (A) Bearing outer race
(B) Extension case

- 3) While pressing the bearing outer race horizontally, turn the driven shaft ten rotations.
- 4) Measure the height "W" between transfer case and taper roller bearing on the transfer driven gear.

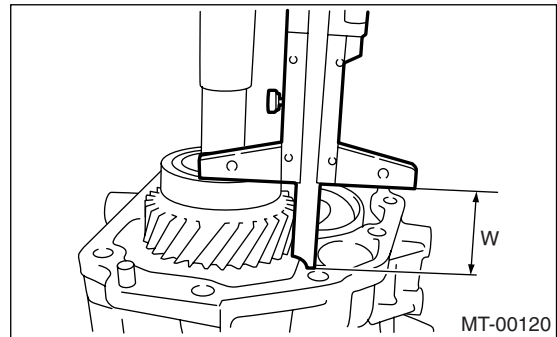

- 5) Measure the depth "X".

NOTE:

Measure with bearing cone and thrust washer removed.

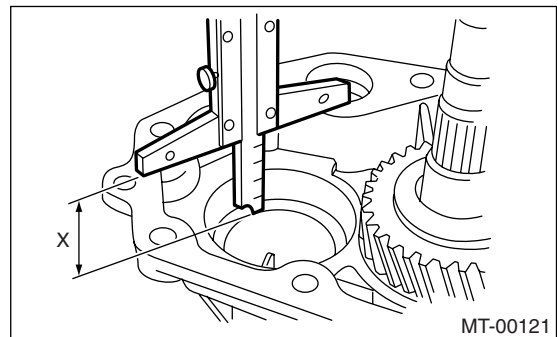

- 6) Calculate the space "t" using the following equation: $t = X - W + 0.2$ to 0.3 mm (0.008 to 0.012 in)
- 7) Select the nearest washer in the following table:

Standard clearance between thrust washer and taper roller bearing:

0.2 — 0.3 mm (0.008 — 0.012 in)

NOTE:

Set the clearance within standard clearance.

TRANSFER CASE AND EXTENSION CASE ASSEMBLY

MANUAL TRANSMISSION AND DIFFERENTIAL

Thrust washer (50 × 61 × t)	
Part No.	Thickness mm (in)
803050060	0.50 (0.0197)
803050061	0.55 (0.0217)
803050062	0.60 (0.0236)
803050063	0.65 (0.0256)
803050064	0.70 (0.0276)
803050065	0.75 (0.0295)
803050066	0.80 (0.0315)
803050067	0.85 (0.0335)
803050068	0.90 (0.0354)
803050069	0.95 (0.0374)
803050070	1.00 (0.0394)
803050071	1.05 (0.0413)
803050072	1.10 (0.0433)
803050073	1.15 (0.0453)
803050074	1.20 (0.0472)
803050075	1.25 (0.0492)
803050076	1.30 (0.0512)
803050077	1.35 (0.0531)
803050078	1.40 (0.0551)
803050079	1.45 (0.0571)

- 8) Fit the thrust washers on transfer drive shaft.
- 9) Install the bearing cone into extension case.
- 10) Measure the depth "S" between transfer case and center differential.

ST 398643600 GAUGE

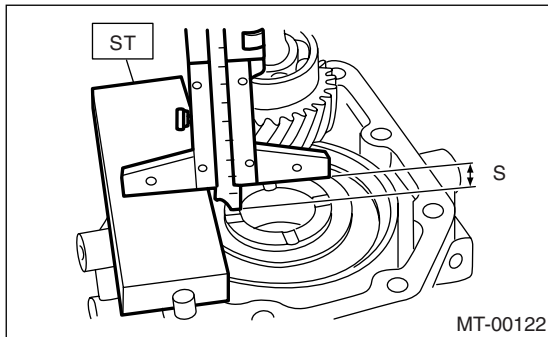

- 11) Measure the depth "T" between extension case and transfer drive gear.

ST 398643600 GAUGE

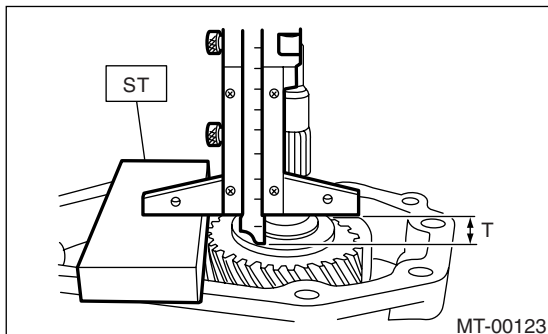

- 12) Calculate the space "U" using the following equation: $U = S + T - 30 \text{ mm (1.18 in)}$ [Thickness of ST]

- 13) Select the suitable washer in the following table:

Standard clearance:

0.15 — 0.35 mm (0.0059 — 0.0138 in)

Thrust washer	
Part No.	Thickness mm (in)
803036050	0.9 (0.035)
803036054	1.0 (0.039)
803036051	1.1 (0.043)
803036055	1.2 (0.047)
803036052	1.3 (0.051)
803036056	1.4 (0.055)
803036053	1.5 (0.059)
803036057	1.6 (0.063)
803036058	1.7 (0.067)

- 14) Fit the thrust washer on center differential.
- 15) Apply proper amount of liquid gasket to the transfer case mating surface.

Liquid gasket:

THREE BOND 1215 (Part No.: 004403007)

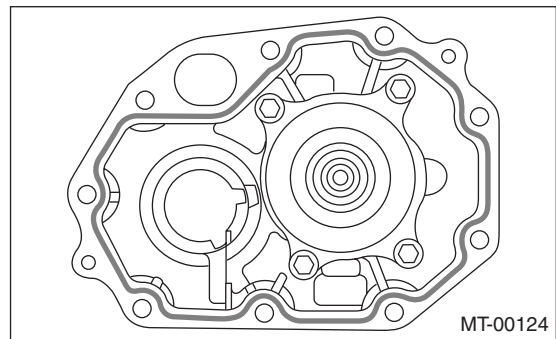

- 16) Install the extension assembly into transfer case.

Tightening torque:

40 N·m (4.1 kgf-m, 29.7 ft-lb)

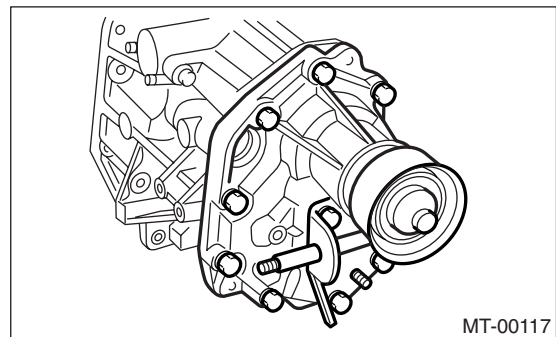

TRANSFER CASE AND EXTENSION CASE ASSEMBLY

MANUAL TRANSMISSION AND DIFFERENTIAL

17) Install the shifter arm to transfer case.

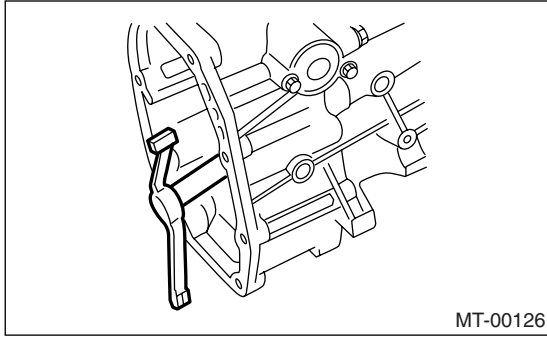

18) Hang the shifter arm on 3rd-4th fork rod.

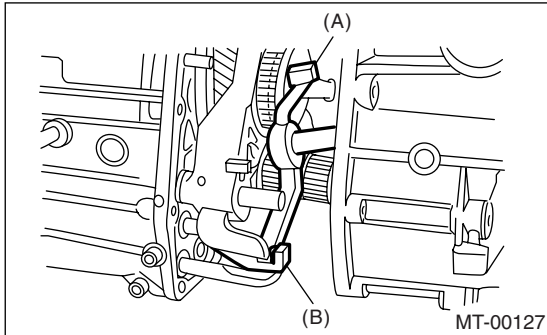

(A) Shifter arm

(B) 3rd-4th fork rod

19) Install the transfer case with extension case assembly to transmission case.

Tightening torque:

24.5 N·m (2.5 kgf-m, 18.1 ft-lb)

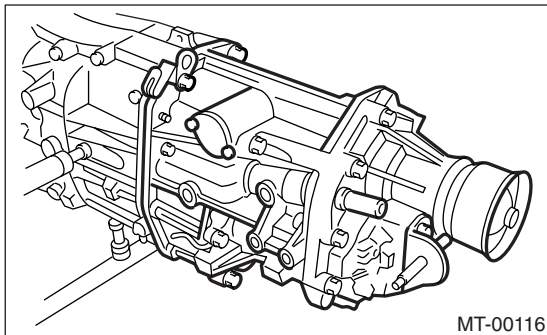

C: DISASSEMBLY

1. TRANSFER CASE

1) Remove the reverse check assembly. <Ref. to 5MT-51, REMOVAL, Reverse Check Sleeve.>

2) Remove the oil guide.

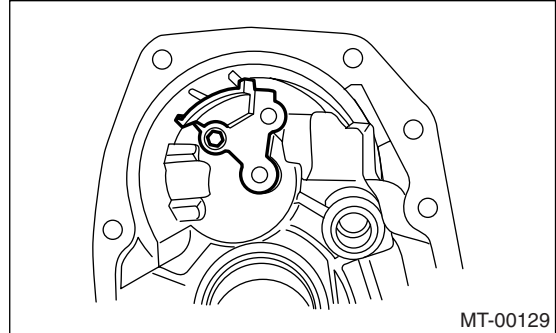

2. EXTENSION CASE

1) Remove the transfer drive gear assembly. <Ref. to 5MT-46, REMOVAL, Transfer Drive Gear.>

2) Remove the shift bracket.

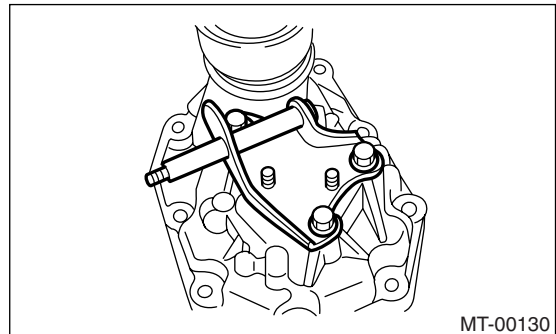

3) Remove the oil seal from extension case. <Ref. to 5MT-36, Oil Seal.>

D: ASSEMBLY

1. EXTENSION CASE

- 1) Using the ST, insert the new oil seal to extension case. <Ref. to 5MT-36, Oil Seal.>
- 2) Install the shift bracket to extension case.

Tightening torque:

24.5 N·m (2.5 kgf-m, 18.1 ft-lb)

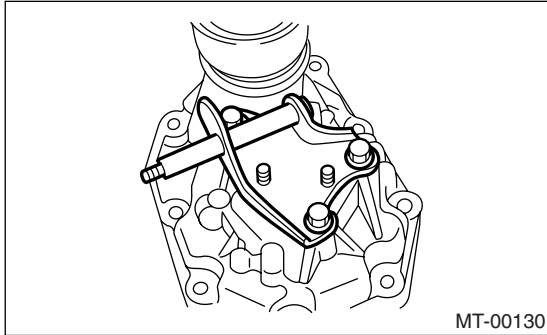

- 3) Install the transfer drive gear to extension case. <Ref. to 5MT-46, INSTALLATION, Transfer Drive Gear.>

2. TRANSFER CASE

- 1) Install the oil guide to transfer case.

Tightening torque:

6.4 N·m (0.65 kgf-m, 4.7 ft-lb)

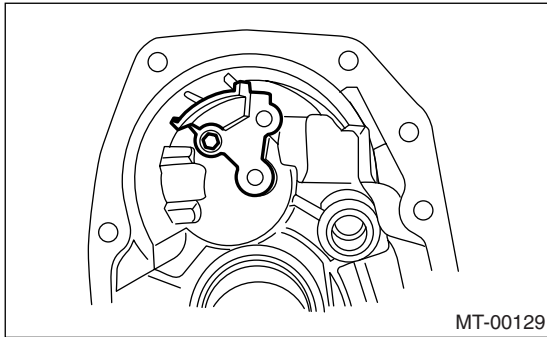

- 2) Install the reverse check sleeve assembly to transfer case. <Ref. to 5MT-51, INSTALLATION, Reverse Check Sleeve.>