

Combination Meter

INSTRUMENTATION/DRIVER INFO

3. Combination Meter

A: REMOVAL

- 1) Disconnect the ground cable from the battery.
- 2) Set the tilt steering at the lowest position.
- 3) Remove the screws and detach the meter visor.

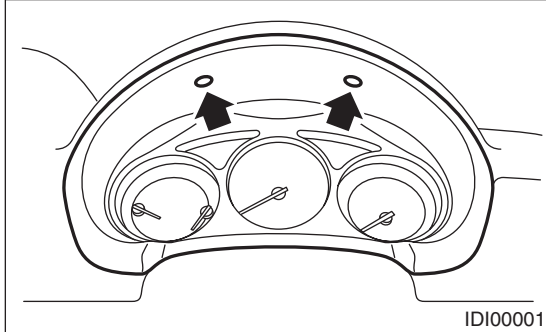

- 4) Remove the screws of combination meter and pull out the meter.

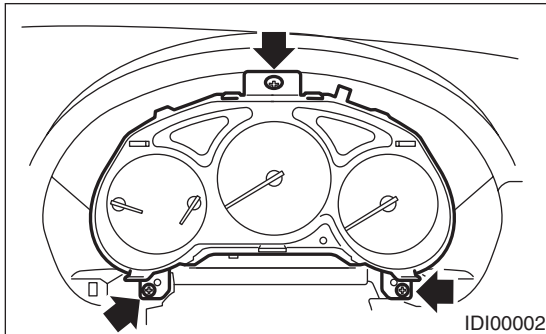

- 5) Disconnect the connector in the upper area of combination meter to remove the meter.

CAUTION:

- Be careful not to damage the meter or instrument panel.
- Be careful not to damage the meter glass.

B: INSTALLATION

Install in the reverse order of removal.

CAUTION:

- Make sure the electrical connector is connected securely.
- Make sure that each meter operates normally.

C: DISASSEMBLY

CAUTION:

Use gloves to avoid damage and getting fingerprints on the glass surface and meter surfaces.

- 1) Disengage the claw (E) to remove case (B) from back cover (A).
- 2) Disengage claw (F) to remove meter glass (D) and reflector (C) from the inner case.

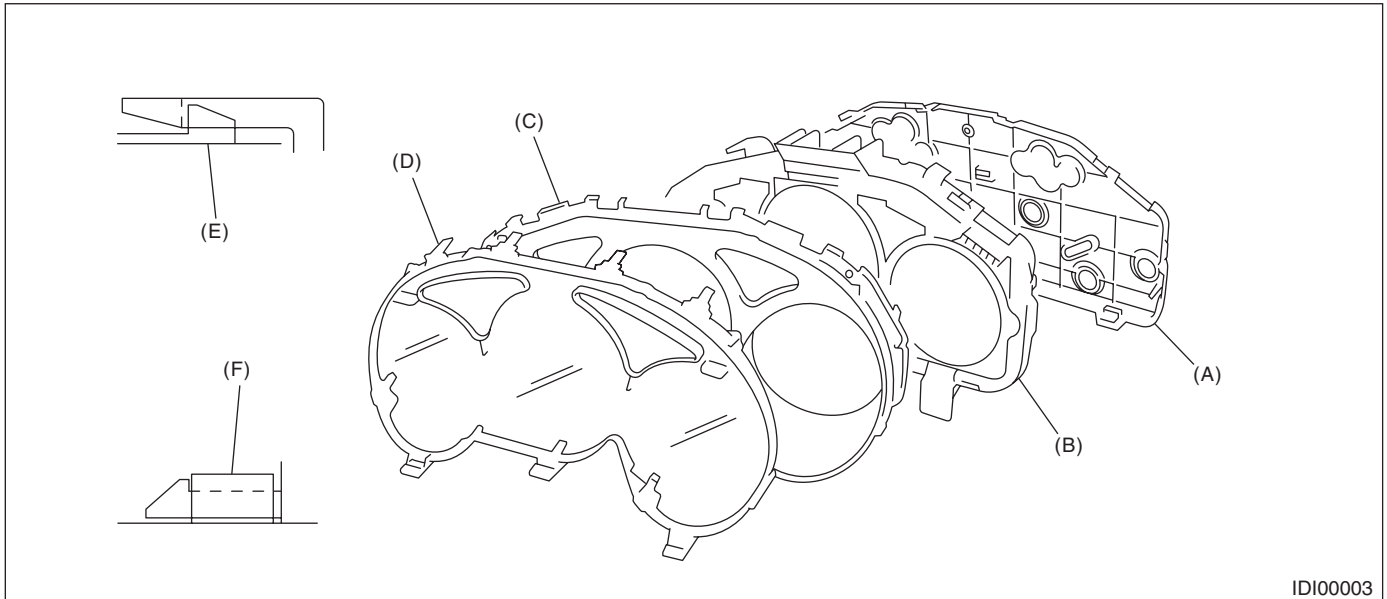

IDI00003

3) Pull up claw (A) in portion (B) of combination meter printed circuit (C) with combination pliers. Push out the speedometer (D) and tachometer (E) and water temperature gauge & fuel gauge assembly (F) using the hole (G).

4) Pull up the claw in the center of the combination meter printed circuit (C), and remove the printed circuit from case (H).

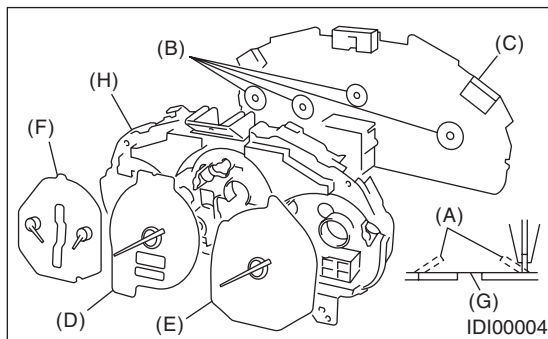

IDI00004

1. BULB REPLACEMENT

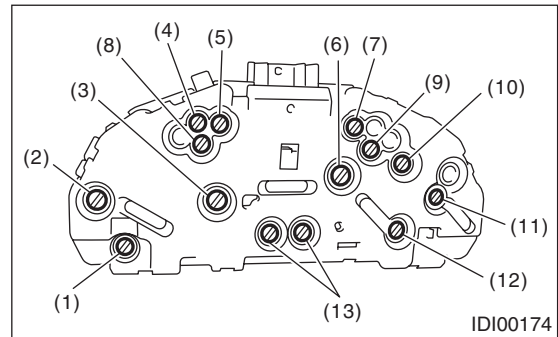

IDI00174

- (1) Charge indicator light
- (2) Tachometer
- (3) Speedometer and tachometer
- (4) HI-beam indicator light
- (5) Turn signal indicator light (Right)
- (6) Speedometer
- (7) Turn signal indicator light (Left)
- (8) Vehicle dynamics control (VDC) indicator
- (9) Brake warning light
- (10) ABS warning light
- (11) Fuel gauge
- (12) Engine coolant temperature gauge
- (13) LCD (Outside temperature display, odometer/tripmeter, and select indicator)

D: ASSEMBLY

Assemble in the reverse order of disassembly.