

Parking Brake / Brake Fluid Level Warning Light System

WIRING SYSTEM

35. Parking Brake / Brake Fluid Level Warning Light System

A: WIRING DIAGRAM

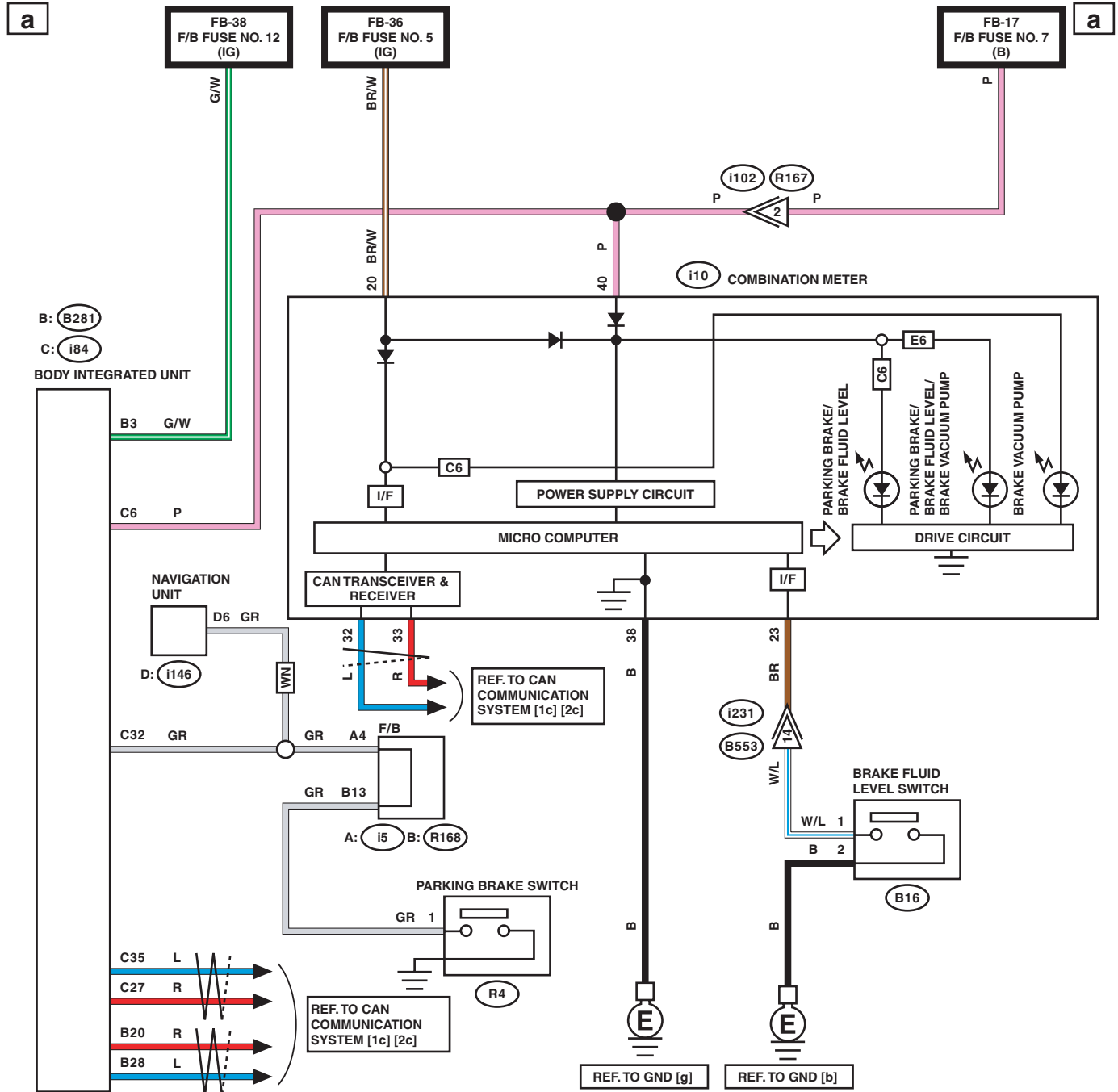

- WN** : WITH NAVIGATION
- E6** : EXCEPT FOR C6 MODEL
- C6** : C6 MODEL

WI-40880

b

b

LIST OF CONNECTORS

