

54. Starter System

A: WIRING DIAGRAM

1. NON-TURBO MODEL (WITHOUT PUSH BUTTON START)

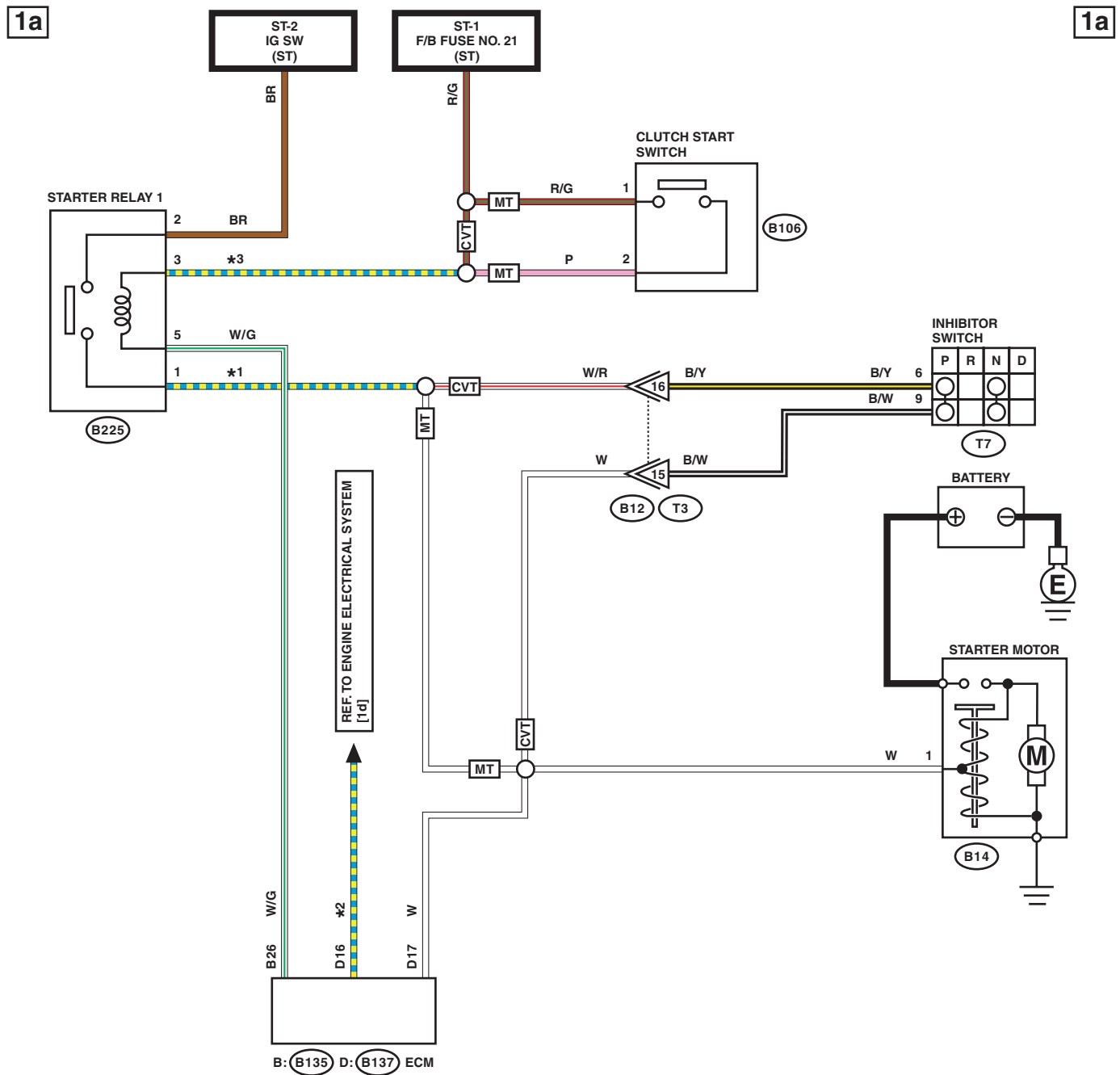

WI-40958

Starter System

WIRING SYSTEM

1b

1b

LIST OF CONNECTORS

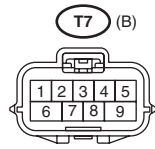
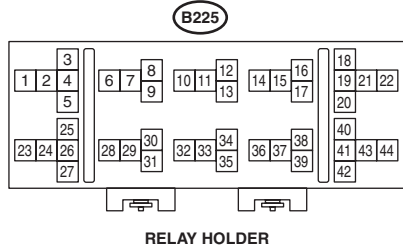
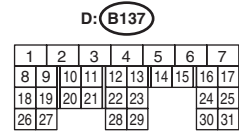
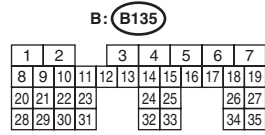
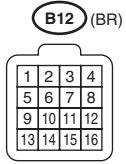

WI-39068

Starter System

WIRING SYSTEM

2. NON-TURBO MODEL (WITH PUSH BUTTON START)

2a

2a

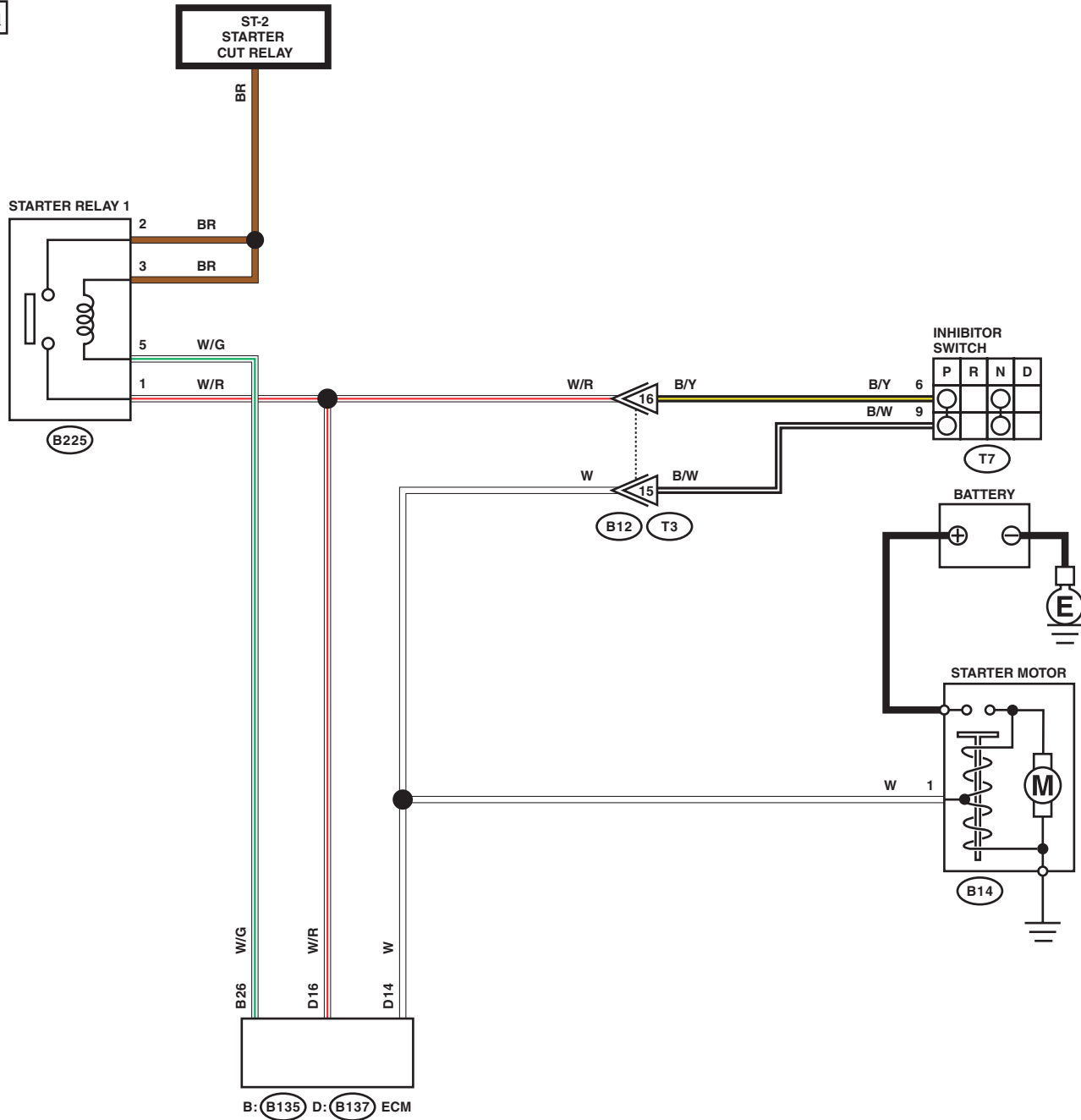

WI-40959

Starter System

WIRING SYSTEM

2b

2b

LIST OF CONNECTORS

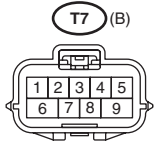
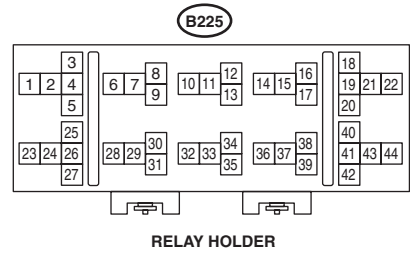
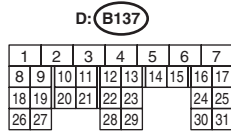
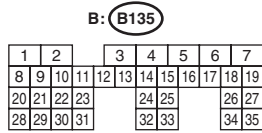
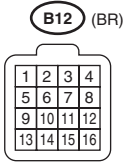

Starter System

WIRING SYSTEM

3. TURBO MODEL (WITHOUT PUSH BUTTON START)

3a

3a

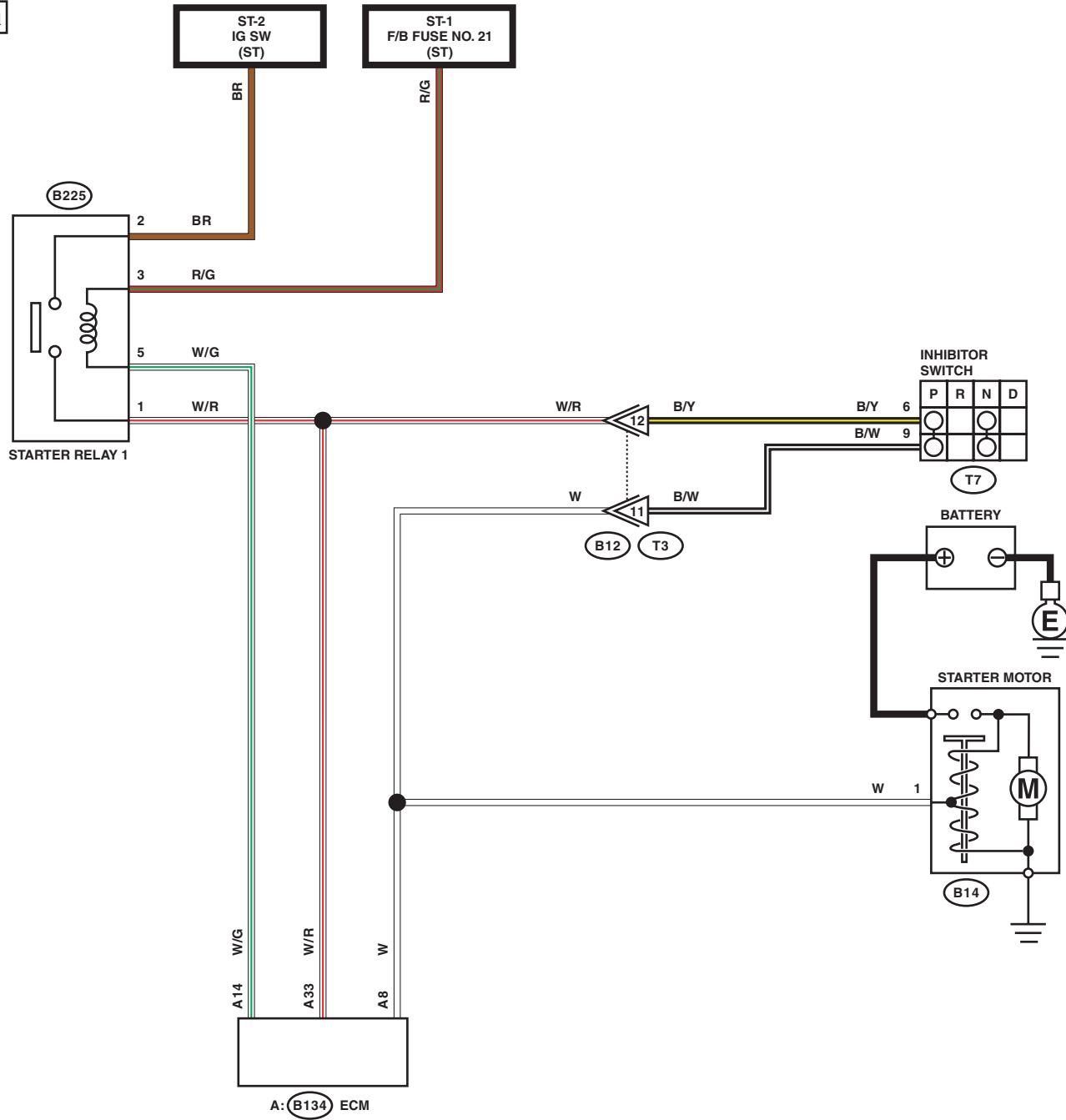

WI-40961

Starter System

WIRING SYSTEM

3b

3b

LIST OF CONNECTORS

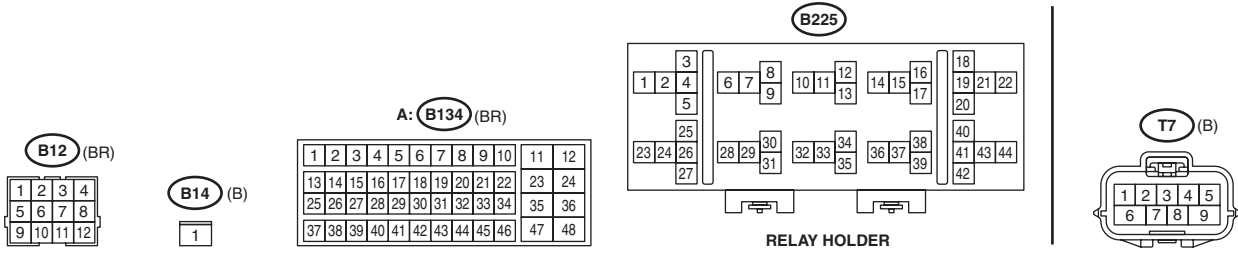

WI-40962

Starter System

WIRING SYSTEM

4. TURBO MODEL (WITH PUSH BUTTON START)

4a

4a

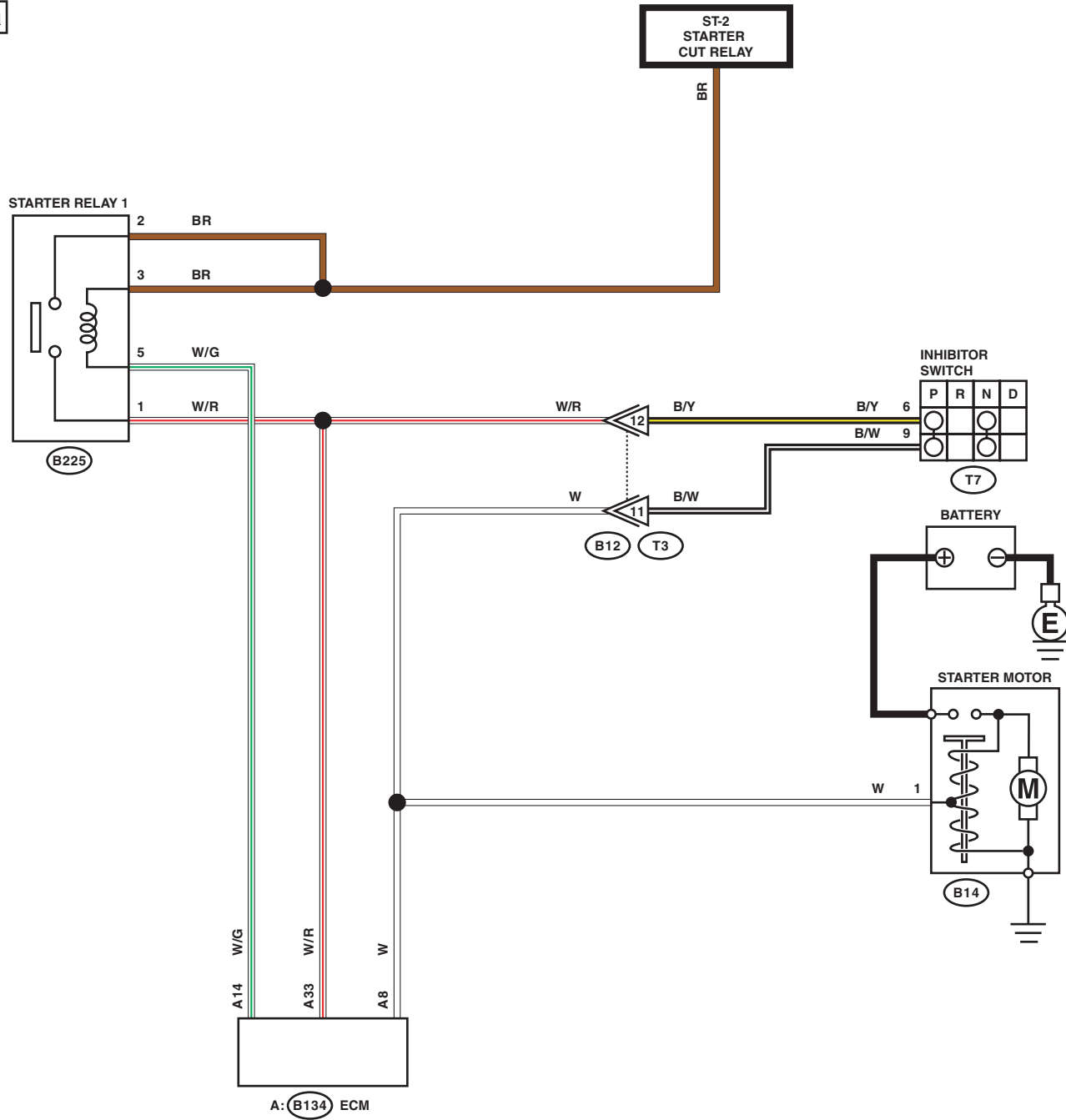

WI-40963

Starter System

WIRING SYSTEM

4b

4b

LIST OF CONNECTORS

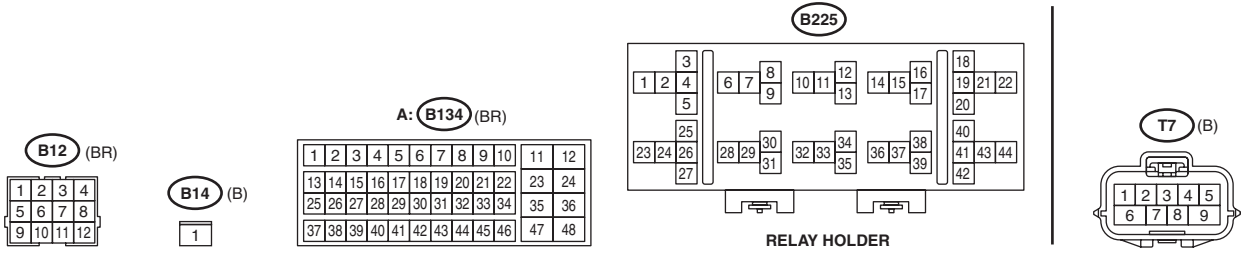

WI-40964