

BRAKES **4-4**

	Page
T DIAGNOSTICS AIRBAG	2
1. Supplemental Restraint System "Airbag"	2
2. Pre-inspection.....	2
3. Electrical Components Location.....	4
4. Schematic.....	6
5. Control Module I/O Signal.....	8
6. Diagnostics Chart for On-board Diagnosis System	11
7. Diagnostics Chart for ABS Warning Light Circuit and Diagnosis Circuit Failure.....	18
8. Diagnostics Chart with Trouble Code by ABS Warning Light.....	29
9. Select Monitor Function Mode	76
10. Diagnostics Chart with Select Monitor	78
11. General Diagnostic Table	162

1. Supplemental Restraint System "Airbag"

Airbag system wiring harness is routed near the ABS sensor, ABS control module and hydraulic control unit.

CAUTION:

- All Airbag system wiring harness and connectors are colored yellow. Do not use electrical test equipment on these circuit.
- Be careful not to damage Airbag system wiring harness when servicing the ABS sensor, ABS control module and hydraulic control unit.

2. Pre-inspection

Before performing diagnostics, check the following items which might affect ABS problems:

A: MECHANICAL INSPECTION

1. POWER SUPPLY

- 1) Measure battery voltage and specific gravity of electrolyte.

Standard voltage: 12 V, or more

Specific gravity: Above 1.260

- 2) Check the condition of the main and other fuses, and harnesses and connectors. Also check for proper grounding.

2. BRAKE FLUID

- 1) Check brake fluid level.
- 2) Check brake fluid leakage.

3. BRAKE DRAG

Check brake drag. <Ref. to 4-4 [K100].>

4. BRAKE PAD AND ROTOR

Check brake pad and rotor. <Ref. to 4-4 [K100].>

5. TIRE SPECIFICATIONS, TIRE WEAR AND AIR PRESSURE

Check tire specifications, tire wear and air pressure. <Ref. to 4-2 [S100].>, <Ref. to 4-2 [S200].>

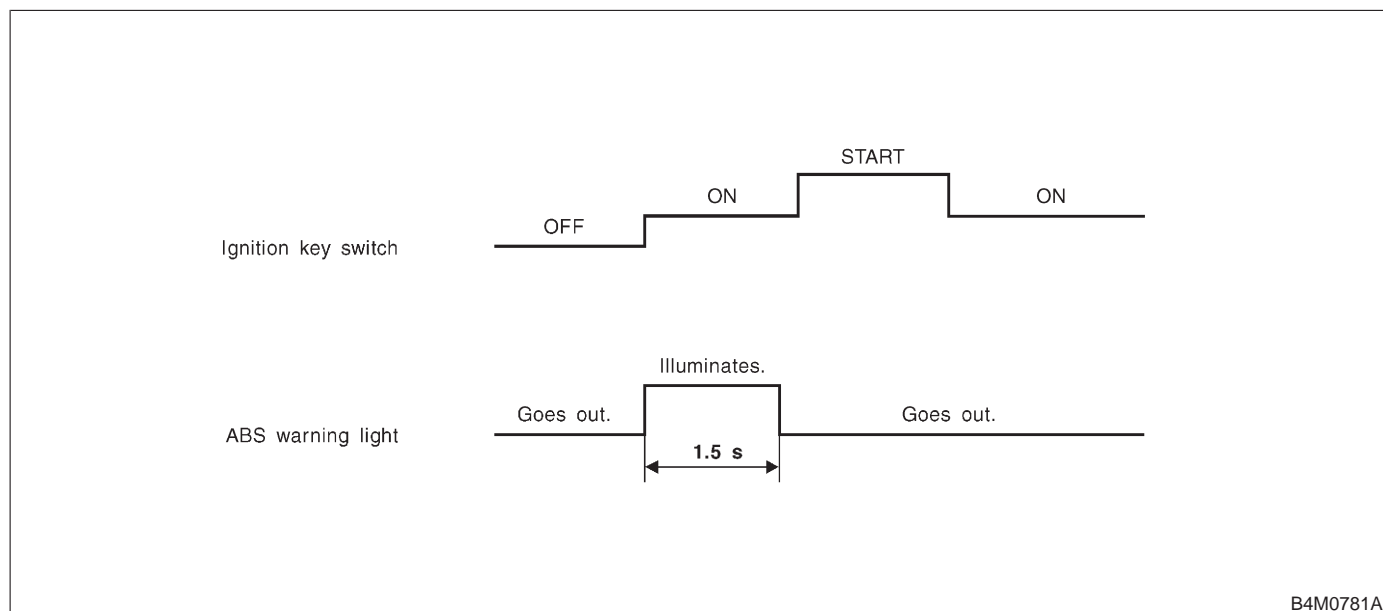
B: ELECTRICAL INSPECTION**1. WARNING LIGHT ILLUMINATION PATTERN**

1) When the ABS warning light does not illuminate in accordance with this illumination pattern, there must be an electrical malfunction.

2) When the ABS warning light remains constantly OFF, repair the ABS warning light circuit or diagnosis circuit. <Ref. to 4-4 [T7A0].>

NOTE:

Even though the ABS warning light does not go out 1.5 seconds after it illuminates, the ABS system operates normally when the warning light goes out while driving at approximately 12 km/h (7 MPH). However, the Anti-lock brakes do not work while the ABS warning light is illuminated.

3. Electrical Components Location

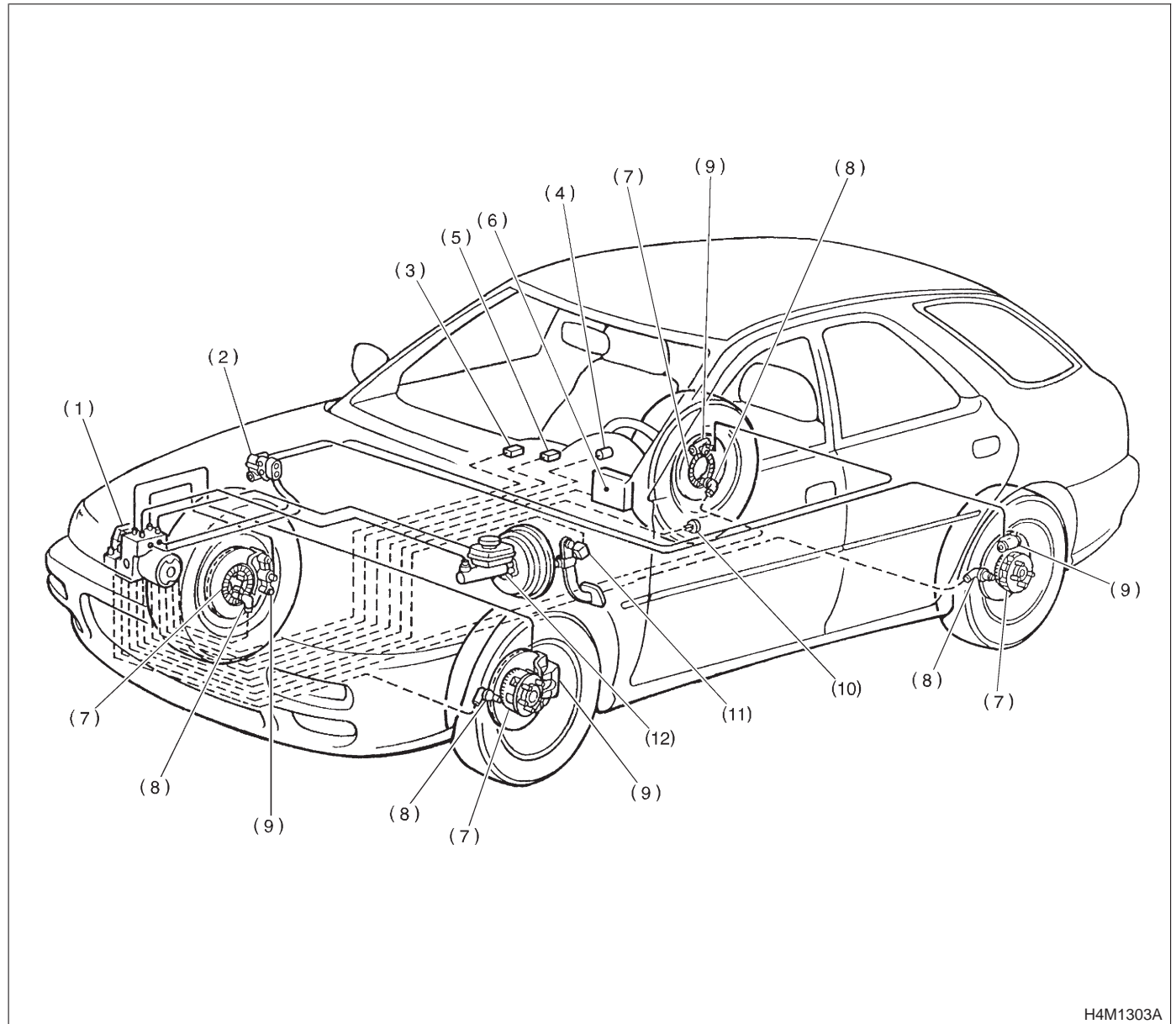

H4M1303A

- (1) ABS control module and hydraulic control unit (ABSCM&H/U)
- (2) Proportioning valve
- (3) Diagnosis connector
- (4) ABS warning light

- (5) Data link connector (for Subaru select monitor)
- (6) Transmission control module (only AT vehicle)
- (7) Tone wheel

- (8) ABS sensor
- (9) Wheel cylinder
- (10) G sensor
- (11) Brake switch
- (12) Master cylinder

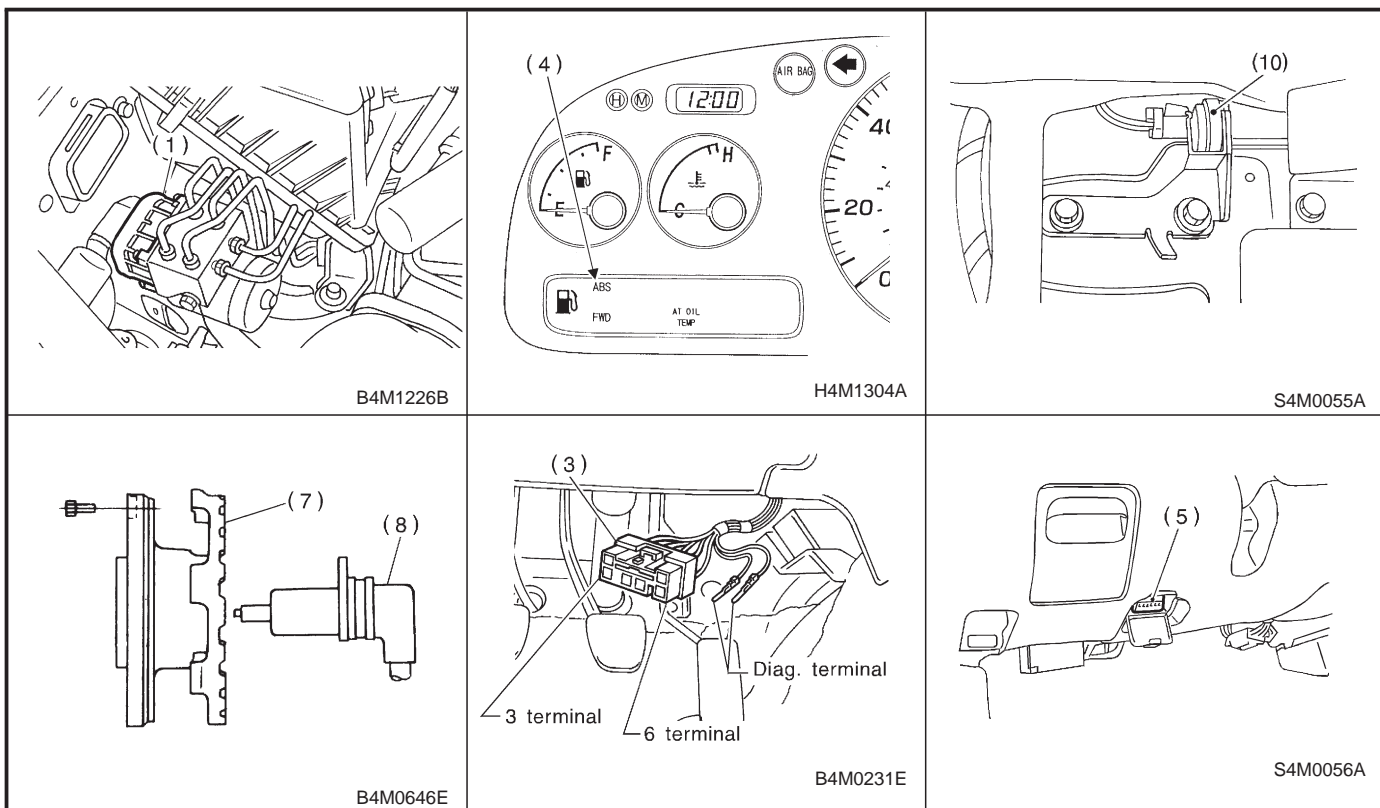

4. Schematic

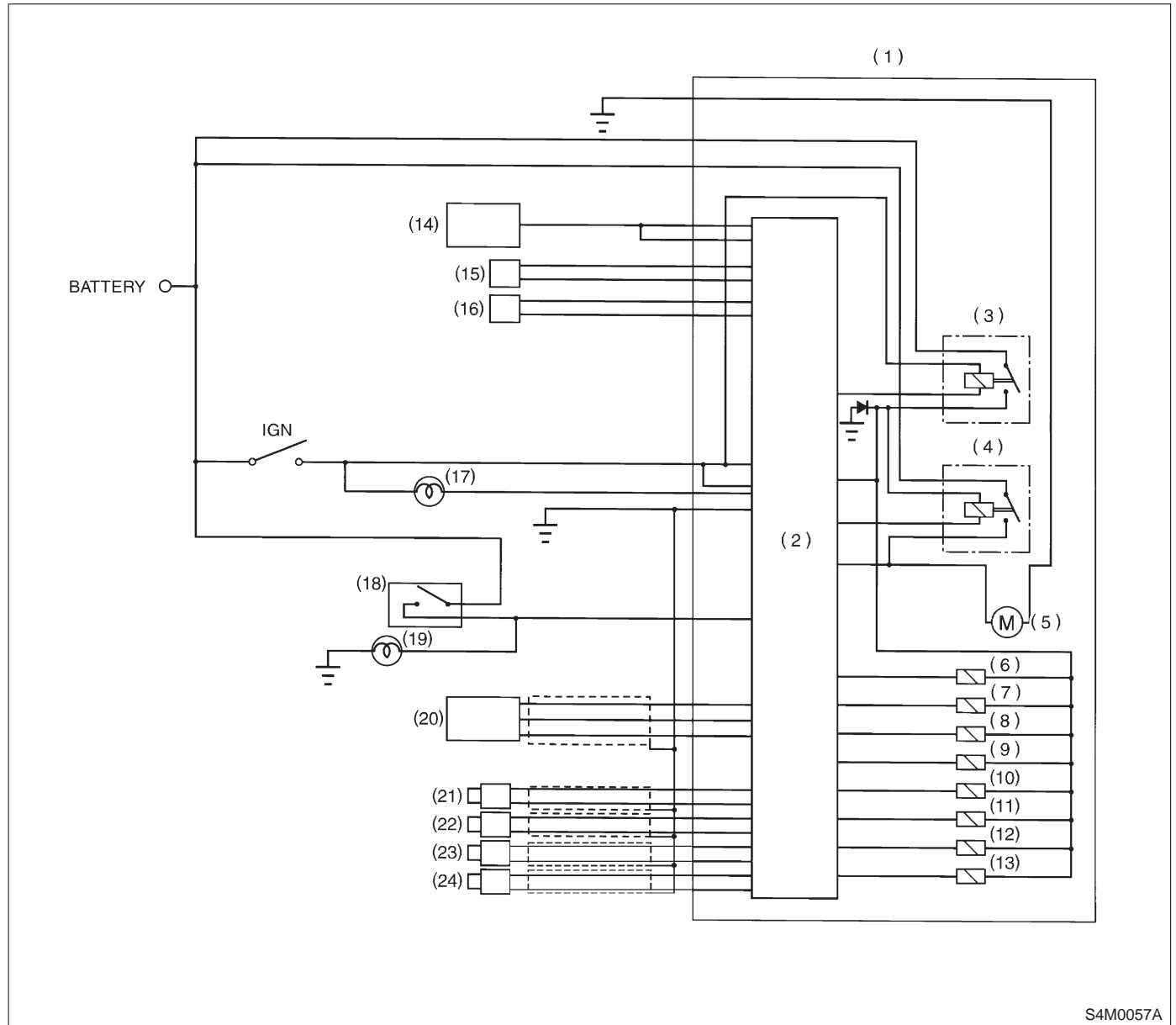

- | | | |
|---|--|-----------------------------|
| (1) ABS control module and hydraulic control unit (ABSCM&H/U) | (9) Front right outlet solenoid valve | (17) ABS warning light |
| (2) ABS control module area | (10) Rear left inlet solenoid valve | (18) Stop light switch |
| (3) Valve relay | (11) Rear left outlet solenoid valve | (19) Stop light |
| (4) Motor relay | (12) Rear right inlet solenoid valve | (20) G sensor |
| (5) Motor | (13) Rear right outlet solenoid valve | (21) Front left ABS sensor |
| (6) Front left inlet solenoid valve | (14) Transmission control module (only AT model) | (22) Front right ABS sensor |
| (7) Front left outlet solenoid valve | (15) Diagnosis connector | (23) Rear left ABS sensor |
| (8) Front right inlet solenoid valve | (16) Data link connector | (24) Rear right ABS sensor |

MEMO:

5. Control Module I/O Signal

A: I/O SIGNAL VOLTAGE

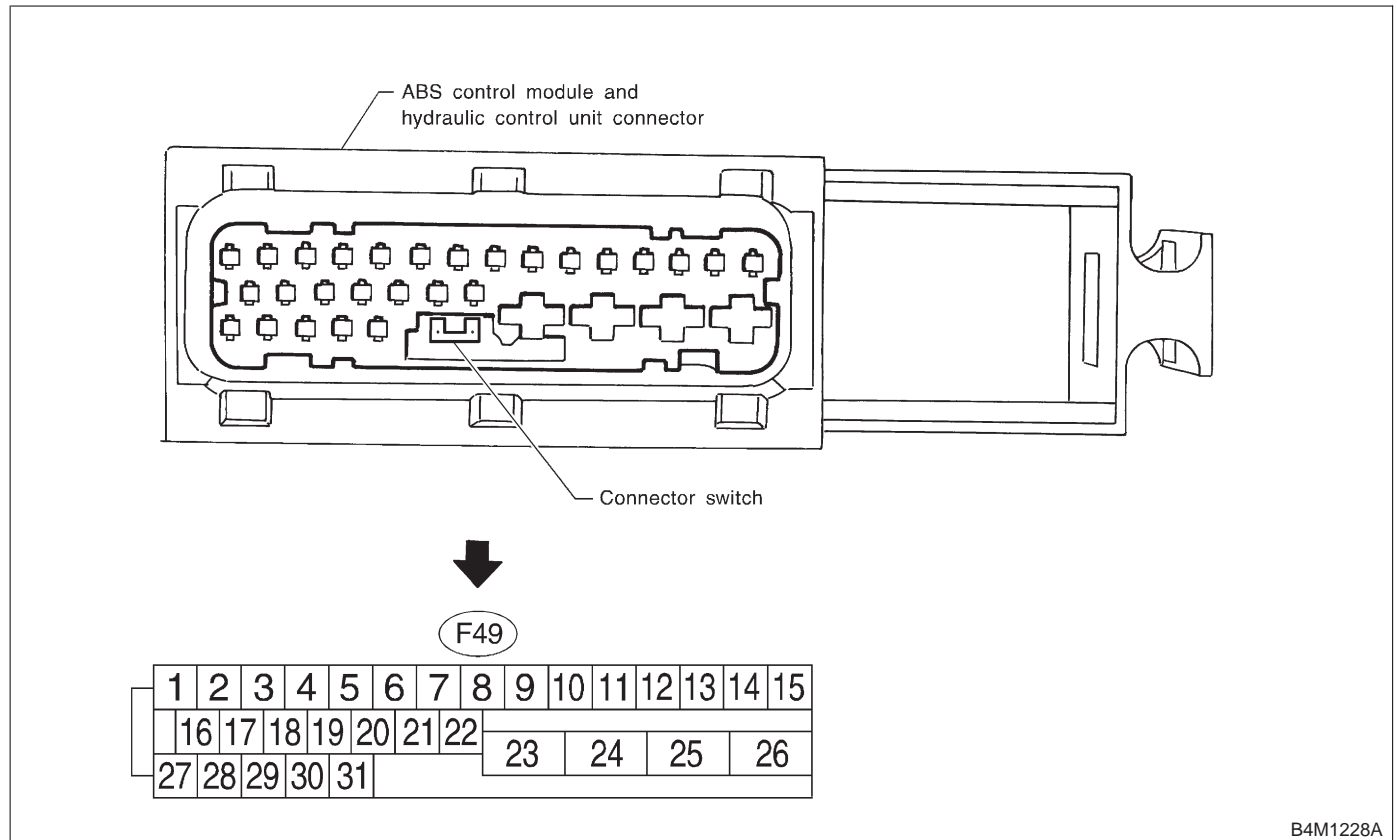

NOTE:

- The terminal numbers in the ABS control module and hydraulic control unit connector are as shown in the figure.
- When the connector is removed from the ABSCM&H/U, the connector switch closes the circuit between terminal No. 21 and No. 23. The ABS warning light illuminates.

Contents		Terminal No. (+)-(-)	Input/Output signal
			Measured value and measuring conditions
ABS sensor*2 (Wheel speed sensor)	Front left wheel	9—10	0.12 — 1 V (When it is 20 Hz.)
	Front right wheel	11—12	
	Rear left wheel	7—8	
	Rear right wheel	14—15	
Valve relay power supply*1		24—23	10 — 15 V when ignition switch is ON.
Motor relay power supply*1		25—23	10 — 15 V when ignition switch is ON.
G sensor*2 (AWD model only)	power supply	30—28	4.75 — 5.25 V
	ground	28	—
	output	6—28	2.3±0.2 V when vehicle is in horizontal position.
Stop light switch*1		2—23	Less than 1.5 V when the stop light is OFF and, 10 — 15 V when the stop light is ON.
ABS warning light*2		21—23	Less than 1.5 V during 1.5 seconds when ignition switch is ON, and 10 — 15 V after 1.5 seconds.
AT ABS signal*2 (AT model only)		31—23	Less than 1.5 V when the ABS control does not operate still and more than 5.5 V when ABS operates.
ABS operation signal monitor*2		3—23	Less than 1.5 V when the ABS control does not operate still and more than 5.5 V when ABS operates.
Select monitor*2	Data is received.	20—23	Less than 1.5 V when no data is received.
	Data is sent.	5—23	4.75 — 5.25 V when no data is sent.
ABS diagnosis connector*2	Terminal No. 3	29—23	10 — 15 V when ignition switch is ON.
	Terminal No. 6	4—23	10 — 15 V when ignition switch is ON.
Power supply*1		1—23	10 — 15 V when ignition switch is ON.
Grounding line		23	—
Grounding line		26	—

*1: Measure the I/O signal voltage after removing the connector from the ABSCM&H/U terminal.

*2: Measure the I/O signal voltage at connector (F2) or (F55).

B: I/O SIGNAL DIAGRAM

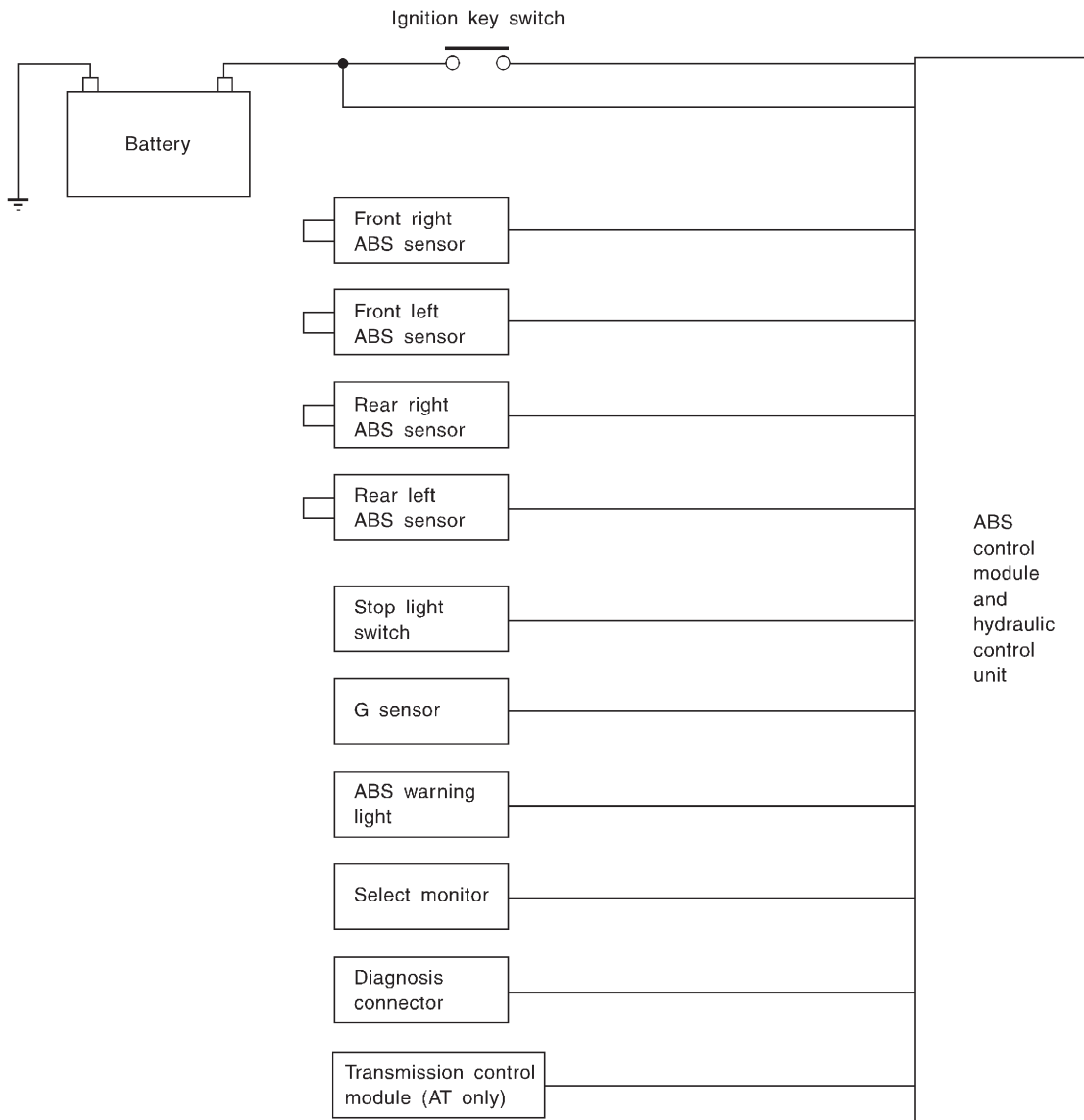

6. Diagnostics Chart for On-board Diagnosis System

A: BASIC DIAGNOSTICS PROCEDURE

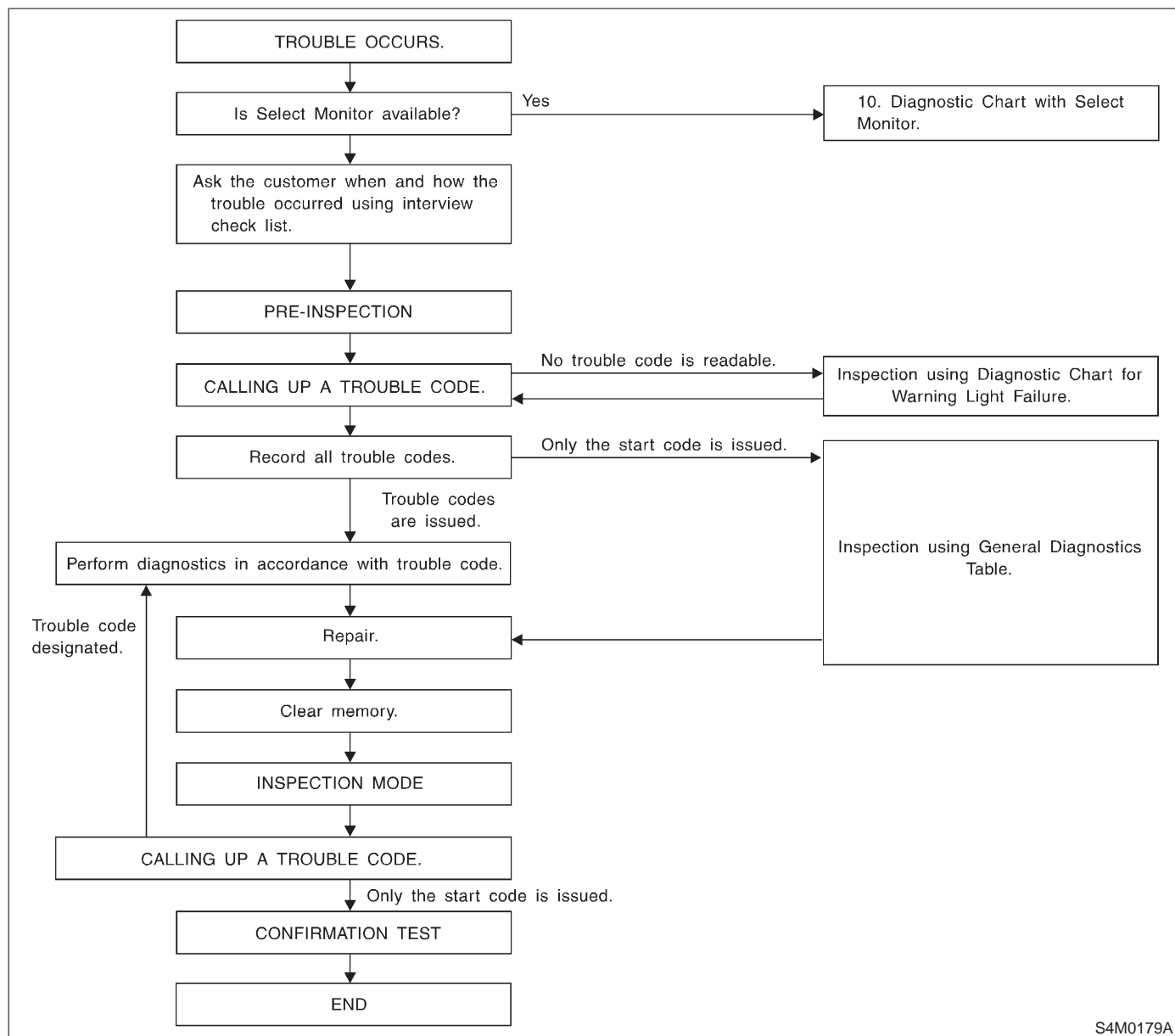

S4M0179A

CAUTION:

Remove foreign matter (dust, water, etc.) from the ABSCM&H/U connector during removal and installation.

NOTE:

- To check harness for broken wires or short circuits, shake it while holding it or the connector.
- When ABS warning light illuminates, read and record trouble code indicated by ABS warning light.

B: CHECK LIST FOR INTERVIEW

Check The Following Items About The Vehicle's State.

1. THE STATE OF THE ABS WARNING LIGHT

ABS warning light comes on.	<input type="checkbox"/> Always <input type="checkbox"/> Sometimes <input type="checkbox"/> Only once <input type="checkbox"/> Does not come on ● When / how long does it come on?:		
Ignition key position	<input type="checkbox"/> LOCK <input type="checkbox"/> ACC <input type="checkbox"/> ON (before starting engine) <input type="checkbox"/> START <input type="checkbox"/> On after starting (Engine is running) <input type="checkbox"/> On after starting (Engine is stop)		
Timing	<input type="checkbox"/> Immediately after ignition is ON. <input type="checkbox"/> Immediately after ignition starts.		
	<input type="checkbox"/> When advancing	km/h to	km/h
		MPH to	MPH
	<input type="checkbox"/> While traveling at a constant speed	km/h	MPH
	<input type="checkbox"/> When decelerating	km/h to	km/h
		MPH to	MPH
	<input type="checkbox"/> When turning to right	Steering angle :	deg
		Steering time :	sec
	<input type="checkbox"/> When turning to left	Steering angle :	deg
		Steering time :	sec
<input type="checkbox"/> When moving other electrical parts ● Parts name : ● Operating condition :			

2. SYMPTOMS

ABS operating condition	<input type="checkbox"/> Performs no work.		
	<input type="checkbox"/> Operates only when abruptly applying brakes.	Vehicle speed :	km/h
			MPH
	● How to step on brake pedal :		
	a) Operating time :		sec
	b) Operating noise : <input type="checkbox"/> Produce / <input type="checkbox"/> Does not produce		
	● What kind of noise?	<input type="checkbox"/> Knock <input type="checkbox"/> Gong gong <input type="checkbox"/> Bong <input type="checkbox"/> Buzz <input type="checkbox"/> Gong gong buzz <input type="checkbox"/> Others :	
	c) Reaction force of brake pedal		
		<input type="checkbox"/> Stick <input type="checkbox"/> Press down once with a clunk <input type="checkbox"/> Press and released <input type="checkbox"/> Others :	

Behavior of vehicle	a) Directional stability cannot be obtained or steering arm refuses to work when applying brakes : <input type="checkbox"/> Yes / <input type="checkbox"/> No	
	● When :	<input type="checkbox"/> Vehicle turns to right <input type="checkbox"/> Vehicle turns to left <input type="checkbox"/> Spins <input type="checkbox"/> Others :
	b) Directional stability cannot be obtained or steering arm refuses to work when accelerating : <input type="checkbox"/> Yes / <input type="checkbox"/> No	
	● When :	<input type="checkbox"/> Vehicle turns to right <input type="checkbox"/> Vehicle turns to left <input type="checkbox"/> Spins <input type="checkbox"/> Others :
	c) Brakes are out of order : <input type="checkbox"/> Yes / <input type="checkbox"/> No	
	● What :	<input type="checkbox"/> Braking distance is long <input type="checkbox"/> Brakes lock or drag <input type="checkbox"/> Pedal stroke is long <input type="checkbox"/> Pedal sticks <input type="checkbox"/> Others :
	d) Poor acceleration : <input type="checkbox"/> Yes / <input type="checkbox"/> No	
	● What :	<input type="checkbox"/> Fails to accelerate <input type="checkbox"/> Engine stalls <input type="checkbox"/> Others :
	e) Occurrence of vibration : <input type="checkbox"/> Yes / <input type="checkbox"/> No	
	● Where	
	● What kind :	
	f) Occurrence of abnormal noise : <input type="checkbox"/> Yes / <input type="checkbox"/> No	
	● Where	
	● What kind :	
g) Occurrence of other phenomena : <input type="checkbox"/> Yes / <input type="checkbox"/> No		
● What kind :		

3. CONDITIONS UNDER WHICH TROUBLE OCCURS

Environment	a) Weather	<input type="checkbox"/> Fine <input type="checkbox"/> Cloudy <input type="checkbox"/> Rainy <input type="checkbox"/> Snowy <input type="checkbox"/> Various/Others :
	b) Ambient temperature	°F (°C)
	c) Road	<input type="checkbox"/> Urban area <input type="checkbox"/> Suburbs <input type="checkbox"/> Highway <input type="checkbox"/> General road <input type="checkbox"/> Ascending slope <input type="checkbox"/> Descending slope <input type="checkbox"/> Paved road <input type="checkbox"/> Gravel road <input type="checkbox"/> Muddy road <input type="checkbox"/> Sandy place <input type="checkbox"/> Others :
	d) Road surface	<input type="checkbox"/> Dry <input type="checkbox"/> Wet <input type="checkbox"/> New-fallen snow <input type="checkbox"/> Compressed snow <input type="checkbox"/> Frozen slope <input type="checkbox"/> Others :

Condition	a) Brakes	Deceleration : g		
		<input type="checkbox"/> Continuous / <input type="checkbox"/> Intermittent		
	b) Accelerator	Acceleration : g		
		<input type="checkbox"/> Continuous / <input type="checkbox"/> Intermittent		
	c) Vehicle speed		km/h	MPH
			<input type="checkbox"/> Advancing	
			<input type="checkbox"/> Accelerating	
			<input type="checkbox"/> Reducing speed	
			<input type="checkbox"/> Low speed	
	d) Tire inflation pressure		<input type="checkbox"/> Turning	
			<input type="checkbox"/> Others :	
			Front RH tire :	kPa
			Front LH tire :	kPa
	e) Degree of wear		Rear RH tire :	kPa
			Rear LH tire :	kPa
			Front RH tire :	
			Front LH tire :	
		Rear RH tire :		
		Rear LH tire :		
	f) Genuine parts are used. : <input type="checkbox"/> Yes / <input type="checkbox"/> No			
g) Chain is passed around tires. : <input type="checkbox"/> Yes / <input type="checkbox"/> No				
h) T tire is used. : <input type="checkbox"/> Yes / <input type="checkbox"/> No				
i) Condition of suspension alignment :				
j) Loading state :				
k) Repair parts are used. : <input type="checkbox"/> Yes / <input type="checkbox"/> No				
● What :				
l) Others :				

C: INSPECTION MODE

Reproduce the condition under which the problem has occurred as much as possible.

Drive the vehicle at a speed more than 40 km/h (25 MPH) for at least one minute.

D: TROUBLE CODES

When on-board diagnosis of the ABS control module detects a problem, the information (up to a maximum of three) will be stored in the EEPROM as a trouble code. When there are more than three, the most recent three will be stored. (Stored codes will stay in memory until they are cleared.)

1. CALLING UP A TROUBLE CODE

1) Take out diagnosis connector from side of driver's seat heater unit.

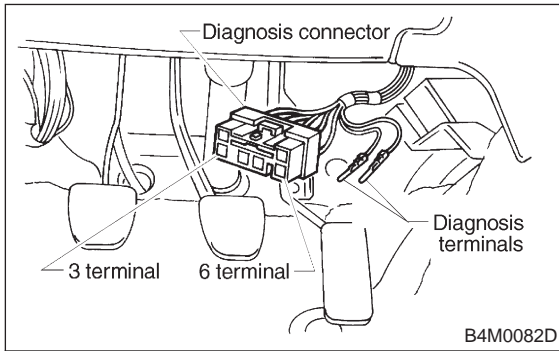

- 2) Turn ignition switch OFF.
- 3) Connect diagnosis connector terminal 6 to diagnosis terminal.
- 4) Turn ignition switch ON.
- 5) ABS warning light is set in the diagnostic mode and blinks to identify trouble code.

6) After the start code (11) is shown, the trouble codes will be shown in order of the last information first. These repeat for a maximum of 5 minutes.

NOTE:

When there are no trouble codes in memory, only the start code (11) is shown.

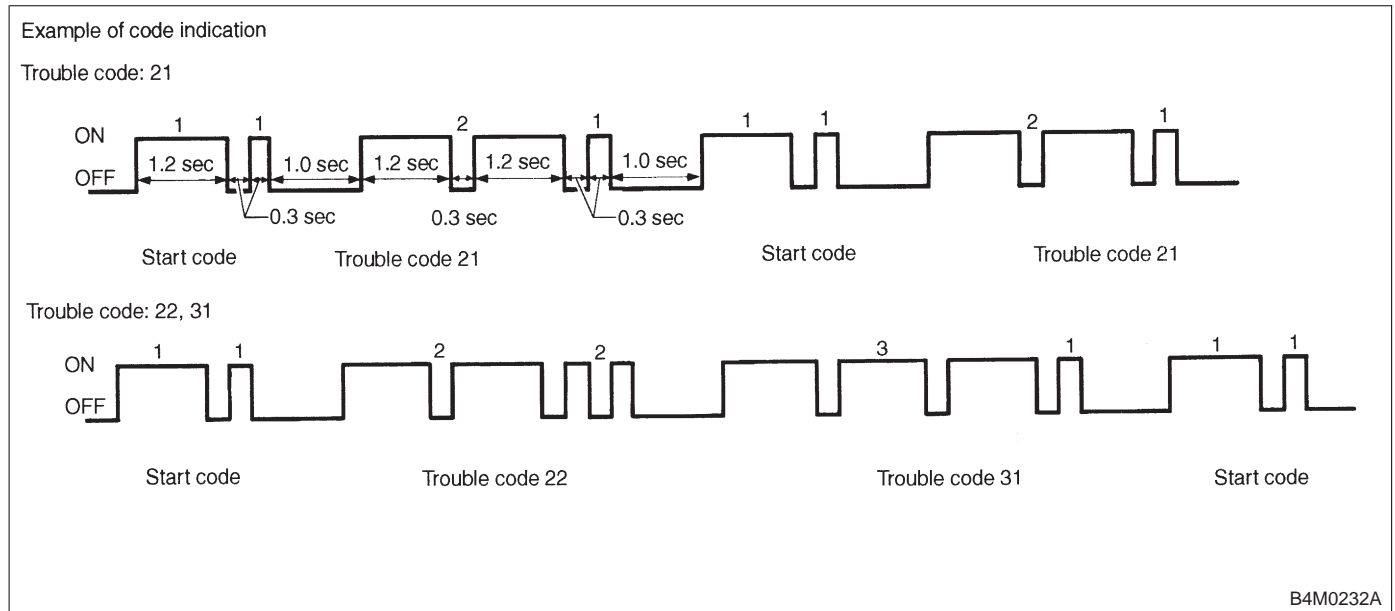

2. CLEARING MEMORY

1) After calling up a trouble code, disconnect diagnosis connector terminal 6 from diagnosis terminal.

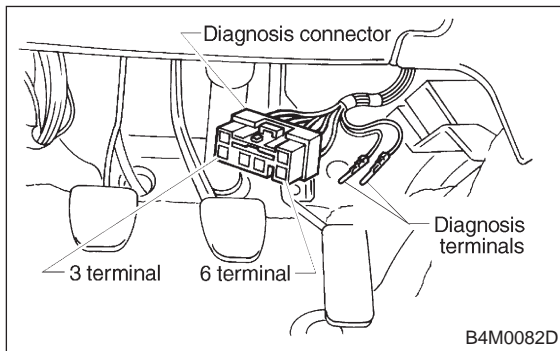

2) Repeat 3 times within approx. 12 seconds; connecting and disconnecting terminal 6 and diagnosis terminal for at least 0.2 seconds each time.

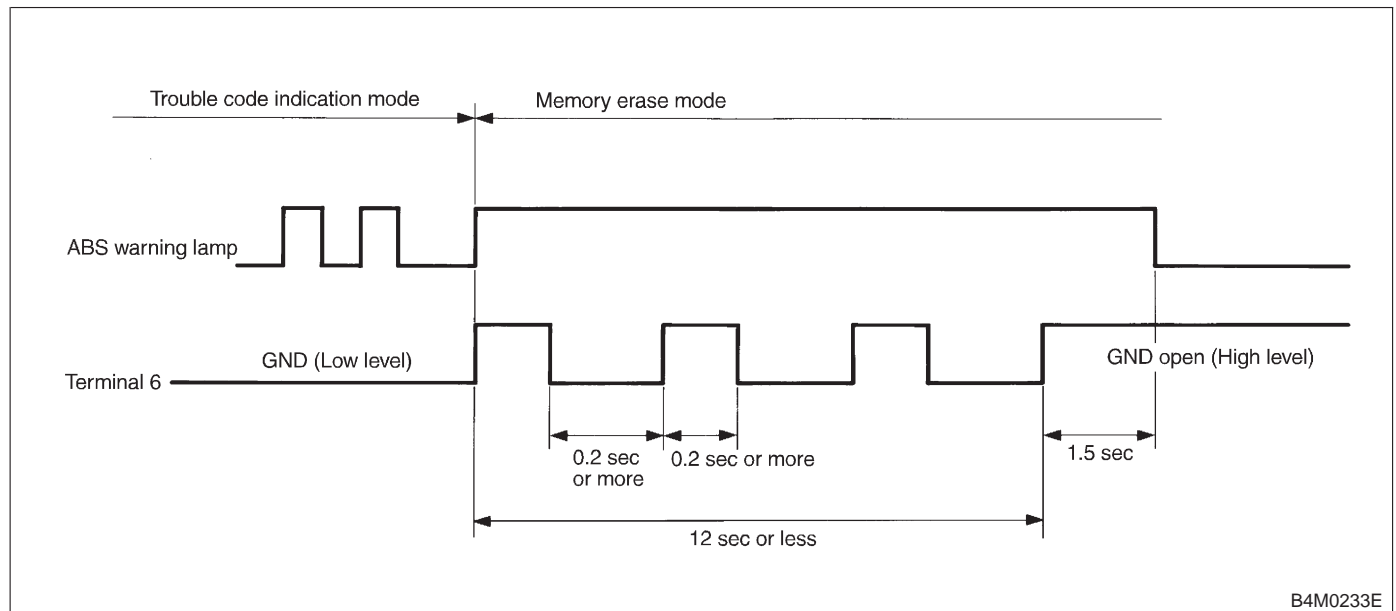

NOTE:
 After diagnostics is completed, make sure to clear memory. Make sure only start code (11) is shown after memory is cleared.

MEMO:

7. Diagnostics Chart for ABS Warning Light Circuit and Diagnosis Circuit Failure

A: ABS WARNING LIGHT DOES NOT COME ON.

DIAGNOSIS:

- ABS warning light circuit is open or shorted.

TROUBLE SYMPTOM:

- When ignition switch is turned ON (engine OFF), ABS warning light does not come on.

WIRING DIAGRAM:

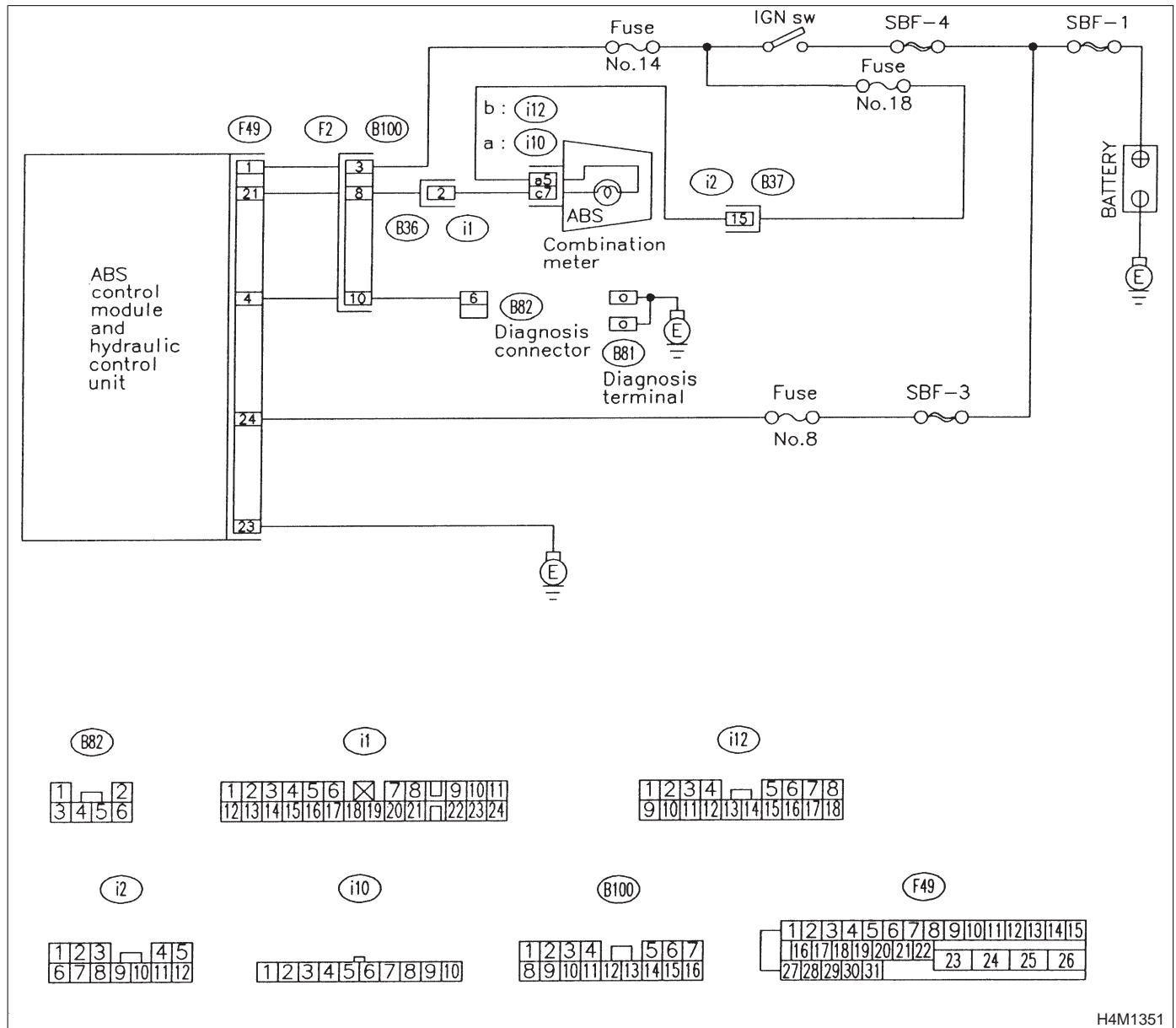

7A1 : CHECK IF OTHER WARNING LIGHTS TURN ON.

Turn ignition switch to ON (engine OFF).

- CHECK** : *Do other warning lights turn on?*
- YES** : Go to step **7A2**.
- NO** : Repair combination meter.

7A2 : CHECK ABS WARNING LIGHT BULB.

- 1) Turn ignition switch to OFF.
- 2) Remove combination meter.
- 3) Remove ABS warning light bulb from combination meter.

- CHECK** : *Is ABS warning light bulb OK?*
- YES** : Go to step **7A3**.
- NO** : Replace ABS warning light bulb.

7A3 : CHECK BATTERY SHORT OF ABS WARNING LIGHT HARNESS.

- 1) Disconnect connector (B100) from connector (F2).
- 2) Measure voltage between connector (B100) and chassis ground.

Connector & terminal
(B100) No. 8 (+) — Chassis ground (-):

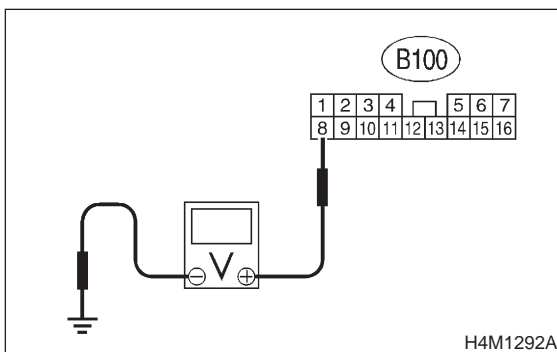

- CHECK** : *Is the voltage less than 3 V?*
- YES** : Go to step **7A4**.
- NO** : Repair warning light harness.

7A4 : CHECK BATTERY SHORT OF ABS WARNING LIGHT HARNESS.

- 1) Turn ignition switch to ON.
- 2) Measure voltage between connector (B100) and chassis ground.

Connector & terminal
(B100) No. 8 (+) — Chassis ground (-):

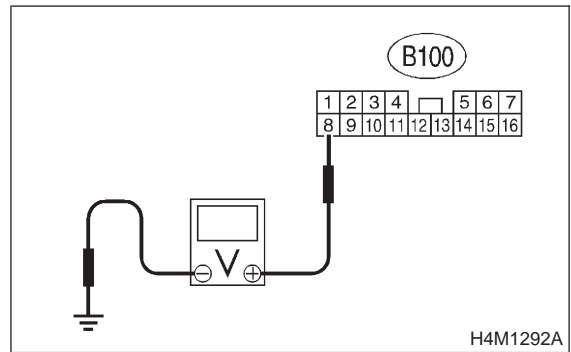

- CHECK** : *Is voltage less than 3 V?*
- YES** : Go to step **7A5**.
- NO** : Repair warning light harness.

7A5 : CHECK WIRING HARNESS.

- 1) Turn ignition switch to OFF.
- 2) Install ABS warning light bulb from combination meter.
- 3) Install combination meter.
- 4) Turn ignition switch to ON.
- 5) Measure voltage between connector (B100) and chassis ground.

Connector & terminal
(B100) No. 8 (+) — Chassis ground (-):

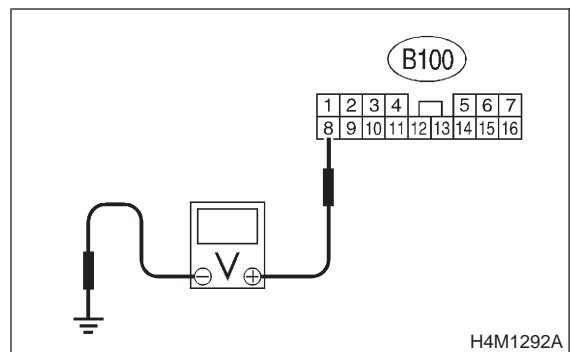

- CHECK** : *Is voltage between 10 V and 15 V?*
- YES** : Go to step **7A6**.
- NO** : Repair wiring harness.

7A6 : CHECK BATTERY SHORT OF ABS WARNING LIGHT HARNESS.

- 1) Turn ignition switch to OFF.
- 2) Measure voltage between connector (F2) and chassis ground.

Connector & terminal
(F2) No. 8 (+) — Chassis ground (-):

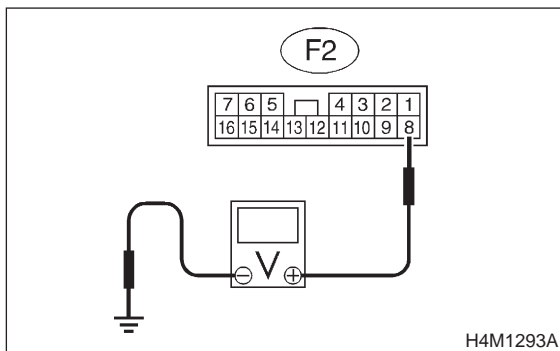

- CHECK** : Is the voltage less than 3 V?
- YES** : Go to step 7A7.
- NO** : Repair wiring harness.

7A7 : CHECK BATTERY SHORT OF ABS WARNING LIGHT HARNESS.

- 1) Turn ignition switch to ON.
- 2) Measure voltage between connector (F2) and chassis ground.

Connector & terminal
(F2) No. 8 (+) — Chassis ground (-):

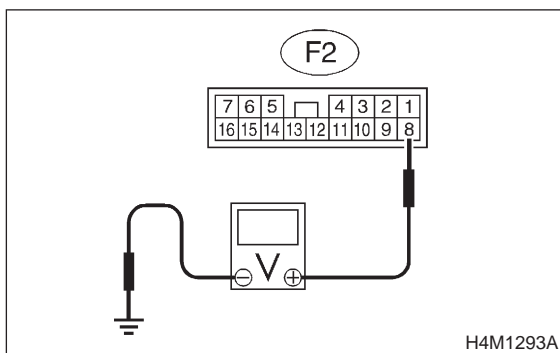

- CHECK** : Is voltage less than 3 V?
- YES** : Go to step 7A8.
- NO** : Repair wiring harness.

7A8 : CHECK GROUND CIRCUIT OF ABSCM&H/U.

Measure resistance between ABSCM&H/U and chassis ground.

Connector & terminal
(F49) No. 23 — GND:

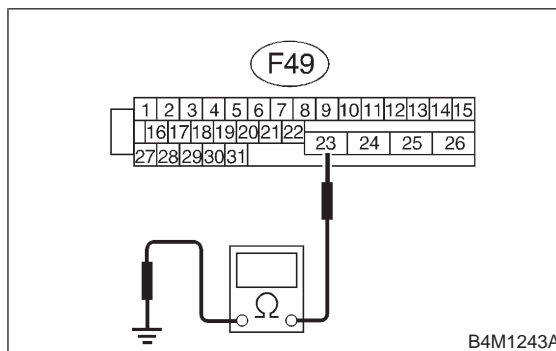

- CHECK** : Is the resistance less than 0.5 Ω?
- YES** : Go to step 7A9.
- NO** : Repair ABSCM&H/U ground harness.

7A9 : CHECK WIRING HARNESS.

Measure resistance between connector (F2) and chassis ground.

Connector & terminal
(F2) No. 8 — Chassis ground:

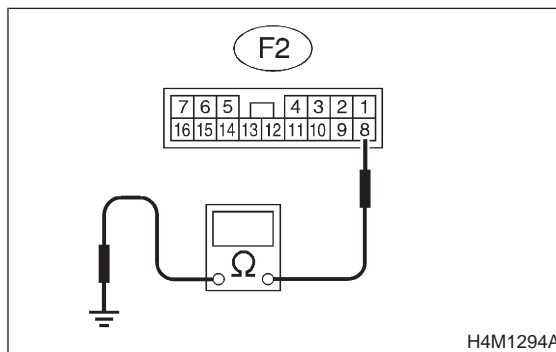

- CHECK** : Is the resistance less than 0.5 Ω?
- YES** : Go to step 7A10.
- NO** : Repair harness/connector.

7A10 : CHECK POOR CONTACT IN CONNECTORS.

Turn ignition switch to OFF.

CHECK : *Is there poor contact in connectors between combination meter and ABSCM&H/U? <Ref. to FOREWORD [T3C1].>*

YES : Repair connector.

NO : Replace ABSCM&H/U.

B: ABS WARNING LIGHT DOES NOT GO OFF.

DIAGNOSIS:

- ABS warning light circuit is open or shorted.

TROUBLE SYMPTOM:

- When starting the engine and while ABS warning light is kept ON.

WIRING DIAGRAM:

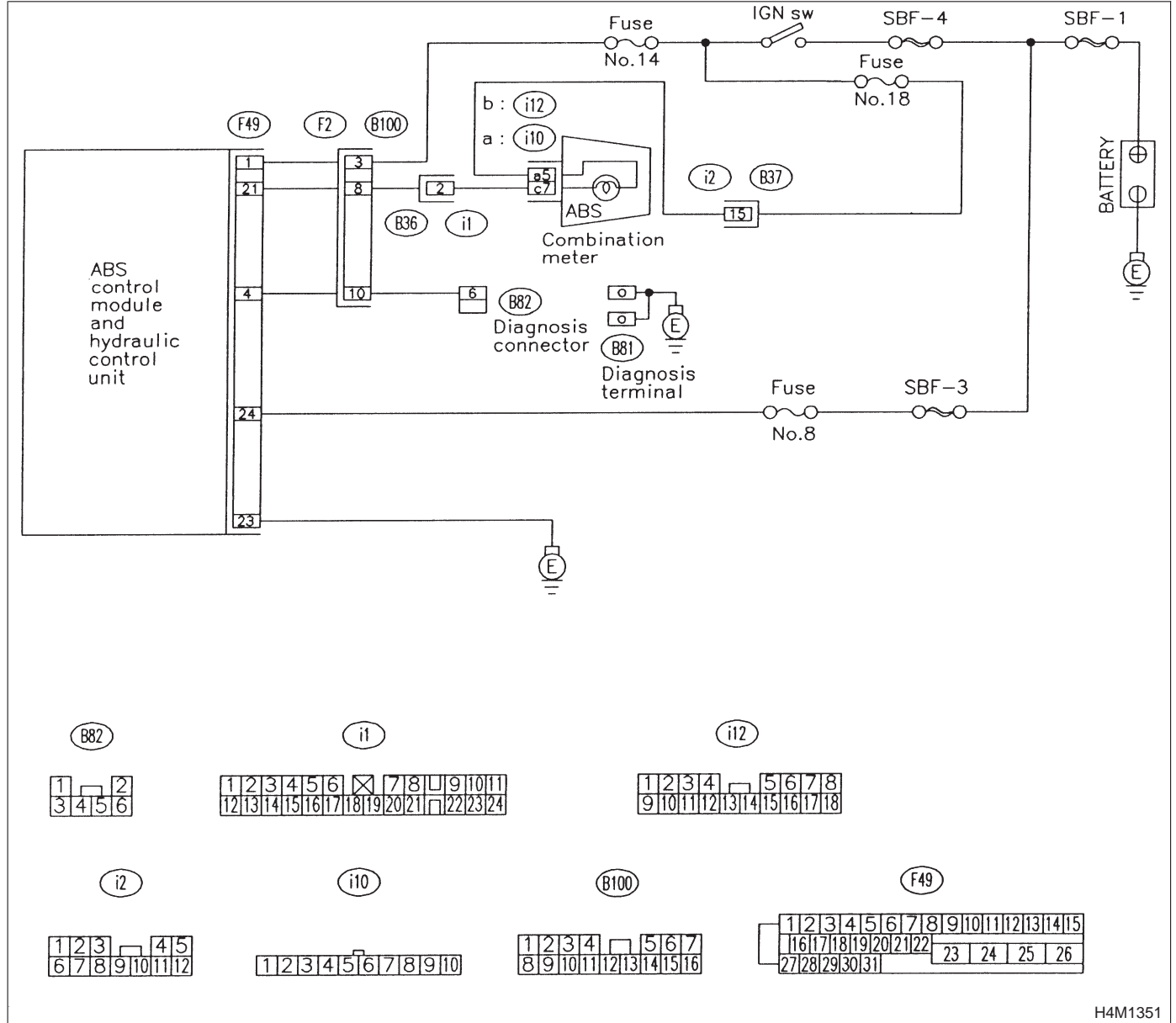

H4M1351

7B1 : CHECK INSTALLATION OF ABSCM&H/U CONNECTOR.

Turn ignition switch to OFF.

CHECK : *Is ABSCM&H/U connector inserted into ABSCM until the clamp locks onto it?*

YES : Go to step 7B2.

NO : Insert ABSCM&H/U connector into ABSCM&H/U until the clamp locks onto it.

7B2 : CHECK DIAGNOSIS TERMINAL.

Measure resistance between diagnosis terminals (B81) and chassis ground.

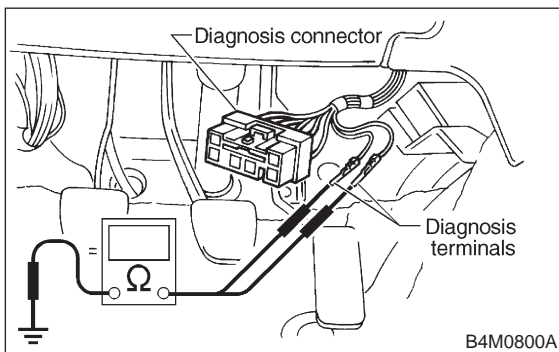

Terminals

Diagnosis terminal (A) — Chassis ground:

Diagnosis terminal (B) — Chassis ground:

CHECK : *Is the resistance less than 0.5 Ω?*

YES : Go to step 7B3.

NO : Repair diagnosis terminal harness.

7B3 : CHECK DIAGNOSIS LINE.

- 1) Turn ignition switch to OFF.
- 2) Connect diagnosis terminal (B81) to diagnosis connector (B82) No. 6.
- 3) Disconnect connector from ABSCM&H/U.
- 4) Measure resistance between ABSCM&H/U connector and chassis ground.

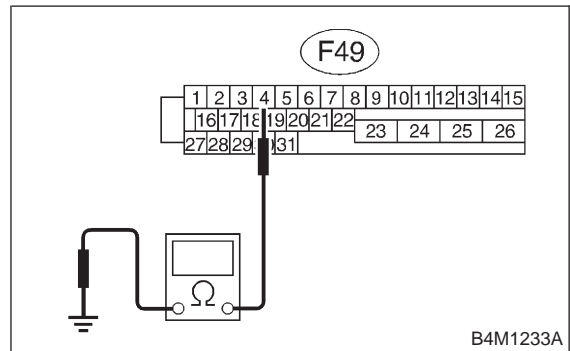

Connector & terminal (F49) No. 4 — Chassis ground:

CHECK : *Is the resistance less than 0.5 Ω?*

YES : Go to step 7B4.

NO : Repair harness connector between ABSCM&H/U and diagnosis connector.

7B4 : CHECK GENERATOR.

- 1) Start the engine.
- 2) Idle the engine.
- 3) Measure voltage between generator and chassis ground.

Terminal

Generator B terminal (+) — Chassis ground (-):

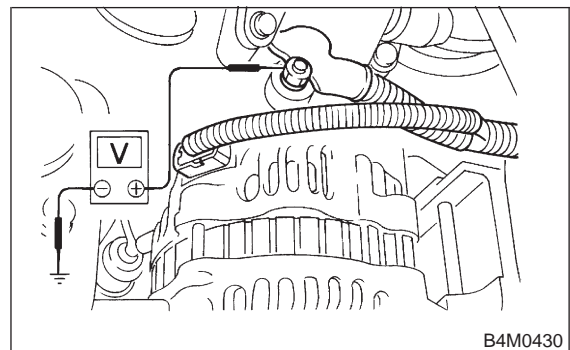

CHECK : *Is the voltage between 10 and 15 V?*

YES : Go to step 7B5.

NO : Repair generator.

7B5 : CHECK BATTERY TERMINAL.

Turn ignition switch to OFF.

CHECK : *Is there poor contact at battery terminal?*

YES : Repair battery terminal.

NO : Go to step **7B6**.

7B6 : CHECK POWER SUPPLY OF ABSCM.

- 1) Disconnect connector from ABSCM&H/U.
- 2) Start engine.
- 3) Idle the engine.
- 4) Measure voltage between ABSCM&H/U connector and chassis ground.

Connector & terminal

(F49) No. 1 (+) — Chassis ground (-):

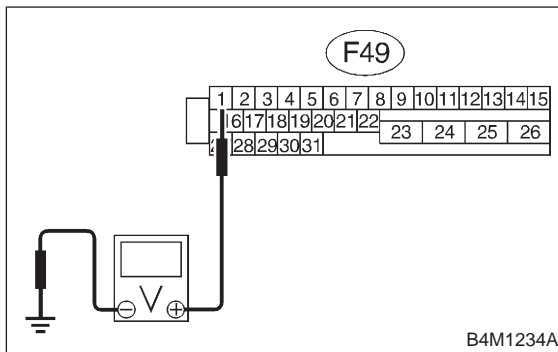

CHECK : *Is the voltage between 10 and 15 V?*

YES : Go to step **7B7**.

NO : Repair ABSCM&H/U power supply circuit.

7B7 : CHECK WIRING HARNESS.

- 1) Disconnect connector (F2) from connector (B100).
- 2) Turn ignition switch to ON.

CHECK : *Does the ABS warning light remain off?*

YES : Go to step **7B8**.

NO : Repair front wiring harness.

7B8 : CHECK PROJECTION AT ABSCM&H/U.

- 1) Turn ignition switch to OFF.
- 2) Check for broken projection at the ABSCM&H/U terminal.

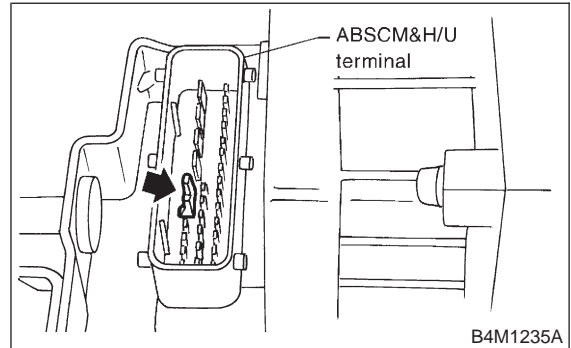

CHECK : *Are the projection broken?*

YES : Go to step **7B9**.

NO : Replace ABSCM&H/U.

7B9 : CHECK ABSCM&H/U.

Measure resistance between ABSCM&H/U terminals.

Terminal

No. 21 — No. 23:

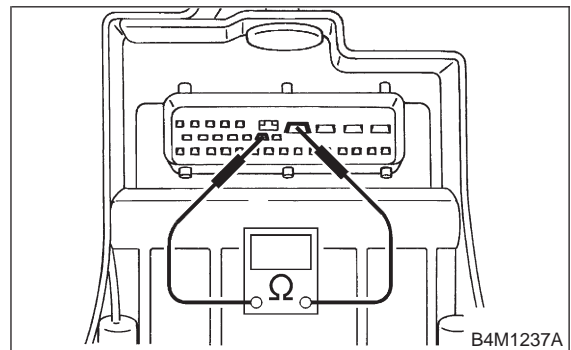

CHECK : *Is the resistance more than 1 MΩ?*

YES : Go to step **7B10**.

NO : Replace ABSCM&H/U.

7B10 : CHECK WIRING HARNESS.

Measure resistance between connector (F2) and chassis ground.

Connector & terminal
(F2) No. 8 — Chassis ground:

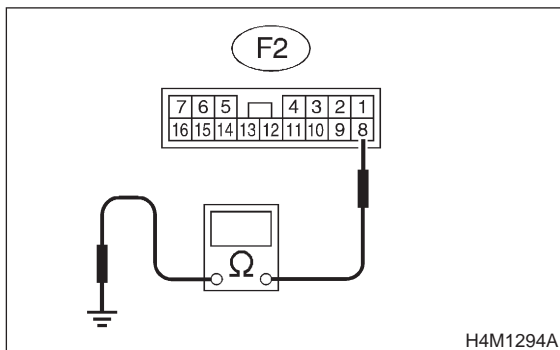

- CHECK** : *Is the resistance less than 0.5 Ω?*
- YES** : Go to step **7B11**.
- NO** : Repair harness.

7B11 : CHECK WIRING HARNESS.

- 1) Connect connector to ABSCM&H/U.
- 2) Measure resistance between connector (F2) and chassis ground.

Connector & terminal
(F2) No. 8 — Chassis ground:

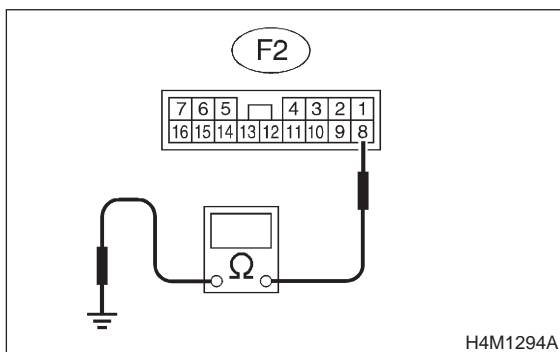

- CHECK** : *Is the resistance more than 1 MΩ?*
- YES** : Go to step **7B12**.
- NO** : Repair harness.

7B12 : CHECK POOR CONTACT IN ABSCM&H/U CONNECTOR.

- CHECK** : *Is there poor contact in ABSCM&H/U connector? <Ref. to FOREWORD [T3C1].>*
- YES** : Repair connector.
- NO** : Replace ABSCM&H/U.

C: TROUBLE CODE DOES NOT APPEAR.

DIAGNOSIS:

- Diagnosis circuit is open.

TROUBLE SYMPTOM:

- The ABS warning light turns on or off normally but the start code cannot be read out in the diagnostic mode.

WIRING DIAGRAM:

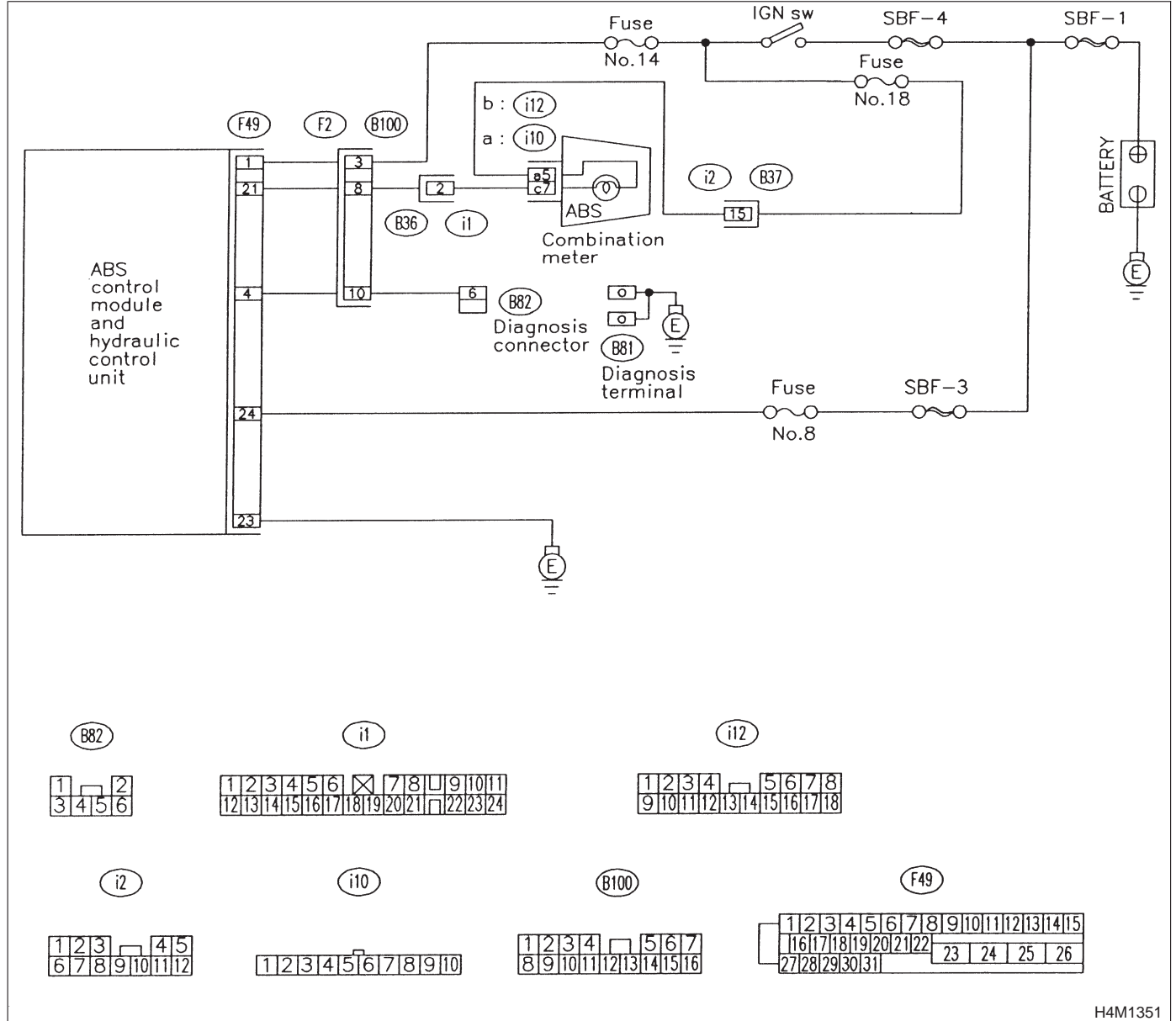

7C1 : CHECK DIAGNOSIS TERMINAL.

Measure resistance between diagnosis terminals (B81) and chassis ground.

Terminals

Diagnosis terminal (A) — Chassis ground:

Diagnosis terminal (B) — Chassis ground:

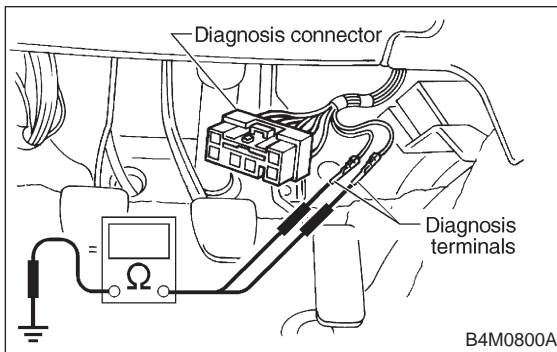

- CHECK** : *Is the resistance less than 0.5 Ω?*
- YES** : Go to step **7C2**.
- NO** : Repair diagnosis terminal harness.

7C2 : CHECK DIAGNOSIS LINE.

- 1) Turn ignition switch to OFF.
- 2) Connect diagnosis terminal (B81) to diagnosis connector (B82) No. 6.
- 3) Disconnect connector from ABSCM&H/U.
- 4) Measure resistance between ABSCM&H/U connector and chassis ground.

Connector & terminal

(F49) No. 4 — Chassis ground:

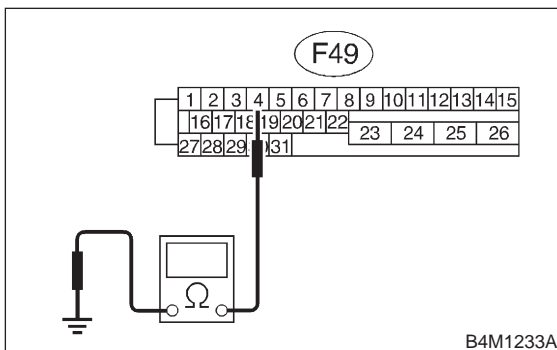

- CHECK** : *Is the resistance less than 0.5 Ω?*
- YES** : Go to step **7C3**.
- NO** : Repair harness connector between ABSCM&H/U and diagnosis connector.

7C3 : CHECK POOR CONTACT IN ABSCM&H/U CONNECTOR.

- CHECK** : *Is there poor contact in ABSCM&H/U connector? <Ref. to FOREWORD [T3C1].>*
- YES** : Repair connector.
- NO** : Replace ABSCM&H/U.

MEMO:

8. Diagnostics Chart with Trouble Code by ABS Warning Light

A: LIST OF TROUBLE CODE

Trouble code	Contents of diagnosis	Index No.
11	Start code <ul style="list-style-type: none"> ● Trouble code is shown after start code. ● Only start code is shown in normal condition. 	—
21	Abnormal ABS sensor (Open circuit or input voltage too high)	Front right ABS sensor
23		Front left ABS sensor
25		Rear right ABS sensor
27		Rear left ABS sensor
22	Abnormal ABS sensor (Abnormal ABS sensor signal)	Front right ABS sensor
24		Front left ABS sensor
26		Rear right ABS sensor
28		Rear left ABS sensor
29		Any one of four
31	Abnormal solenoid valve circuit(s) in ABS control module and hydraulic unit	Front right inlet valve
32		Front right outlet valve
33		Front left inlet valve
34		Front left outlet valve
35		Rear right inlet valve
36		Rear right outlet valve
37		Rear left inlet valve
38		Rear left outlet valve
41	Abnormal ABS control module	<Ref. to 4-4 [T8S0].>
42	Source voltage is abnormal.	<Ref. to 4-4 [T8T0].>
44	A combination of AT control abnormal	<Ref. to 4-4 [T8U0].>
51	Abnormal valve relay	<Ref. to 4-4 [T8V0].>
52	Abnormal motor and/or motor relay	<Ref. to 4-4 [T8W0].>
54	Abnormal stop light switch	<Ref. to 4-4 [T8X0].>
56	Abnormal G sensor output voltage	<Ref. to 4-4 [T8Y0].>

B: TROUBLE CODE 21 (FRONT RH)

C: TROUBLE CODE 23 (FRONT LH)

D: TROUBLE CODE 25 (REAR RH)

E: TROUBLE CODE 27 (REAR LH)

— ABNORMAL ABS SENSOR (OPEN CIRCUIT OR INPUT VOLTAGE TOO HIGH) —

DIAGNOSIS:

- Faulty ABS sensor (Broken wire, input voltage too high)
- Faulty harness connector

TROUBLE SYMPTOM:

- ABS does not operate.

WIRING DIAGRAM:

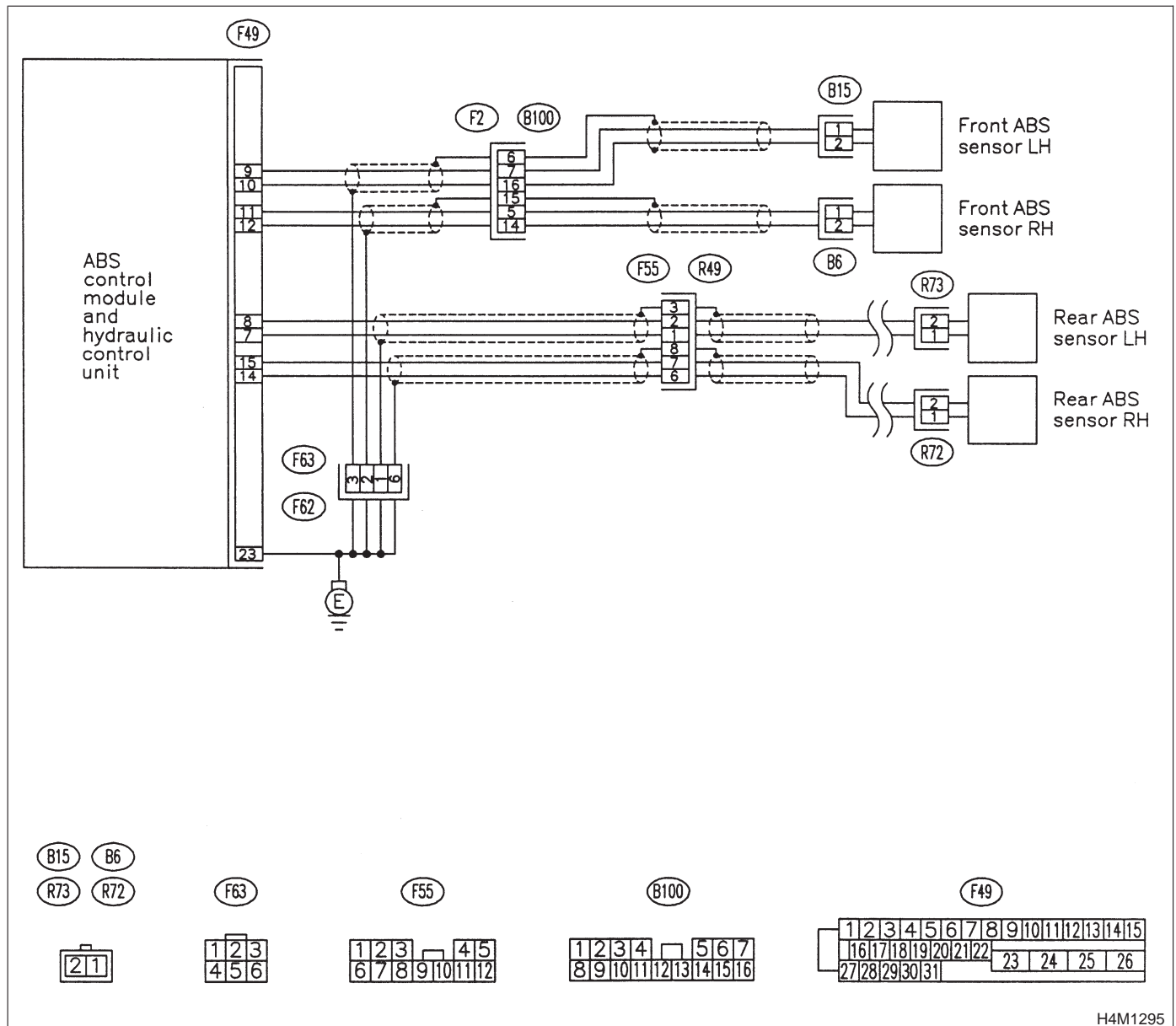

8E1 : CHECK ABS SENSOR.

- 1) Turn ignition switch to OFF.
- 2) Disconnect connector from ABS sensor.
- 3) Measure resistance of ABS sensor connector terminals.

Terminal

- Front RH No. 1 — No. 2:**
- Front LH No. 1 — No. 2:**
- Rear RH No. 1 — No. 2:**
- Rear LH No. 1 — No. 2:**

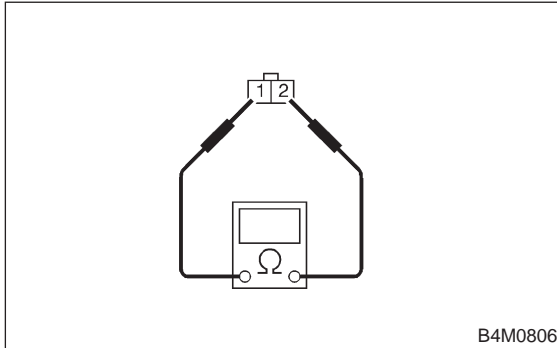

- CHECK** : **Is the resistance between 0.8 and 1.2 kΩ?**
- YES** : Go to step **8E2**.
- NO** : Replace ABS sensor.

8E2 : CHECK BATTERY SHORT OF ABS SENSOR.

- 1) Disconnect connector from ABSCM&H/U.
- 2) Measure voltage between ABS sensor and chassis ground.

Terminal

- Front RH No. 1 (+) — Chassis ground (-):**
- Front LH No. 1 (+) — Chassis ground (-):**
- Rear RH No. 1 (+) — Chassis ground (-):**
- Rear LH No. 1 (+) — Chassis ground (-):**

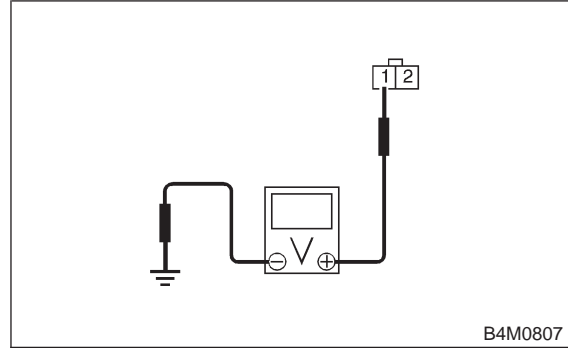

- CHECK** : **Is the voltage less than 1 V?**
- YES** : Go to step **8E3**.
- NO** : Replace ABS sensor.

8E3 : CHECK BATTERY SHORT OF ABS SENSOR.

- 1) Turn ignition switch to ON.
- 2) Measure voltage between ABS sensor and chassis ground.

Terminal

- Front RH No. 1 (+) — Chassis ground (-):**
- Front LH No. 1 (+) — Chassis ground (-):**
- Rear RH No. 1 (+) — Chassis ground (-):**
- Rear LH No. 1 (+) — Chassis ground (-):**

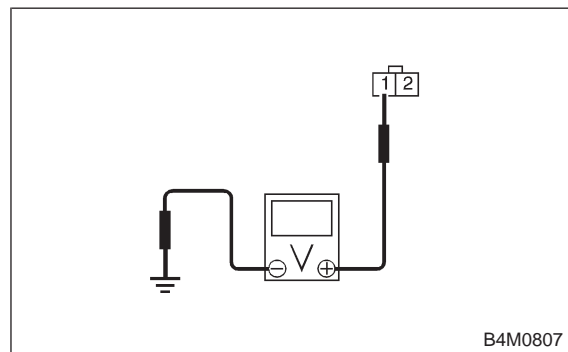

- CHECK** : **Is the voltage less than 1 V?**
- YES** : Go to step **8E4**.
- NO** : Replace ABS sensor.

8E4 : CHECK HARNESS/CONNECTOR BETWEEN ABSCM&H/U AND ABS SENSOR.

- 1) Turn ignition switch to OFF.
- 2) Connect connector to ABS sensor.
- 3) Measure resistance between ABSCM&H/U connector terminals.

Connector & terminal

- Trouble code 21 / (F49) No. 11 — No. 12:**
- Trouble code 23 / (F49) No. 9 — No. 10:**
- Trouble code 25 / (F49) No. 14 — No. 15:**
- Trouble code 27 / (F49) No. 7 — No. 8:**

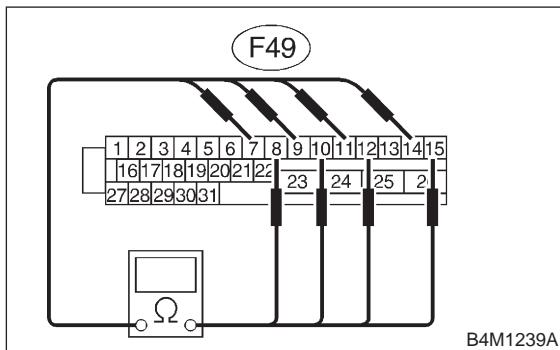

- CHECK** : *Is the resistance between 0.8 and 1.2 kΩ?*
- YES** : Go to step **8E5**.
- NO** : Repair harness/connector between ABSCM&H/U and ABS sensor.

8E5 : CHECK BATTERY SHORT OF HARNESS.

Measure voltage between ABSCM&H/U connector and chassis ground.

Connector & terminal

- Trouble code 21 / (F49) No. 11 (+) — Chassis ground (-):**
- Trouble code 23 / (F49) No. 9 (+) — Chassis ground (-):**
- Trouble code 25 / (F49) No. 14 (+) — Chassis ground (-):**
- Trouble code 27 / (F49) No. 7 (+) — Chassis ground (-):**

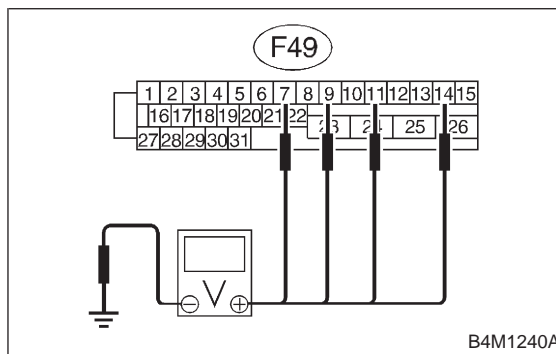

- CHECK** : *Is the voltage less than 1 V?*
- YES** : Go to step **8E6**.
- NO** : Repair harness between ABSCM&H/U and ABS sensor.

8E6 : CHECK BATTERY SHORT OF HARNESS.

- 1) Turn ignition switch to ON.
- 2) Measure voltage between ABSCM&H/U connector and chassis ground.

Connector & terminal

Trouble code 21 / (F49) No. 11 (+) — Chassis ground (-):
Trouble code 23 / (F49) No. 9 (+) — Chassis ground (-):
Trouble code 25 / (F49) No. 14 (+) — Chassis ground (-):
Trouble code 27 / (F49) No. 7 (+) — Chassis ground (-):

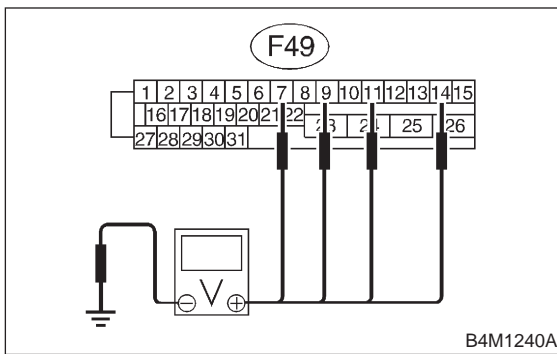

- CHECK** : *Is the voltage less than 1 V?*
- YES** : Go to step **8E7**.
- NO** : Repair harness between ABSCM&H/U and ABS sensor.

8E7 : CHECK INSTALLATION OF ABS SENSOR.

Tightening torque:

32±10 N·m (3.3±1.0 kg·m, 24±7 ft·lb)

- CHECK** : *Are the ABS sensor installation bolts tightened securely?*
- YES** : Go to step **8E8**.
- NO** : Tighten ABS sensor installation bolts securely.

8E8 : CHECK INSTALLATION OF TONE WHEEL.

Tightening torque:

13±3 N·m (1.3±0.3 kg·m, 9±2.2 ft·lb)

- CHECK** : *Are the tone wheel installation bolts tightened securely?*
- YES** : Go to step **8E9**.
- NO** : Tighten tone wheel installation bolts securely.

8E9 : CHECK ABS SENSOR GAP.

Measure tone wheel-to-pole piece gap over entire perimeter of the wheel.

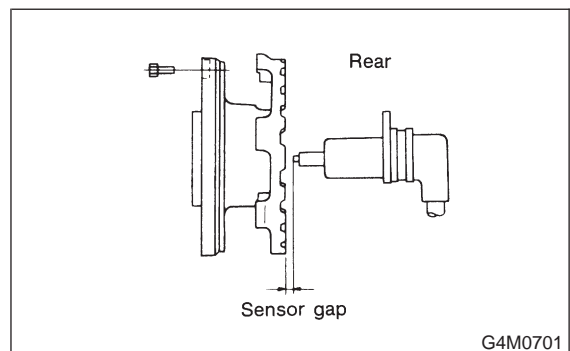
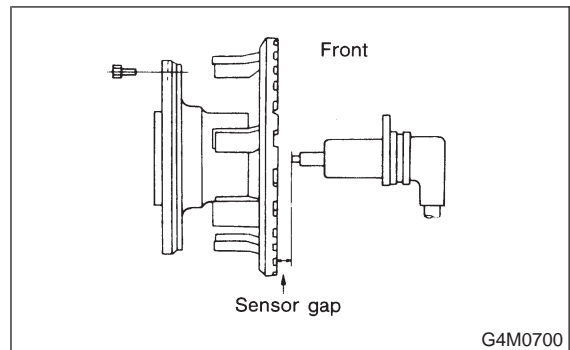

	Front wheel	Rear wheel
Specifications	0.9 — 1.4 mm (0.035 — 0.055 in)	0.7 — 1.2 mm (0.028 — 0.047 in)

- CHECK** : *Is the gap within the specifications?*
- YES** : Go to step **8E10**.
- NO** : Adjust the gap.

NOTE:

Adjust the gap using spacers (Part No. 26755AA000). If spacers cannot correct the gap, replace worn sensor or worn tone wheel.

8E10 : CHECK HUB RUNOUT.

Measure hub runout.

- CHECK** : *Is the runout less than 0.05 mm (0.0020 in)?*
- YES** : Go to step **8E11**.
- NO** : Repair hub.

8E11 : CHECK GROUND SHORT OF ABS SENSOR.

- 1) Turn ignition switch to ON.
- 2) Measure resistance between ABS sensor and chassis ground.

Terminal

- Front RH No. 1 — Chassis ground:**
- Front LH No. 1 — Chassis ground:**
- Rear RH No. 1 — Chassis ground:**
- Rear LH No. 1 — Chassis ground:**

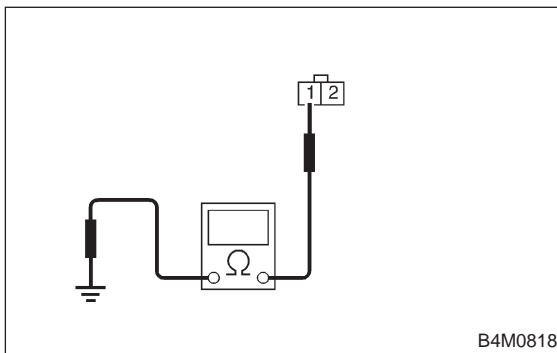

- CHECK** : *Is the resistance more than 1 MΩ?*
- YES** : Go to step **8E12**.
- NO** : Replace ABS sensor and ABSCM&H/U.

8E12 : CHECK GROUND SHORT OF HARNESS.

- 1) Turn ignition switch to OFF.
- 2) Connect connector to ABS sensor.
- 3) Measure resistance between ABSCM&H/U connector terminal and chassis ground.

Connector & terminal

- Trouble code 21 / (F49) No. 11 — Chassis ground:**
- Trouble code 23 / (F49) No. 9 — Chassis ground:**
- Trouble code 25 / (F49) No. 14 — Chassis ground:**
- Trouble code 27 / (F49) No. 7 — Chassis ground:**

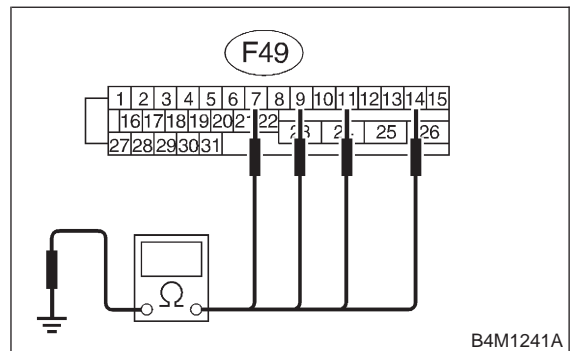

- CHECK** : *Is the resistance more than 1 MΩ?*
- YES** : Go to step **8E13**.
- NO** : Repair harness between ABSCM&H/U and ABS sensor. Replace ABSCM&H/U.

8E13 : CHECK POOR CONTACT IN CONNECTORS.

- CHECK** : *Is there poor contact in connectors between ABSCM&H/U and ABS sensor? <Ref. to FOREWORD [T3C1].>*
- YES** : Repair connector.
- NO** : Go to step **8E14**.

8E14 : CHECK ABSCM&H/U.

- 1) Connect all connectors.
- 2) Erase the memory.
- 3) Perform inspection mode.
- 4) Read out the trouble code.

CHECK : *Is the same trouble code as in the current diagnosis still being output?*

YES : Replace ABSCM&H/U.

NO : Go to step **8E15**.

8E15 : CHECK ANY OTHER TROUBLE CODES APPEARANCE.

CHECK : *Are other trouble codes being output?*

YES : Proceed with the diagnosis corresponding to the trouble code.

NO : A temporary poor contact.

NOTE:

Check harness and connectors between ABSCM&H/U and ABS sensor.

F: TROUBLE CODE 22 (FRONT RH)

G: TROUBLE CODE 24 (FRONT LH)

H: TROUBLE CODE 26 (REAR RH)

I: TROUBLE CODE 28 (REAR LH)

— ABNORMAL ABS SENSOR (ABNORMAL ABS SENSOR SIGNAL) —

DIAGNOSIS:

- Faulty ABS sensor signal (noise, irregular signal, etc.)
- Faulty harness/connector

TROUBLE SYMPTOM:

- ABS does not operate.

WIRING DIAGRAM:

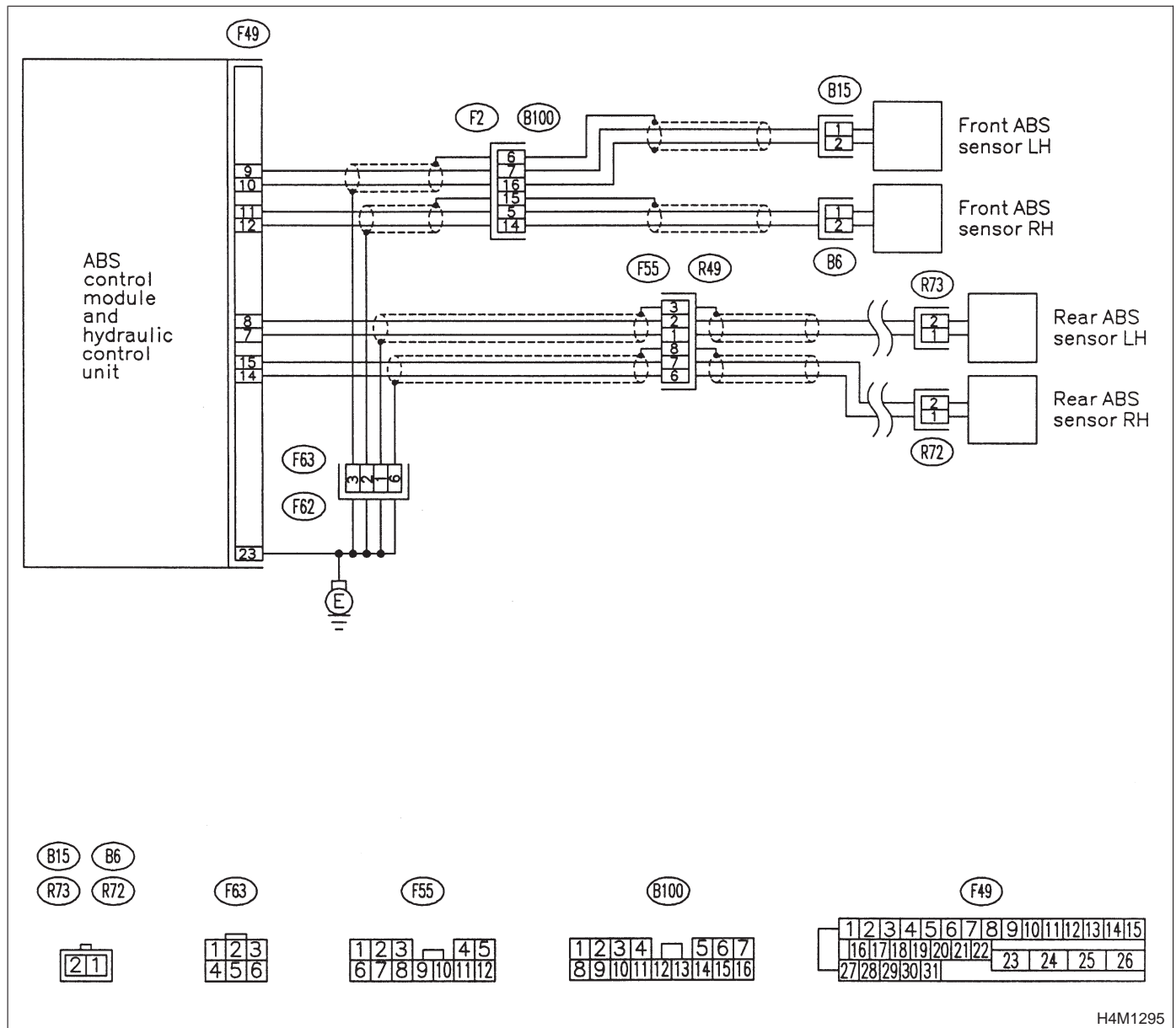

811 : CHECK INSTALLATION OF ABS SENSOR.

Tightening torque:

32±10 N·m (3.3±1.0 kg·m, 24±7 ft·lb)

- CHECK** : Are the ABS sensor installation bolts tightened securely?
- YES** : Go to step 812.
- NO** : Tighten ABS sensor installation bolts securely.

812 : CHECK INSTALLATION OF TONE WHEEL.

Tightening torque:

13±3 N·m (1.3±0.3 kg·m, 9±2.2 ft·lb)

- CHECK** : Are the tone wheel installation bolts tightened securely?
- YES** : Go to step 813.
- NO** : Tighten tone wheel installation bolts securely.

813 : CHECK ABS SENSOR GAP.

Measure tone wheel to pole piece gap over entire perimeter of the wheel.

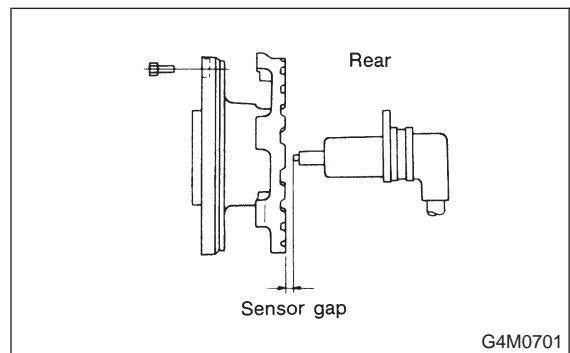
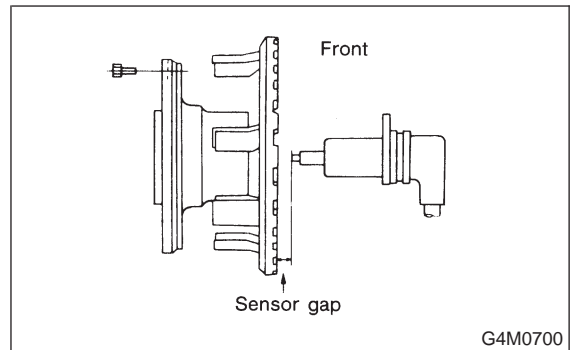

	Front wheel	Rear wheel
Specifications	0.9 — 1.4 mm (0.035 — 0.055 in)	0.7 — 1.2 mm (0.028 — 0.047 in)

- CHECK** : Is the gap within the specifications?
- YES** : Go to step 814.
- NO** : Adjust the gap.

NOTE:

Adjust the gap using spacer (Part No. 26755AA000). If spacers cannot correct the gap, replace worn sensor or worn tone wheel.

814 : CHECK OSCILLOSCOPE.

- CHECK** : Is an oscilloscope available?
- YES** : Go to step 815.
- NO** : Go to step 816.

815 : CHECK ABS SENSOR SIGNAL.

- 1) Raise all four wheels of ground.
- 2) Turn ignition switch OFF.
- 3) Connect the oscilloscope to the connector.
- 4) Turn ignition switch ON.
- 5) Rotate wheels and measure voltage at specified frequency.

NOTE:

When this inspection is completed, the ABSCM&H/U sometimes stores the trouble code 29.

Connector & terminal

Trouble code 22 / (B100) No. 5 (+) — No. 14 (-):

Trouble code 24 / (B100) No. 7 (+) — No. 16 (-):

Trouble code 26 / (F55) No. 6 (+) — No. 7 (-):

Trouble code 28 / (F55) No. 1 (+) — No. 2 (-):

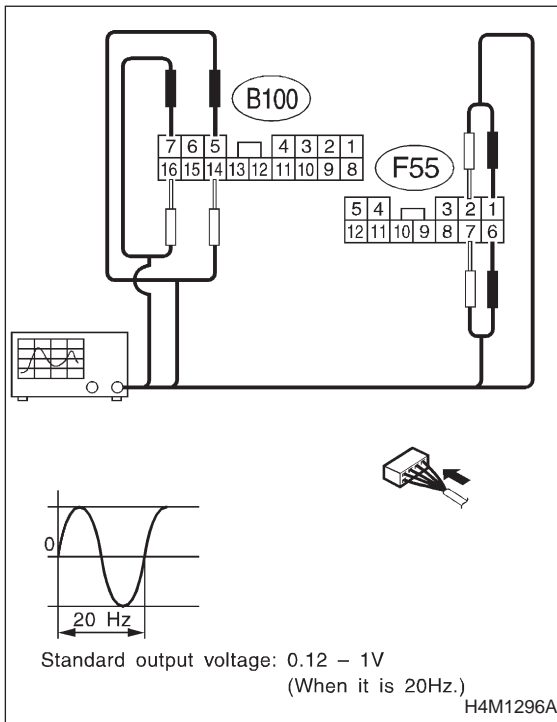

CHECK : *Is oscilloscope pattern smooth, as shown in figure?*

YES : Go to step **819**.

NO : Go to step **816**.

816 : CHECK CONTAMINATION OF ABS SENSOR OR TONE WHEEL.

Remove disc rotor or drum from hub in accordance with trouble code.

CHECK : *Is the ABS sensor pole piece or the tone wheel contaminated by dirt or other foreign matter?*

YES : Thoroughly remove dirt or other foreign matter.

NO : Go to step **817**.

817 : CHECK DAMAGE OF ABS SENSOR OR TONE WHEEL.

CHECK : *Are there broken or damaged in the ABS sensor pole piece or the tone wheel?*

YES : Replace ABS sensor or tone wheel.

NO : Go to step **818**.

818 : CHECK HUB RUNOUT.

Measure hub runout.

CHECK : *Is the runout less than 0.05 mm (0.0020 in)?*

YES : Go to step **819**.

NO : Repair hub.

8I9 : CHECK RESISTANCE OF ABS SENSOR.

- 1) Turn ignition switch OFF.
- 2) Disconnect connector from ABS sensor.
- 3) Measure resistance between ABS sensor connector terminals.

Terminal

Front RH No. 1 — No. 2:

Front LH No. 1 — No. 2:

Rear RH No. 1 — No. 2:

Rear LH No. 1 — No. 2:

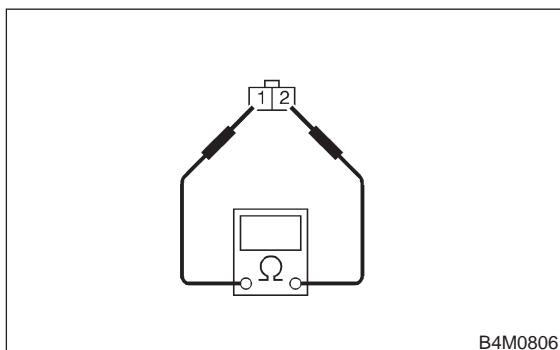

CHECK : *Is the resistance between 0.8 and 1.2 kΩ?*

YES : Go to step **8I10**.

NO : Replace ABS sensor.

8I10 : CHECK GROUND SHORT OF ABS SENSOR.

Measure resistance between ABS sensor and chassis ground.

Terminal

Front RH No. 1 — Chassis ground:

Front LH No. 1 — Chassis ground:

Rear RH No. 1 — Chassis ground:

Rear LH No. 1 — Chassis ground:

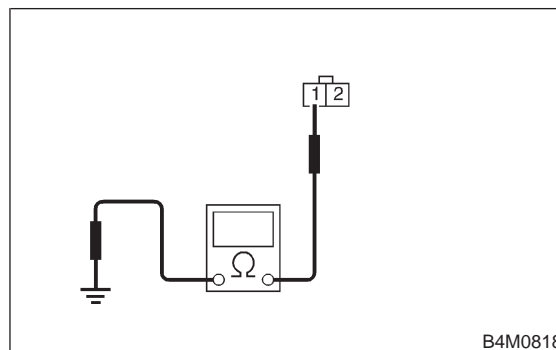

CHECK : *Is the resistance more than 1 MΩ?*

YES : Go to step **8I11**.

NO : Replace ABS sensor.

8I11 : CHECK HARNESS/CONNECTOR BETWEEN ABSCM&H/U AND ABS SENSOR.

- 1) Connect connector to ABS sensor.
- 2) Disconnect connector from ABSCM&H/U.
- 3) Measure resistance at ABSCM&H/U connector terminals.

Connector & terminal

- Trouble code 22 / (F49) No. 11 — No. 12:
- Trouble code 24 / (F49) No. 9 — No. 10:
- Trouble code 26 / (F49) No. 14 — No. 15:
- Trouble code 28 / (F49) No. 7 — No. 8:

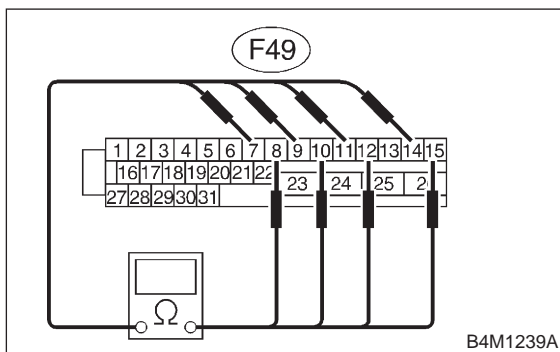

- CHECK** : Is the resistance between 0.8 and 1.2 kΩ?
- YES** : Go to step 8I12.
- NO** : Repair harness/connector between ABSCM&H/U and ABS sensor.

8I12 : CHECK GROUND SHORT OF HARNESS.

Measure resistance between ABSCM&H/U connector and chassis ground.

Connector & terminal

- Trouble code 22 / (F49) No. 11 — Chassis ground:
- Trouble code 24 / (F49) No. 9 — Chassis ground:
- Trouble code 26 / (F49) No. 14 — Chassis ground:
- Trouble code 28 / (F49) No. 7 — Chassis ground:

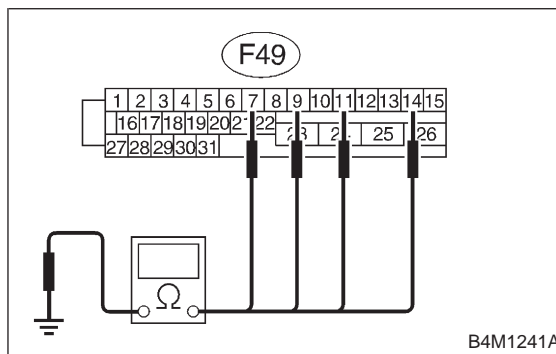

- CHECK** : Is the resistance more than 1 MΩ?
- YES** : Go to step 8I13.
- NO** : Repair harness/connector between ABSCM&H/U and ABS sensor.

8I13 : CHECK GROUND CIRCUIT OF ABSCM&H/U.

Measure resistance between ABSCM&H/U and chassis ground.

Connector & terminal

- (F49) No. 23 — GND:

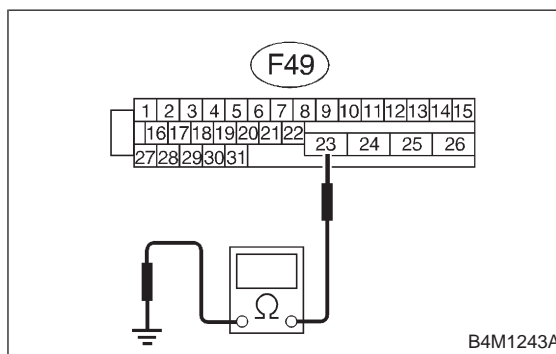

- CHECK** : Is the resistance less than 0.5 Ω?
- YES** : Go to step 8I14.
- NO** : Repair ABSCM&H/U ground harness.

8I14 : CHECK POOR CONTACT IN CONNECTORS.

CHECK : *Is there poor contact in connectors between ABSCM&H/U and ABS sensor? <Ref. to FOREWORD [T3C1].>*

YES : Repair connector.

NO : Go to step 8I15.

8I15 : CHECK SOURCES OF SIGNAL NOISE.

CHECK : *Is the car telephone or the wireless transmitter properly installed?*

YES : Go to step 8I16.

NO : Properly install the car telephone or the wireless transmitter.

8I16 : CHECK SOURCES OF SIGNAL NOISE.

CHECK : *Are noise sources (such as an antenna) installed near the sensor harness?*

YES : Install the noise sources apart from the sensor harness.

NO : Go to step 8I17.

8I17 : CHECK SHIELD CIRCUIT.

- 1) Connect all connectors.
- 2) Measure resistance between shield connector and chassis ground.

Connector & terminal

Trouble code 22 / (B100) No. 15 — Chassis ground:

Trouble code 24 / (B100) No. 6 — Chassis ground:

Trouble code 26 / (F55) No. 8 — Chassis ground:

Trouble code 28 / (F55) No. 3 — Chassis ground:

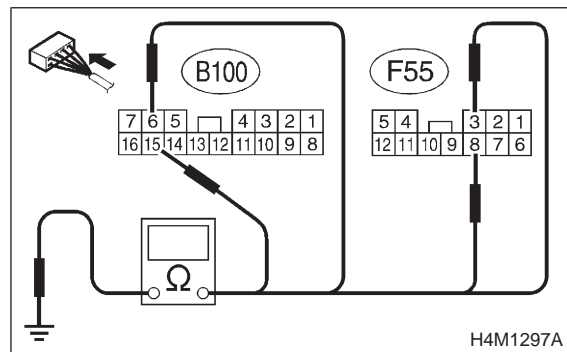

CHECK : *Is the resistance less than 0.5 Ω?*

YES : Go to step 8I18.

NO : Repair shield harness.

8I18 : CHECK ABSCM&H/U.

- 1) Connect all connectors.
- 2) Erase the memory.
- 3) Perform inspection mode.
- 4) Read out the trouble code.

CHECK : *Is the same trouble code as in the current diagnosis still being output?*

YES : Replace ABSCM&H/U.

NO : Go to step 8I19.

8I19 : CHECK ANY OTHER TROUBLE CODES APPEARANCE.

CHECK : *Are other trouble codes being output?*

YES : Proceed with the diagnosis corresponding to the trouble code.

NO : A temporary noise interference.

J: TROUBLE CODE 29

— ABNORMAL ABS SENSOR SIGNAL (ANY ONE OF FOUR) —

DIAGNOSIS:

- Faulty ABS sensor signal (noise, irregular signal, etc.)
- Faulty tone wheel
- Wheels turning freely for a long time

TROUBLE SYMPTOM:

- ABS does not operate.

WIRING DIAGRAM:

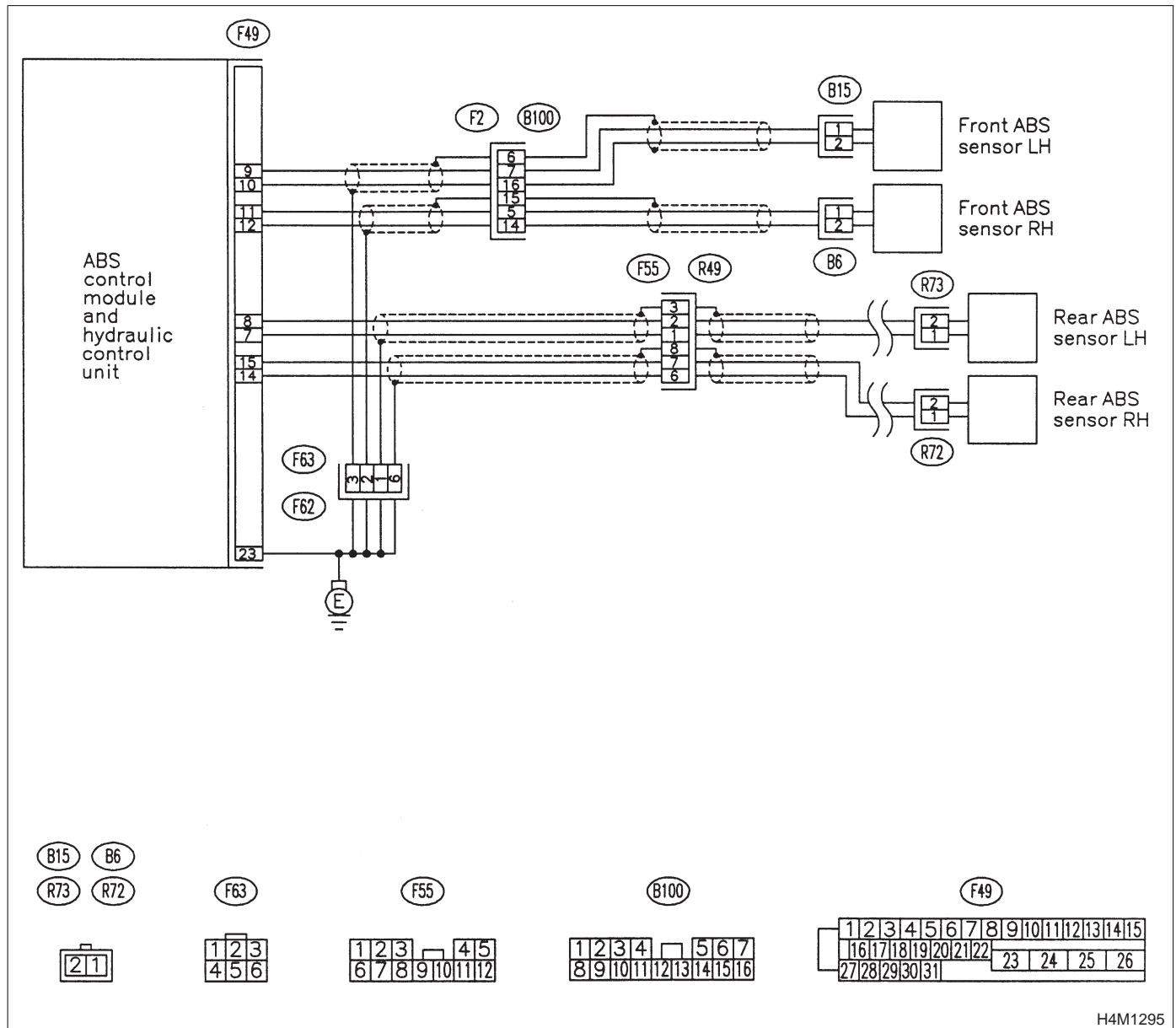

H4M1295

8J1 : CHECK IF THE WHEELS HAVE TURNED FREELY FOR A LONG TIME.

CHECK : Check if the wheels have been turned freely for more than one minute, such as when the vehicle is jacked-up, under full-lock cornering or when tire is not in contact with road surface.

YES : The ABS is normal. Erase the trouble code.

NOTE:

When the wheels turn freely for a long time, such as when the vehicle is towed or jacked-up, or when steering wheel is continuously turned all the way, this trouble code may sometimes occur.

NO : Go to step 8J2.

8J2 : CHECK TIRE SPECIFICATIONS.

CHECK : Are the tire specifications correct?

YES : Go to step 8J3.

NO : Replace tire.

8J3 : CHECK WEAR OF TIRE.

CHECK : Is the tire worn excessively?

YES : Replace tire.

NO : Go to step 8J4.

8J4 : CHECK TIRE PRESSURE.

CHECK : Is the tire pressure correct?

YES : Go to step 8J5.

NO : Adjust tire pressure.

8J5 : CHECK INSTALLATION OF ABS SENSOR.

Tightening torque:

32±10 N-m (3.3±1.0 kg-m, 24±7 ft-lb)

CHECK : Are the ABS sensor installation bolts tightened securely?

YES : Go to step 8J6.

NO : Tighten ABS sensor installation bolts securely.

8J6 : CHECK INSTALLATION OF TONE WHEEL.

Tightening torque:

13±3 N-m (1.3±0.3 kg-m, 9±2.2 ft-lb)

CHECK : Are the tone wheel installation bolts tightened securely?

YES : Go to step 8J7.

NO : Tighten tone wheel installation bolts securely.

8J7 : CHECK ABS SENSOR GAP.

Measure tone wheel to pole piece gap over entire perimeter of the wheel.

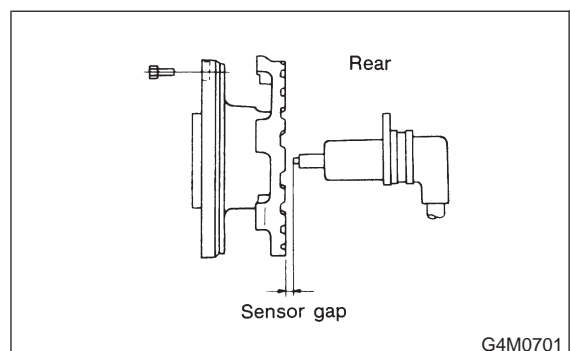
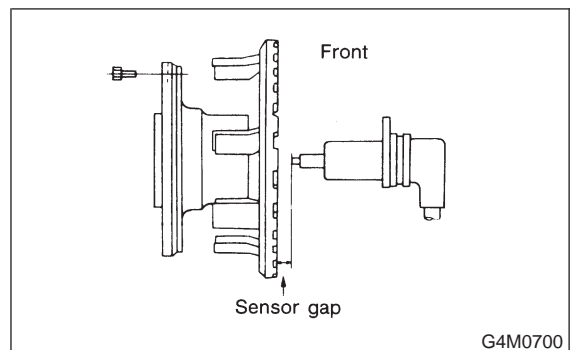

	Front wheel	Rear wheel
Specifications	0.9 — 1.4 mm (0.035 — 0.055 in)	0.7 — 1.2 mm (0.028 — 0.047 in)

CHECK : Is the gap within the specifications?

YES : Go to step 8J8.

NO : Adjust the gap.

NOTE:

Adjust the gap using spacer (Part No. 26755AA000). If spacers cannot correct the gap, replace worn sensor or worn tone wheel.

8J8 : CHECK OSCILLOSCOPE.

- CHECK** : *Is an oscilloscope available?*
- YES** : Go to step **8J9**.
- NO** : Go to step **8J10**.

8J9 : CHECK ABS SENSOR SIGNAL.

- 1) Raise all four wheels of ground.
- 2) Turn ignition switch OFF.
- 3) Connect the oscilloscope to the connector.
- 4) Turn ignition switch ON.
- 5) Rotate wheels and measure voltage at specified frequency.

NOTE:

When this inspection is completed, the ABSCM&H/U sometimes stores the trouble code 29.

Connector & terminal

- (B100) No. 5 (+) — No. 14 (-) (Front RH):**
- (B100) No. 7 (+) — No. 16 (-) (Front LH):**
- (F55) No. 6 (+) — No. 7 (-) (Rear RH):**
- (F55) No. 1 (+) — No. 2 (-) (Rear LH):**

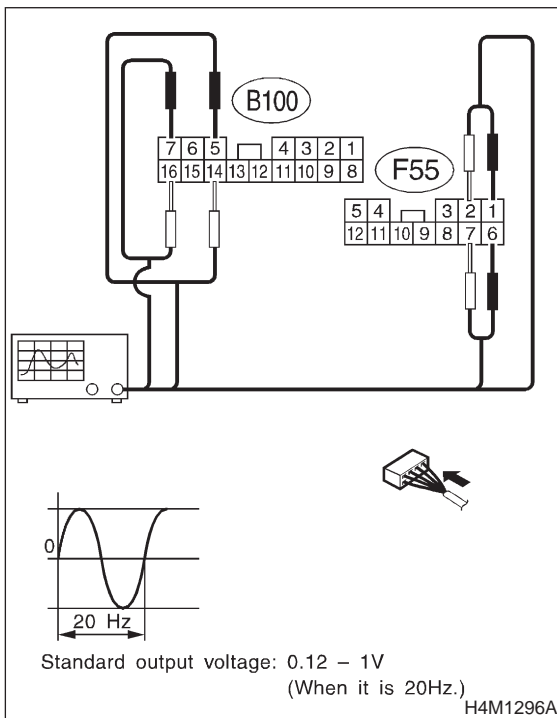

- CHECK** : *Is oscilloscope pattern smooth, as shown in figure?*
- YES** : Go to step **8J13**.
- NO** : Go to step **8J10**.

8J10 : CHECK CONTAMINATION OF ABS SENSOR OR TONE WHEEL.

Remove disc rotor from hub.

- CHECK** : *Is the ABS sensor pole piece or the tone wheel contaminated by dirt or other foreign matter?*
- YES** : Thoroughly remove dirt or other foreign matter.
- NO** : Go to step **8J11**.

8J11 : CHECK DAMAGE OF ABS SENSOR OR TONE WHEEL.

- CHECK** : *Are there broken or damaged teeth in the ABS sensor pole piece or the tone wheel?*
- YES** : Replace ABS sensor or tone wheel.
- NO** : Go to step **8J12**.

8J12 : CHECK HUB RUNOUT.

Measure hub runout.

- CHECK** : *Is the runout less than 0.05 mm (0.0020 in)?*
- YES** : Go to step **8J13**.
- NO** : Repair hub.

8J13 : CHECK ABSCM&H/U.

- 1) Turn ignition switch to OFF.
- 2) Connect all connectors.
- 3) Erase the memory.
- 4) Perform inspection mode.
- 5) Read out the trouble code.

- CHECK** : *Is the same trouble code as in the current diagnosis still being output?*
- YES** : Replace ABSCM&H/U.
- NO** : Go to step **8J14**.

8J14 : CHECK ANY OTHER TROUBLE CODES APPEARANCE.

- CHECK** : *Are other trouble codes being output?*
- YES** : Proceed with the diagnosis corresponding to the trouble code.
- NO** : A temporary poor contact.

MEMO:

K: TROUBLE CODE 31 (FRONT RH)

L: TROUBLE CODE 33 (FRONT LH)

M: TROUBLE CODE 35 (REAR RH)

N: TROUBLE CODE 37 (REAR LH)

— ABNORMAL INLET SOLENOID VALVE CIRCUIT(S) IN ABSCM&H/U —

DIAGNOSIS:

- Faulty harness/connector
- Faulty inlet solenoid valve in ABSCM&H/U

TROUBLE SYMPTOM:

- ABS does not operate.

WIRING DIAGRAM:

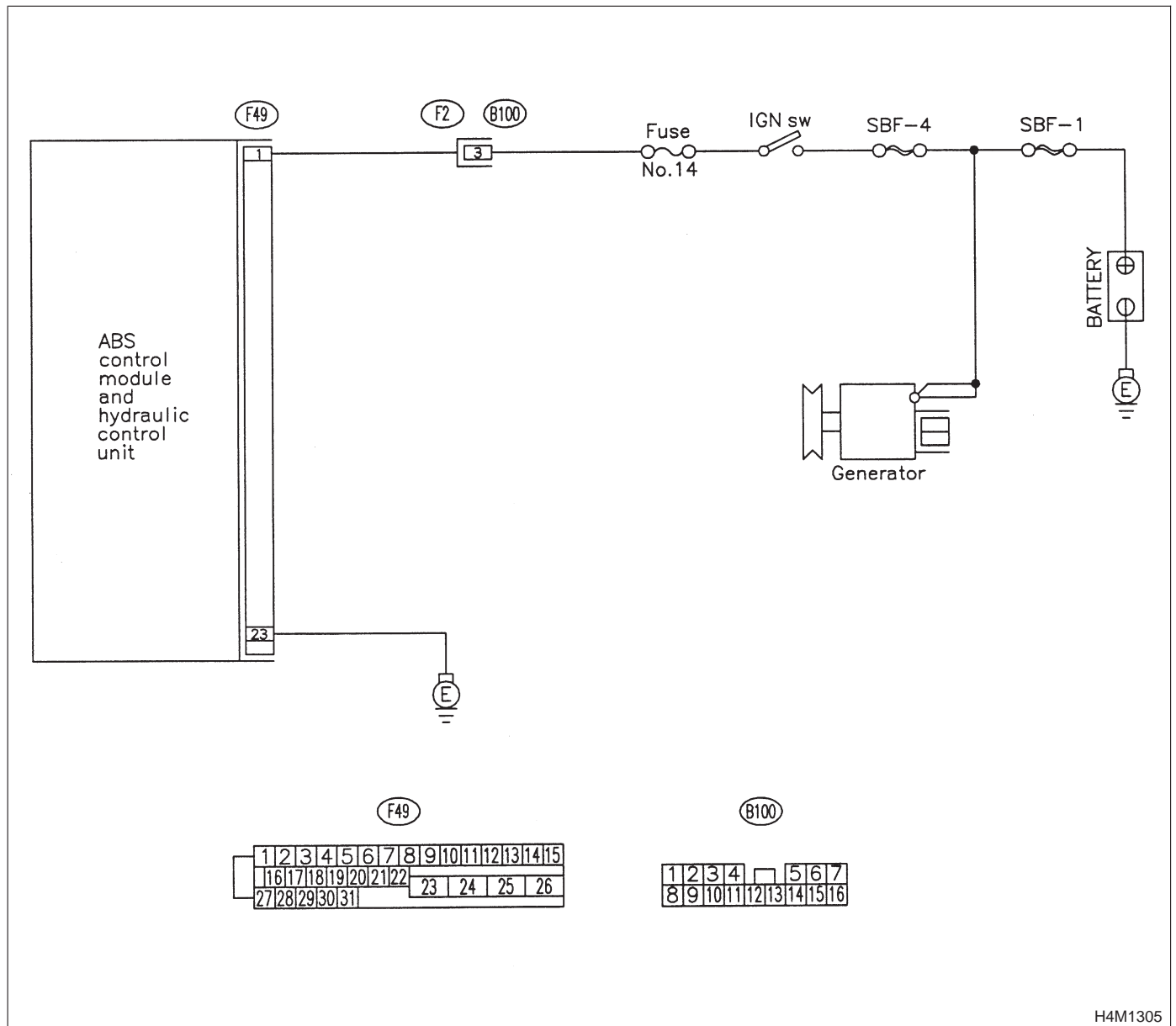

8N1 : CHECK INPUT VOLTAGE OF ABSCM&H/U.

- 1) Disconnect connector from ABSCM&H/U.
- 2) Run the engine at idle.
- 3) Measure voltage between ABSCM&H/U connector and chassis ground.

Connector & terminal

(F49) No. 1 (+) — Chassis ground (-):

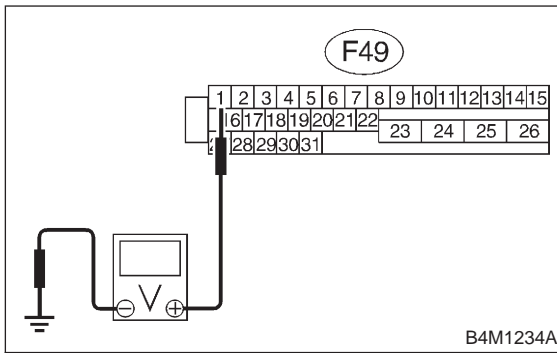

- CHECK** : **Is the voltage between 10 V and 15 V?**
- YES** : Go to step **8N2**.
- NO** : Repair harness connector between battery, ignition switch and ABSCM&H/U.

8N2 : CHECK GROUND CIRCUIT OF ABSCM&H/U.

- 1) Turn ignition switch to OFF.
- 2) Measure resistance between ABSCM&H/U connector and chassis ground.

Connector & terminal

(F49) No. 23 — Chassis ground:

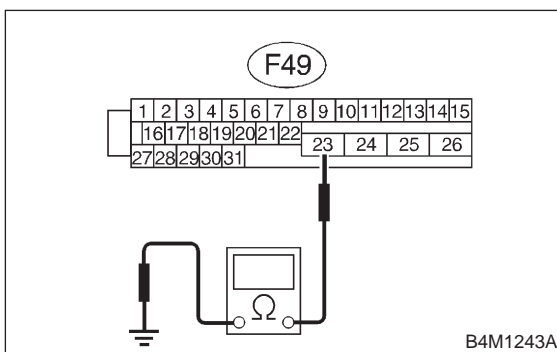

- CHECK** : **Is the resistance less than 0.5 Ω?**
- YES** : Go to step **8N3**.
- NO** : Repair ABSCM&H/U ground harness.

8N3 : CHECK POOR CONTACT IN CONNECTORS.

- CHECK** : **Is there poor contact in connectors between generator, battery and ABSCM&H/U? <Ref. to FOREWORD [T3C1].>**

- YES** : Repair connector.
- NO** : Go to step **8N4**.

8N4 : CHECK ABSCM&H/U.

- 1) Connect all connectors.
- 2) Erase the memory.
- 3) Perform inspection mode.
- 4) Read out the trouble code.

- CHECK** : **Is the same trouble code as in the current diagnosis still being output?**

- YES** : Replace ABSCM&H/U.
- NO** : Go to step **8N5**.

8N5 : CHECK ANY OTHER TROUBLE CODES APPEARANCE.

- CHECK** : **Are other trouble codes being output?**

- YES** : Proceed with the diagnosis corresponding to the trouble code.
- NO** : A temporary poor contact.

O: TROUBLE CODE 32 (FRONT RH)

P: TROUBLE CODE 34 (FRONT LH)

Q: TROUBLE CODE 36 (REAR RH)

R: TROUBLE CODE 38 (REAR LH)

— ABNORMAL OUTLET SOLENOID VALVE CIRCUIT(S) IN ABSCM&H/U —

DIAGNOSIS:

- Faulty harness/connector
- Faulty outlet solenoid valve in ABSCM&H/U

TROUBLE SYMPTOM:

- ABS does not operate.

WIRING DIAGRAM:

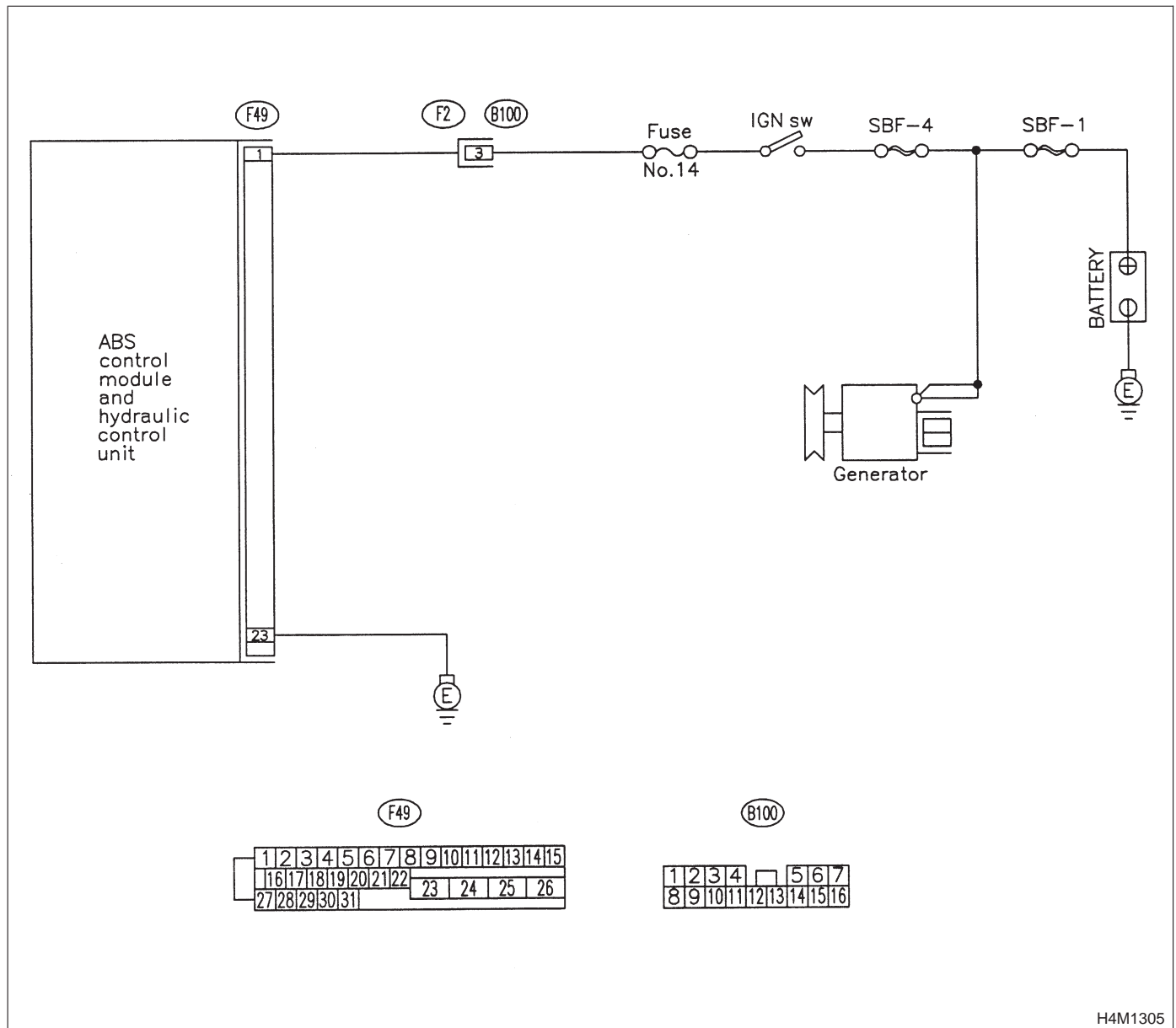

8R1 : CHECK INPUT VOLTAGE OF ABSCM&H/U.

- 1) Disconnect connector from ABSCM&H/U.
- 2) Run the engine at idle.
- 3) Measure voltage between ABSCM&H/U connector and chassis ground.

Connector & terminal

(F49) No. 1 (+) — Chassis ground (-):

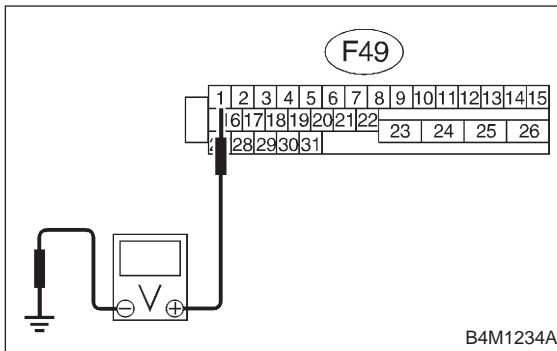

- CHECK** : **Is the voltage between 10 V and 15 V?**
- YES** : Go to step **8R2**.
- NO** : Repair harness connector between battery, ignition switch and ABSCM&H/U.

8R2 : CHECK GROUND CIRCUIT OF ABSCM&H/U.

- 1) Turn ignition switch to OFF.
- 2) Measure resistance between ABSCM&H/U connector and chassis ground.

Connector & terminal

(F49) No. 23 — Chassis ground:

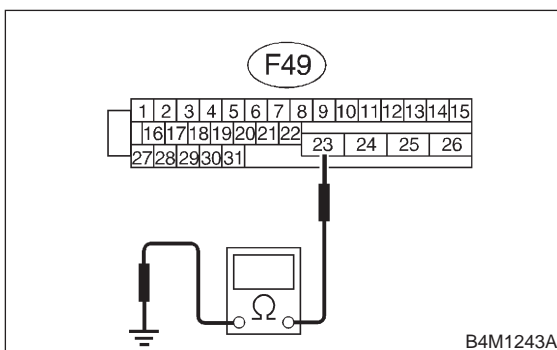

- CHECK** : **Is the resistance less than 0.5 Ω?**
- YES** : Go to step **8R3**.
- NO** : Repair ABSCM&H/U ground harness.

8R3 : CHECK POOR CONTACT IN CONNECTORS.

- CHECK** : **Is there poor contact in connectors between generator, battery and ABSCM&H/U? <Ref. to FOREWORD [T3C1].>**

- YES** : Repair connector.
- NO** : Go to step **8R4**.

8R4 : CHECK ABSCM&H/U.

- 1) Connect all connectors.
- 2) Erase the memory.
- 3) Perform inspection mode.
- 4) Read out the trouble code.

- CHECK** : **Is the same trouble code as in the current diagnosis still being output?**

- YES** : Replace ABSCM&H/U.
- NO** : Go to step **8R5**.

8R5 : CHECK ANY OTHER TROUBLE CODES APPEARANCE.

- CHECK** : **Are other trouble codes being output?**

- YES** : Proceed with the diagnosis corresponding to the trouble code.
- NO** : A temporary poor contact.

S: TROUBLE CODE 41
— ABNORMAL ABS CONTROL MODULE —

DIAGNOSIS:

- Faulty ABSCM&H/U

TROUBLE SYMPTOM:

- ABS does not operate.

WIRING DIAGRAM:

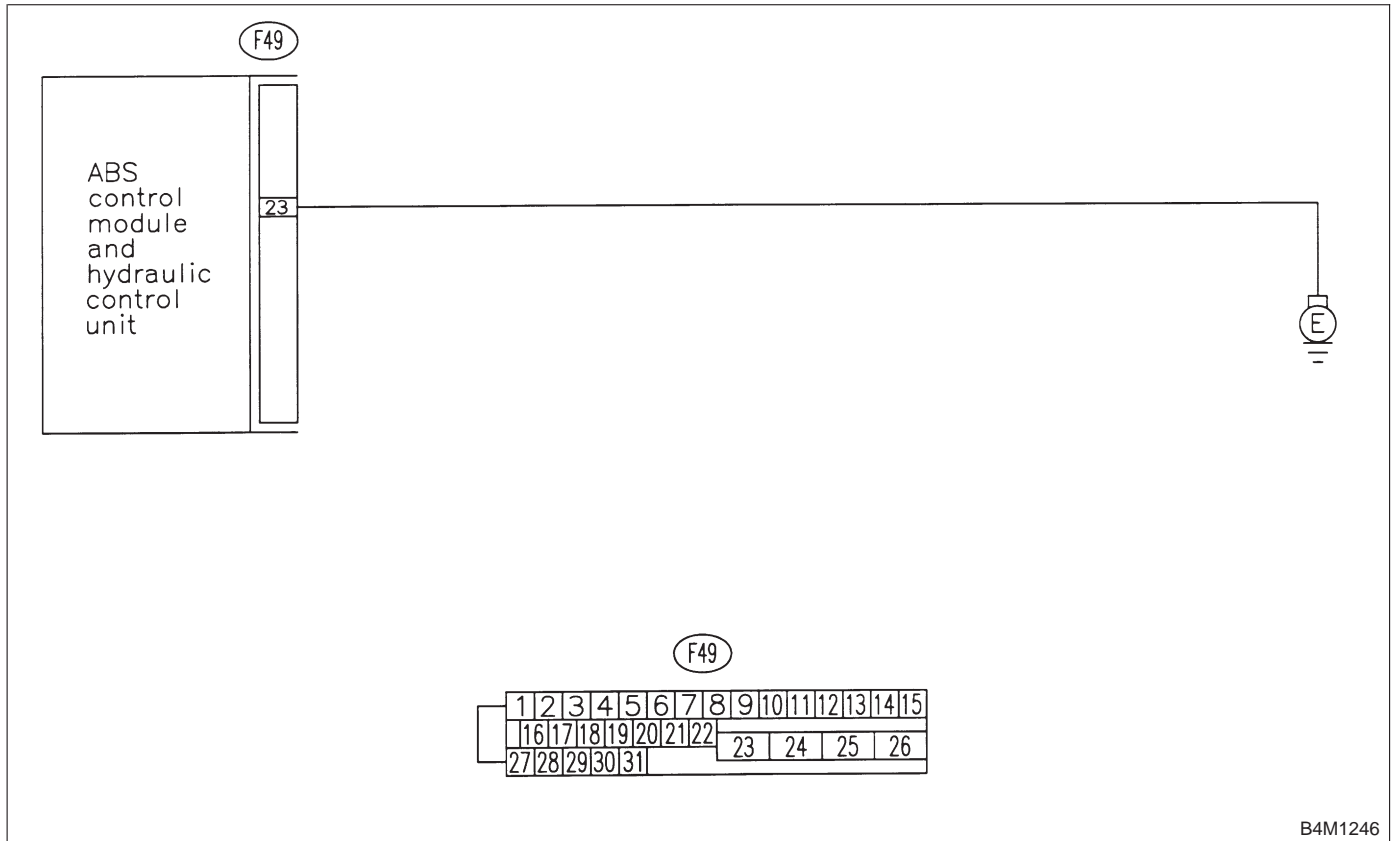

B4M1246

8S1 : CHECK GROUND CIRCUIT OF ABSCM&H/U.

- 1) Turn ignition switch to OFF.
- 2) Disconnect connector from ABSCM&H/U.
- 3) Measure resistance between ABSCM&H/U and chassis ground.

Connector & terminal

(F49) No. 23 — Chassis ground:

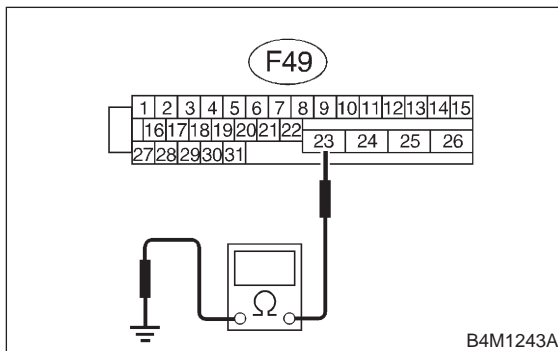

- CHECK** : *Is the resistance less than 0.5 Ω?*
- YES** : Go to step **8S2**.
- NO** : Repair ABSCM&H/U ground harness.

8S2 : CHECK POOR CONTACT IN CONNECTORS.

- CHECK** : *Is there poor contact in connectors between battery, ignition switch and ABSCM&H/U? <Ref. to FOREWORD [T3C1].>*
- YES** : Repair connector.
- NO** : Go to step **8S3**.

8S3 : CHECK SOURCES OF SIGNAL NOISE.

- CHECK** : *Is the car telephone or the wireless transmitter properly installed?*
- YES** : Go to step **8S4**.
- NO** : Properly install the car telephone or the wireless transmitter.

8S4 : CHECK SOURCES OF SIGNAL NOISE.

- CHECK** : *Are noise sources (such as an antenna) installed near the sensor harness?*
- YES** : Install the noise sources apart from the sensor harness.
- NO** : Go to step **8S5**.

8S5 : CHECK ABSCM&H/U.

- 1) Connect all connectors.
 - 2) Erase the memory.
 - 3) Perform inspection mode.
 - 4) Read out the trouble code.
- CHECK** : *Is the same trouble code as in the current diagnosis still being output?*
- YES** : Replace ABSCM&H/U.
- NO** : Go to step **8S6**.

8S6 : CHECK ANY OTHER TROUBLE CODES APPEARANCE.

- CHECK** : *Are other trouble codes being output?*
- YES** : Proceed with the diagnosis corresponding to the trouble code.
- NO** : A temporary poor contact.

T: TROUBLE CODE 42
— SOURCE VOLTAGE IS ABNORMAL. —

DIAGNOSIS:

- Power source voltage of the ABSCM&H/U is low or high.

TROUBLE SYMPTOM:

- ABS does not operate.

WIRING DIAGRAM:

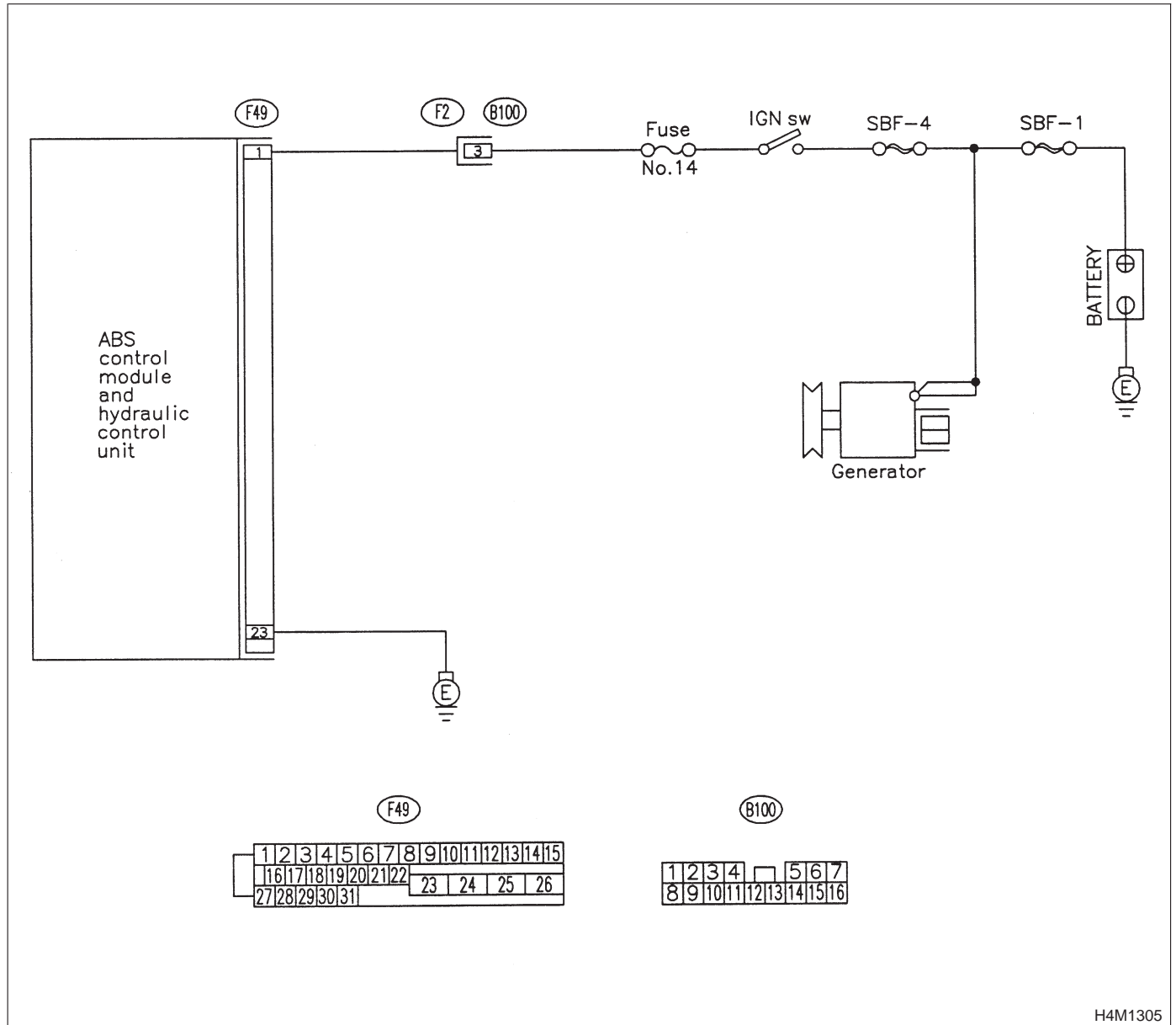

H4M1305

8T1 : CHECK GENERATOR.

- 1) Start engine.
- 2) Idling after warm-up.
- 3) Measure voltage between generator B terminal and chassis ground.

Terminal

Generator B terminal — Chassis ground:

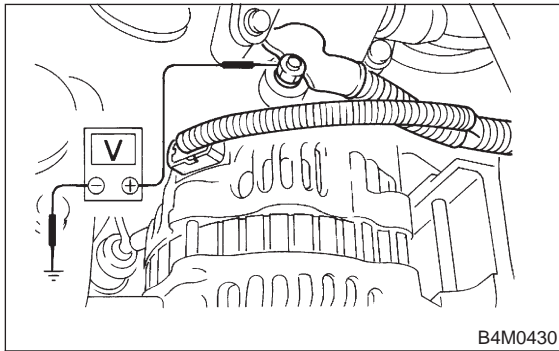

B4M0430

- CHECK** : **Is the voltage between 10 V and 17 V?**
- YES** : Go to step 8T2.
- NO** : Repair generator.

8T2 : CHECK BATTERY TERMINAL.

Turn ignition switch to OFF.

- CHECK** : **Are the positive and negative battery terminals tightly clamped?**
- YES** : Go to step 8T3.
- NO** : Tighten the clamp of terminal.

8T3 : CHECK INPUT VOLTAGE OF ABSCM&H/U.

- 1) Disconnect connector from ABSCM&H/U.
- 2) Run the engine at idle.
- 3) Measure voltage between ABSCM&H/U connector and chassis ground.

Connector & terminal

(F49) No. 1 (+) — Chassis ground (-):

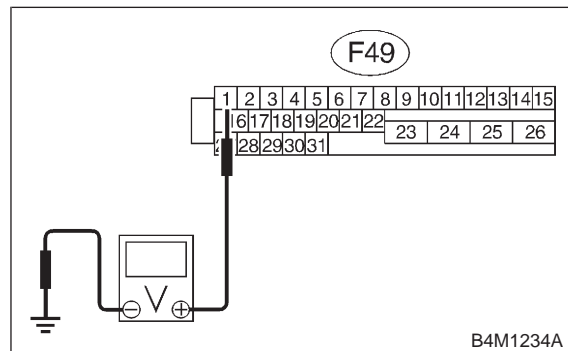

B4M1234A

- CHECK** : **Is the voltage between 10 V and 17 V?**
- YES** : Go to step 8T4.
- NO** : Repair harness connector between battery, ignition switch and ABSCM&H/U.

8T4 : CHECK GROUND CIRCUIT OF ABSCM&H/U.

- 1) Turn ignition switch to OFF.
- 2) Measure resistance between ABSCM&H/U connector and chassis ground.

Connector & terminal

(F49) No. 23 — Chassis ground:

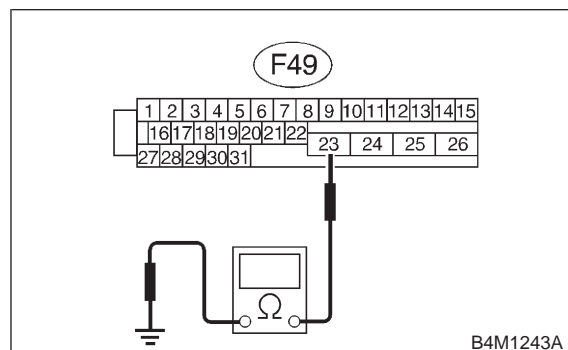

B4M1243A

- CHECK** : **Is the resistance less than 0.5 Ω?**
- YES** : Go to step 8T5.
- NO** : Repair ABSCM&H/U ground harness.

8T5 : CHECK POOR CONTACT IN CONNECTORS.

CHECK : *Is there poor contact in connectors between generator, battery and ABSCM&H/U? <Ref. to FOREWORD [T3C1].>*

YES : Repair connector.

NO : Go to step 8T6.

8T6 : CHECK ABSCM&H/U.

- 1) Connect all connectors.
- 2) Erase the memory.
- 3) Perform inspection mode.
- 4) Read out the trouble code.

CHECK : *Is the same trouble code as in the current diagnosis still being output?*

YES : Replace ABSCM&H/U.

NO : Go to step 8T7.

8T7 : CHECK ANY OTHER TROUBLE CODES APPEARANCE.

CHECK : *Are other trouble codes being output?*

YES : Proceed with the diagnosis corresponding to the trouble code.

NO : A temporary poor contact.

MEMO:

U: TROUBLE CODE 44
— A COMBINATION OF AT CONTROL ABNORMAL —

DIAGNOSIS:

- Combination of AT control faults

TROUBLE SYMPTOM:

- ABS does not operate.

WIRING DIAGRAM:

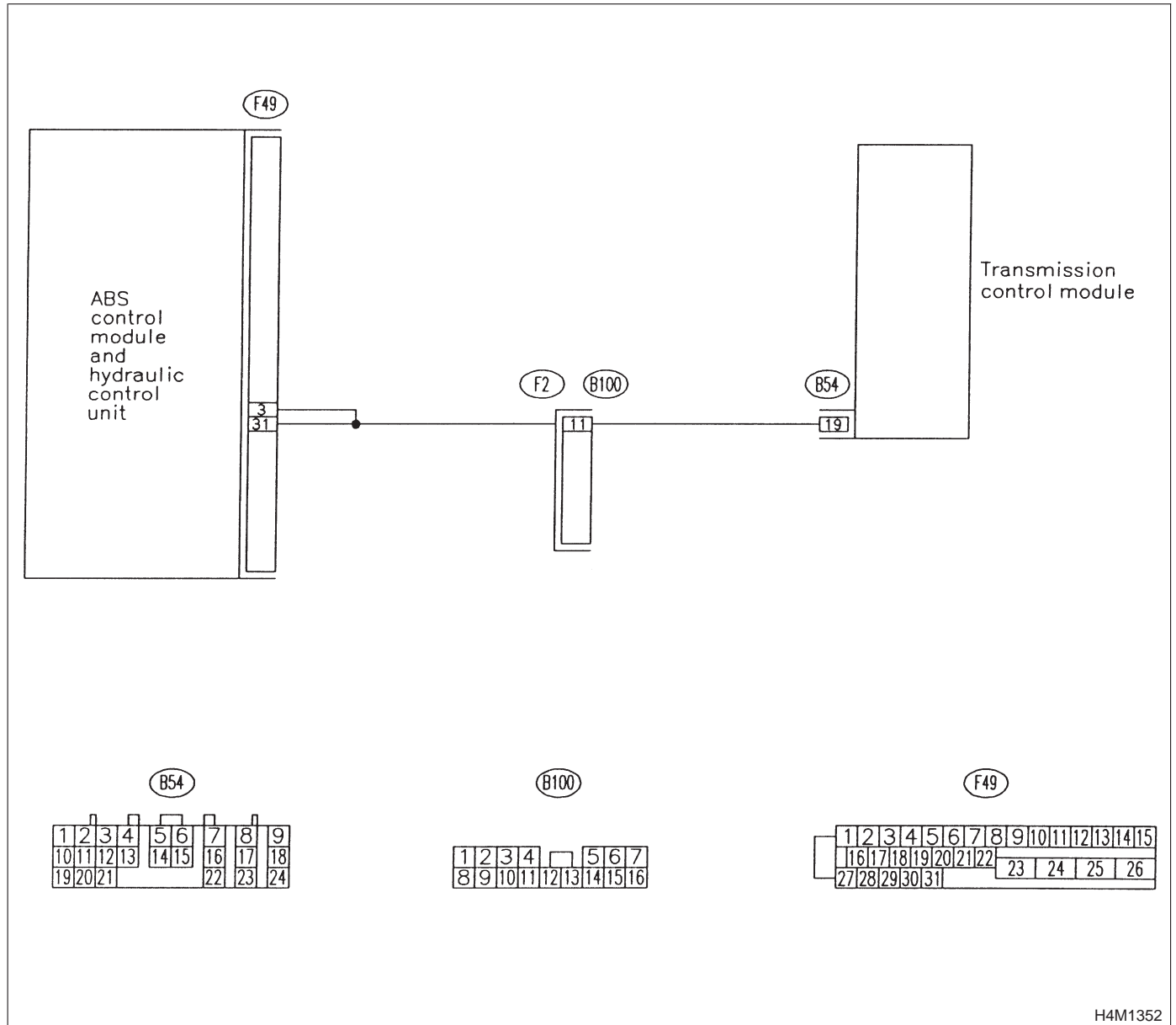

H4M1352

8U1 : CHECK SPECIFICATIONS OF THE ABSCM&H/U.

Check specifications of the mark to the ABSCM&H/U.

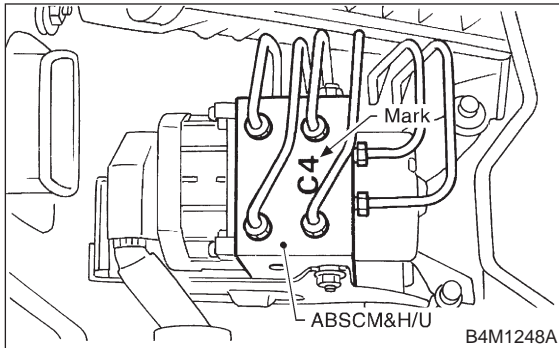

Mark	Model
C5	AWD AT
C6	AWD MT

CHECK : Is an ABSCM&H/U for AT model installed on a MT model?

YES : Replace ABSCM&H/U.

NO : Go to step 8U2.

8U2 : CHECK GROUND SHORT OF HARNESS.

- 1) Turn ignition switch to OFF.
- 2) Disconnect two connectors from TCM.
- 3) Disconnect connector from ABSCM&H/U.
- 4) Measure resistance between ABSCM&H/U connector and chassis ground.

Connector & terminal
(F49) No. 3 — Chassis ground:

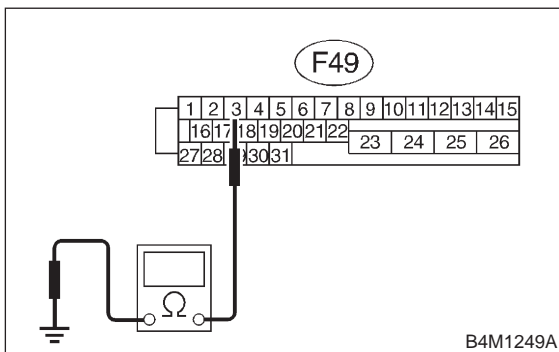

CHECK : Is the resistance more than 1 MΩ?

YES : Go to step 8U3.

NO : Repair harness between TCM and ABSCM&H/U.

8U3 : CHECK BATTERY SHORT OF HARNESS.

Measure voltage between ABSCM&H/U connector and chassis ground.

Connector & terminal

(F49) No. 3 (+) — Chassis ground (-):

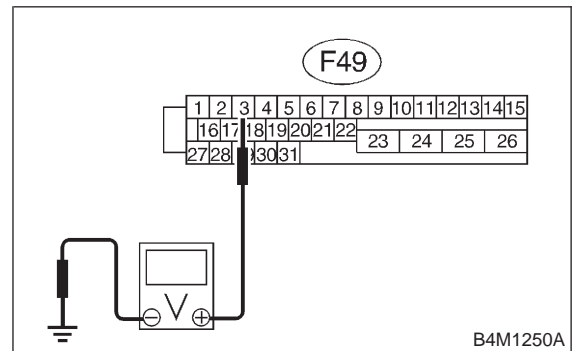

CHECK : Is the voltage less than 1 V?

YES : Go to step 8U4.

NO : Repair harness between TCM and ABSCM&H/U.

8U4 : CHECK BATTERY SHORT OF HARNESS.

- 1) Turn ignition switch to ON.
- 2) Measure voltage between ABSCM&H/U connector and chassis ground.

Connector & terminal

(F49) No. 3 (+) — Chassis ground (-):

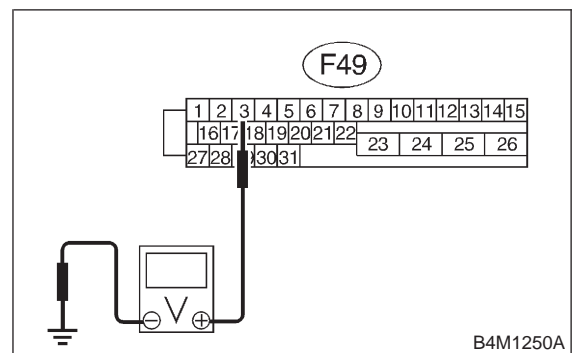

CHECK : Is the voltage less than 1 V?

YES : Go to step 8U5.

NO : Repair harness between TCM and ABSCM&H/U.

8U5 : CHECK TCM.

- 1) Turn ignition switch to OFF.
- 2) Connect all connectors to TCM.
- 3) Turn ignition switch to ON.
- 4) Measure voltage between TCM connector terminal and chassis ground.

Connector & terminal

(B54) No. 19 (+) — Chassis ground (-):

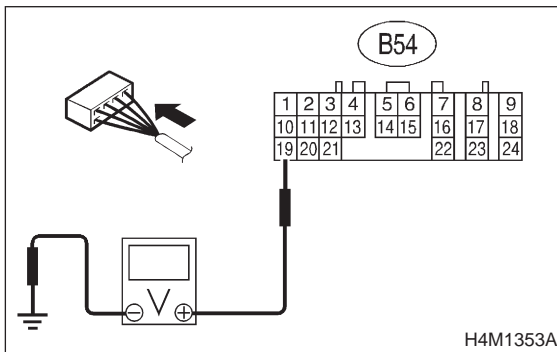

- CHECK** : *Is the voltage between 10 V and 15 V?*
- YES** : Go to step **8U7**.
- NO** : Go to step **8U6**.

8U6 : CHECK AT.

- CHECK** : *Is the AT functioning normally?*
- YES** : Replace TCM.
- NO** : Repair AT.

8U7 : CHECK OPEN CIRCUIT OF HARNESS.

Measure voltage between ABSCM&H/U connector and chassis ground.

Connector & terminal

(F49) No. 3 (+) — Chassis ground (-):
(F49) No. 31 (+) — Chassis ground (-):

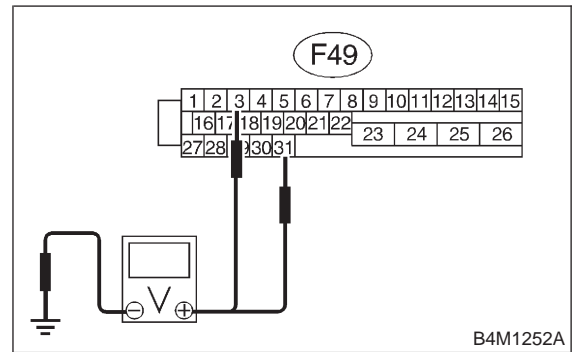

- CHECK** : *Is the voltage between 10 V and 15 V?*
- YES** : Go to step **8U8**.
- NO** : Repair harness/connector between TCM and ABSCM&H/U.

8U8 : CHECK POOR CONTACT IN CONNECTORS.

- CHECK** : *Is there poor contact in connectors between TCM and ABSCM&H/U? <Ref. to FOREWORD [T3C1].>*
- YES** : Repair connector.
- NO** : Go to step **8U9**.

8U9 : CHECK ABSCM&H/U.

- 1) Turn ignition switch to OFF.
- 2) Connect all connectors.
- 3) Erase the memory.
- 4) Perform inspection mode.
- 5) Read out the trouble code.

- CHECK** : *Is the same trouble code as in the current diagnosis still being output?*
- YES** : Replace ABSCM&H/U.
- NO** : Go to step **8U10**.

8U10 : CHECK ANY OTHER TROUBLE CODES APPEARANCE.

- CHECK** : *Are other trouble codes being output?*
- YES** : Proceed with the diagnosis corresponding to the trouble code.
- NO** : A temporary poor contact.

V: TROUBLE CODE 51
— ABNORMAL VALVE RELAY —

DIAGNOSIS:

- Faulty valve relay

TROUBLE SYMPTOM:

- ABS does not operate.

WIRING DIAGRAM:

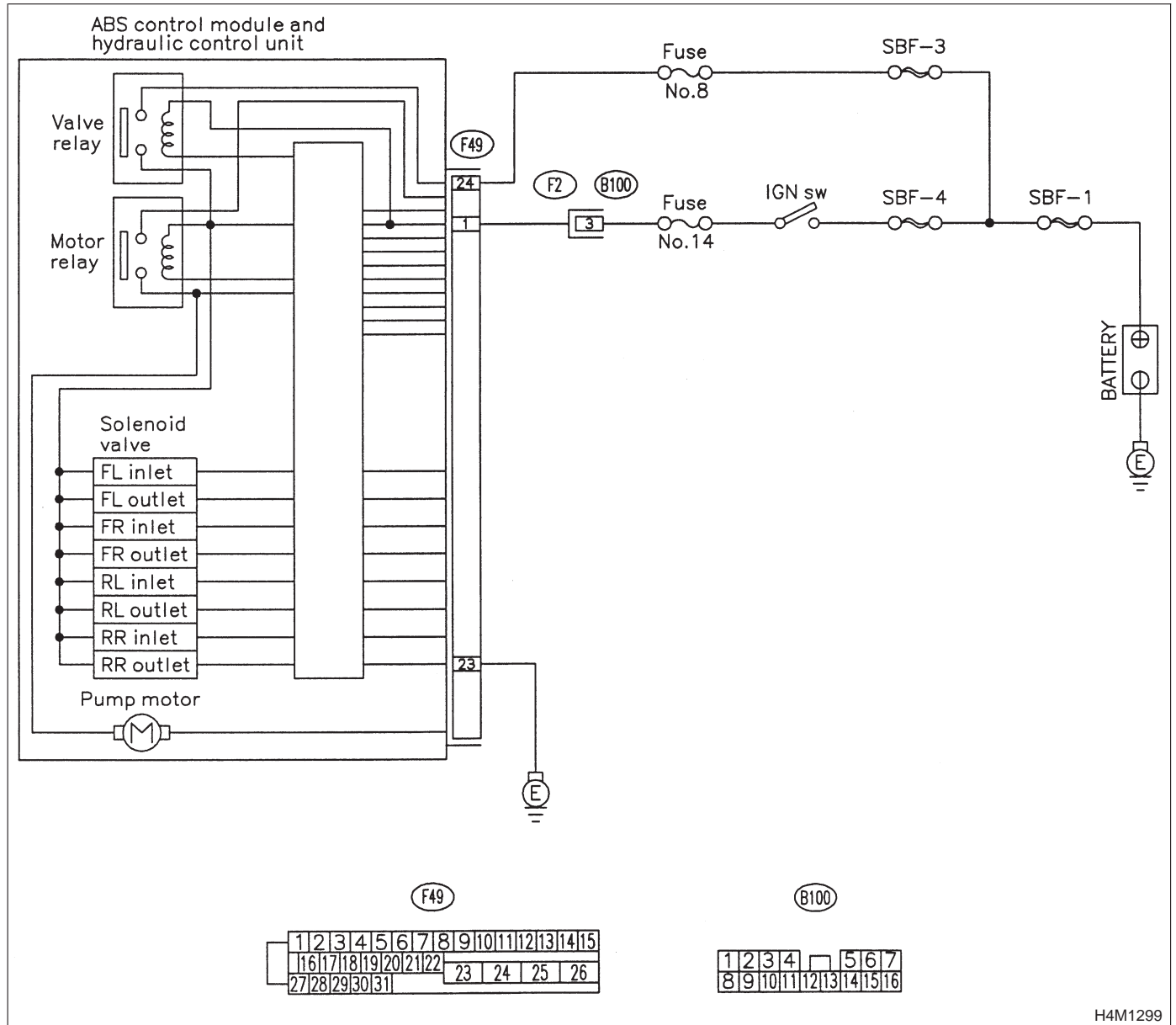

H4M1299

8V1 : CHECK INPUT VOLTAGE OF ABSCM&H/U.

- 1) Turn ignition switch to OFF.
- 2) Disconnect connector from ABSCM&H/U.
- 3) Run the engine at idle.
- 4) Measure voltage between ABSCM&H/U connector and chassis ground.

Connector & terminal

(F49) No. 1 (+) — Chassis ground (-):

(F49) No. 24 (+) — Chassis ground (-):

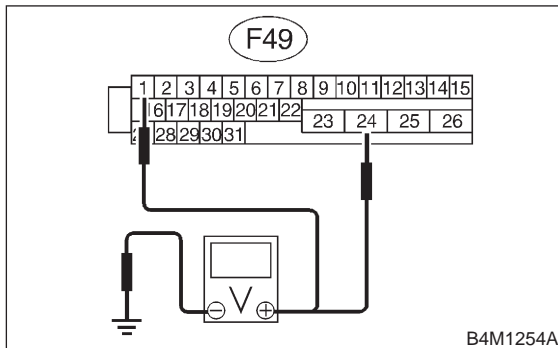

- CHECK** : Is the voltage between 10 V and 15 V?
- YES** : Go to step 8V2.
- NO** : Repair harness connector between battery and ABSCM&H/U.

8V2 : CHECK GROUND CIRCUIT OF ABSCM&H/U.

- 1) Turn ignition switch to OFF.
- 2) Measure resistance between ABSCM&H/U connector and chassis ground.

Connector & terminal

(F49) No. 23 — Chassis ground:

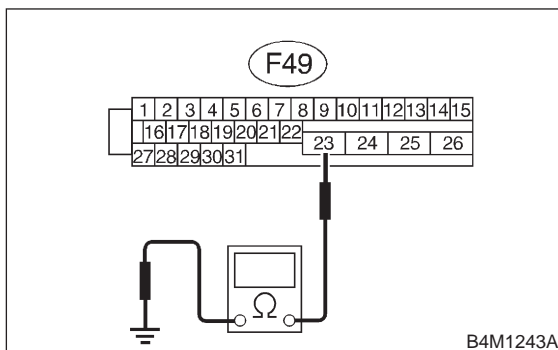

- CHECK** : Is the resistance less than 0.5 Ω?
- YES** : Go to step 8V3.
- NO** : Repair ABSCM&H/U ground harness.

8V3 : CHECK VALVE RELAY IN ABSCM&H/U.

Measure resistance between ABSCM&H/U and terminals.

Terminals

No. 23 (+) — No. 24 (-):

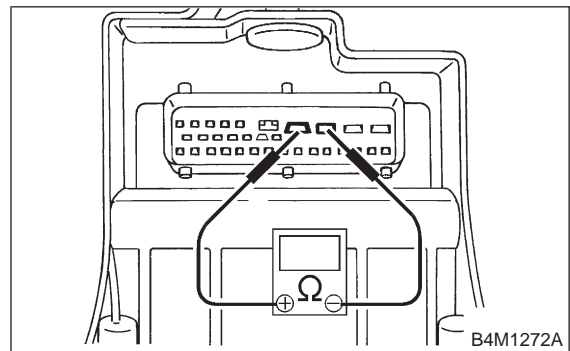

- CHECK** : Is the resistance more than 1 MΩ?
- YES** : Go to step 8V4.
- NO** : Replace ABSCM&H/U.

8V4 : CHECK POOR CONTACT IN CONNECTORS.

- CHECK** : Is there poor contact in connectors between generator, battery and ABSCM&H/U? <Ref. to FOREWORD [T3C1].>
- YES** : Repair connector.
- NO** : Go to step 8V5.

8V5 : CHECK ABSCM&H/U.

- 1) Connect all connectors.
- 2) Erase the memory.
- 3) Perform inspection mode.
- 4) Read out the trouble code.

- CHECK** : Is the same trouble code as in the current diagnosis still being output?
- YES** : Replace ABSCM&H/U.
- NO** : Go to step 8V6.

8V6 : CHECK ANY OTHER TROUBLE CODES APPEARANCE.

- CHECK** : *Are other trouble codes being output?*
- YES** : Proceed with the diagnosis corresponding to the trouble code.
- NO** : A temporary poor contact.

MEMO:

W: TROUBLE CODE 52

— ABNORMAL MOTOR AND/OR MOTOR RELAY —

DIAGNOSIS:

- Faulty motor
- Faulty motor relay
- Faulty harness connector

TROUBLE SYMPTOM:

- ABS does not operate.

WIRING DIAGRAM:

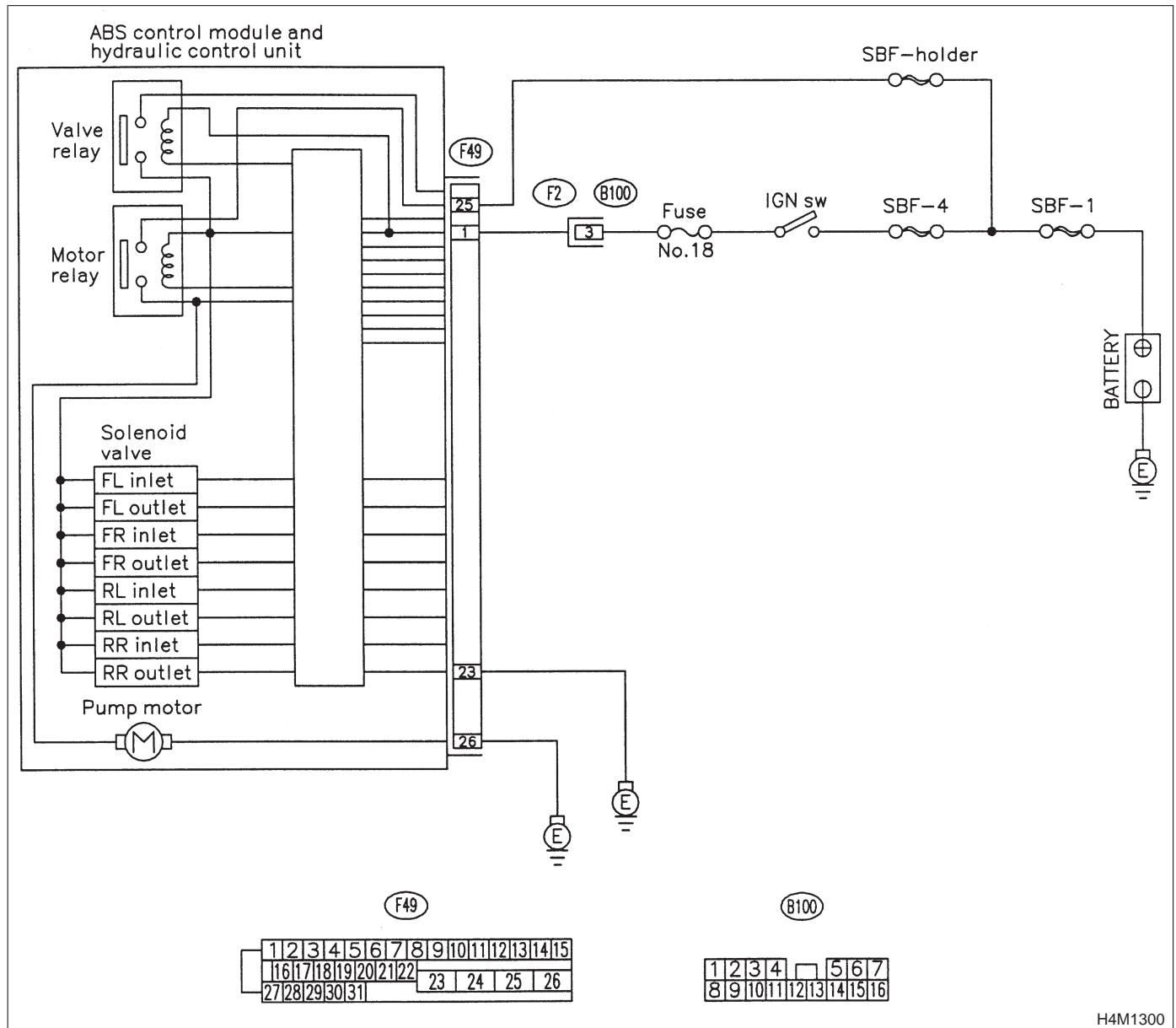

8W1 : CHECK INPUT VOLTAGE OF ABSCM&H/U.

- 1) Turn ignition switch to OFF.
- 2) Disconnect connector from ABSCM&H/U.
- 3) Turn ignition switch to ON.
- 4) Measure voltage between ABSCM&H/U connector and chassis ground.

Connector & terminal

(F49) No. 25 (+) — Chassis ground (-):

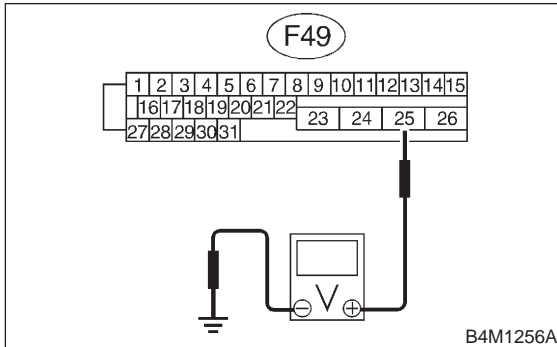

- (CHECK)** : **Is the voltage between 10 V and 15 V?**
- (YES)** : Go to step **8W2**.
- (NO)** : Repair harness/connector between battery and ABSCM&H/U and check fuse SBF-holder.

8W2 : CHECK GROUND CIRCUIT OF MOTOR.

- 1) Turn ignition switch to OFF.
- 2) Measure resistance between ABSCM&H/U connector and chassis ground.

Connector & terminal

(F49) No. 26 — Chassis ground:

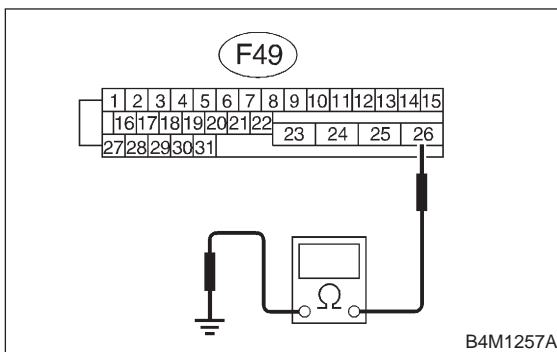

- (CHECK)** : **Is the resistance less than 0.5 Ω?**
- (YES)** : Go to step **8W3**.
- (NO)** : Repair ABSCM&H/U ground harness.

8W3 : CHECK INPUT VOLTAGE OF ABSCM&H/U.

- 1) Run the engine at idle.
- 2) Measure voltage between ABSCM&H/U connector and chassis ground.

Connector & terminal

(F49) No. 1 (+) — Chassis ground (-):

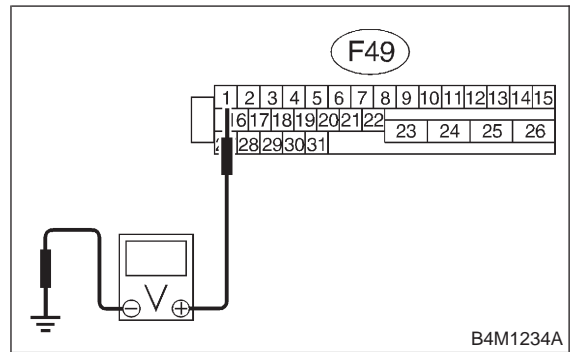

- (CHECK)** : **Is the voltage between 10 V and 15 V?**
- (YES)** : Go to step **8W4**.
- (NO)** : Repair harness connector between battery, ignition switch and ABSCM&H/U.

8W4 : CHECK GROUND CIRCUIT OF ABSCM&H/U.

- 1) Turn ignition switch to OFF.
- 2) Measure resistance between ABSCM&H/U connector and chassis ground.

Connector & terminal

(F49) No. 23 — Chassis ground:

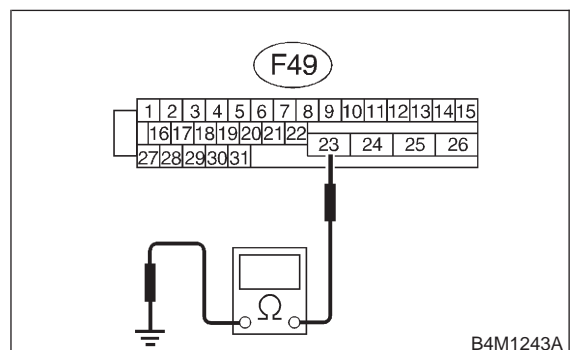

- (CHECK)** : **Is the resistance less than 0.5 Ω?**
- (YES)** : Go to step **8W5**.
- (NO)** : Repair ABSCM&H/U ground harness.

8W5 : CHECK MOTOR OPERATION.

Operate the sequence control. <Ref. to 4-4 [W14D1].>

NOTE:

Use the diagnosis connector to operate the sequence control.

CHECK : *Can motor revolution noise (buzz) be heard when carrying out the sequence control?*

YES : Go to step **8W6**.

NO : Replace ABSCM&H/U.

8W6 : CHECK POOR CONTACT IN CONNECTORS.

Turn ignition switch to OFF.

CHECK : *Is there poor contact in connector between generator, battery and ABSCM&H/U? <Ref. to FOREWORD [T3C1].>*

YES : Repair connector.

NO : Go to step **8W7**.

8W7 : CHECK ABSCM&H/U.

- 1) Connect all connectors.
- 2) Erase the memory.
- 3) Perform inspection mode.
- 4) Read out the trouble code.

CHECK : *Is the same trouble code as in the current diagnosis still being output?*

YES : Replace ABSCM&H/U.

NO : Go to step **8W8**.

8W8 : CHECK ANY OTHER TROUBLE CODES APPEARANCE.

CHECK : *Are other trouble codes being output?*

YES : Proceed with the diagnosis corresponding to the trouble code.

NO : A temporary poor contact.

MEMO:

X: TROUBLE CODE 54
— ABNORMAL STOP LIGHT SWITCH —

DIAGNOSIS:

- Faulty stop light switch

TROUBLE SYMPTOM:

- ABS does not operate.

WIRING DIAGRAM:

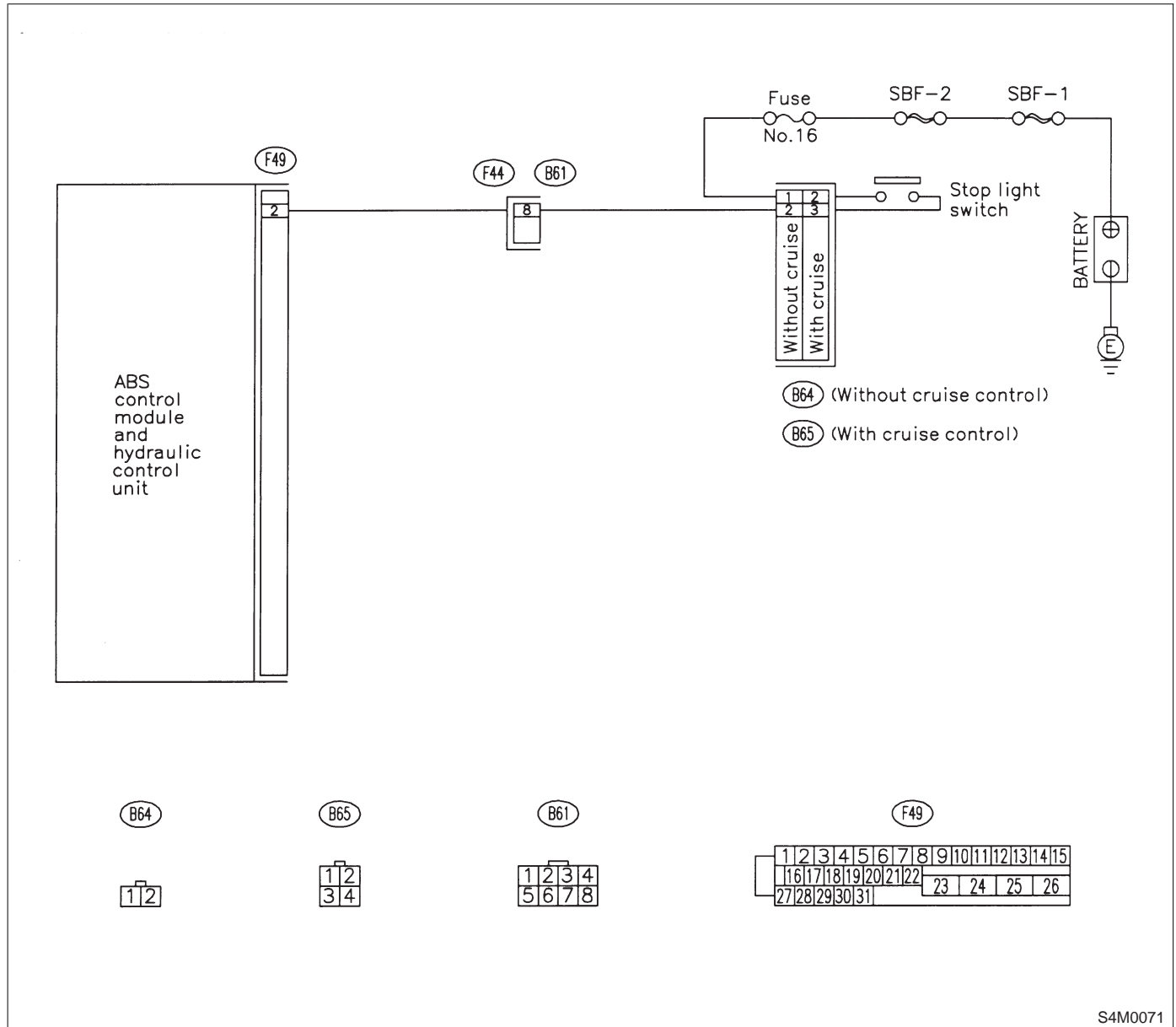

S4M0071

8X1 : CHECK STOP LIGHTS COME ON.

Depress the brake pedal.

- CHECK** : *Do stop lights come on?*
- YES** : Go to step **8X2**.
- NO** : Repair stop lights circuit.

8X2 : CHECK OPEN CIRCUIT IN HARNESS.

- 1) Turn ignition switch to OFF.
- 2) Disconnect connector from ABSCM&H/U.
- 3) Depress brake pedal.
- 4) Measure voltage between ABSCM&H/U connector and chassis ground.

Connector & terminal

(F49) No. 2 (+) — Chassis ground (-):

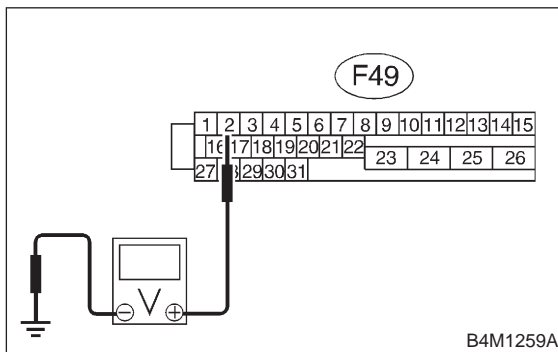

- CHECK** : *Is the voltage between 10 V and 15 V?*
- YES** : Go to step **8X3**.
- NO** : Repair harness between stop light switch and ABSCM&H/U.

8X3 : CHECK POOR CONTACT IN CONNECTORS.

- CHECK** : *Is there poor contact in connector between stop light switch and ABSCM&H/U? <Ref. to FOREWORD [T3C1].>*
- YES** : Repair connector.
- NO** : Go to step **8X4**.

8X4 : CHECK ABSCM&H/U.

- 1) Connect all connectors.
- 2) Erase the memory.
- 3) Perform inspection mode.
- 4) Read out the trouble code.

- CHECK** : *Is the same trouble code as in the current diagnosis still being output?*
- YES** : Replace ABSCM&H/U.
- NO** : Go to step **8X5**.

8X5 : CHECK ANY OTHER TROUBLE CODES APPEARANCE.

- CHECK** : *Are other trouble codes being output?*
- YES** : Proceed with the diagnosis corresponding to the trouble code.
- NO** : A temporary poor contact.

Y: TROUBLE CODE 56
— ABNORMAL G SENSOR OUTPUT VOLTAGE —

DIAGNOSIS:

- Faulty G sensor output voltage

TROUBLE SYMPTOM:

- ABS does not operate.

WIRING DIAGRAM:

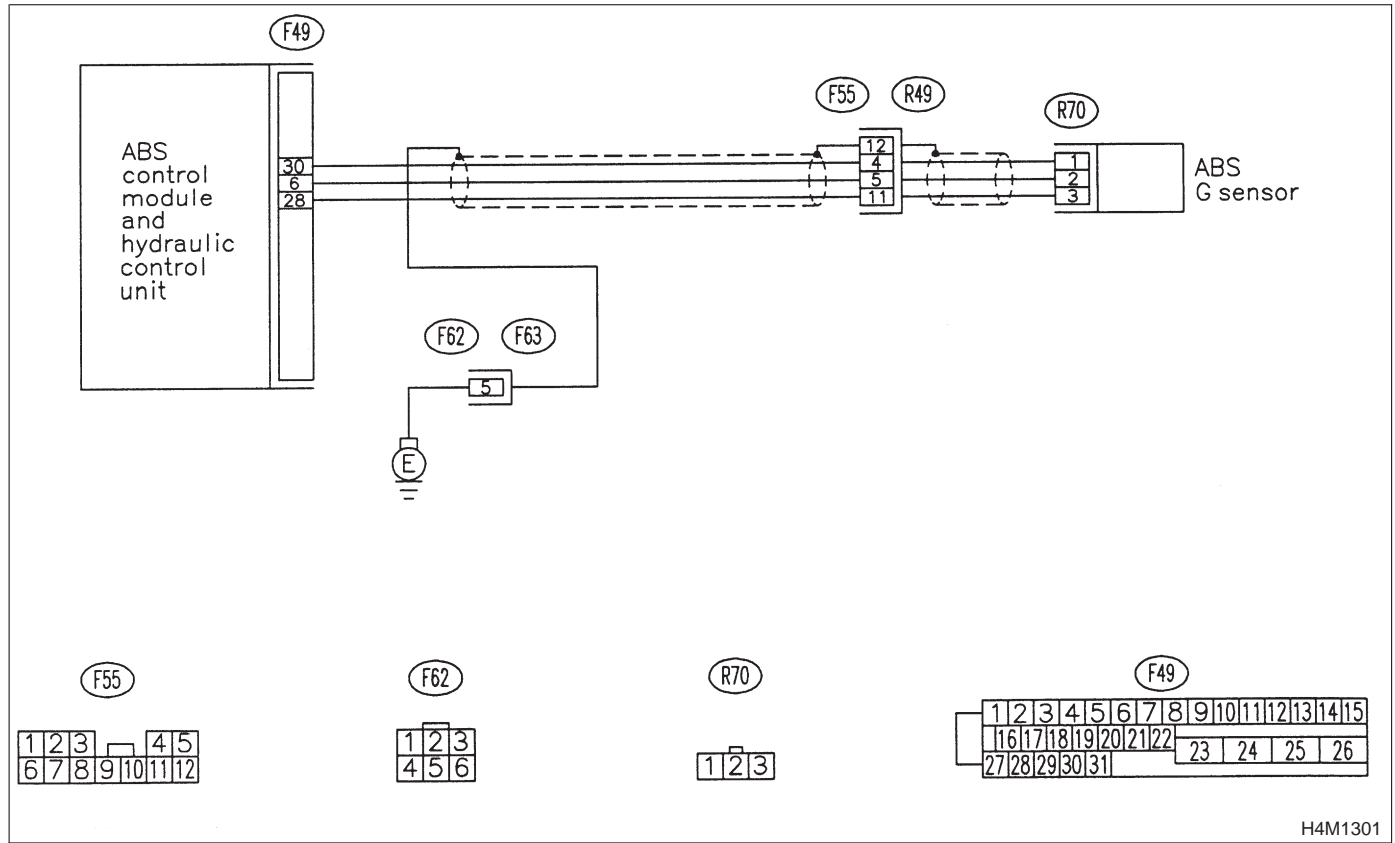

H4M1301

8Y1 : CHECK ALL FOUR WHEELS FOR FREE TURNING.

- CHECK** : *Have the wheels been turned freely such as when the vehicle is lifted up, or operated on a rolling road?*
- YES** : The ABS is normal. Erase the trouble code.
- NO** : Go to step **8Y2**.

8Y2 : CHECK SPECIFICATIONS OF ABSCM&H/U.

Check specifications of the mark to the ABSCM&H/U.

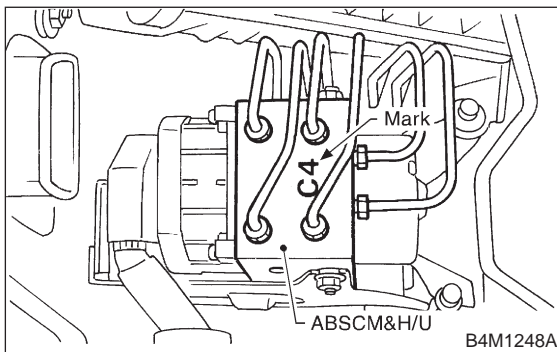

Mark	Model
C5	AWD AT
C6	AWD MT

- CHECK** : *Is an ABSCM for AWD model installed on a FWD model?*
- YES** : Replace ABSCM&H/U.

CAUTION:

Be sure to turn ignition switch to OFF when removing ABSCM&H/U.

- NO** : Go to step **8Y3**.

8Y3 : CHECK INPUT VOLTAGE OF G SENSOR.

- 1) Turn ignition switch to OFF.
- 2) Remove console box.
- 3) Disconnect G sensor from body. (Do not disconnect connector.)
- 4) Turn ignition switch to ON.
- 5) Measure voltage between G sensor connector terminals.

Connector & terminal

(R70) No. 1 (+) — No. 3 (-):

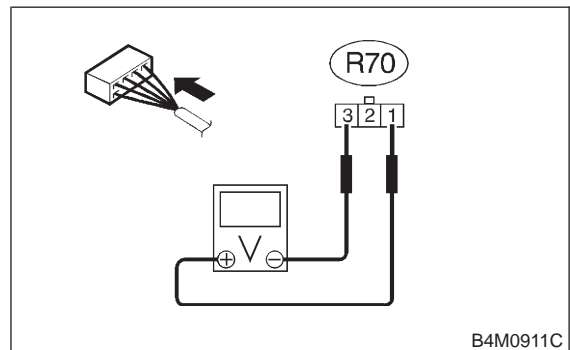

- CHECK** : *Is the voltage between 4.75 and 5.25 V?*
- YES** : Go to step **8Y4**.
- NO** : Repair harness/connector between G sensor and ABSCM&H/U.

8Y4 : CHECK OPEN CIRCUIT IN G SENSOR OUTPUT HARNESS AND GROUND HARNESS.

- 1) Turn ignition switch to OFF.
- 2) Disconnect connector from ABSCM&H/U.
- 3) Measure resistance between ABSCM&H/U connector terminals.

Connector & terminal
(F49) No. 30 — No. 28:

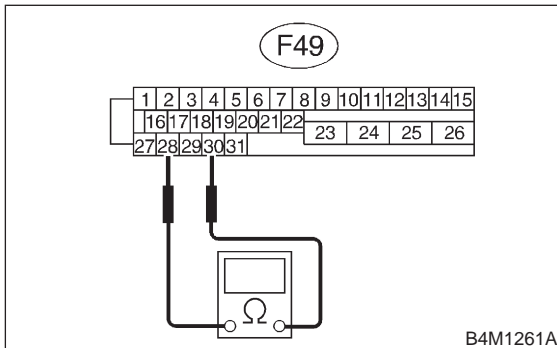

- CHECK** : Is the resistance between 4.3 and 4.9 kΩ?
- YES** : Go to step 8Y5.
- NO** : Repair harness/connector between G sensor and ABSCM&H/U.

8Y5 : CHECK GROUND SHORT IN G SENSOR OUTPUT HARNESS.

- 1) Disconnect connector from G sensor.
- 2) Measure resistance between ABSCM&H/U connector and chassis ground.

Connector & terminal
(F49) No. 6 — Chassis ground:

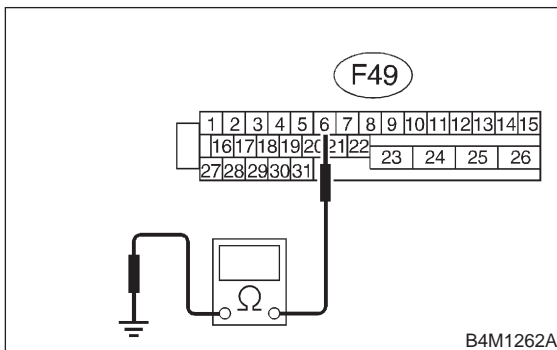

- CHECK** : Is the resistance more than 1 MΩ?
- YES** : Go to step 8Y6.
- NO** : Repair harness between G sensor and ABSCM&H/U.

8Y6 : CHECK BATTERY SHORT OF HARNESS.

Measure voltage between ABSCM&H/U connector and chassis ground.

Connector & terminal
(F49) No. 6 (+) — Chassis ground (-):

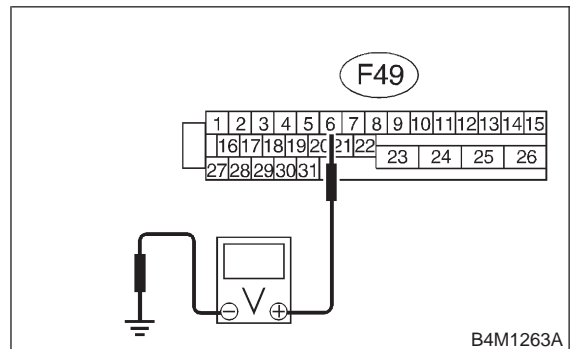

- CHECK** : Is the voltage less than 1 V?
- YES** : Go to step 8Y7.
- NO** : Repair harness between G sensor and ABSCM&H/U.

8Y7 : CHECK BATTERY SHORT OF HARNESS.

- 1) Turn ignition switch to ON.
- 2) Measure voltage between ABSCM&H/U connector and chassis ground.

Connector & terminal
(F49) No. 6 (+) — Chassis ground (-):

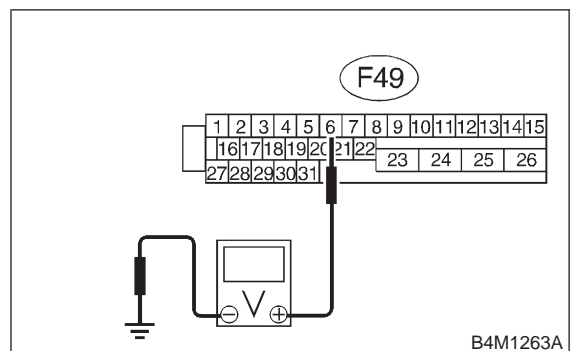

- CHECK** : Is the voltage less than 1 V?
- YES** : Go to step 8Y8.
- NO** : Repair harness between G sensor and ABSCM&H/U.

8Y8 : CHECK GROUND SHORT OF HARNESS.

Measure resistance between ABSCM&H/U connector and chassis ground.

Connector & terminal

(F49) No. 28 — Chassis ground:

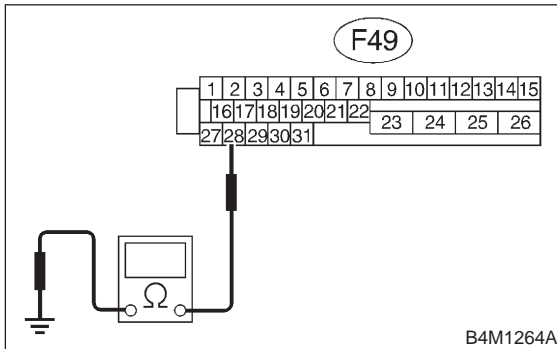

CHECK : *Is the resistance more than 1 MΩ?*

YES : Go to step 8Y9.

NO : Repair harness between G sensor and ABSCM&H/U.
Replace ABSCM&H/U.

8Y9 : CHECK G SENSOR.

- 1) Turn ignition switch to OFF.
- 2) Remove G sensor from vehicle.
- 3) Connect connector to G sensor.
- 4) Connect connector to ABSCM&H/U.
- 5) Turn ignition switch to ON.
- 6) Measure voltage between G sensor connector terminals.

Connector & terminal

(R70) No. 2 (+) — No. 3 (-):

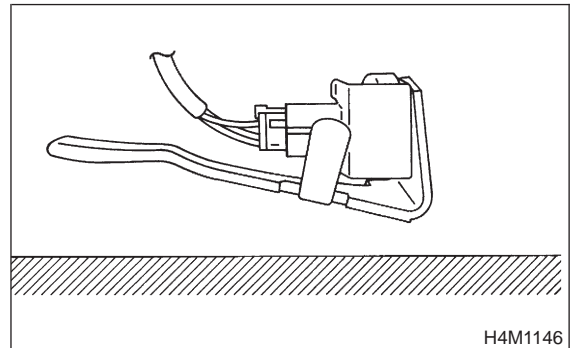
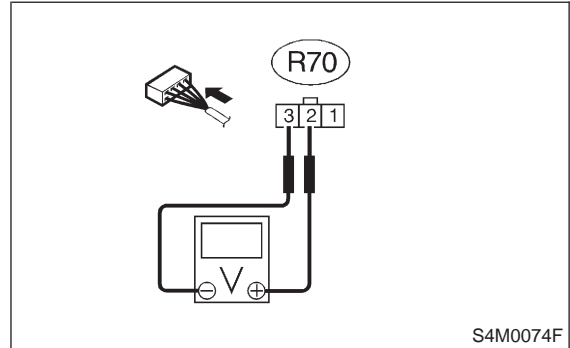

CHECK : *Is the voltage between 2.1 and 2.5 V when G sensor is horizontal?*

YES : Go to step 8Y10.

NO : Replace G sensor.

8Y10 : CHECK G SENSOR.

Measure voltage between G sensor connector terminals.

Connector & terminal

(R70) No. 2 (+) — No. 3 (-):

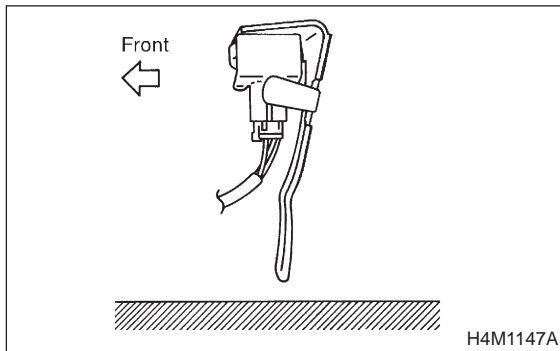

CHECK : *Is the voltage between 3.7 and 4.1 V when G sensor is inclined forwards to 90°?*

YES : Go to step 8Y11.

NO : Replace G sensor.

8Y11 : CHECK G SENSOR.

Measure voltage between G sensor connector terminals.

Connector & terminal

(R70) No. 2 (+) — No. 3 (-):

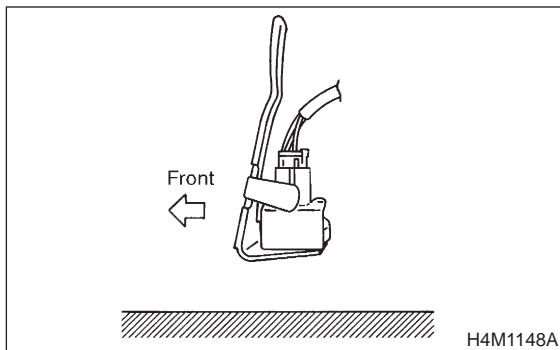

CHECK : *Is the voltage between 0.5 and 0.9 V when G sensor is inclined backwards to 90°?*

YES : Go to step 8Y12.

NO : Replace G sensor.

8Y12 : CHECK POOR CONTACT IN CONNECTORS.

CHECK : *Is there poor contact in connector between ABSCM&H/U and G sensor? <Ref. to FOREWORD [T3C1].>*

YES : Repair connector.

NO : Go to step 8Y13.

8Y13 : CHECK ABSCM&H/U.

- 1) Connect all connectors.
- 2) Erase the memory.
- 3) Perform inspection mode.
- 4) Read out the trouble code.

CHECK : *Is the same trouble code as in the current diagnosis still being output?*

YES : Replace ABSCM&H/U.

NO : Go to step 8Y14.

8Y14 : CHECK ANY OTHER TROUBLE CODES APPEARANCE.

CHECK : *Are other trouble codes being output?*

YES : Proceed with the diagnosis corresponding to the trouble code.

NO : A temporary poor contact.

MEMO:

9. Select Monitor Function Mode

Applicable cartridge of select monitor: No. 24082AA090

NOTE:

For basic handling of the select monitor, refer to its Operation Manual.

A: LIST OF FUNCTION MODE

1. ANALOG DATA ARE DISPLAYED.

Display screen	Contents to be monitored
FR wheel speed	Wheel speed detected by the Front Right ABS sensor is displayed in km/h or mile/h.
FL wheel speed	Wheel speed detected by the Front Left ABS sensor is displayed in km/h or mile/h.
RR wheel speed	Wheel speed detected by the Rear Right ABS sensor is displayed in km/h or mile/h.
RL wheel speed	Wheel speed detected by the Rear Left ABS sensor is displayed in km/h or mile/h.
Stop light switch	Stop light switch monitor voltage is displayed.
G sensor output voltage	Refers to vehicle acceleration detecting by the analog G sensor. It appears on the select monitor display in volts.

2. ON/OFF DATA ARE DISPLAYED.

Display screen	Contents to be monitored
Stop light switch	Stop light switch signal
Valve relay signal	Valve relay signal
Motor relay signal	Motor relay signal
ABS signal to TCM	ABS operation signal from ABS control module to TCM
ABS warning light	ABS warning light
Valve relay monitor	Valve relay operation monitor signal
Motor relay monitor	Motor relay operation monitor signal
CCM signal	ABS operation signal from ABS control module to TCM

3. TROUBLE CODES ARE DISPLAYED.

A maximum of 3 trouble codes are displayed in order of occurrence.

- If a particular trouble code is not properly stored in memory (due to a drop in ABSCM&H/U power supply, etc.) when a problem occurs, the trouble code, followed by a question mark "?", appears on the select monitor display. This shows it may be an unreliable reading.

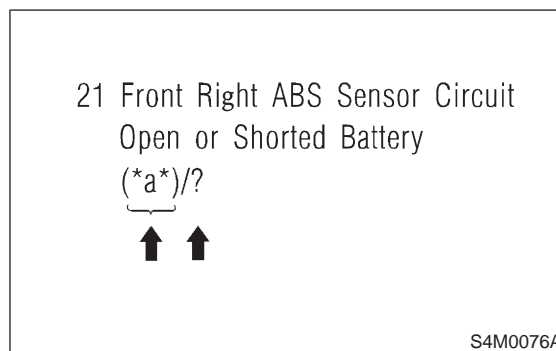

- *a* refers to the troubles in order of occurrence (Latest, Old, Older and Reference).

Display screen	Contents to be monitored
Latest	The most recent trouble code appears on the select monitor display.
Old	The second most recent trouble code appears on the select monitor display.
Older	The third most recent trouble code appears on the select monitor display.
Reference	A specified period of time preceding trouble code appears on the select monitor display.

4. CLEAR MEMORY

Display screen	Contents to be monitored
Clear memory?	Function of clearing trouble code and freeze frame data.

5. ABS SEQUENCE CONTROL

Display screen	Contents to be monitored	Index No.
ABS sequence control	Perform ABS sequence control by operating valve and pump motor sequentially.	<Ref. to 4-4 [W14D0].>

6. FREEZE FRAME DATA

NOTE:

- Data stored at the time of trouble occurrence is shown on display.
- Each time trouble occurs, the latest information is stored in the freeze frame data in memory.
- If freeze frame data is not properly stored in memory (due to a drop in ABSCM power supply, etc.), a trouble code, preceded by a question mark “?”, appears on the select monitor display. This shows it may be an unreliable reading.

Display screen	Contents to be monitored
FR wheel speed	Wheel speed detected by the Front Right ABS sensor is displayed in km/h or mile/h.
FL wheel speed	Wheel speed detected by the Front Left ABS sensor is displayed in km/h or mile/h.
RR wheel speed	Wheel speed detected by the Rear Right ABS sensor is displayed in km/h or mile/h.
RL wheel speed	Wheel speed detected by the Rear Left ABS sensor is displayed in km/h or mile/h.
ABSCM power voltage	Power (in volts) supplied to ABSCM&H/U appears on the select monitor display.
G sensor output voltage	Refers to vehicle acceleration detected by the analog G sensor. It appears on the select monitor display in volts.
Motor relay monitor	Motor relay operation monitor signal
Stop light switch	Stop light switch signal
ABS signal to TCM	ABS operation signal from ABS control module to TCM
ABS-AT control	ABS operation signal from ABS control module to TCM
ABS operation signal	ABS operation signal

10. Diagnostics Chart with Select Monitor

A: BASIC DIAGNOSTIC CHART

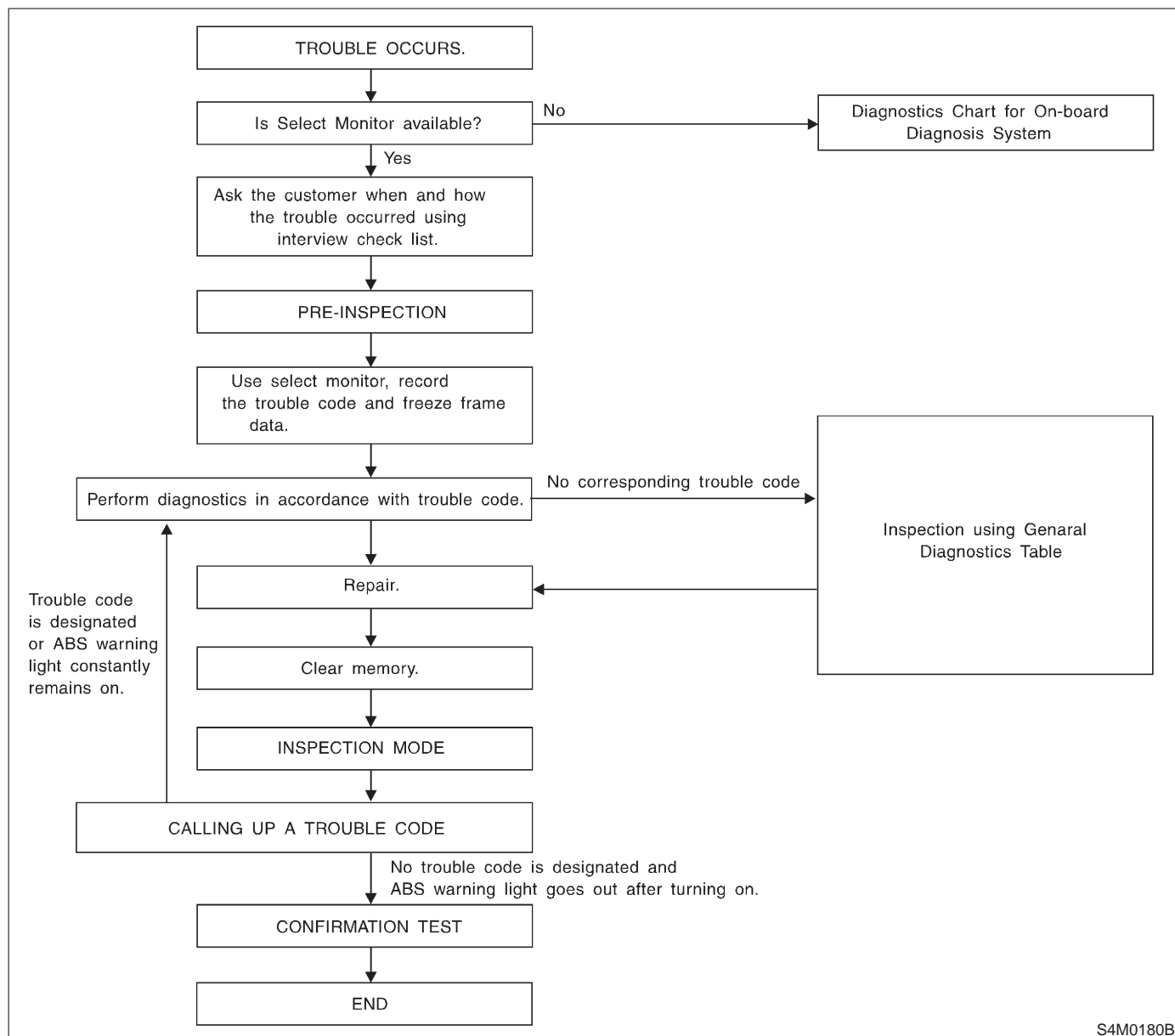

CAUTION:

Remove foreign matter (dust, water, etc.) from the ABSCM&H/U connector during removal and installation.

NOTE:

- To check harness for broken wires or short circuits, shake it while holding it or the connector.
- Check list for interview. <Ref. to 4-4 [T6B0].>

B: LIST OF DIAGNOSTIC TROUBLE CODE

Code	Display screen	Contents of diagnosis	Index No.
—	Communication for initializing impossible	Select monitor communication failure	<Ref. to 4-4 [T10C0].>
—	No trouble code	Although no trouble code appears on the select monitor display, the ABS warning light remains on.	<Ref. to 4-4 [T10D0].>
21	Open or short circuit in front right ABS sensor circuit	Open or short circuit in front right ABS sensor circuit	<Ref. to 4-4 [T10E0].>
22	Front right ABS sensor abnormal signal	Front right ABS sensor abnormal signal	<Ref. to 4-4 [T10I0].>
23	Open or short circuit in front left ABS sensor circuit	Open or short circuit in front left ABS sensor circuit	<Ref. to 4-4 [T10F0].>
24	Front left ABS sensor abnormal signal	Front left ABS sensor abnormal signal	<Ref. to 4-4 [T10J0].>
25	Open or short circuit in rear right ABS sensor circuit	Open or short circuit in rear right ABS sensor circuit	<Ref. to 4-4 [T10G0].>
26	Rear right ABS sensor abnormal signal	Rear right ABS sensor abnormal signal	<Ref. to 4-4 [T10K0].>
27	Open or short circuit in rear left ABS sensor circuit	Open or short circuit in rear left ABS sensor circuit	<Ref. to 4-4 [T10H0].>
28	Rear left ABS sensor abnormal signal	Rear left ABS sensor abnormal signal	<Ref. to 4-4 [T10L0].>
29	Abnormal ABS sensor signal on any one of four sensor	Abnormal ABS sensor signal on any one of four	<Ref. to 4-4 [T10M0].>
31	Front right inlet valve malfunction	Front right inlet valve malfunction	<Ref. to 4-4 [T10N0].>
32	Front right outlet valve malfunction	Front right outlet valve malfunction	<Ref. to 4-4 [T10R0].>
33	Front left inlet valve malfunction	Front left inlet valve malfunction	<Ref. to 4-4 [T10O0].>
34	Front left outlet valve malfunction	Front left outlet valve malfunction	<Ref. to 4-4 [T10S0].>
35	Rear right inlet valve malfunction	Rear right inlet valve malfunction	<Ref. to 4-4 [T10P0].>
36	Rear right outlet valve malfunction	Rear right outlet valve malfunction	<Ref. to 4-4 [T10T0].>
37	Rear left inlet valve malfunction	Rear left inlet valve malfunction	<Ref. to 4-4 [T10Q0].>
38	Rear left outlet valve malfunction	Rear left outlet valve malfunction	<Ref. to 4-4 [T10U0].>
41	ABS control module malfunction	ABS control module and hydraulic control unit malfunction	<Ref. to 4-4 [T10V0].>
42	Power supply voltage too low	Power supply voltage too low	<Ref. to 4-4 [T10W0].>
42	Power supply voltage too high	Power supply voltage too high	<Ref. to 4-4 [T10X0].>
44	ABS-AT control (Non Controlled)	ABS-AT control (Non Controlled)	<Ref. to 4-4 [T10Y0].>
44	ABS-AT control (Controlled)	ABS-AT control (Controlled)	<Ref. to 4-4 [T10Z0].>
51	Valve relay malfunction	Valve relay malfunction	<Ref. to 4-4 [T10AA0].>
51	Valve relay ON failure	Valve relay ON failure	<Ref. to 4-4 [T10AB0].>
52	Open circuit in motor relay circuit	Open circuit in motor relay circuit	<Ref. to 4-4 [T10AC0].>
52	Motor relay ON failure	Motor relay ON failure	<Ref. to 4-4 [T10AD0].>
52	Motor malfunction	Motor malfunction	<Ref. to 4-4 [T10AE0].>
54	Stop light switch signal circuit malfunction	Stop light switch signal circuit malfunction	<Ref. to 4-4 [T10AF0].>
56	Open or short circuit in G sensor circuit	Open or short circuit in G sensor circuit	<Ref. to 4-4 [T10AG0].>
56	Battery short in G sensor circuit	Battery short in G sensor circuit	<Ref. to 4-4 [T10AH0].>
56	Abnormal G sensor high μ output	Abnormal G sensor high μ output	<Ref. to 4-4 [T10AI0].>
56	Detection of G sensor stick	Detection of G sensor stick	<Ref. to 4-4 [T10AJ0].>

NOTE:

High μ means high friction coefficient against road surface.

C: COMMUNICATION FOR INITIALIZING IMPOSSIBLE
— SELECT MONITOR COMMUNICATION FAILURE —

DIAGNOSIS:

- Faulty harness connector

TROUBLE SYMPTOM:

- ABS warning light remains on.

WIRING DIAGRAM:

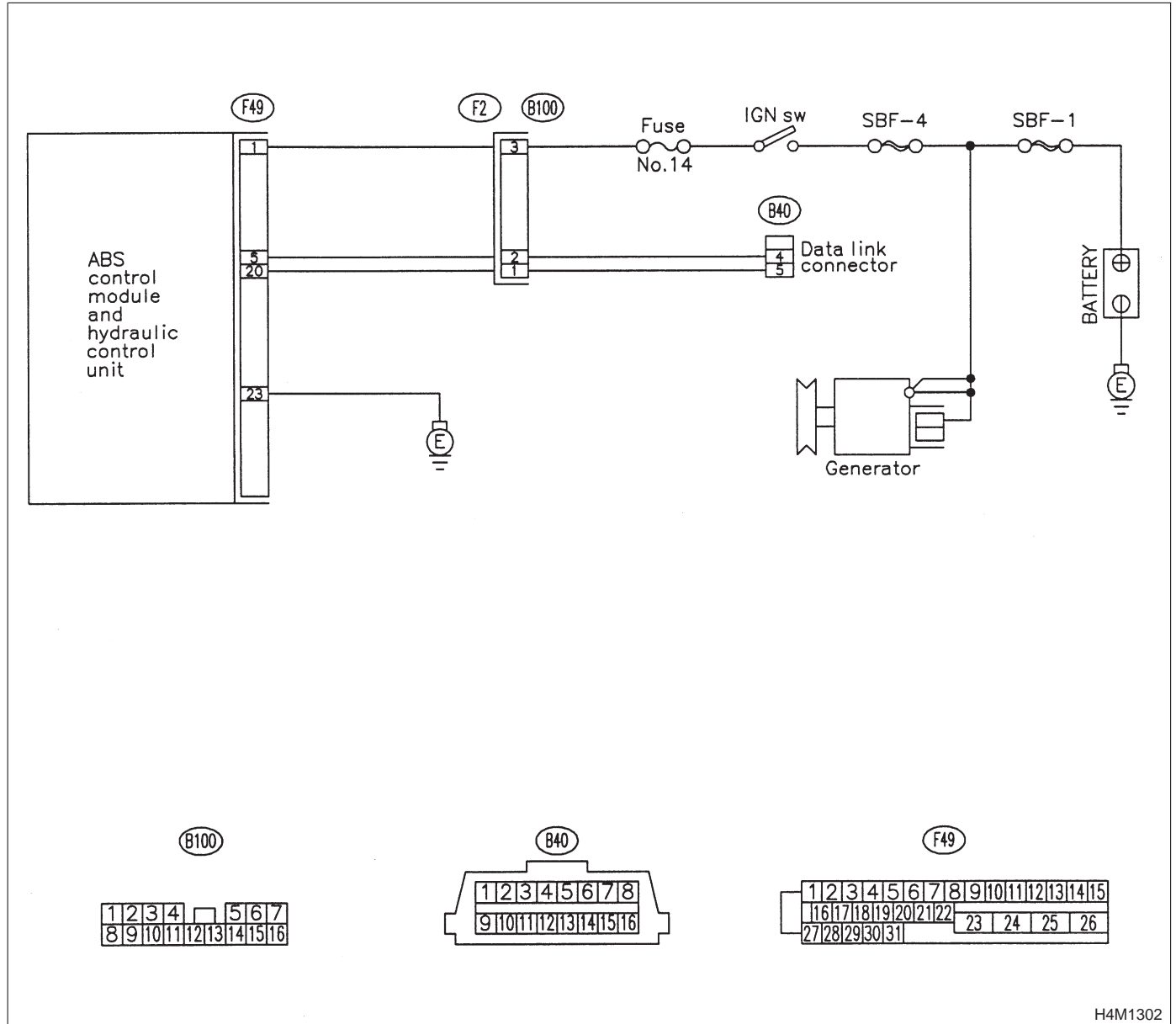

H4M1302

10C1 : CHECK IGNITION SWITCH.

- CHECK** : *Is ignition switch ON?*
- YES** : Go to step **10C2**.
- NO** : Turn ignition switch ON, and select ABS/TCS mode using the select monitor.

10C2 : CHECK GENERATOR.

- 1) Start the engine.
- 2) Idle the engine.
- 3) Measure voltage between generator and chassis ground.

Terminal

Generator B terminal (+) — Chassis ground (-):

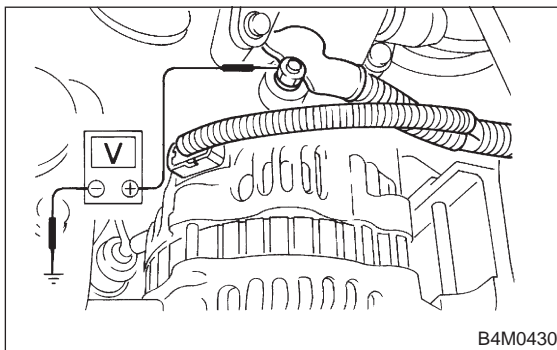

- CHECK** : *Is the voltage between 10 and 15 V?*
- YES** : Go to step **10C3**.
- NO** : Repair generator.

10C3 : CHECK BATTERY TERMINAL.

Turn ignition switch to OFF.

- CHECK** : *Is there poor contact at battery terminal?*
- YES** : Repair battery terminal.
- NO** : Go to step **10C4**.

10C4 : CHECK COMMUNICATION OF SELECT MONITOR.

Using the select monitor, check whether communication to other system (such as engine, AT, etc.) can be executed normally.

- CHECK** : *Are the name and year of the system displayed on the select monitor?*
- YES** : Go to step **10C5**.
- NO** : Repair select monitor communication cable and connector.

10C5 : CHECK INSTALLATION OF ABSCM&H/U CONNECTOR.

Turn ignition switch to OFF.

- CHECK** : *Is ABSCM&H/U connector inserted into ABSCM&H/U until the clamp locks onto it?*
- YES** : Go to step **10C6**.
- NO** : Insert ABSCM&H/U connector into ABSCM&H/U until the clamp locks onto it.

10C6 : CHECK POWER SUPPLY OF ABSCM&H/U.

- 1) Disconnect connector from ABSCM&H/U.
- 2) Start engine.
- 3) Idle the engine.
- 4) Measure voltage between ABSCM&H/U connector and chassis ground.

Connector & terminal

(F49) No. 1 (+) — Chassis ground (-):

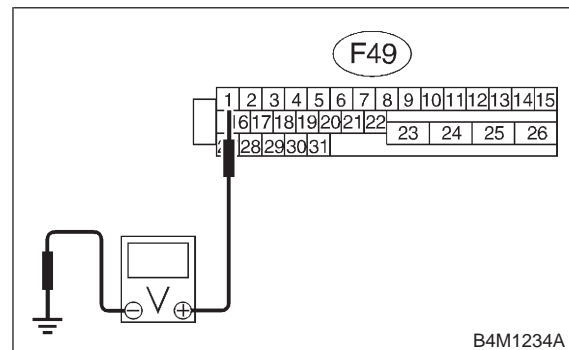

- CHECK** : *Is the voltage between 10 and 15 V?*
- YES** : Go to step **10C7**.
- NO** : Repair ABSCM&H/U power supply circuit.

10C7 : CHECK GROUND CIRCUIT OF ABSCM&H/U.

- 1) Turn ignition switch to OFF.
- 2) Measure resistance between ABSCM&H/U connector and chassis ground.

Connector & terminal

(F49) No. 23 — Chassis ground:

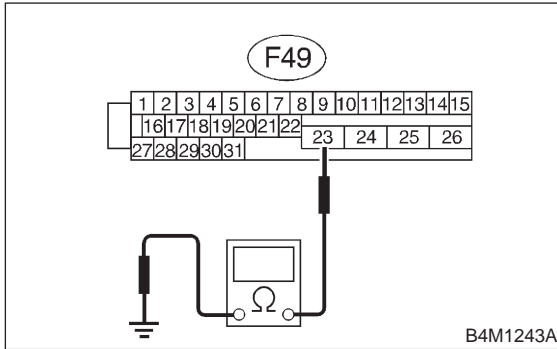

- CHECK** : *Is the resistance less than 0.5 Ω?*
- YES** : Repair harness/connector between ABSCM&H/U and select monitor.
- NO** : Go to step **10C8**.

10C8 : CHECK HARNESS/CONNECTOR BETWEEN ABSCM&H/U AND DATA LINK CONNECTOR.

- 1) Turn ignition switch OFF.
- 2) Measure resistance between ABSCM&H/U connector and data link connector.

Connector & terminal

(F49) No. 20 — (B40) No. 5:

(F49) No. 5 — (B40) No. 4:

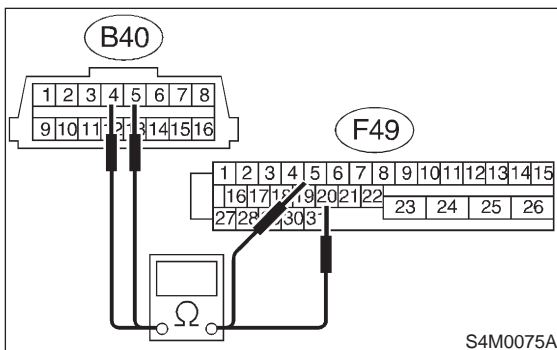

- CHECK** : *Is the resistance less than 0.5 Ω?*
- YES** : Repair harness and connector between ABSCM&H/U and data link connector.
- NO** : Go to step **10C9**.

10C9 : CHECK POOR CONTACT IN CONNECTORS.

- CHECK** : *Is there poor contact in connectors between ABSCM&H/U and data link connector? <Ref. to FOREWORD [T3C1].>*
- YES** : Repair connector.
- NO** : Replace ABSCM&H/U.

MEMO:

D: NO TROUBLE CODE

— ALTHOUGH NO TROUBLE CODE APPEARS ON THE SELECT MONITOR DISPLAY, THE ABS WARNING LIGHT REMAINS ON. —

DIAGNOSIS:

- ABS warning light circuit is shorted.

TROUBLE SYMPTOM:

- ABS warning light remains on.
- NO TROUBLE CODE displayed on the select monitor.

NOTE:

When the ABS warning light is OFF and "NO TROUBLE CODE" is displayed on the select monitor, the system is in normal condition.

WIRING DIAGRAM:

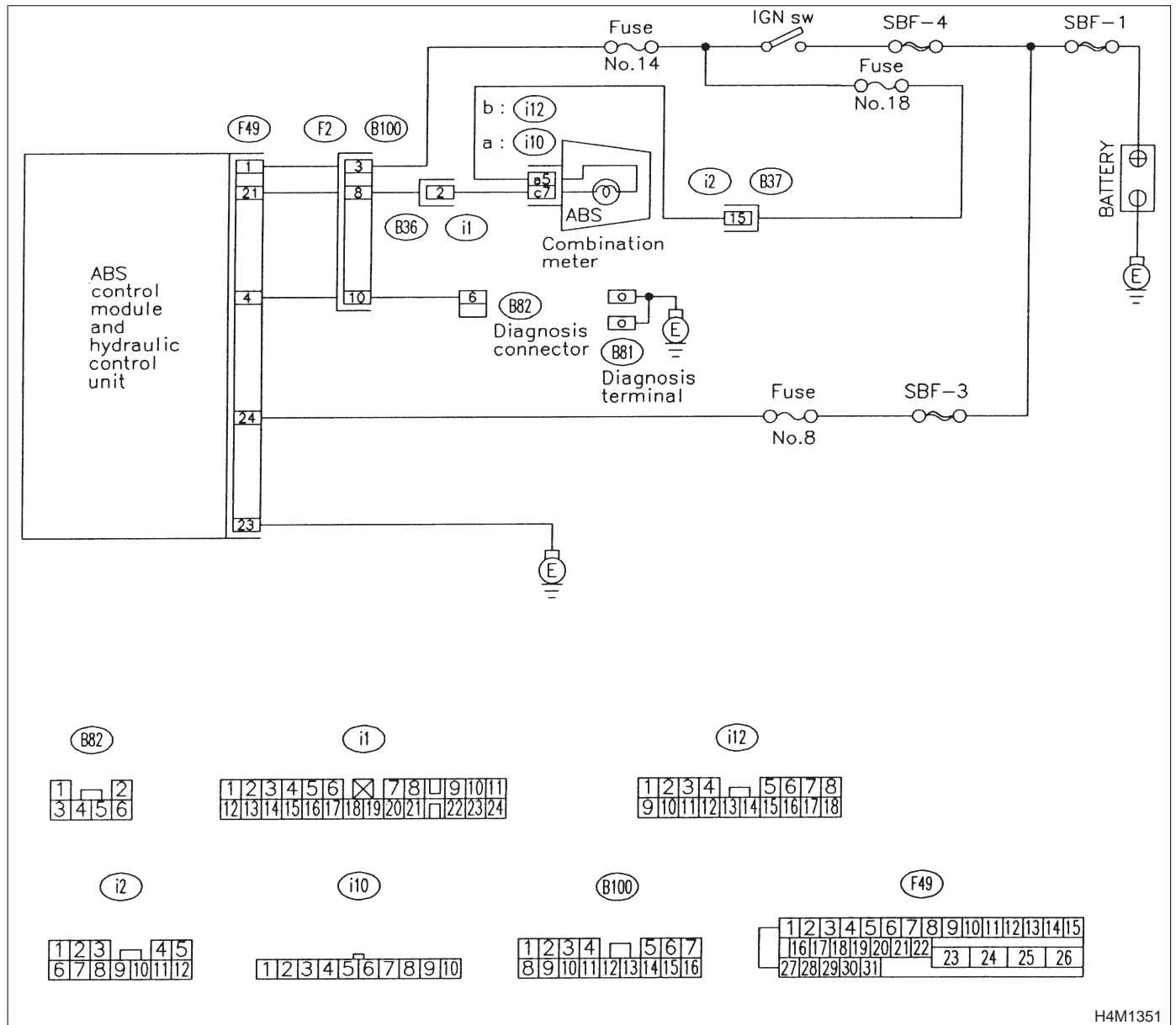

10D1 : CHECK WIRING HARNESS.

- 1) Turn ignition switch to OFF.
- 2) Disconnect connector (F2) from connector (B100).
- 3) Turn ignition switch to ON.

CHECK : Does the ABS warning light remain off?

YES : Go to step 10D2.

NO : Repair front wiring harness.

10D2 : CHECK PROJECTION AT ABSCM&H/U.

- 1) Turn ignition switch to OFF.
- 2) Disconnect connector from ABSCM&H/U.
- 3) Check for broken projection at the ABSCM&H/U terminal.

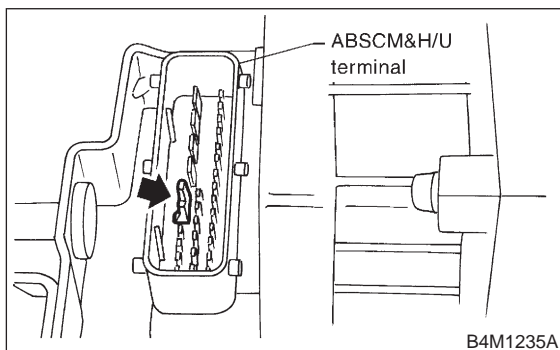

CHECK : Are the projection broken?

YES : Go to step 10D3.

NO : Replace ABSCM&H/U.

10D3 : CHECK ABSCM&H/U.

Measure resistance between ABSCM&H/U terminals.

Terminals

No. 21 — No. 23:

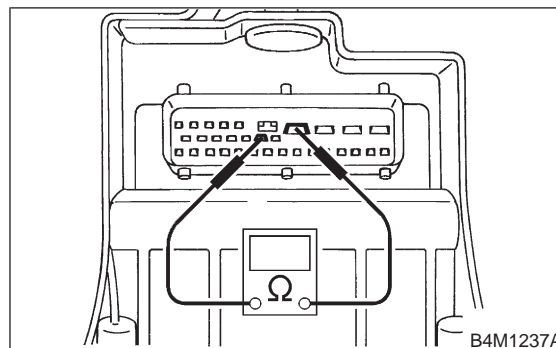

CHECK : Is the resistance more than 1 MΩ?

YES : Go to step 10D4.

NO : Replace valve relay.

10D4 : CHECK WIRING HARNESS.

Measure resistance between connector (F2) and chassis ground.

Connector & terminal

(F2) No. 8 — Chassis ground:

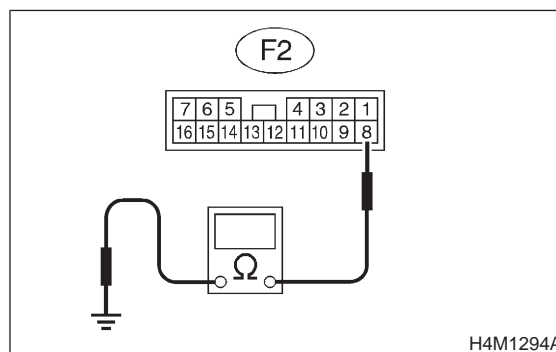

CHECK : Is the resistance less than 0.5 Ω?

YES : Go to step 10D5.

NO : Repair harness.

10D5 : CHECK WIRING HARNESS.

- 1) Connect connector to ABSCM&H/U.
- 2) Measure resistance between connector (F2) and chassis ground.

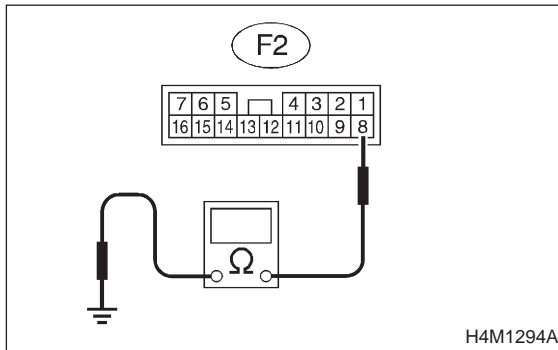
Connector & terminal**(F2) No. 8 — Chassis ground:**

- CHECK** : *Is the resistance more than 1 MΩ?*
- YES** : Go to step 10D6.
- NO** : Repair harness.

10D6 : CHECK POOR CONTACT IN ABSCM&H/U CONNECTOR.

- CHECK** : *Is there poor contact in ABSCM&H/U connector? <Ref. to FOREWORD [T3C1].>*
- YES** : Repair connector.
- NO** : Replace ABSCM&H/U.

MEMO:

E: TROUBLE CODE 21 OPEN OR SHORT CIRCUIT IN FRONT RIGHT ABS SENSOR CIRCUIT

F: TROUBLE CODE 23 OPEN OR SHORT CIRCUIT IN FRONT LEFT ABS SENSOR CIRCUIT

G: TROUBLE CODE 25 OPEN OR SHORT CIRCUIT IN REAR RIGHT ABS SENSOR CIRCUIT

H: TROUBLE CODE 27 OPEN OR SHORT CIRCUIT IN REAR LEFT ABS SENSOR CIRCUIT

— ABNORMAL ABS SENSOR (OPEN OR SHORT CIRCUIT IN ABS SENSOR CIRCUIT) —

DIAGNOSIS:

- Faulty ABS sensor (Broken wire, input voltage too high)
- Faulty harness connector

TROUBLE SYMPTOM:

- ABS does not operate.

WIRING DIAGRAM:

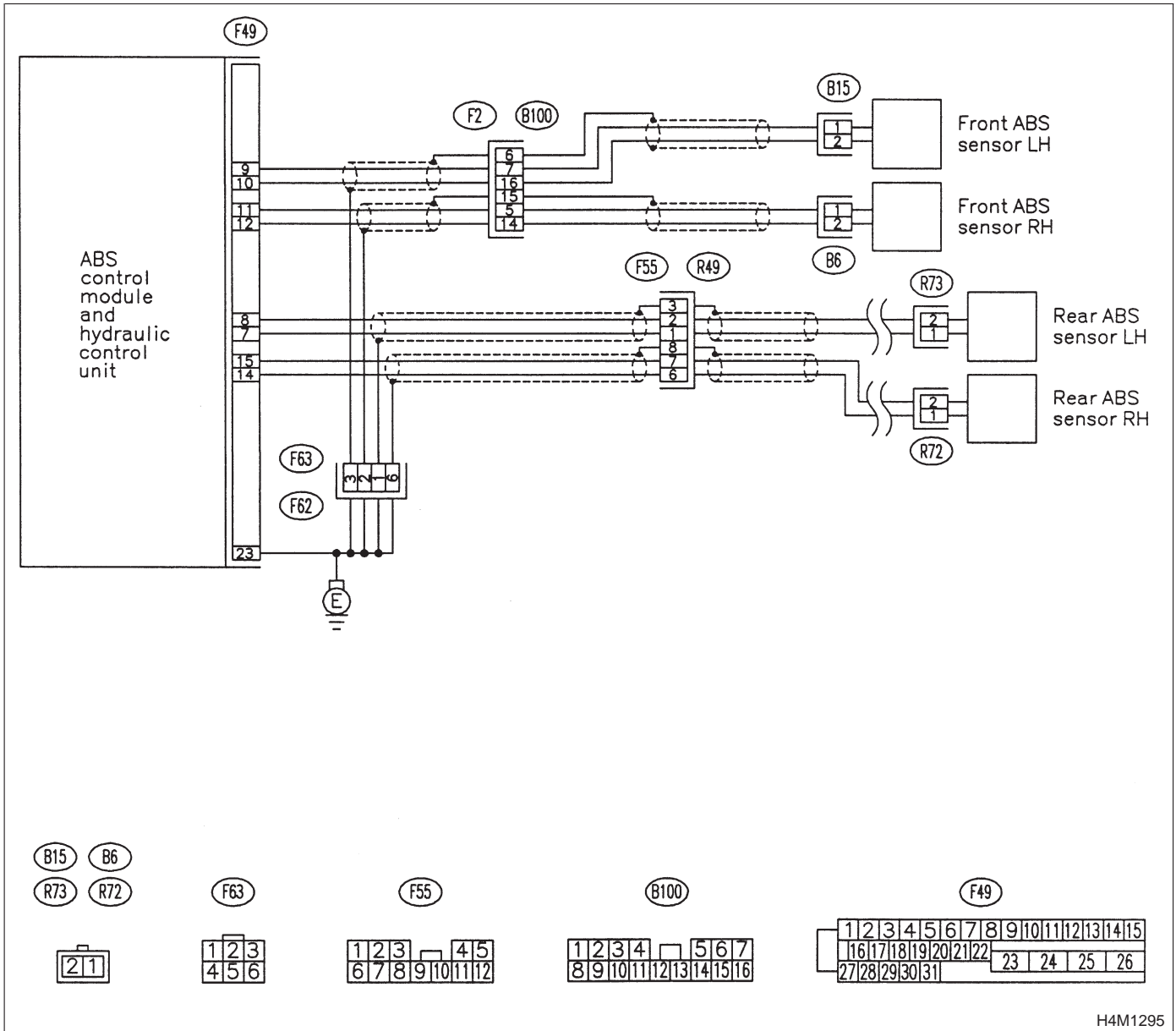

H4M1295

10H1 : CHECK OUTPUT OF ABS SENSOR USING SELECT MONITOR.

- 1) Select "Current data display & Save" on the select monitor.
- 2) Read the ABS sensor output corresponding to the faulty system in the select monitor data display mode.

CHECK : *Does the speed indicated on the display change in response to the speedometer reading during acceleration/deceleration when the steering wheel is in the straight-ahead position?*

YES : Go to step 10H2.

NO : Go to step 10H9.

10H2 : CHECK INSTALLATION OF ABS SENSOR.
Tightening torque:

32 ± 10 N-m (3.3 ± 1.0 kg-m, 24 ± 7 ft-lb)

CHECK : *Are the ABS sensor installation bolts tightened securely?*

YES : Go to step 10H3.

NO : Tighten ABS sensor installation bolts securely.

10H3 : CHECK INSTALLATION OF TONE WHEEL.
Tightening torque:

13 ± 3 N-m (1.3 ± 0.3 kg-m, 9 ± 2.2 ft-lb)

CHECK : *Are the tone wheel installation bolts tightened securely?*

YES : Go to step 10H4.

NO : Tighten tone wheel installation bolts securely.

10H4 : CHECK ABS SENSOR GAP.

Measure tone wheel-to-pole piece gap over entire perimeter of the wheel.

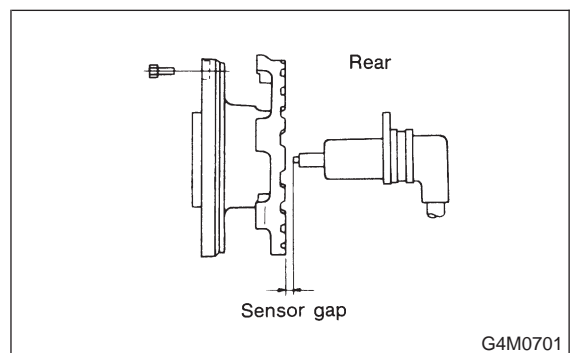
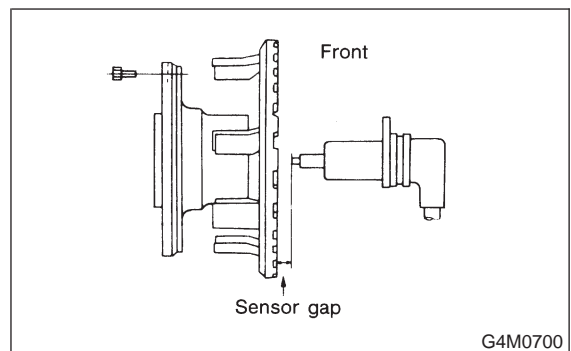

	Front wheel	Rear wheel
Specifications	0.9 — 1.4 mm (0.035 — 0.055 in)	0.7 — 1.2 mm (0.028 — 0.047 in)

CHECK : *Is the gap within the specifications?*

YES : Go to step 10H5.

NO : Adjust the gap.

NOTE:

Adjust the gap using spacers (Part No. 26755AA000). If spacers cannot correct the gap, replace worn sensor or worn tone wheel.

10H5 : CHECK HUB RUNOUT.

Measure hub runout.

CHECK : *Is the runout less than 0.05 mm (0.0020 in)?*

YES : Go to step 10H6.

NO : Repair hub.

10H6 : CHECK POOR CONTACT IN CONNECTORS.

Turn ignition switch to OFF.

CHECK : *Is there poor contact in connectors between ABSCM&H/U and ABS sensor? <Ref. to FOREWORD [T3C1].>*

YES : Repair connector.

NO : Go to step 10H7.

10H7 : CHECK ABSCM&H/U.

- 1) Connect all connectors.
- 2) Erase the memory.
- 3) Perform inspection mode.
- 4) Read out the trouble code.

CHECK : *Is the same trouble code as in the current diagnosis still being output?*

YES : Replace ABSCM&H/U.

NO : Go to step 10H8.

10H8 : CHECK ANY OTHER TROUBLE CODES APPEARANCE.

CHECK : *Are other trouble codes being output?*

YES : Proceed with the diagnosis corresponding to the trouble code.

NO : A temporary poor contact.

NOTE:

Check harness and connectors between ABSCM&H/U and ABS sensor.

10H9 : CHECK ABS SENSOR.

- 1) Turn ignition switch to OFF.
- 2) Disconnect connector from ABS sensor.
- 3) Measure resistance of ABS sensor connector terminals.

Terminal

Front RH No. 1 — No. 2:

Front LH No. 1 — No. 2:

Rear RH No. 1 — No. 2:

Rear LH No. 1 — No. 2:

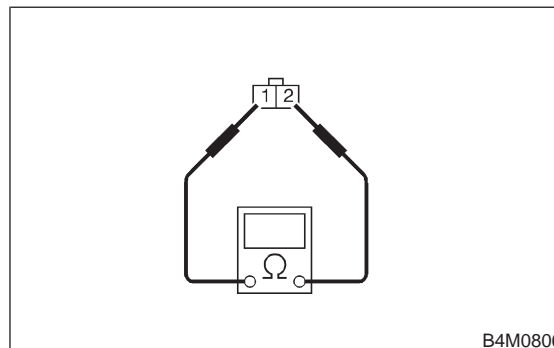

CHECK : *Is the resistance between 0.8 and 1.2 kΩ?*

YES : Go to step 10H10.

NO : Replace ABS sensor.

10H10 : CHECK BATTERY SHORT OF ABS SENSOR.

- 1) Disconnect connector from ABSCM&H/U.
- 2) Measure voltage between ABS sensor and chassis ground.

Terminal

- Front RH No. 1 (+) — Chassis ground (-):
- Front LH No. 1 (+) — Chassis ground (-):
- Rear RH No. 1 (+) — Chassis ground (-):
- Rear LH No. 1 (+) — Chassis ground (-):

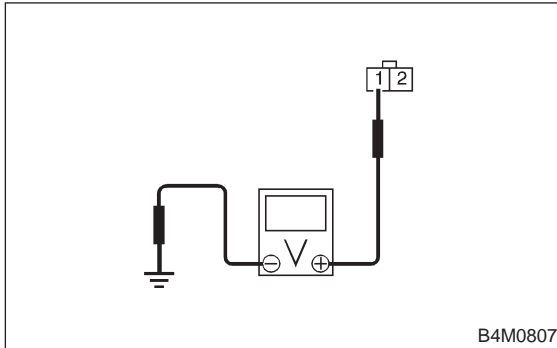

- CHECK** : Is the voltage less than 1 V?
- YES** : Go to step 10H11.
- NO** : Replace ABS sensor.

10H11 : CHECK BATTERY SHORT OF ABS SENSOR.

- 1) Turn ignition switch to ON.
- 2) Measure voltage between ABS sensor and chassis ground.

Terminal

- Front RH No. 1 (+) — Chassis ground (-):
- Front LH No. 1 (+) — Chassis ground (-):
- Rear RH No. 1 (+) — Chassis ground (-):
- Rear LH No. 1 (+) — Chassis ground (-):

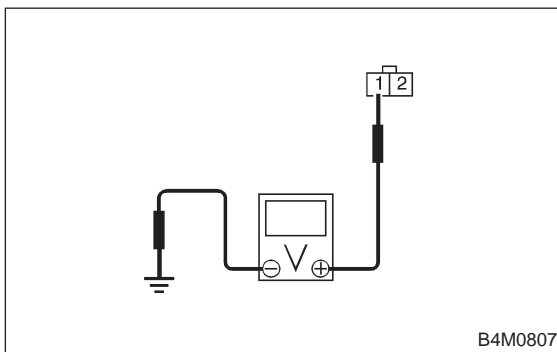

- CHECK** : Is the voltage less than 1 V?
- YES** : Go to step 10H12.
- NO** : Replace ABS sensor.

10H12 : CHECK HARNESS/CONNECTOR BETWEEN ABSCM&H/U AND ABS SENSOR.

- 1) Turn ignition switch to OFF.
- 2) Connect connector to ABS sensor.
- 3) Measure resistance between ABSCM&H/U connector terminals.

Connector & terminal

- Trouble code 21 / (F49) No. 11 — No. 12:
- Trouble code 23 / (F49) No. 9 — No. 10:
- Trouble code 25 / (F49) No. 14 — No. 15:
- Trouble code 27 / (F49) No. 7 — No. 8:

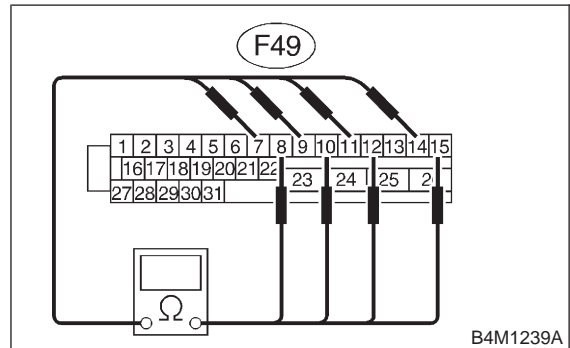

- CHECK** : Is the resistance between 0.8 and 1.2 kΩ?
- YES** : Go to step 10H13.
- NO** : Repair harness/connector between ABSCM&H/U and ABS sensor.

10H13 : CHECK BATTERY SHORT OF HARNESS.

Measure voltage between ABSCM&H/U connector and chassis ground.

Connector & terminal

- Trouble code 21 / (F49) No. 11 (+) — Chassis ground (-):**
- Trouble code 23 / (F49) No. 9 (+) — Chassis ground (-):**
- Trouble code 25 / (F49) No. 14 (+) — Chassis ground (-):**
- Trouble code 27 / (F49) No. 7 (+) — Chassis ground (-):**

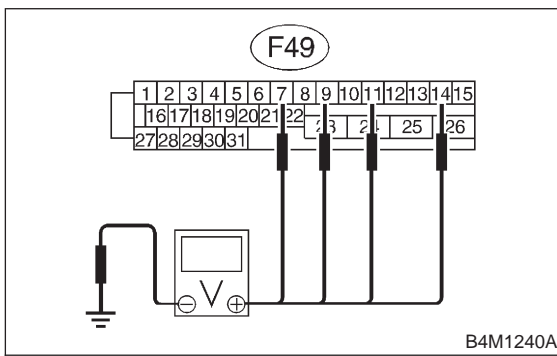

- CHECK** : *Is the voltage less than 1 V?*
- YES** : Go to step **10H14**.
- NO** : Repair harness between ABSCM&H/U and ABS sensor.

10H14 : CHECK BATTERY SHORT OF HARNESS.

- 1) Turn ignition switch to ON.
- 2) Measure voltage between ABSCM&H/U connector and chassis ground.

Connector & terminal

- Trouble code 21 / (F49) No. 11 (+) — Chassis ground (-):**
- Trouble code 23 / (F49) No. 9 (+) — Chassis ground (-):**
- Trouble code 25 / (F49) No. 14 (+) — Chassis ground (-):**
- Trouble code 27 / (F49) No. 7 (+) — Chassis ground (-):**

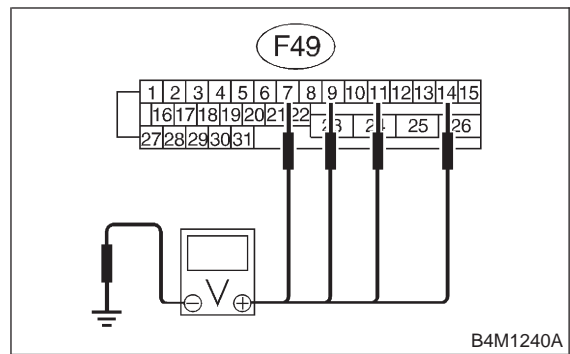

- CHECK** : *Is the voltage less than 1 V?*
- YES** : Go to step **10H15**.
- NO** : Repair harness between ABSCM&H/U and ABS sensor.

10H15 : CHECK INSTALLATION OF ABS SENSOR.

Tightening torque:

32±10 N·m (3.3±1.0 kg·m, 24±7 ft·lb)

- CHECK** : *Are the ABS sensor installation bolts tightened securely?*
- YES** : Go to step **10H16**.
- NO** : Tighten ABS sensor installation bolts securely.

10H16 : CHECK INSTALLATION OF TONE WHEEL.

Tightening torque:

13±3 N·m (1.3±0.3 kg·m, 9±2.2 ft·lb)

CHECK : Are the tone wheel installation bolts tightened securely?

YES : Go to step 10H17.

NO : Tighten tone wheel installation bolts securely.

10H17 : CHECK ABS SENSOR GAP.

Measure tone wheel-to-pole piece gap over entire perimeter of the wheel.

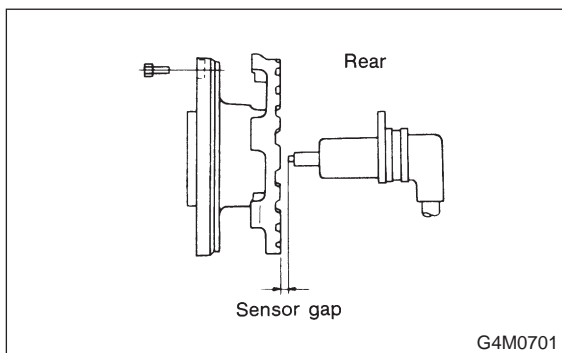
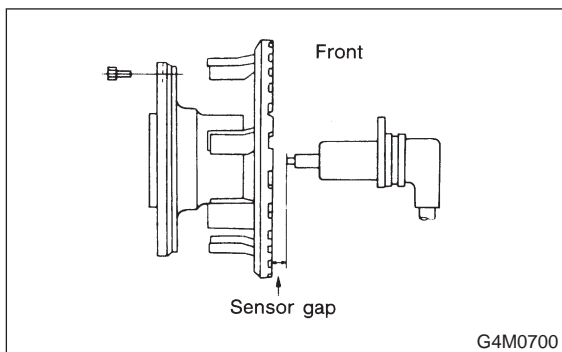

Specifications	Front wheel	Rear wheel
	0.9 — 1.4 mm (0.035 — 0.055 in)	0.7 — 1.2 mm (0.028 — 0.047 in)

CHECK : Is the gap within the specifications?

YES : Go to step 10H18.

NO : Adjust the gap.

NOTE:

Adjust the gap using spacers (Part No. 26755AA000). If spacers cannot correct the gap, replace worn sensor or worn tone wheel.

10H18 : CHECK HUB RUNOUT.

Measure hub runout.

CHECK : Is the runout less than 0.05 mm (0.0020 in)?

YES : Go to step 10H19.

NO : Repair hub.

10H19 : CHECK GROUND SHORT OF ABS SENSOR.

- 1) Turn ignition switch to ON.
- 2) Measure resistance between ABS sensor and chassis ground.

Terminal

Front RH No. 1 — Chassis ground:

Front LH No. 1 — Chassis ground:

Rear RH No. 1 — Chassis ground:

Rear LH No. 1 — Chassis ground:

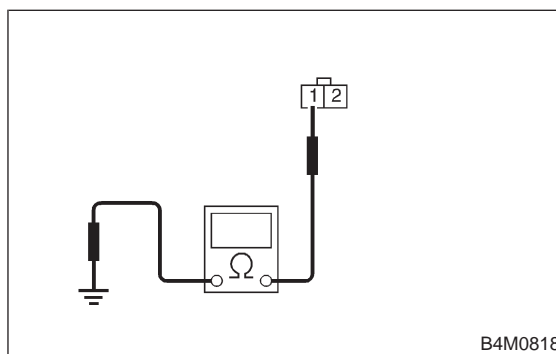

CHECK : Is the resistance more than 1 MΩ?

YES : Go to step 10H20.

NO : Replace ABS sensor and ABSCM&H/U.

10H20 : CHECK GROUND SHORT OF HARNESS.

- 1) Turn ignition switch to OFF.
- 2) Connect connector to ABS sensor.
- 3) Measure resistance between ABSCM&H/U connector terminal and chassis ground.

Connector & terminal

Trouble code 21 / (F49) No. 11 — Chassis ground:

Trouble code 23 / (F49) No. 9 — Chassis ground:

Trouble code 25 / (F49) No. 14 — Chassis ground:

Trouble code 27 / (F49) No. 7 — Chassis ground:

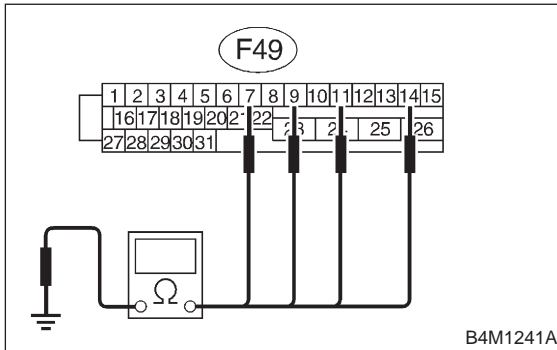

- CHECK** : *Is the resistance more than 1 MΩ?*
- YES** : Go to step **10H21**.
- NO** : Repair harness between ABSCM&H/U and ABS sensor.
And replace ABSCM&H/U.

10H21 : CHECK POOR CONTACT IN CONNECTORS.

- CHECK** : *Is there poor contact in connectors between ABSCM&H/U and ABS sensor? <Ref. to FOREWORD [T3C1].>*
- YES** : Repair connector.
- NO** : Go to step **10H22**.

10H22 : CHECK ABSCM&H/U.

- 1) Connect all connectors.
- 2) Erase the memory.
- 3) Perform inspection mode.
- 4) Read out the trouble code.

- CHECK** : *Is the same trouble code as in the current diagnosis still being output?*
- YES** : Replace ABSCM&H/U.
- NO** : Go to step **10H23**.

10H23 : CHECK ANY OTHER TROUBLE CODES APPEARANCE.

- CHECK** : *Are other trouble codes being output?*
- YES** : Proceed with the diagnosis corresponding to the trouble code.
- NO** : A temporary poor contact.

NOTE:

Check harness and connectors between ABSCM&H/U and ABS sensor.

I: TROUBLE CODE 22 FRONT RIGHT ABS SENSOR ABNORMAL SIGNAL

J: TROUBLE CODE 24 FRONT LEFT ABS SENSOR ABNORMAL SIGNAL

K: TROUBLE CODE 26 REAR RIGHT ABS SENSOR ABNORMAL SIGNAL

L: TROUBLE CODE 28 REAR LEFT ABS SENSOR ABNORMAL SIGNAL

— ABNORMAL ABS SENSOR (ABS SENSOR ABNORMAL SIGNAL) —

DIAGNOSIS:

- Faulty ABS sensor signal (noise, irregular signal, etc.)
- Faulty harness/connector

TROUBLE SYMPTOM:

- ABS does not operate.

WIRING DIAGRAM:

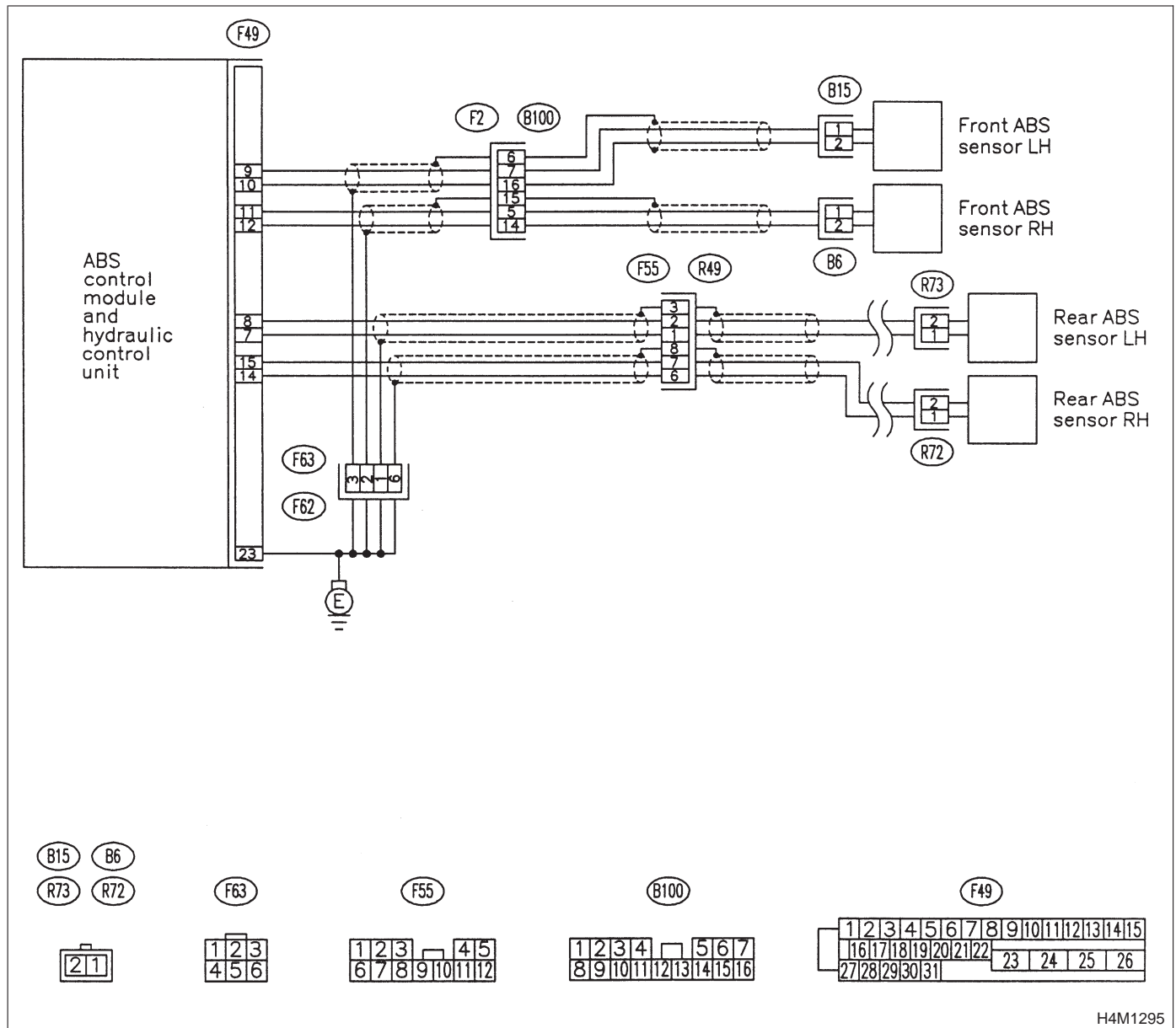

10L1 : CHECK OUTPUT OF ABS SENSOR USING SELECT MONITOR.

- 1) Select "Current data display & Save" on the select monitor.
- 2) Read the ABS sensor output corresponding to the faulty system in the select monitor data display mode.

CHECK : *Does the speed indicated on the display change in response to the speedometer reading during acceleration/deceleration when the steering wheel is in the straight-ahead position?*

YES : Go to step 10L2.

NO : Go to step 10L8.

10L2 : CHECK POOR CONTACT IN CONNECTORS.

Turn ignition switch to OFF.

CHECK : *Is there poor contact in connectors between ABSCM&H/U and ABS sensor?*

YES : Repair connector.

NO : Go to step 10L3.

10L3 : CHECK SOURCES OF SIGNAL NOISE.

CHECK : *Is the car telephone or the wireless transmitter properly installed?*

YES : Go to step 10L4.

NO : Properly install the car telephone or the wireless transmitter.

10L4 : CHECK SOURCES OF SIGNAL NOISE.

CHECK : *Are noise sources (such as an antenna) installed near the sensor harness?*

YES : Install the noise sources apart from the sensor harness.

NO : Go to step 10L5.

10L5 : CHECK SHIELD CIRCUIT.

- 1) Turn ignition switch to OFF.
- 2) Connect all connectors.
- 3) Measure resistance between shield connector and chassis ground.

Connector & terminal

Trouble code 22 / (B100) No. 15 — Chassis ground:

Trouble code 24 / (B100) No. 6 — Chassis ground:

Trouble code 26 / (F55) No. 8 — Chassis ground:

Trouble code 28 / (F55) No. 3 — Chassis ground:

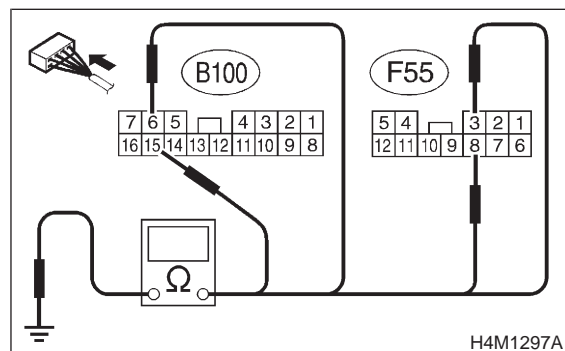

CHECK : *Is the resistance less than 0.5 Ω?*

YES : Go to step 10L6.

NO : Repair shield harness.

10L6 : CHECK ABSCM&H/U.

- 1) Connect all connectors.
- 2) Erase the memory.
- 3) Perform inspection mode.
- 4) Read out the trouble code.

CHECK : *Is the same trouble code as in the current diagnosis still being output?*

YES : Replace ABSCM&H/U.

NO : Go to step 10L7.

10L7 : CHECK ANY OTHER TROUBLE CODES APPEARANCE.

CHECK : *Are other trouble codes being output?*

YES : Proceed with the diagnosis corresponding to the trouble code.

NO : A temporary noise interference.

10L8 : CHECK INSTALLATION OF ABS SENSOR.

Tightening torque:

32±10 N-m (3.3±1.0 kg-m, 24±7 ft-lb)

- CHECK** : Are the ABS sensor installation bolts tightened securely?
- YES** : Go to step 10L9.
- NO** : Tighten ABS sensor installation bolts securely.

10L9 : CHECK INSTALLATION OF TONE WHEEL.

Tightening torque:

13±3 N-m (1.3±0.3 kg-m, 9±2.2 ft-lb)

- CHECK** : Are the tone wheel installation bolts tightened securely?
- YES** : Go to step 10L10.
- NO** : Tighten tone wheel installation bolts securely.

10L10 : CHECK ABS SENSOR GAP.

Measure tone wheel to pole piece gap over entire perimeter of the wheel.

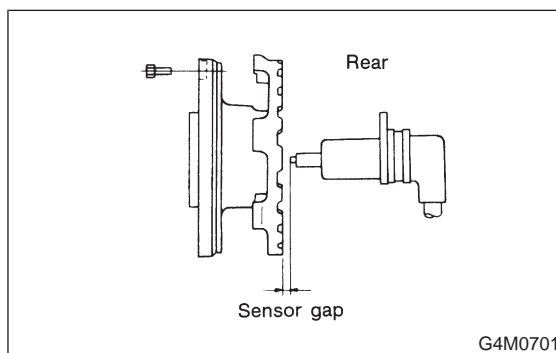
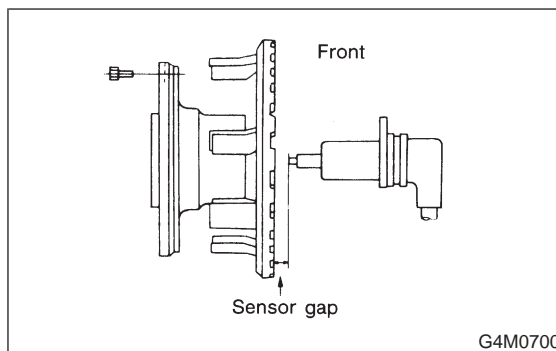

	Front wheel	Rear wheel
Specifications	0.9 — 1.4 mm (0.035 — 0.055 in)	0.7 — 1.2 mm (0.028 — 0.047 in)

- CHECK** : Is the gap within the specifications?
- YES** : Go to step 10L11.
- NO** : Adjust the gap.

NOTE:

Adjust the gap using spacer (Part No. 26755AA000). If spacers cannot correct the gap, replace worn sensor or worn tone wheel.

10L11 : CHECK OSCILLOSCOPE.

- CHECK** : Is an oscilloscope available?
- YES** : Go to step 10L12.
- NO** : Go to step 10L13.

10L12 : CHECK ABS SENSOR SIGNAL.

- 1) Raise all four wheels of ground.
- 2) Turn ignition switch OFF.
- 3) Connect the oscilloscope to the connector.
- 4) Turn ignition switch ON.
- 5) Rotate wheels and measure voltage at specified frequency.

NOTE:

When this inspection is completed, the ABSCM&H/U sometimes stores the trouble code 29.

Connector & terminal

Trouble code 22 / (B100) No. 5 (+) — No. 14 (-):

Trouble code 24 / (B100) No. 7 (+) — No. 16 (-):

Trouble code 26 / (F55) No. 6 (+) — No. 7 (-):

Trouble code 28 / (F55) No. 1 (+) — No. 2 (-):

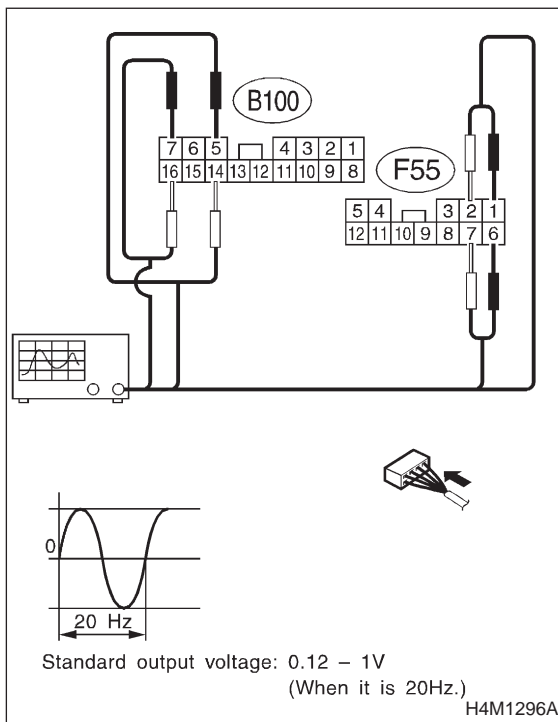

CHECK : *Is oscilloscope pattern smooth, as shown in figure?*

YES : Go to step 10L16.

NO : Go to step 10L13.

10L13 : CHECK CONTAMINATION OF ABS SENSOR OR TONE WHEEL.

Remove disc rotor or drum from hub in accordance with trouble code.

CHECK : *Is the ABS sensor pole piece or the tone wheel contaminated by dirt or other foreign matter?*

YES : Thoroughly remove dirt or other foreign matter.

NO : Go to step 10L14.

10L14 : CHECK DAMAGE OF ABS SENSOR OR TONE WHEEL.

CHECK : *Are there broken or damaged in the ABS sensor pole piece or the tone wheel?*

YES : Replace ABS sensor or tone wheel.

NO : Go to step 10L15.

10L15 : CHECK HUB RUNOUT.

Measure hub runout.

CHECK : *Is the runout less than 0.05 mm (0.0020 in)?*

YES : Go to step 10L16.

NO : Repair hub.

10L16 : CHECK RESISTANCE OF ABS SENSOR.

- 1) Turn ignition switch OFF.
- 2) Disconnect connector from ABS sensor.
- 3) Measure resistance between ABS sensor connector terminals.

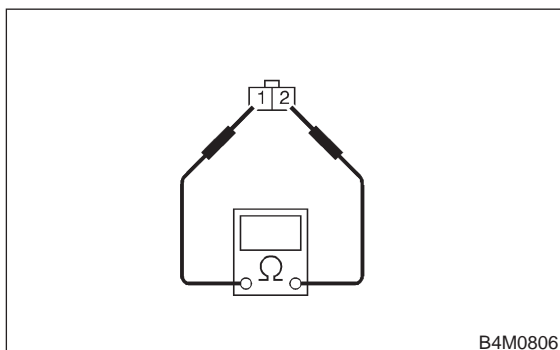
Terminal**Front RH No. 1 — No. 2:****Front LH No. 1 — No. 2:****Rear RH No. 1 — No. 2:****Rear LH No. 1 — No. 2:**

CHECK : **Is the resistance between 0.8 and 1.2 kΩ?**

YES : Go to step **10L17**.

NO : Replace ABS sensor.

10L17 : CHECK GROUND SHORT OF ABS SENSOR.

Measure resistance between ABS sensor and chassis ground.

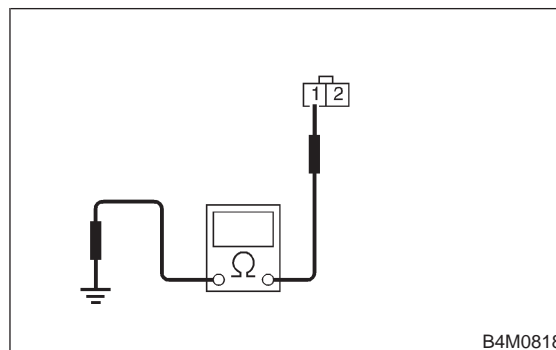
Terminal**Front RH No. 1 — Chassis ground:****Front LH No. 1 — Chassis ground:****Rear RH No. 1 — Chassis ground:****Rear LH No. 1 — Chassis ground:**

CHECK : **Is the resistance more than 1 MΩ?**

YES : Go to step **10L18**.

NO : Replace ABS sensor.

10L18 : CHECK HARNESS/CONNECTOR BETWEEN ABSCM&H/U AND ABS SENSOR.

- 1) Connect connector to ABS sensor.
- 2) Disconnect connector from ABSCM&H/U.
- 3) Measure resistance at ABSCM&H/U connector terminals.

Connector & terminal

- Trouble code 22 / (F49) No. 11 — No. 12:**
- Trouble code 24 / (F49) No. 9 — No. 10:**
- Trouble code 26 / (F49) No. 14 — No. 15:**
- Trouble code 28 / (F49) No. 7 — No. 8:**

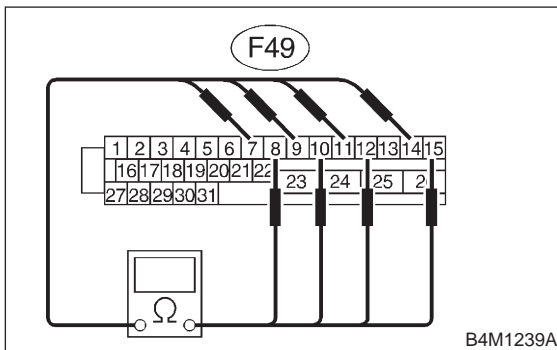

- CHECK** : Is the resistance between 0.8 and 1.2 kΩ?
- YES** : Go to step 10L19.
- NO** : Repair harness/connector between ABSCM&H/U and ABS sensor.

10L19 : CHECK GROUND SHORT OF HARNESS.

Measure resistance between ABSCM&H/U connector and chassis ground.

Connector & terminal

- Trouble code 22 / (F49) No. 11 — Chassis ground:**
- Trouble code 24 / (F49) No. 9 — Chassis ground:**
- Trouble code 26 / (F49) No. 14 — Chassis ground:**
- Trouble code 28 / (F49) No. 7 — Chassis ground:**

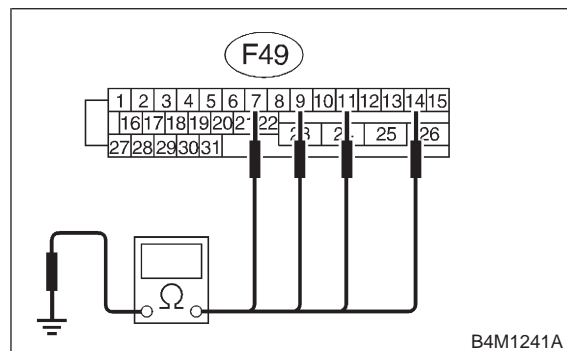

- CHECK** : Is the resistance more than 1 MΩ?
- YES** : Go to step 10L20.
- NO** : Repair harness/connector between ABSCM&H/U and ABS sensor.

10L20 : CHECK GROUND CIRCUIT OF ABSCM&H/U.

Measure resistance between ABSCM&H/U and chassis ground.

Connector & terminal

(F49) No. 23 — GND:

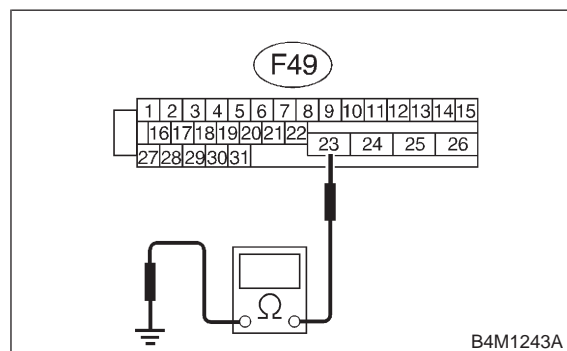

- CHECK** : Is the resistance less than 0.5 Ω?
- YES** : Go to step 10L21.
- NO** : Repair ABSCM&H/U ground harness.

10L21 : CHECK POOR CONTACT IN CONNECTORS.

CHECK : *Is there poor contact in connectors between ABSCM&H/U and ABS sensor? <Ref. to FOREWORD [T3C1].>*

YES : Repair connector.

NO : Go to step 10L22.

10L22 : CHECK SOURCES OF SIGNAL NOISE.

CHECK : *Is the car telephone or the wireless transmitter properly installed?*

YES : Go to step 10L23.

NO : Properly install the car telephone or the wireless transmitter.

10L23 : CHECK SOURCES OF SIGNAL NOISE.

CHECK : *Are noise sources (such as an antenna) installed near the sensor harness?*

YES : Install the noise sources apart from the sensor harness.

NO : Go to step 10L24.

10L24 : CHECK SHIELD CIRCUIT.

- 1) Connect all connectors.
- 2) Measure resistance between shield connector and chassis ground.

Connector & terminal

Trouble code 22 / (B100) No. 15 — Chassis ground:

Trouble code 24 / (B100) No. 6 — Chassis ground:

Trouble code 26 / (F55) No. 8 — Chassis ground:

Trouble code 28 / (F55) No. 3 — Chassis ground:

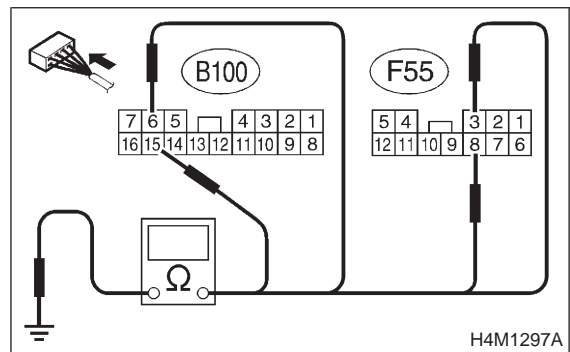

CHECK : *Is the resistance less than 0.5 Ω ?*

YES : Go to step 10L25.

NO : Repair shield harness.

10L25 : CHECK ABSCM&H/U.

- 1) Connect all connectors.
- 2) Erase the memory.
- 3) Perform inspection mode.
- 4) Read out the trouble code.

CHECK : *Is the same trouble code as in the current diagnosis still being output?*

YES : Replace ABSCM&H/U.

NO : Go to step 10L26.

10L26 : CHECK ANY OTHER TROUBLE CODES APPEARANCE.

CHECK : *Are other trouble codes being output?*

YES : Proceed with the diagnosis corresponding to the trouble code.

NO : A temporary noise interference.

MEMO:

M: TROUBLE CODE 29 ABNORMAL ABS SENSOR SIGNAL ON ANY ONE OF FOUR SENSOR

— ABNORMAL ABS SENSOR SIGNAL ON ANY ONE OF FOUR —

DIAGNOSIS:

- Faulty ABS sensor signal (noise, irregular signal, etc.)
- Faulty tone wheel
- Wheels turning freely for a long time

TROUBLE SYMPTOM:

- ABS does not operate.

WIRING DIAGRAM:

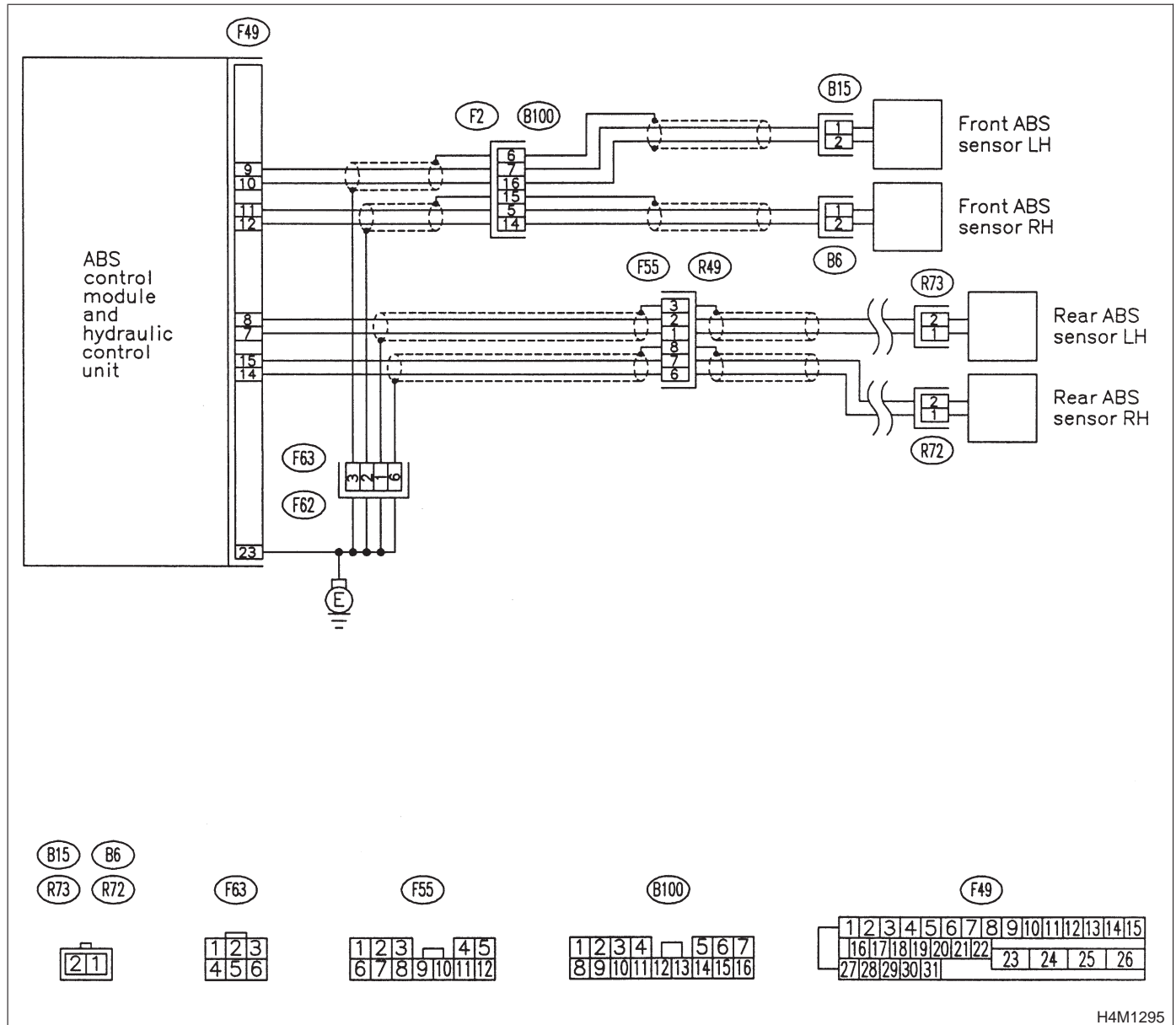

H4M1295

10M1 : CHECK IF THE WHEELS HAVE TURNED FREELY FOR A LONG TIME.

- CHECK** : Check if the wheels have been turned freely for more than one minute, such as when the vehicle is jacked-up, under full-lock cornering or when tire is not in contact with road surface.
- YES** : The ABS is normal. Erase the trouble code.

NOTE:

When the wheels turn freely for a long time, such as when the vehicle is towed or jacked-up, or when steering wheel is continuously turned all the way, this trouble code may sometimes occur.

- NO** : Go to step 10M2.

10M2 : CHECK TIRE SPECIFICATIONS.

Turn ignition switch to OFF.

- CHECK** : Are the tire specifications correct?
- YES** : Go to step 10M3.
- NO** : Replace tire.

10M3 : CHECK WEAR OF TIRE.

- CHECK** : Is the tire worn excessively?
- YES** : Replace tire.
- NO** : Go to step 10M4.

10M4 : CHECK TIRE PRESSURE.

- CHECK** : Is the tire pressure correct?
- YES** : Go to step 10M5.
- NO** : Adjust tire pressure.

10M5 : CHECK INSTALLATION OF ABS SENSOR.

Tightening torque:

32±10 N-m (3.3±1.0 kg-m, 24±7 ft-lb)

- CHECK** : Are the ABS sensor installation bolts tightened securely?
- YES** : Go to step 10M6.
- NO** : Tighten ABS sensor installation bolts securely.

10M6 : CHECK INSTALLATION OF TONE WHEEL.

Tightening torque:

13±3 N-m (1.3±0.3 kg-m, 9±2.2 ft-lb)

- CHECK** : Are the tone wheel installation bolts tightened securely?
- YES** : Go to step 10M7.
- NO** : Tighten tone wheel installation bolts securely.

10M7 : CHECK ABS SENSOR GAP.

Measure tone wheel to pole piece gap over entire perimeter of the wheel.

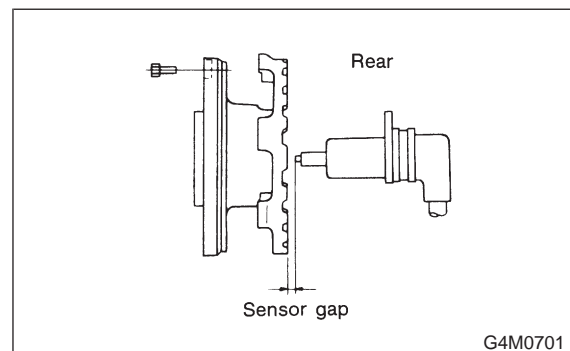
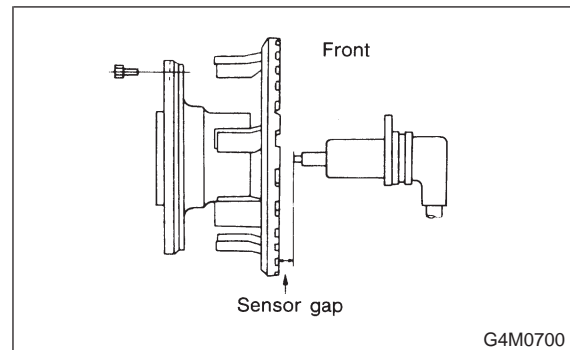

	Front wheel	Rear wheel
Specifications	0.9 — 1.4 mm (0.035 — 0.055 in)	0.7 — 1.2 mm (0.028 — 0.047 in)

- CHECK** : Is the gap within the specifications?
- YES** : Go to step 10M8.
- NO** : Adjust the gap.

NOTE:

Adjust the gap using spacer (Part No. 26755AA000). If spacers cannot correct the gap, replace worn sensor or worn tone wheel.

10M8 : CHECK OSCILLOSCOPE.

- CHECK** : *Is an oscilloscope available?*
- YES** : Go to step **10M9**.
- NO** : Go to step **10M10**.

10M9 : CHECK ABS SENSOR SIGNAL.

- 1) Raise all four wheels of ground.
- 2) Turn ignition switch OFF.
- 3) Connect the oscilloscope to the connector.
- 4) Turn ignition switch ON.
- 5) Rotate wheels and measure voltage at specified frequency.

NOTE:

When this inspection is completed, the ABSCM&H/U sometimes stores the trouble code 29.

Connector & terminal

- (B100) No. 5 (+) — No. 14 (-) (Front RH):**
- (B100) No. 7 (+) — No. 16 (-) (Front LH):**
- (F55) No. 6 (+) — No. 7 (-) (Rear RH):**
- (F55) No. 1 (+) — No. 2 (-) (Rear LH):**

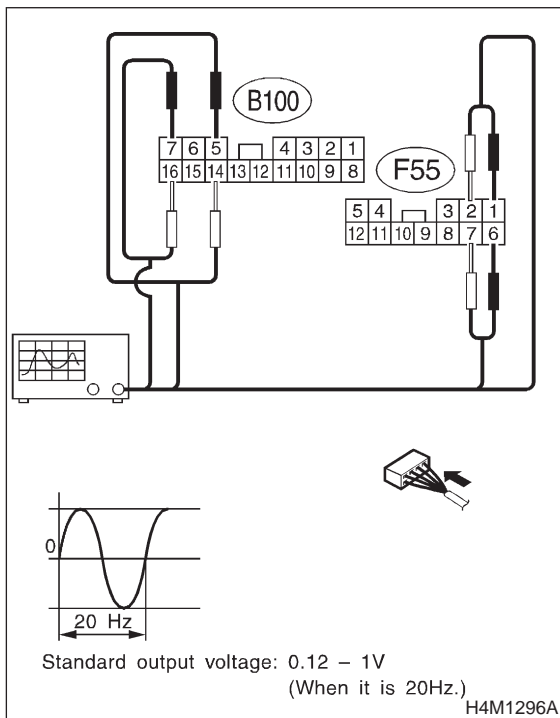

- CHECK** : *Is oscilloscope pattern smooth, as shown in figure?*
- YES** : Go to step **10M13**.
- NO** : Go to step **10M10**.

10M10 : CHECK CONTAMINATION OF ABS SENSOR OR TONE WHEEL.

Remove disc rotor from hub.

- CHECK** : *Is the ABS sensor pole piece or the tone wheel contaminated by dirt or other foreign matter?*
- YES** : Thoroughly remove dirt or other foreign matter.
- NO** : Go to step **10M11**.

10M11 : CHECK DAMAGE OF ABS SENSOR OR TONE WHEEL.

- CHECK** : *Are there broken or damaged teeth in the ABS sensor pole piece or the tone wheel?*
- YES** : Replace ABS sensor or tone wheel.
- NO** : Go to step **10M12**.

10M12 : CHECK HUB RUNOUT.

Measure hub runout.

- CHECK** : *Is the runout less than 0.05 mm (0.0020 in)?*
- YES** : Go to step **10M13**.
- NO** : Repair hub.

10M13 : CHECK ABSCM&H/U.

- 1) Turn ignition switch to OFF.
- 2) Connect all connectors.
- 3) Erase the memory.
- 4) Perform inspection mode.
- 5) Read out the trouble code.

- CHECK** : *Is the same trouble code as in the current diagnosis still being output?*
- YES** : Replace ABSCM&H/U.
- NO** : Go to step **10M14**.

10M14 : CHECK ANY OTHER TROUBLE CODES APPEARANCE.

- CHECK** : *Are other trouble codes being output?*
- YES** : Proceed with the diagnosis corresponding to the trouble code.
- NO** : A temporary poor contact.

MEMO:

N: TROUBLE CODE 31 FRONT RIGHT INLET VALVE MALFUNCTION

O: TROUBLE CODE 33 FRONT LEFT INLET VALVE MALFUNCTION

P: TROUBLE CODE 35 REAR RIGHT INLET VALVE MALFUNCTION

Q: TROUBLE CODE 37 REAR LEFT INLET VALVE MALFUNCTION

— INLET SOLENOID VALVE MALFUNCTION —

DIAGNOSIS:

- Faulty harness/connector
- Faulty inlet solenoid valve

TROUBLE SYMPTOM:

- ABS does not operate.

WIRING DIAGRAM:

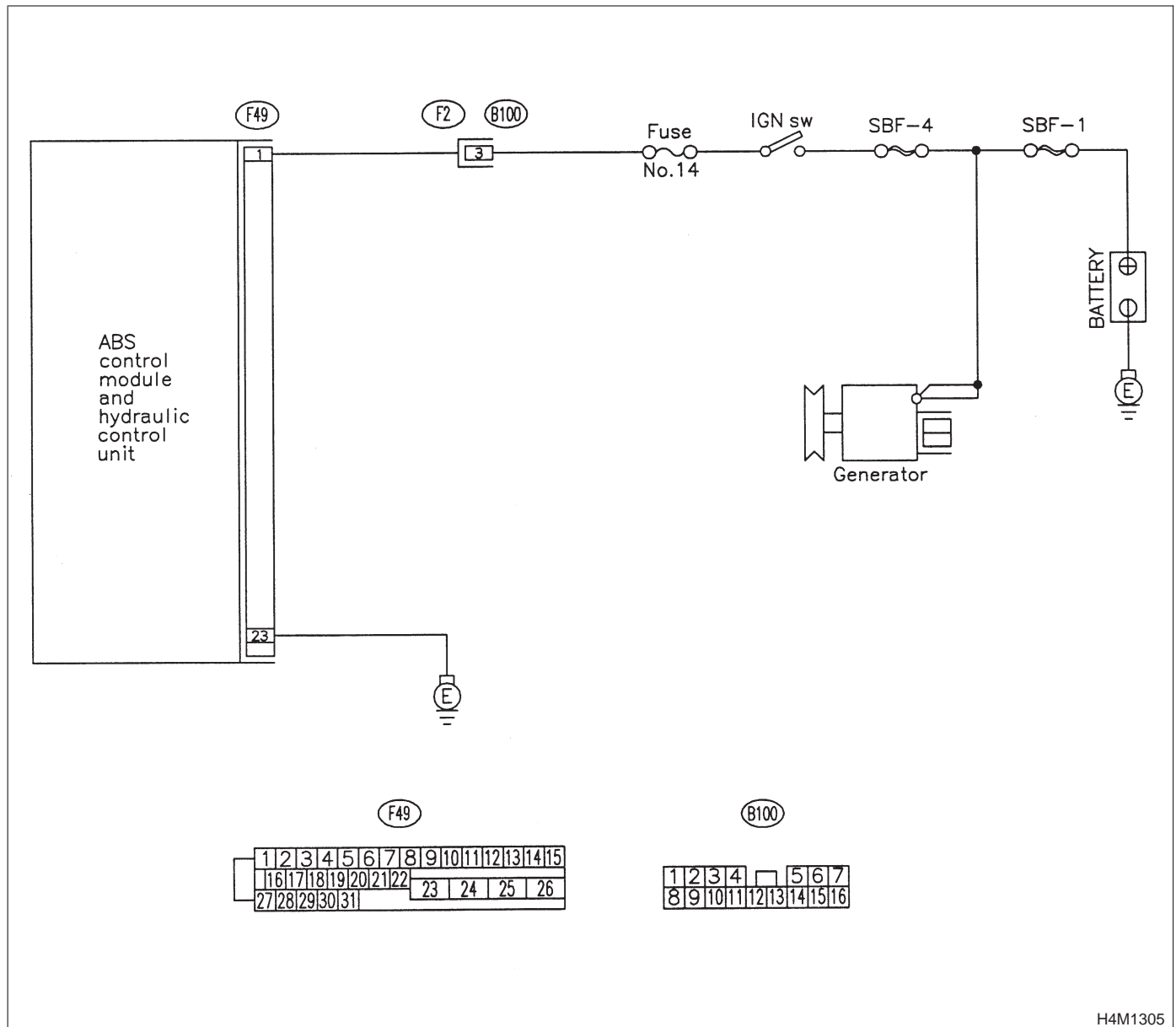

10Q1 : CHECK INPUT VOLTAGE OF ABSCM&H/U.

- 1) Turn ignition switch to OFF.
- 2) Disconnect connector from ABSCM&H/U.
- 3) Run the engine at idle.
- 4) Measure voltage between ABSCM&H/U connector and chassis ground.

Connector & terminal

(F49) No. 1 (+) — Chassis ground (-):

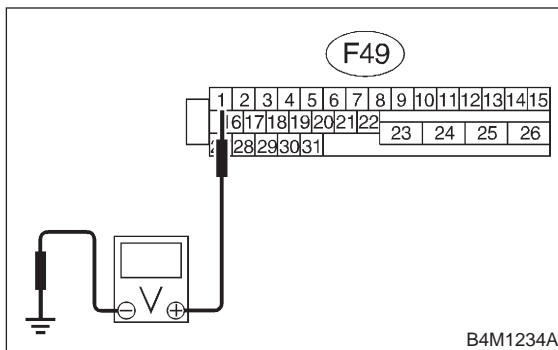

CHECK : **Is the voltage between 10 V and 15 V?**

YES : Go to step 10Q2.

NO : Repair harness connector between battery, ignition switch and ABSCM&H/U.

10Q2 : CHECK GROUND CIRCUIT OF ABSCM&H/U.

- 1) Turn ignition switch to OFF.
- 2) Measure resistance between ABSCM&H/U connector and chassis ground.

Connector & terminal

(F49) No. 23 — Chassis ground:

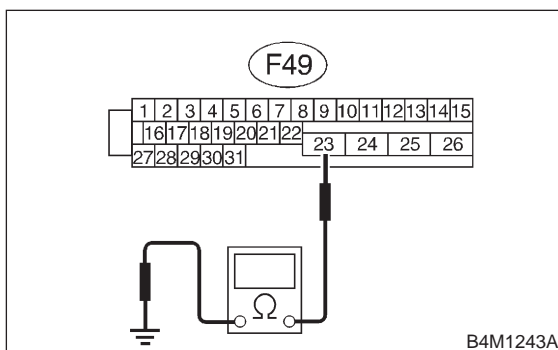

CHECK : **Is the resistance less than 0.5 Ω?**

YES : Go to step 10Q3.

NO : Repair ABSCM&H/U ground harness.

10Q3 : CHECK POOR CONTACT IN CONNECTORS.

CHECK : **Is there poor contact in connectors between generator, battery and ABSCM&H/U? <Ref. to FOREWORD [T3C1].>**

YES : Repair connector.

NO : Go to step 10Q4.

10Q4 : CHECK ABSCM&H/U.

- 1) Connect all connectors.
- 2) Erase the memory.
- 3) Perform inspection mode.
- 4) Read out the trouble code.

CHECK : **Is the same trouble code as in the current diagnosis still being output?**

YES : Replace ABSCM&H/U.

NO : Go to step 10Q5.

10Q5 : CHECK ANY OTHER TROUBLE CODES APPEARANCE.

CHECK : **Are other trouble codes being output?**

YES : Proceed with the diagnosis corresponding to the trouble code.

NO : A temporary poor contact.

R: TROUBLE CODE 32 FRONT RIGHT OUTLET VALVE MALFUNCTION

S: TROUBLE CODE 34 FRONT LEFT OUTLET VALVE MALFUNCTION

T: TROUBLE CODE 36 REAR RIGHT OUTLET VALVE MALFUNCTION

U: TROUBLE CODE 38 REAR LEFT OUTLET VALVE MALFUNCTION

— OUTLET SOLENOID VALVE MALFUNCTION —

DIAGNOSIS:

- Faulty harness/connector
- Faulty outlet solenoid valve

TROUBLE SYMPTOM:

- ABS does not operate.

WIRING DIAGRAM:

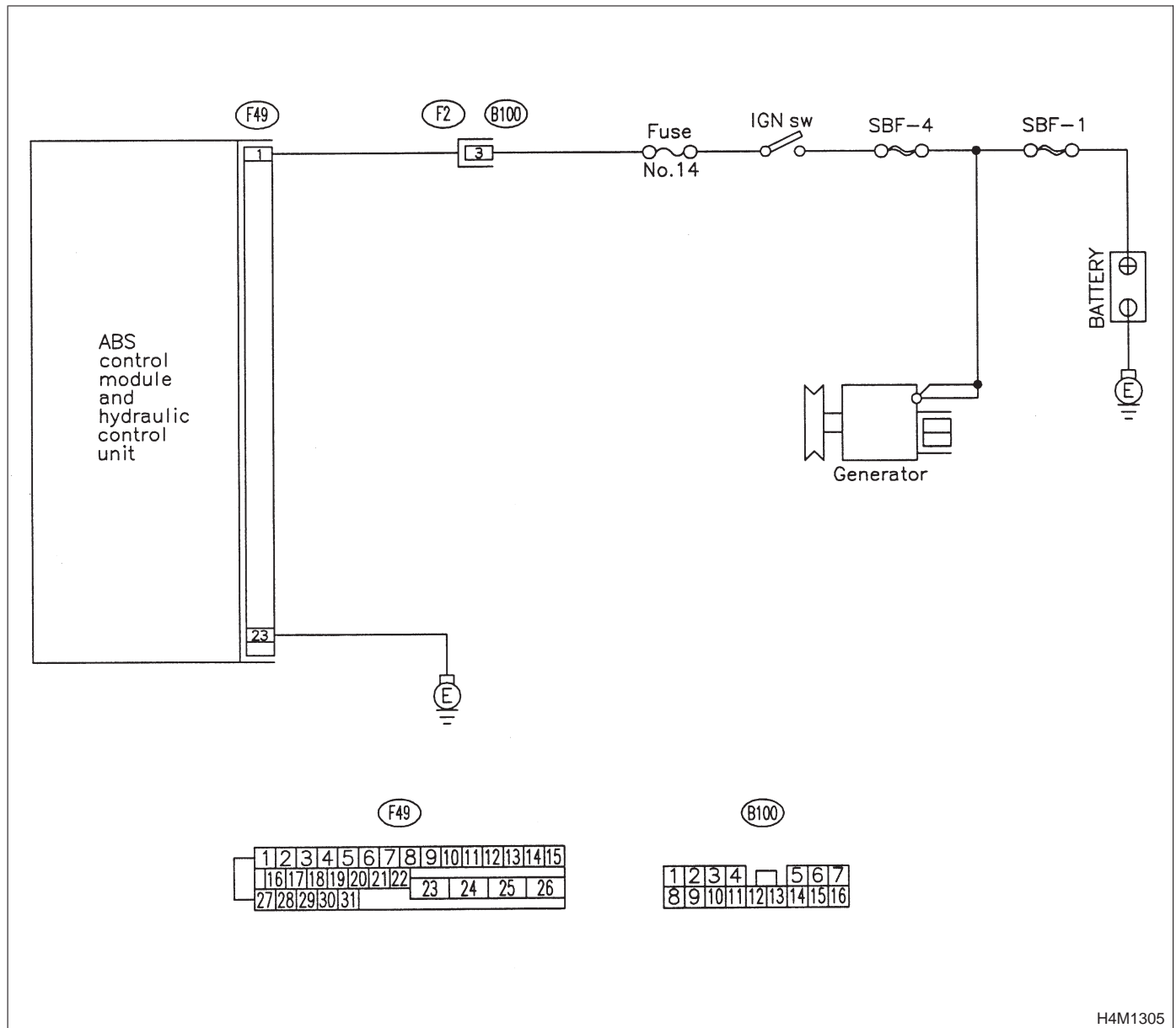

H4M1305

10U1 : CHECK INPUT VOLTAGE OF ABSCM&H/U.

- 1) Turn ignition switch to OFF.
- 2) Disconnect connector from ABSCM&H/U.
- 3) Run the engine at idle.
- 4) Measure voltage between ABSCM&H/U connector and chassis ground.

Connector & terminal

(F49) No. 1 (+) — Chassis ground (-):

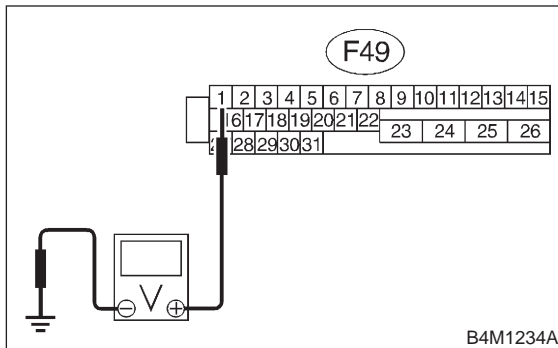

- CHECK** : **Is the voltage between 10 V and 15 V?**
- YES** : Go to step 10U2.
- NO** : Repair harness connector between battery, ignition switch and ABSCM&H/U.

10U2 : CHECK GROUND CIRCUIT OF ABSCM&H/U.

- 1) Turn ignition switch to OFF.
- 2) Measure resistance between ABSCM&H/U connector and chassis ground.

Connector & terminal

(F49) No. 23 — Chassis ground:

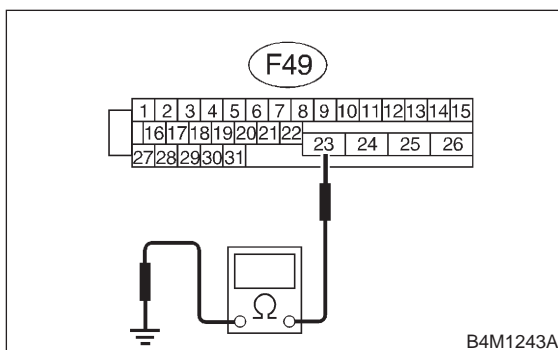

- CHECK** : **Is the resistance less than 0.5 Ω?**
- YES** : Go to step 10U3.
- NO** : Repair ABSCM&H/U ground harness.

10U3 : CHECK POOR CONTACT IN CONNECTORS.

- CHECK** : **Is there poor contact in connectors between generator, battery and ABSCM&H/U? <Ref. to FOREWORD [T3C1].>**
- YES** : Repair connector.
- NO** : Go to step 10U4.

10U4 : CHECK ABSCM&H/U.

- 1) Connect all connectors.
 - 2) Erase the memory.
 - 3) Perform inspection mode.
 - 4) Read out the trouble code.
- CHECK** : **Is the same trouble code as in the current diagnosis still being output?**
- YES** : Replace ABSCM&H/U.
- NO** : Go to step 10U5.

10U5 : CHECK ANY OTHER TROUBLE CODES APPEARANCE.

- CHECK** : **Are other trouble codes being output?**
- YES** : Proceed with the diagnosis corresponding to the trouble code.
- NO** : A temporary poor contact.

**V: TROUBLE CODE 41 ABS CONTROL MODULE MALFUNCTION
 — ABS CONTROL MODULE AND HYDRAULIC CONTROL UNIT
 MALFUNCTION—**

DIAGNOSIS:

- Faulty ABSCM&H/U

TROUBLE SYMPTOM:

- ABS does not operate.

WIRING DIAGRAM:

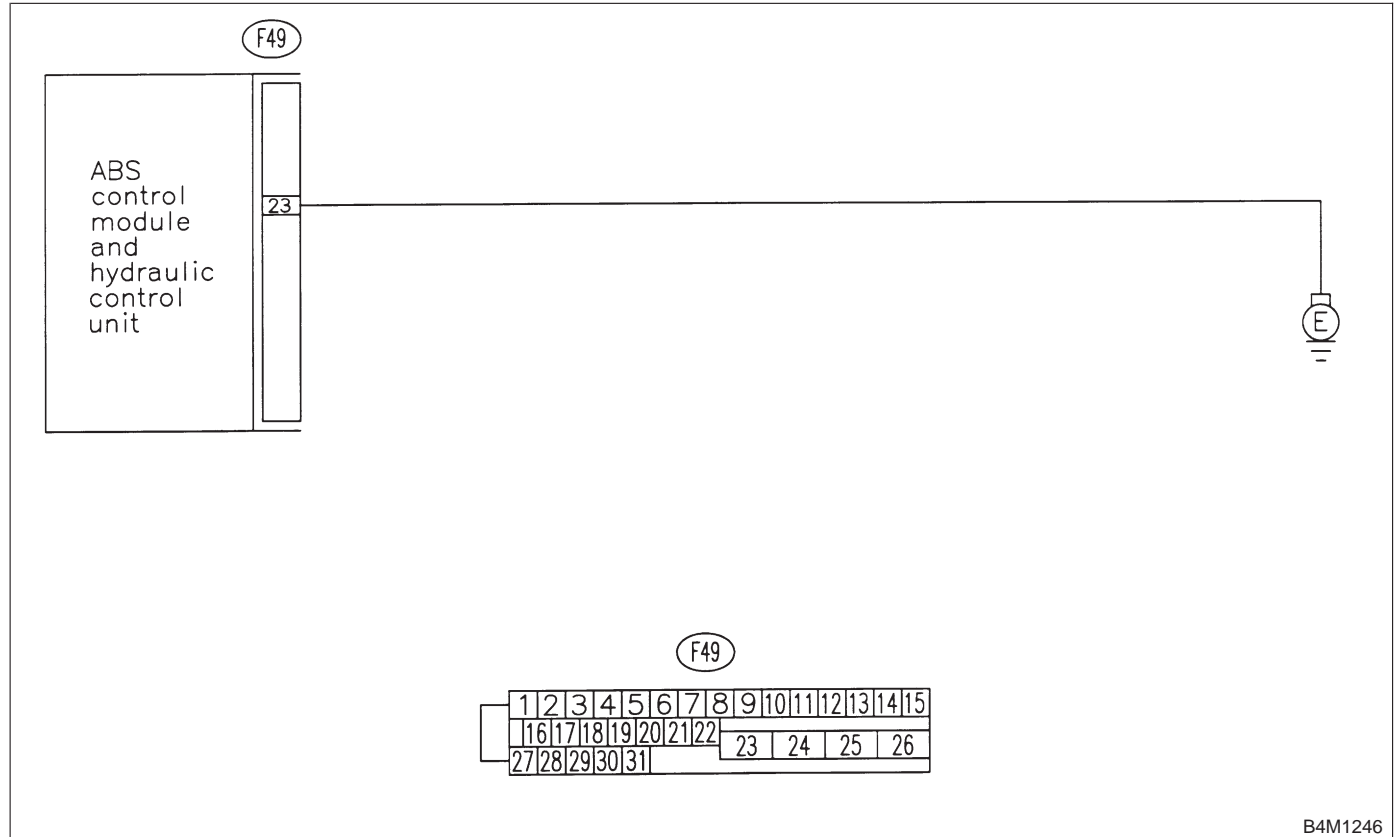

B4M1246

10V1 : CHECK GROUND CIRCUIT OF ABSCM&H/U.

- 1) Turn ignition switch to OFF.
- 2) Disconnect connector from ABSCM&H/U.
- 3) Measure resistance between ABSCM&H/U and chassis ground.

Connector & terminal

(F49) No. 23 — Chassis ground:

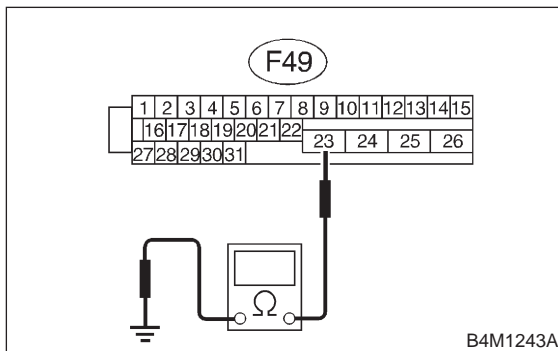

- CHECK** : *Is the resistance less than 0.5 Ω?*
- YES** : Go to step **10V2**.
- NO** : Repair ABSCM&H/U ground harness.

10V2 : CHECK POOR CONTACT IN CONNECTORS.

- CHECK** : *Is there poor contact in connectors between battery, ignition switch and ABSCM&H/U? <Ref. to FOREWORD [T3C1].>*
- YES** : Repair connector.
- NO** : Go to step **10V3**.

10V3 : CHECK SOURCES OF SIGNAL NOISE.

- CHECK** : *Is the car telephone or the wireless transmitter properly installed?*
- YES** : Go to step **10V4**.
- NO** : Properly install the car telephone or the wireless transmitter.

10V4 : CHECK SOURCES OF SIGNAL NOISE.

- CHECK** : *Are noise sources (such as an antenna) installed near the sensor harness?*
- YES** : Install the noise sources apart from the sensor harness.
- NO** : Go to step **10V5**.

10V5 : CHECK ABSCM&H/U.

- 1) Turn ignition switch to OFF.
 - 2) Connect all connectors.
 - 3) Erase the memory.
 - 4) Perform inspection mode.
 - 5) Read out the trouble code.
- CHECK** : *Is the same trouble code as in the current diagnosis still being output?*
 - YES** : Replace ABSCM&H/U.
 - NO** : Go to step **10V6**.

10V6 : CHECK ANY OTHER TROUBLE CODES APPEARANCE.

- CHECK** : *Are other trouble codes being output?*
- YES** : Proceed with the diagnosis corresponding to the trouble code.
- NO** : A temporary poor contact.

W: TROUBLE CODE 42 POWER SUPPLY VOLTAGE TOO LOW
— POWER SUPPLY VOLTAGE TOO LOW —

DIAGNOSIS:

- Power source voltage of the ABSCM&H/U is low.

TROUBLE SYMPTOM:

- ABS does not operate.

WIRING DIAGRAM:

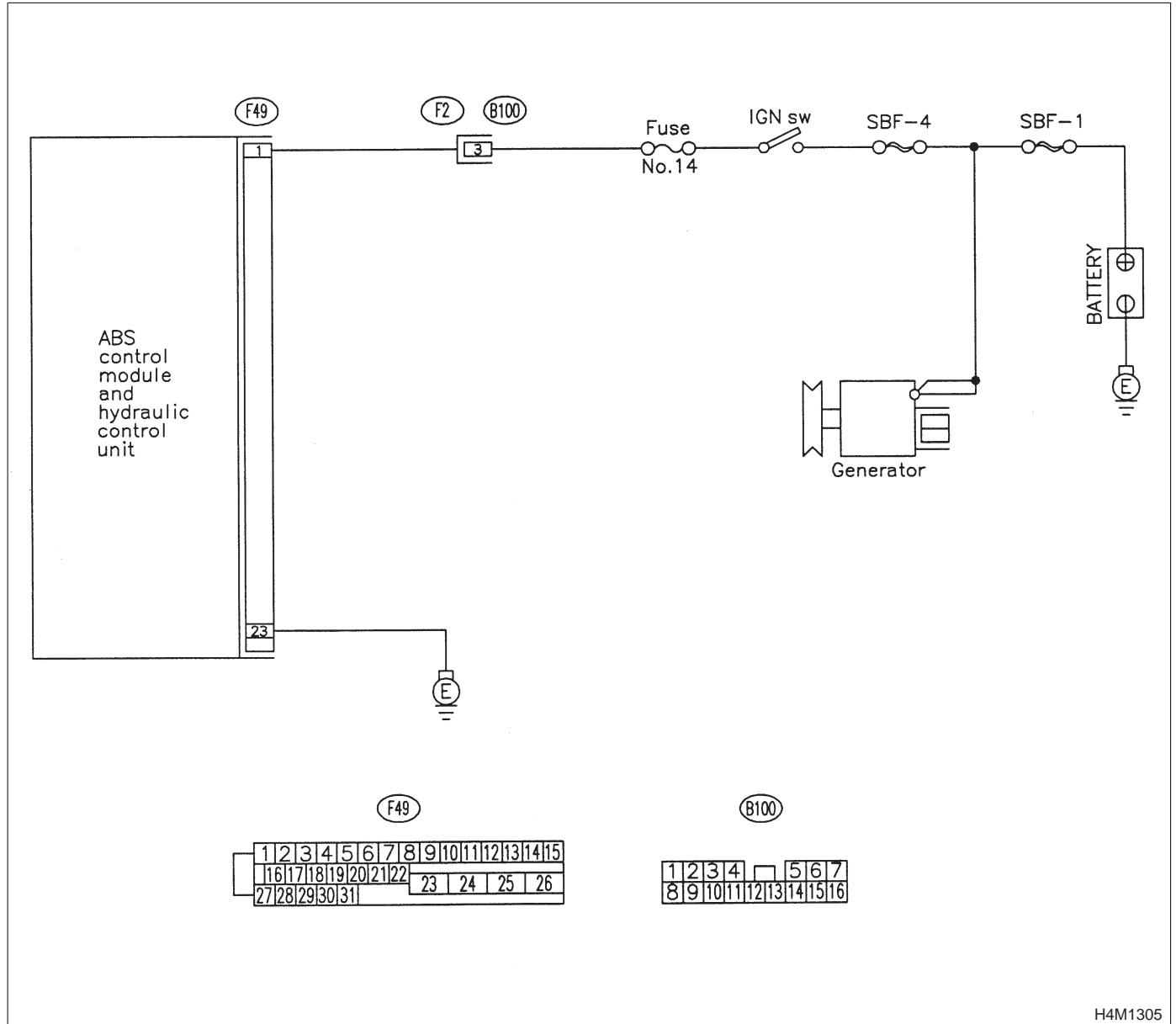

H4M1305

10W1 : CHECK GENERATOR.

- 1) Start engine.
- 2) Idling after warm-up.
- 3) Measure voltage between generator B terminal and chassis ground.

Terminal

Generator B terminal — Chassis ground:

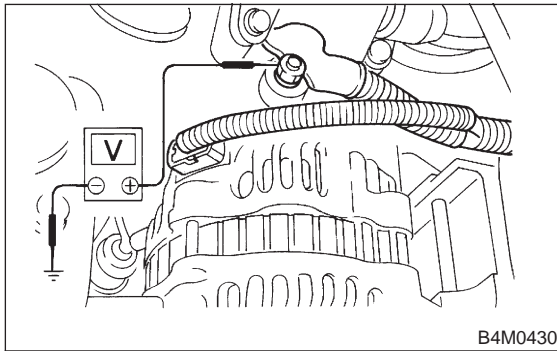

- CHECK** : **Is the voltage between 10 V and 15 V?**
- YES** : Go to step 10W2.
- NO** : Repair generator.

10W2 : CHECK BATTERY TERMINAL.

Turn ignition switch to OFF.

- CHECK** : **Are the positive and negative battery terminals tightly clamped?**
- YES** : Go to step 10W3.
- NO** : Tighten the clamp of terminal.

10W3 : CHECK INPUT VOLTAGE OF ABSCM&H/U.

- 1) Disconnect connector from ABSCM&H/U.
- 2) Run the engine at idle.
- 3) Measure voltage between ABSCM&H/U connector and chassis ground.

Connector & terminal

(F49) No. 1 (+) — Chassis ground (-):

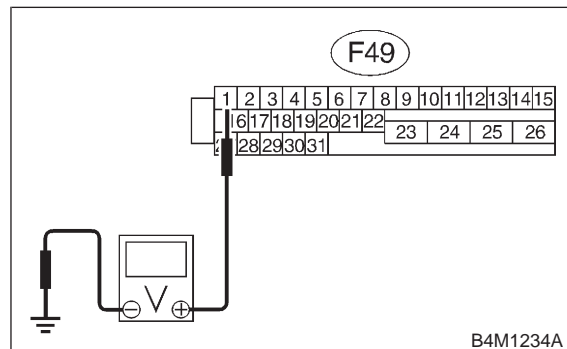

- CHECK** : **Is the voltage between 10 V and 15 V?**
- YES** : Go to step 10W4.
- NO** : Repair harness connector between battery, ignition switch and ABSCM&H/U.

10W4 : CHECK GROUND CIRCUIT OF ABSCM&H/U.

- 1) Turn ignition switch to OFF.
- 2) Measure resistance between ABSCM&H/U connector and chassis ground.

Connector & terminal

(F49) No. 23 — Chassis ground:

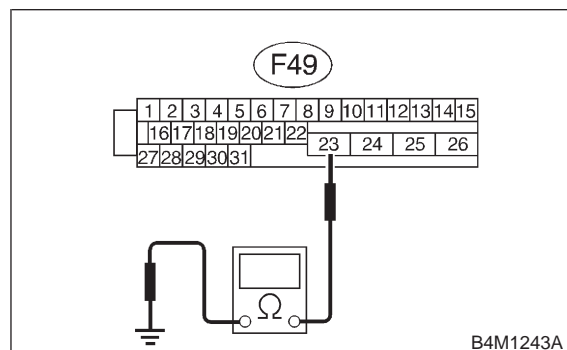

- CHECK** : **Is the resistance less than 0.5 Ω?**
- YES** : Go to step 10W5.
- NO** : Repair ABSCM&H/U ground harness.

10W5 : CHECK POOR CONTACT IN CONNECTORS.

CHECK : *Is there poor contact in connectors between generator, battery and ABSCM&H/U? <Ref. to FOREWORD [T3C1].>*

YES : Repair connector.

NO : Go to step **10W6**.

10W6 : CHECK ABSCM&H/U.

- 1) Connect all connectors.
- 2) Erase the memory.
- 3) Perform inspection mode.
- 4) Read out the trouble code.

CHECK : *Is the same trouble code as in the current diagnosis still being output?*

YES : Replace ABSCM&H/U.

NO : Go to step **10W7**.

10W7 : CHECK ANY OTHER TROUBLE CODES APPEARANCE.

CHECK : *Are other trouble codes being output?*

YES : Proceed with the diagnosis corresponding to the trouble code.

NO : A temporary poor contact.

MEMO:

X: TROUBLE CODE 42 POWER SUPPLY VOLTAGE TOO HIGH
— POWER SUPPLY VOLTAGE TOO HIGH —

DIAGNOSIS:

- Power source voltage of the ABSCM&H/U is high.

TROUBLE SYMPTOM:

- ABS does not operate.

WIRING DIAGRAM:

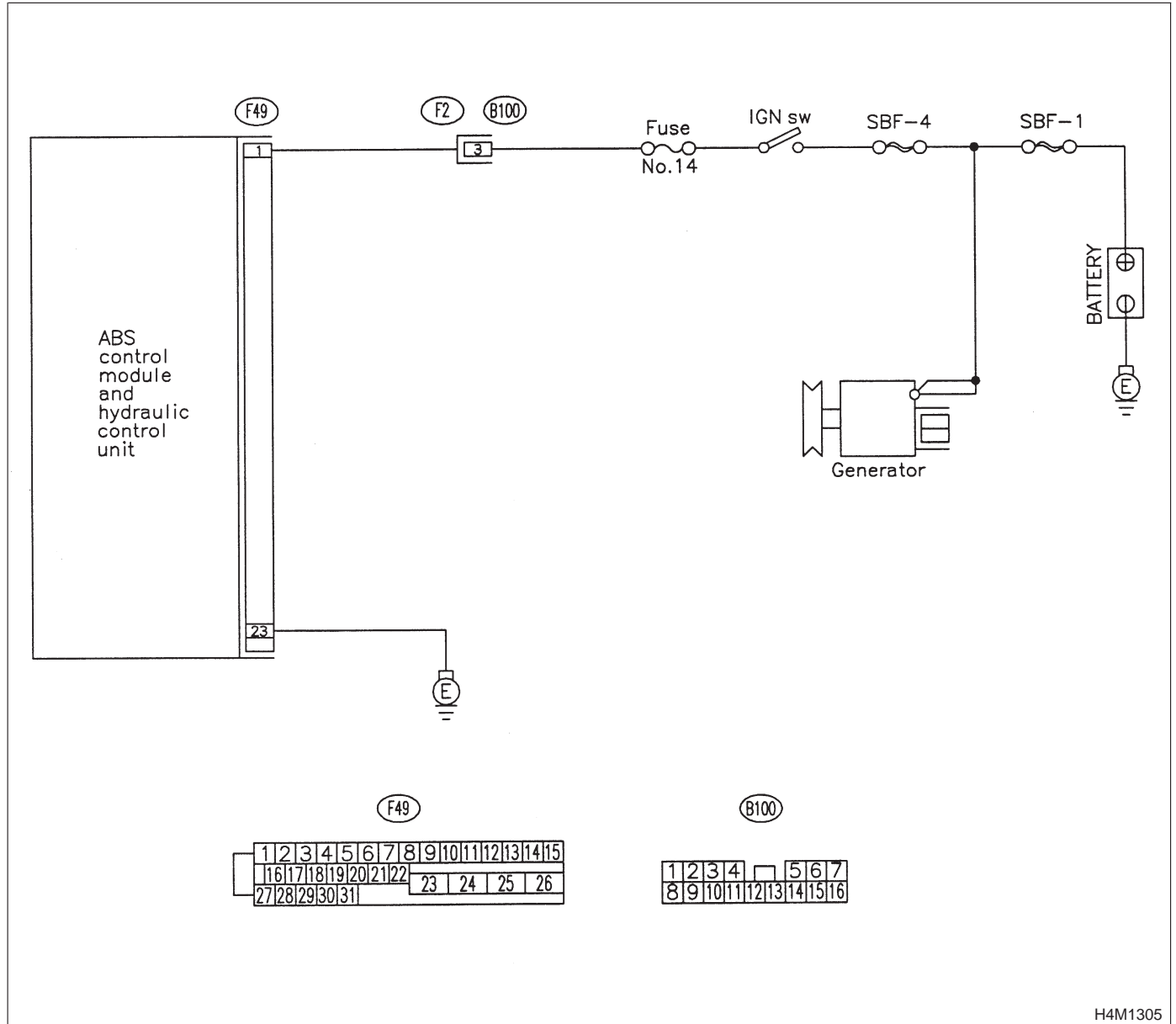

H4M1305

10X1 : CHECK GENERATOR.

- 1) Start engine.
- 2) Idling after warm-up.
- 3) Measure voltage between generator B terminal and chassis ground.

Terminal

Generator B terminal — Chassis ground:

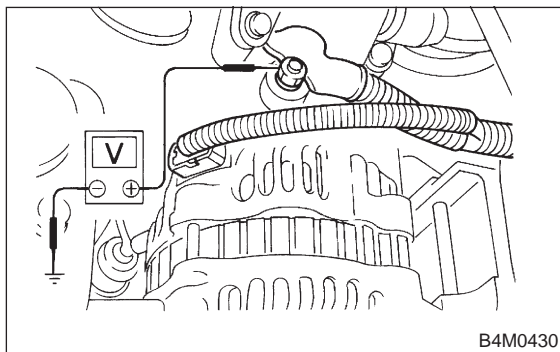

- CHECK** : **Is the voltage between 10 V and 17 V?**
- YES** : Go to step 10X2.
- NO** : Repair generator.

10X2 : CHECK BATTERY TERMINAL.

Turn ignition switch to OFF.

- CHECK** : **Are the positive and negative battery terminals tightly clamped?**
- YES** : Go to step 10X3.
- NO** : Tighten the clamp of terminal.

10X3 : CHECK INPUT VOLTAGE OF ABSCM&H/U.

- 1) Disconnect connector from ABSCM&H/U.
- 2) Run the engine at idle.
- 3) Measure voltage between ABSCM&H/U connector and chassis ground.

Connector & terminal

(F49) No. 1 (+) — Chassis ground (-):

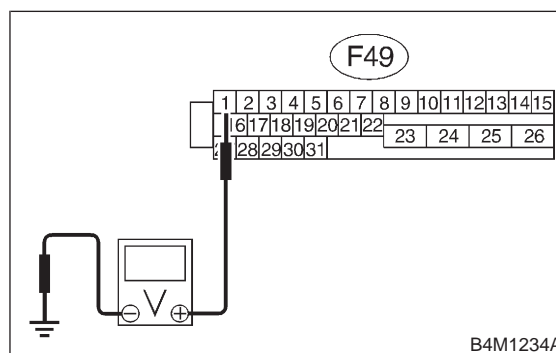

- CHECK** : **Is the voltage between 10 V and 17 V?**
- YES** : Go to step 10X4.
- NO** : Repair harness connector between battery, ignition switch and ABSCM&H/U.

10X4 : CHECK GROUND CIRCUIT OF ABSCM&H/U.

- 1) Turn ignition switch to OFF.
- 2) Measure resistance between ABSCM&H/U connector and chassis ground.

Connector & terminal

(F49) No. 23 — Chassis ground:

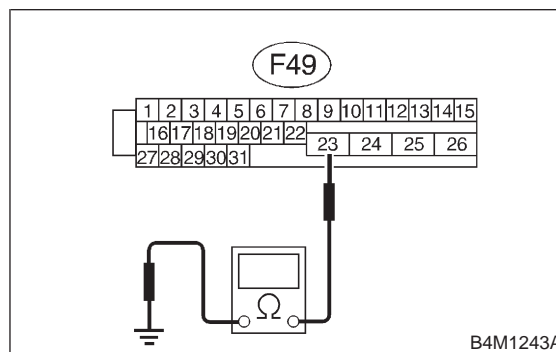

- CHECK** : **Is the resistance less than 0.5 Ω?**
- YES** : Go to step 10X5.
- NO** : Repair ABSCM&H/U ground harness.

10X5 : CHECK POOR CONTACT IN CONNECTORS.

CHECK : *Is there poor contact in connectors between generator, battery and ABSCM&H/U? <Ref. to FOREWORD [T3C1].>*

YES : Repair connector.

NO : Go to step **10X6**.

10X6 : CHECK ABSCM&H/U.

- 1) Connect all connectors.
- 2) Erase the memory.
- 3) Perform inspection mode.
- 4) Read out the trouble code.

CHECK : *Is the same trouble code as in the current diagnosis still being output?*

YES : Replace ABSCM&H/U.

NO : Go to step **10X7**.

10X7 : CHECK ANY OTHER TROUBLE CODES APPEARANCE.

CHECK : *Are other trouble codes being output?*

YES : Proceed with the diagnosis corresponding to the trouble code.

NO : A temporary poor contact.

MEMO:

Y: TROUBLE CODE 44 ABS-AT CONTROL (NON CONTROLLED)
— ABS-AT CONTROL (NON CONTROLLED) —

DIAGNOSIS:

- Combination of AT control faults

TROUBLE SYMPTOM:

- ABS does not operate.

WIRING DIAGRAM:

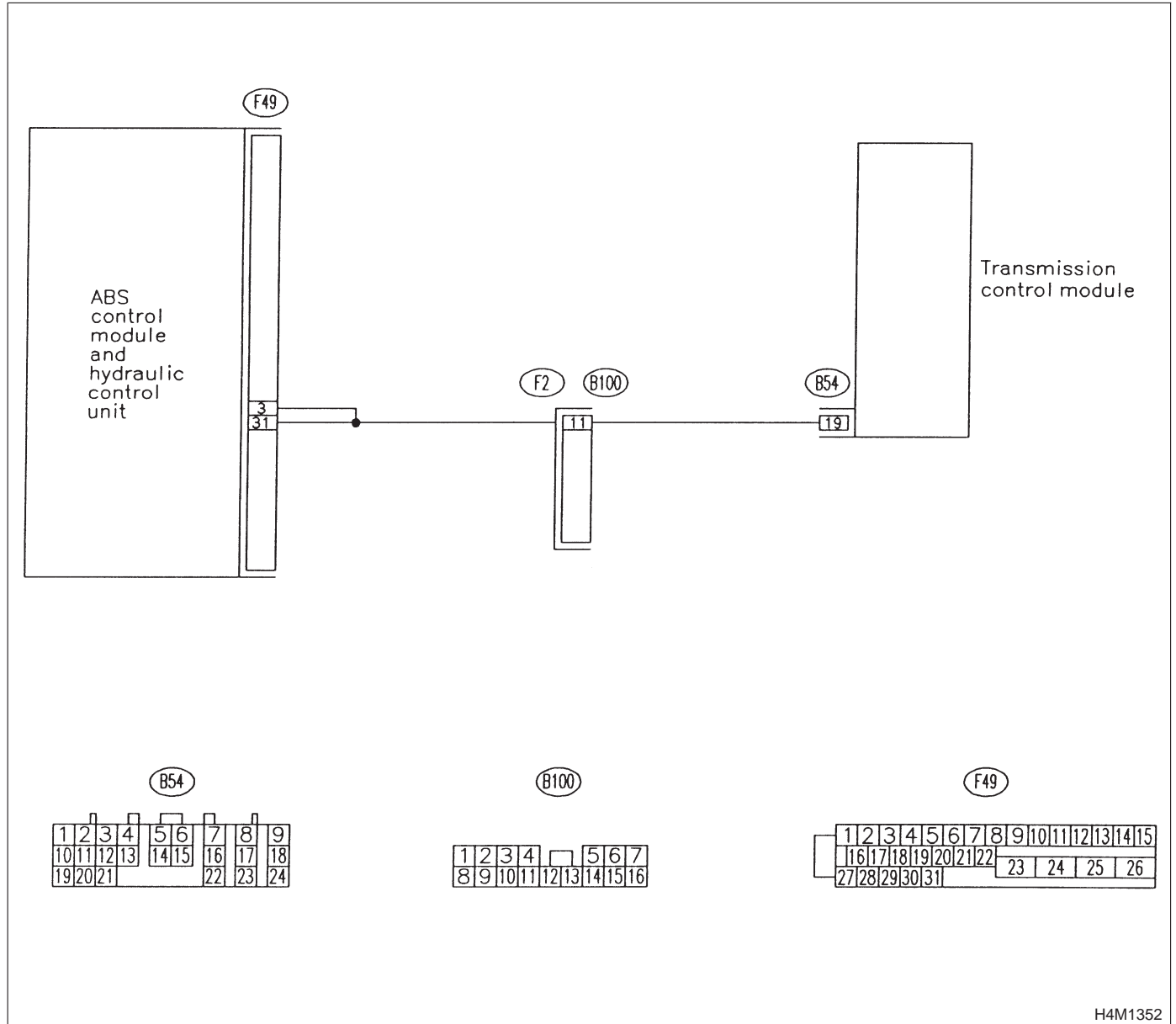

H4M1352

10Y1 : CHECK SPECIFICATIONS OF THE ABSCM&H/U.

Check specifications of the mark to the ABSCM&H/U.

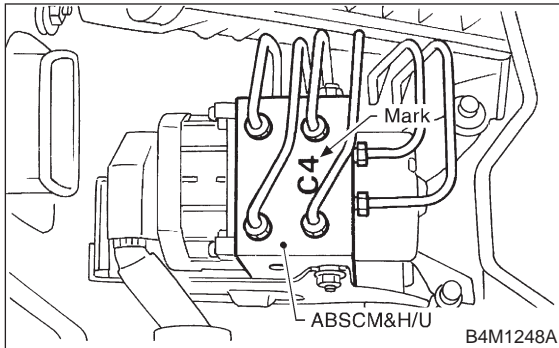

Mark	Model
C5	AWD AT
C6	AWD MT

CHECK : Is an ABSCM&H/U for AT model installed on a MT model?

YES : Replace ABSCM&H/U.

NO : Go to step 10Y2.

10Y2 : CHECK GROUND SHORT OF HARNESS.

- 1) Turn ignition switch to OFF.
- 2) Disconnect two connectors from TCM.
- 3) Disconnect connector from ABSCM&H/U.
- 4) Measure resistance between ABSCM&H/U connector and chassis ground.

Connector & terminal
(F49) No. 3 — Chassis ground:

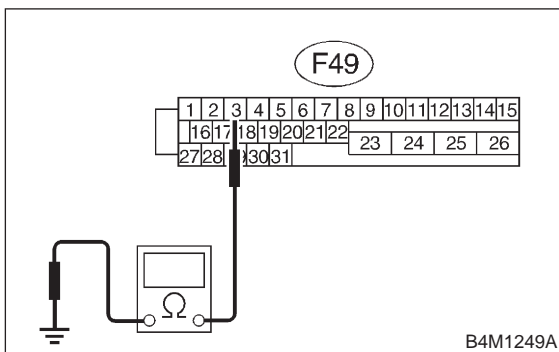

CHECK : Is the resistance more than 1 MΩ?

YES : Go to step 10Y3.

NO : Repair harness between TCM and ABSCM&H/U.

10Y3 : CHECK TCM.

- 1) Connect all connectors to TCM.
- 2) Turn ignition switch to ON.
- 3) Measure voltage between TCM connector terminal and chassis ground.

Connector & terminal
(B54) No. 19 (+) — Chassis ground (-):

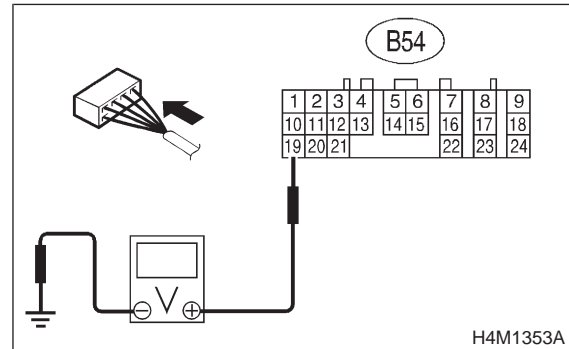

CHECK : Is the voltage between 10 V and 15 V?

YES : Go to step 10Y5.

NO : Go to step 10Y4.

10Y4 : CHECK AT.

CHECK : Is the AT functioning normally?

YES : Replace TCM.

NO : Repair AT.

10Y5 : CHECK OPEN CIRCUIT OF HARNESS.

Measure voltage between ABSCM&H/U connector and chassis ground.

Connector & terminal

(F49) No. 3 (+) — Chassis ground (-):

(F49) No. 31 (+) — Chassis ground (-):

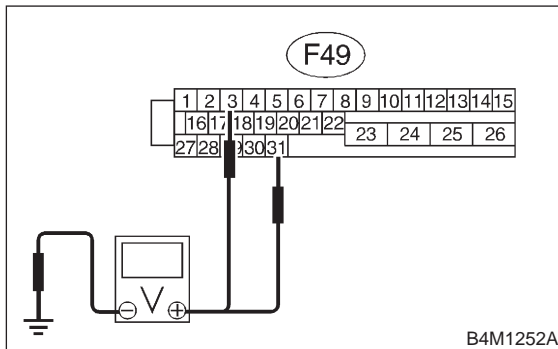

CHECK : **Is the voltage more than 10 V?**

YES : Go to step **10Y6**.

NO : Repair harness/connector between AT control module and ABSCM&H/U.

10Y6 : CHECK POOR CONTACT IN CONNECTORS.

CHECK : **Is there poor contact in connectors between AT control module and ABSCM&H/U? <Ref. to FOREWORD [T3C1].>**

YES : Repair connector.

NO : Go to step **10Y7**.

10Y7 : CHECK ABSCM&H/U.

- 1) Connect all connectors.
- 2) Erase the memory.
- 3) Perform inspection mode.
- 4) Read out the trouble code.

CHECK : **Is the same trouble code as in the current diagnosis still being output?**

YES : Replace ABSCM&H/U.

NO : Go to step **10Y8**.

10Y8 : CHECK ANY OTHER TROUBLE CODES APPEARANCE.

CHECK : **Are other trouble codes being output?**

YES : Proceed with the diagnosis corresponding to the trouble code.

NO : A temporary poor contact.

MEMO:

Z: TROUBLE CODE 44 ABS-AT CONTROL (CONTROLLED)
— ABS-AT CONTROL (CONTROLLED) —

DIAGNOSIS:

- Combination of AT control faults

TROUBLE SYMPTOM:

- ABS does not operate.

WIRING DIAGRAM:

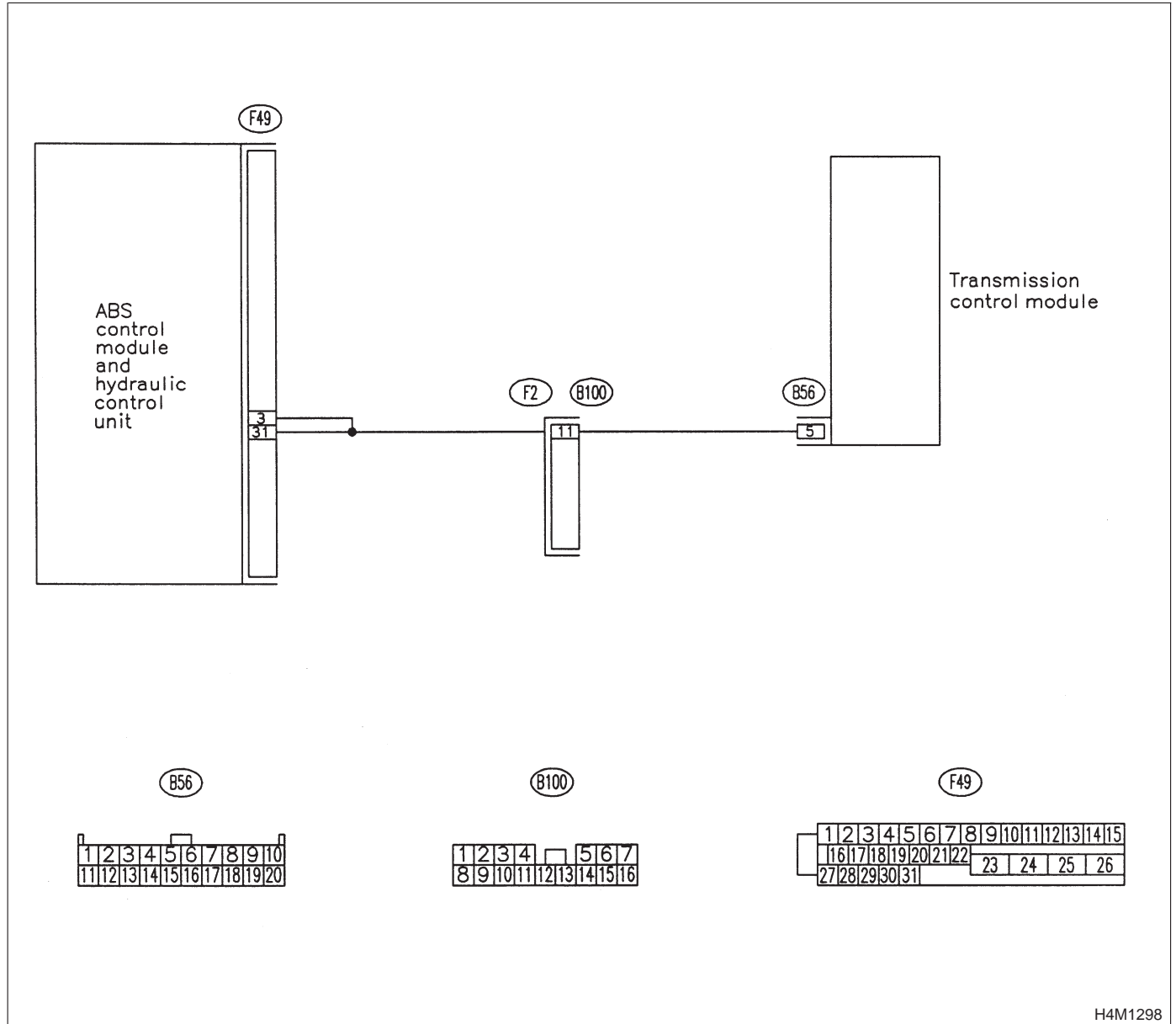

H4M1298

10Z1 : CHECK BATTERY SHORT OF HARNESS.

- 1) Turn ignition switch to OFF.
- 2) Disconnect two connectors from AT control module.
- 3) Disconnect connector from ABSCM&H/U.
- 4) Measure voltage between ABSCM&H/U connector and chassis ground.

Connector & terminal

(F49) No. 3 (+) — Chassis ground (-):

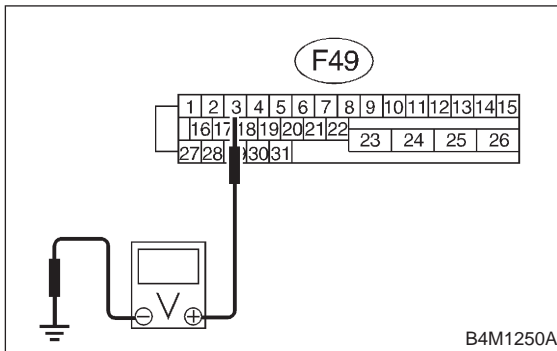

- CHECK** : *Is the voltage less than 1 V?*
- YES** : Go to step **10Z2**.
- NO** : Repair harness between AT control module and ABSCM&H/U.

10Z2 : CHECK BATTERY SHORT OF HARNESS.

- 1) Turn ignition switch to ON.
- 2) Measure voltage between ABSCM&H/U connector and chassis ground.

Connector & terminal

(F49) No. 3 (+) — Chassis ground (-):

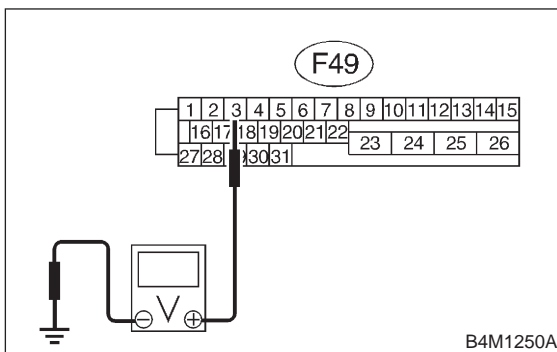

- CHECK** : *Is the voltage less than 1 V?*
- YES** : Go to step **10Z3**.
- NO** : Repair harness between AT control module and ABSCM&H/U.

10Z3 : CHECK OPEN CIRCUIT OF HARNESS.

- 1) Turn ignition switch to OFF.
- 2) Connect all connectors to TCM.
- 3) Turn ignition switch to ON.
- 4) Measure voltage between ABSCM&H/U connector and chassis ground.

Connector & terminal

(F49) No. 3 (+) — Chassis ground (-):

(F49) No. 31 (+) — Chassis ground (-):

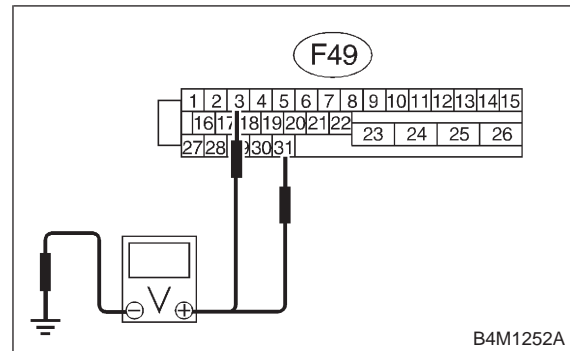

- CHECK** : *Is the voltage between 10 V and 13 V?*
- YES** : Go to step **10Z4**.
- NO** : Repair harness/connector between TCM and ABSCM&H/U.

10Z4 : CHECK POOR CONTACT IN CONNECTORS.

Turn ignition switch to OFF.

CHECK : *Is there poor contact in connectors between AT control module and ABSCM&H/U? <Ref. to FOREWORD [T3C1].>*

- YES** : Repair connector.
- NO** : Go to step **10Z5**.

10Z5 : CHECK ABSCM&H/U.

- 1) Connect all connectors.
- 2) Erase the memory.
- 3) Perform inspection mode.
- 4) Read out the trouble code.

CHECK : *Is the same trouble code as in the current diagnosis still being output?*

- YES** : Replace ABSCM&H/U.
- NO** : Go to step **10Z6**.

10Z6 : CHECK ANY OTHER TROUBLE CODES APPEARANCE.

- CHECK** : *Are other trouble codes being output?*
- YES** : Proceed with the diagnosis corresponding to the trouble code.
- NO** : A temporary poor contact.

MEMO:

AA: TROUBLE CODE 51 VALVE RELAY MALFUNCTION
— VALVE RELAY MALFUNCTION —

DIAGNOSIS:

- Faulty valve relay

TROUBLE SYMPTOM:

- ABS does not operate.

WIRING DIAGRAM:

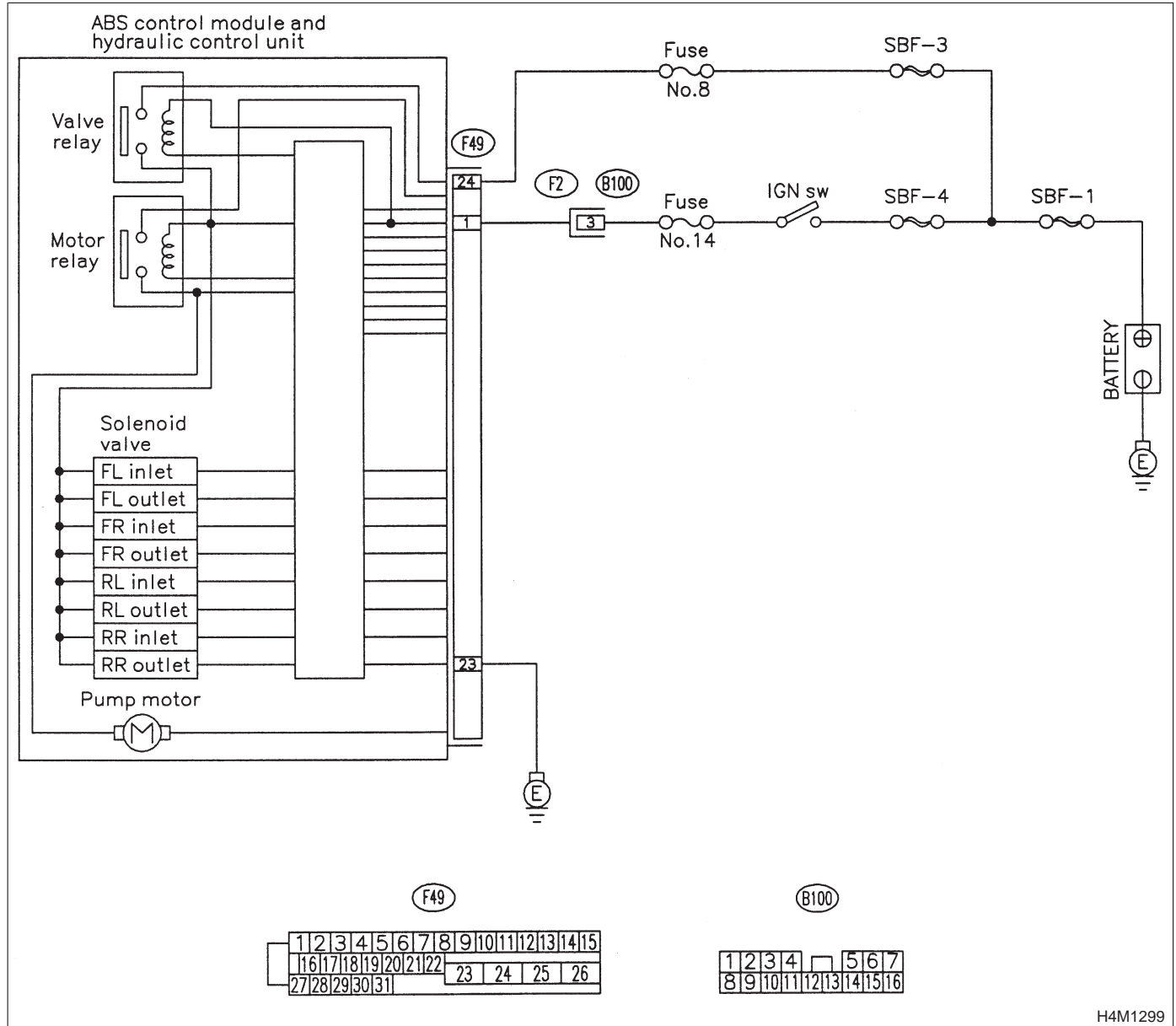

10AA1 : CHECK INPUT VOLTAGE OF ABSCM&H/U.

- 1) Turn ignition switch to OFF.
- 2) Disconnect connector from ABSCM&H/U.
- 3) Run the engine at idle.
- 4) Measure voltage between ABSCM&H/U connector and chassis ground.

Connector & terminal

(F49) No. 1 (+) — Chassis ground (-):

(F49) No. 24 (+) — Chassis ground (-):

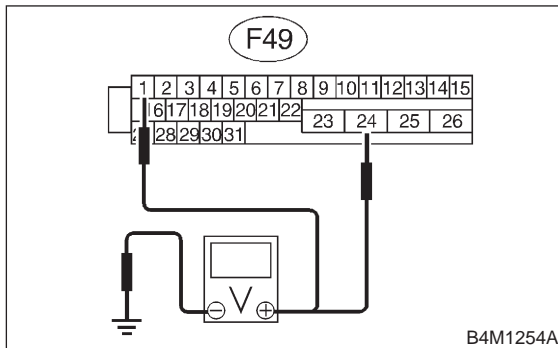

CHECK : **Is the voltage between 10 V and 15 V?**

YES : Go to step 10AA2.

NO : Repair harness connector between battery and ABSCM&H/U.

10AA2 : CHECK GROUND CIRCUIT OF ABSCM&H/U.

- 1) Turn ignition switch to OFF.
- 2) Measure resistance between ABSCM&H/U connector and chassis ground.

Connector & terminal

(F49) No. 23 — Chassis ground:

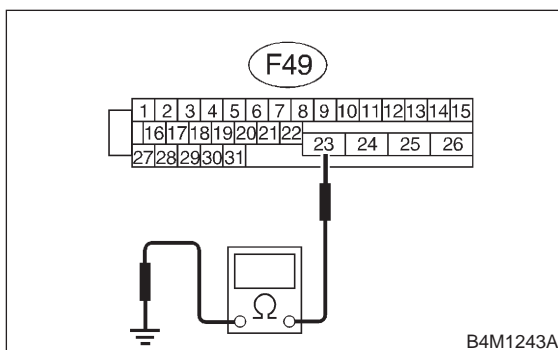

CHECK : **Is the resistance less than 0.5 Ω?**

YES : Go to step 10AA3.

NO : Repair ABSCM&H/U ground harness.

10AA3 : CHECK POOR CONTACT IN CONNECTORS.

CHECK : **Is there poor contact in connectors between generator, battery and ABSCM&H/U? <Ref. to FOREWORD [T3C1].>**

YES : Repair connector.

NO : Go to step 10AA4.

10AA4 : CHECK ABSCM&H/U.

- 1) Connect all connectors.
- 2) Erase the memory.
- 3) Perform inspection mode.
- 4) Read out the trouble code.

CHECK : **Is the same trouble code as in the current diagnosis still being output?**

YES : Replace ABSCM&H/U.

NO : Go to step 10AA5.

10AA5 : CHECK ANY OTHER TROUBLE CODES APPEARANCE.

CHECK : **Are other trouble codes being output?**

YES : Proceed with the diagnosis corresponding to the trouble code.

NO : A temporary poor contact.

AB: TROUBLE CODE 51 VALVE RELAY ON FAILURE
— VALVE RELAY ON FAILURE —

DIAGNOSIS:

- Faulty valve relay

TROUBLE SYMPTOM:

- ABS does not operate.

WIRING DIAGRAM:

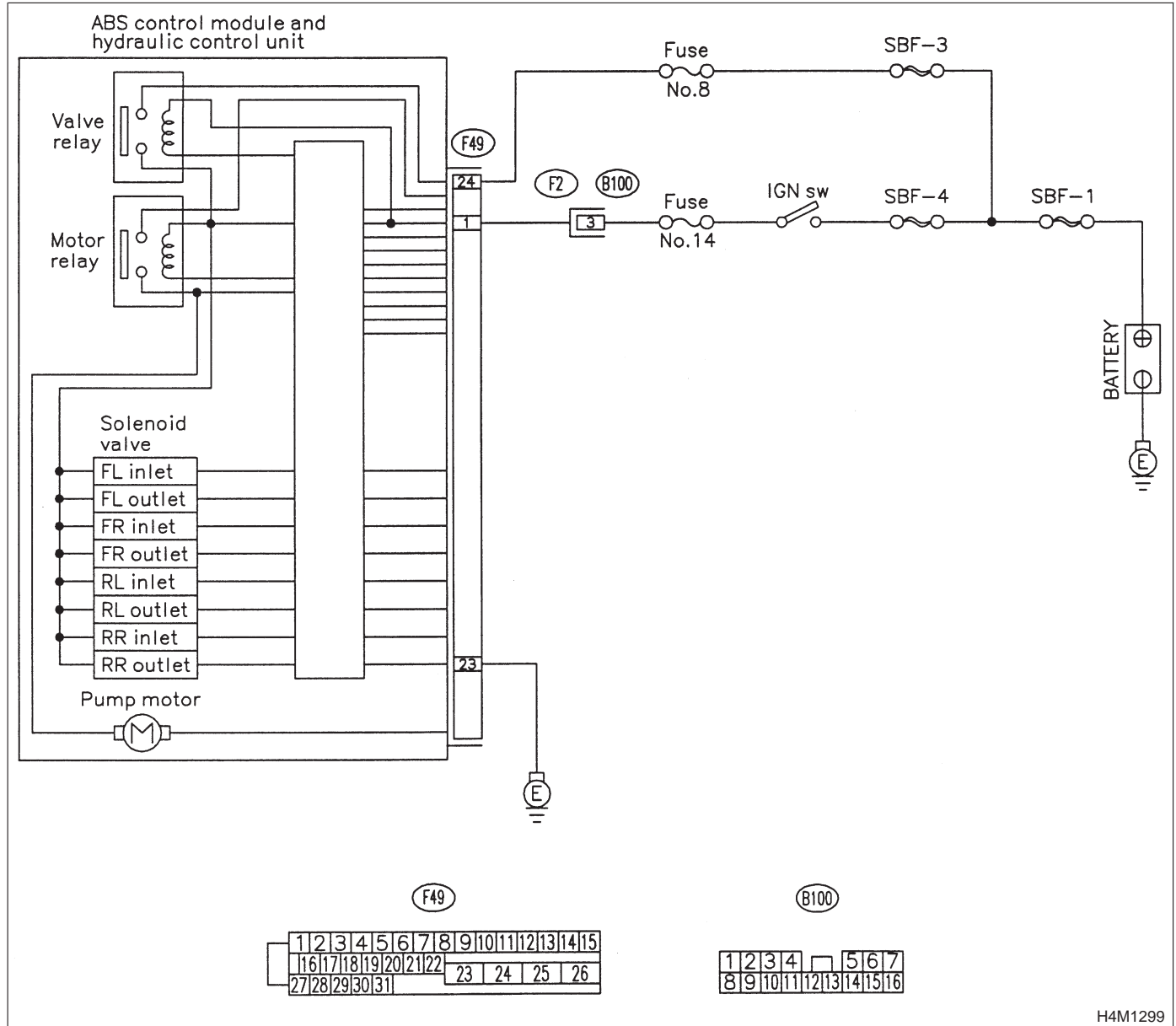

10AB1 : CHECK VALVE RELAY IN ABSCM&H/U.

Measure resistance between ABSCM&H/U terminals.

Terminals

No. 23 (+) — No. 24 (-):

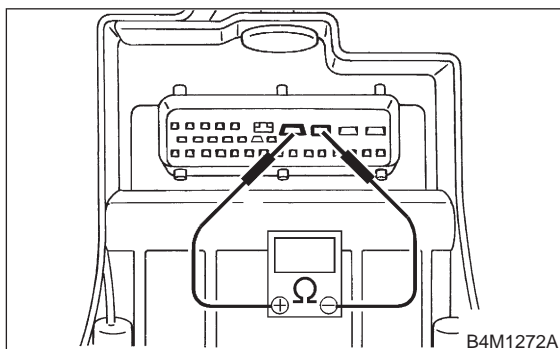

- CHECK** : *Is the resistance more than 1 MΩ?*
YES : Go to step **10AB2**.
NO : Replace ABSCM&H/U.

10AB2 : CHECK POOR CONTACT IN CONNECTORS.

- CHECK** : *Is there poor contact in connectors between generator, battery and ABSCM&H/U? <Ref. to FOREWORD [T3C1].>*
YES : Repair connector.
NO : Go to step **10AB3**.

10AB3 : CHECK ABSCM&H/U.

- 1) Connect all connectors.
- 2) Erase the memory.
- 3) Perform inspection mode.
- 4) Read out the trouble code.

- CHECK** : *Is the same trouble code as in the current diagnosis still being output?*
YES : Replace ABSCM&H/U.
NO : Go to step **10AB4**.

10AB4 : CHECK ANY OTHER TROUBLE CODES APPEARANCE.

- CHECK** : *Are other trouble codes being output?*
YES : Proceed with the diagnosis corresponding to the trouble code.
NO : A temporary poor contact.

AC: TROUBLE CODE 52 OPEN CIRCUIT IN MOTOR RELAY CIRCUIT — OPEN CIRCUIT IN MOTOR RELAY CIRCUIT —

DIAGNOSIS:

- Faulty motor
- Faulty motor relay
- Faulty harness connector

TROUBLE SYMPTOM:

- ABS does not operate.

WIRING DIAGRAM:

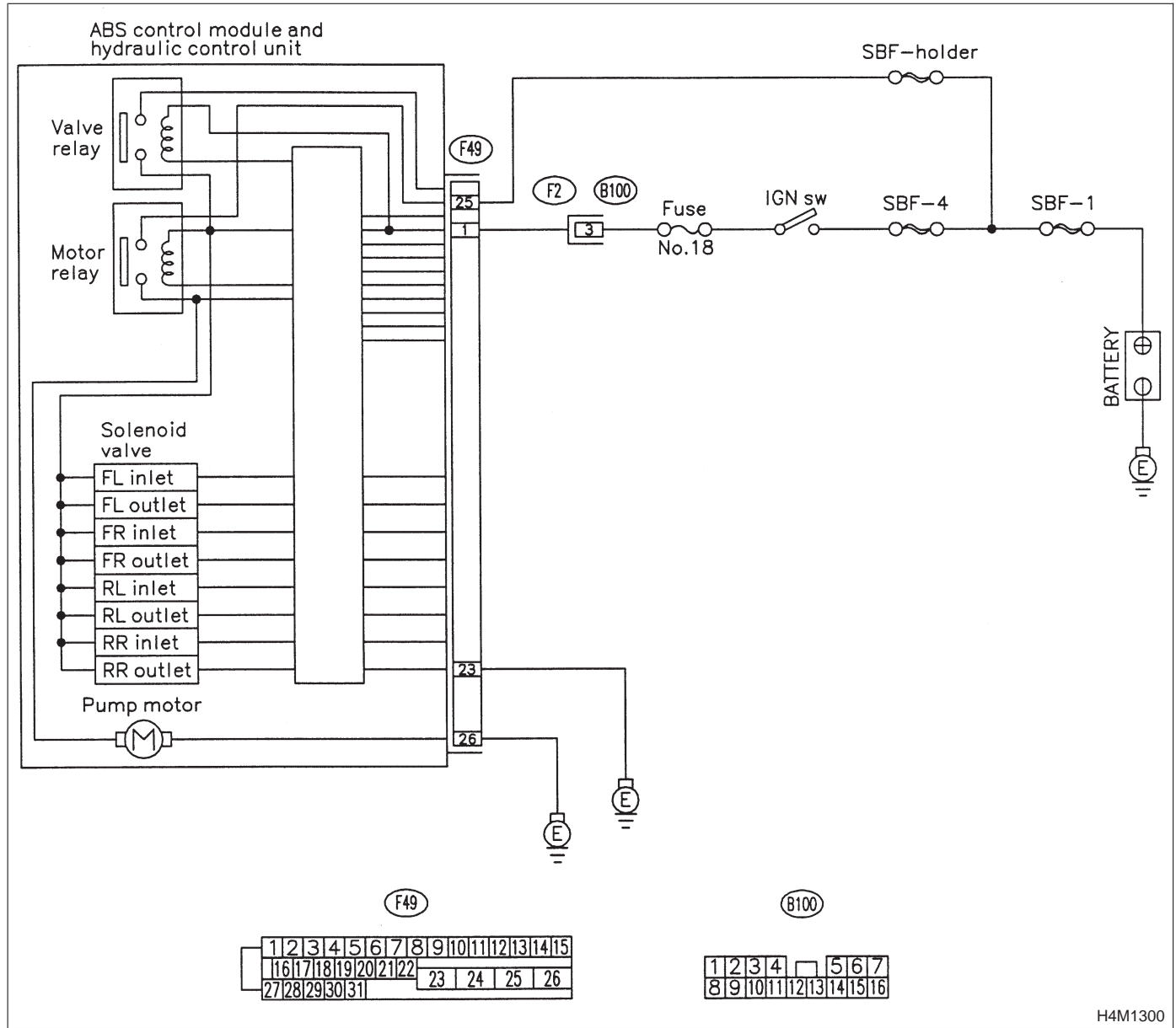

H4M1300

10AC1 : CHECK INPUT VOLTAGE OF ABSCM&H/U.

- 1) Turn ignition switch to OFF.
- 2) Disconnect connector from ABSCM&H/U.
- 3) Turn ignition switch to ON.
- 4) Measure voltage between ABSCM&H/U connector and chassis ground.

Connector & terminal

(F49) No. 25 (+) — Chassis ground (-):

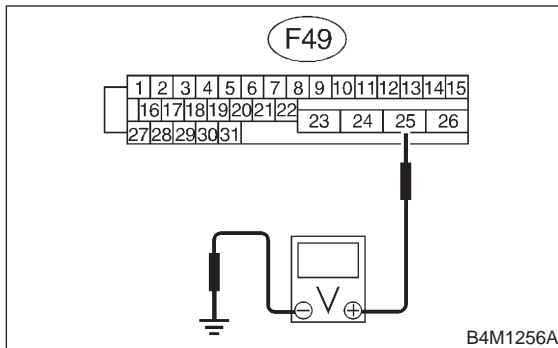

- CHECK** : *Is the voltage between 10 V and 13 V?*
- YES** : Go to step 10AC2.
- NO** : Repair harness/connector between battery and ABSCM&H/U and check fuse SBF-holder.

10AC2 : CHECK GROUND CIRCUIT OF MOTOR.

- 1) Turn ignition switch to OFF.
- 2) Measure resistance between ABSCM&H/U connector and chassis ground.

Connector & terminal

(F49) No. 26 — Chassis ground:

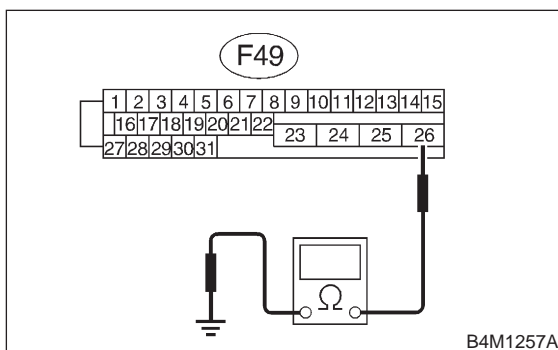

- CHECK** : *Is the resistance less than 0.5 Ω?*
- YES** : Go to step 10AC3.
- NO** : Repair ABSCM&H/U ground harness.

10AC3 : CHECK MOTOR OPERATION.

Operate the sequence control. <Ref. to 4-4 [W14D0].>

NOTE:

Use the diagnosis connector to operate the sequence control.

- CHECK** : *Can motor revolution noise (buzz) be heard when carrying out the check sequence?*
- YES** : Go to step 10AC4.
- NO** : Replace ABSCM&H/U.

10AC4 : CHECK POOR CONTACT IN CONNECTORS.

Turn ignition switch to OFF.

- CHECK** : *Is there poor contact in connector between hydraulic unit, relay box and ABSCM&H/U? <Ref. to FOREWORD [T3C1].>*
- YES** : Repair connector.
- NO** : Go to step 10AC5.

10AC5 : CHECK ABSCM&H/U.

- 1) Connect all connectors.
- 2) Erase the memory.
- 3) Perform inspection mode.
- 4) Read out the trouble code.

- CHECK** : *Is the same trouble code as in the current diagnosis still being output?*
- YES** : Replace ABSCM&H/U.
- NO** : Go to step 10AC6.

10AC6 : CHECK ANY OTHER TROUBLE CODES APPEARANCE.

- CHECK** : *Are other trouble codes being output?*
- YES** : Proceed with the diagnosis corresponding to the trouble code.
- NO** : A temporary poor contact.

AD: TROUBLE CODE 52 MOTOR RELAY ON FAILURE
— MOTOR RELAY ON FAILURE —

DIAGNOSIS:

- Faulty motor
- Faulty motor relay
- Faulty harness connector

TROUBLE SYMPTOM:

- ABS does not operate.

WIRING DIAGRAM:

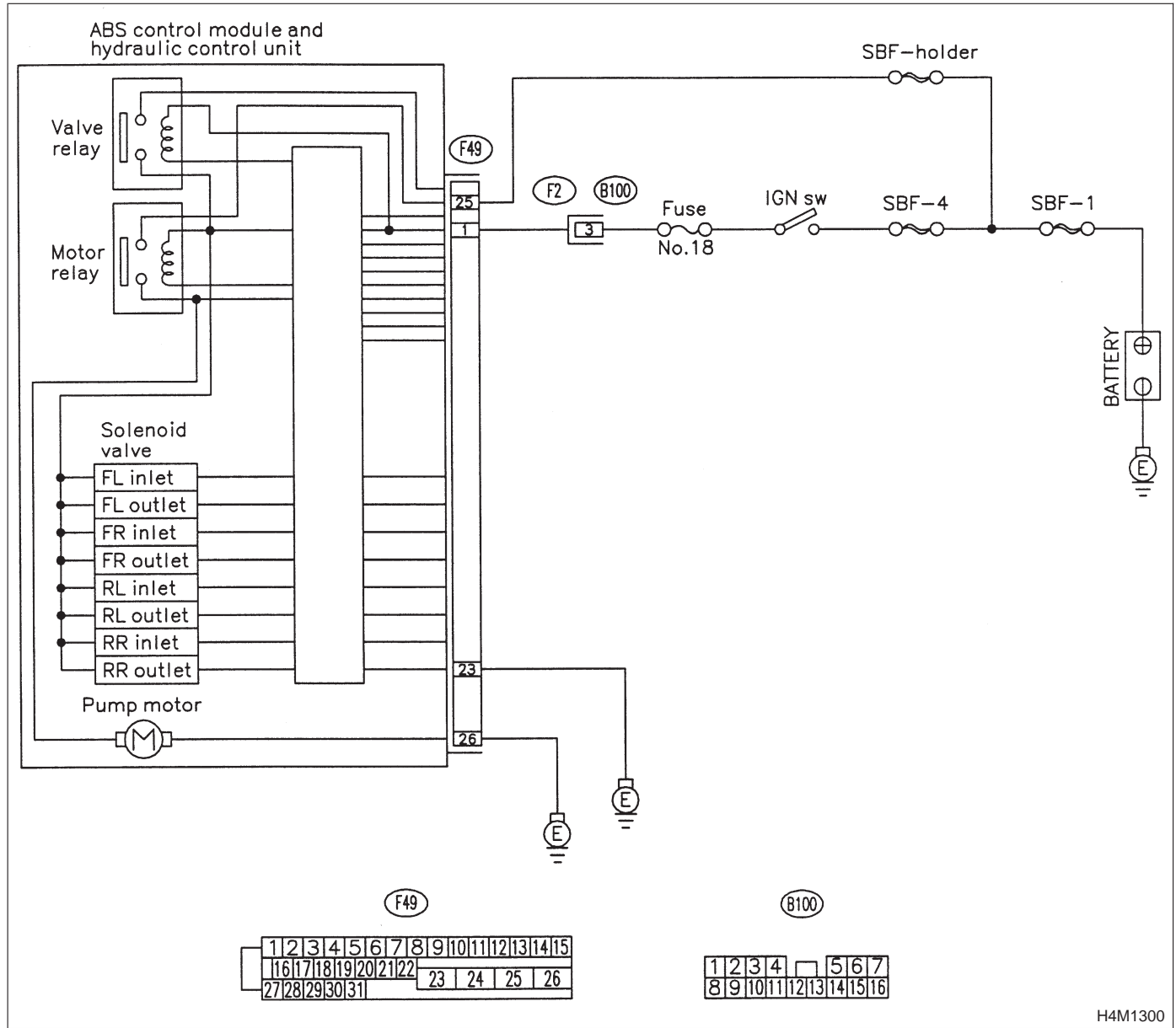

H4M1300

10AD1 : CHECK MOTOR RELAY IN ABSCM&H/U.

Measure resistance between ABSCM&H/U terminals.

Terminals

No. 25 — No. 26:

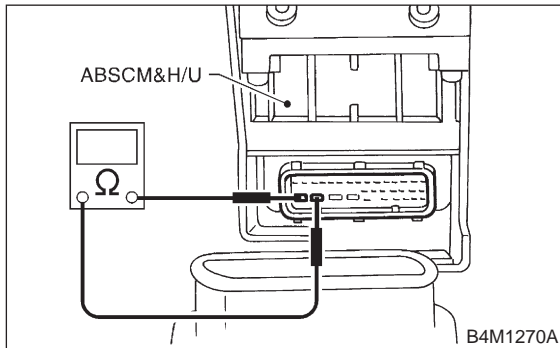

- CHECK** : *Is the resistance more than 1 MΩ?*
- YES** : Go to step 10AD2.
- NO** : Replace ABSCM&H/U.

10AD2 : CHECK MOTOR OPERATION.

Operate the sequence control. <Ref. to 4-4 [W14D0].>

NOTE:

Use the diagnosis connector to operate the sequence control.

- CHECK** : *Can motor revolution noise (buzz) be heard when carrying out the sequence control?*
- YES** : Go to step 10AD3.
- NO** : Replace ABSCM&H/U.

10AD3 : CHECK POOR CONTACT IN CONNECTORS.

Turn ignition switch to OFF.

- CHECK** : *Is there poor contact in connector between hydraulic unit, relay box and ABSCM&H/U? <Ref. to FOREWORD [T3C1].>*
- YES** : Repair connector.
- NO** : Go to step 10AD4.

10AD4 : CHECK ABSCM&H/U.

- 1) Connect all connectors.
- 2) Erase the memory.
- 3) Perform inspection mode.
- 4) Read out the trouble code.

- CHECK** : *Is the same trouble code as in the current diagnosis still being output?*
- YES** : Replace ABSCM&H/U.
- NO** : Go to step 10AD5.

10AD5 : CHECK ANY OTHER TROUBLE CODES APPEARANCE.

- CHECK** : *Are other trouble codes being output?*
- YES** : Proceed with the diagnosis corresponding to the trouble code.
- NO** : A temporary poor contact.

**AE: TROUBLE CODE 52 MOTOR MALFUNCTION
— MOTOR MALFUNCTION —**

DIAGNOSIS:

- Faulty motor
- Faulty motor relay
- Faulty harness connector

TROUBLE SYMPTOM:

- ABS does not operate.

WIRING DIAGRAM:

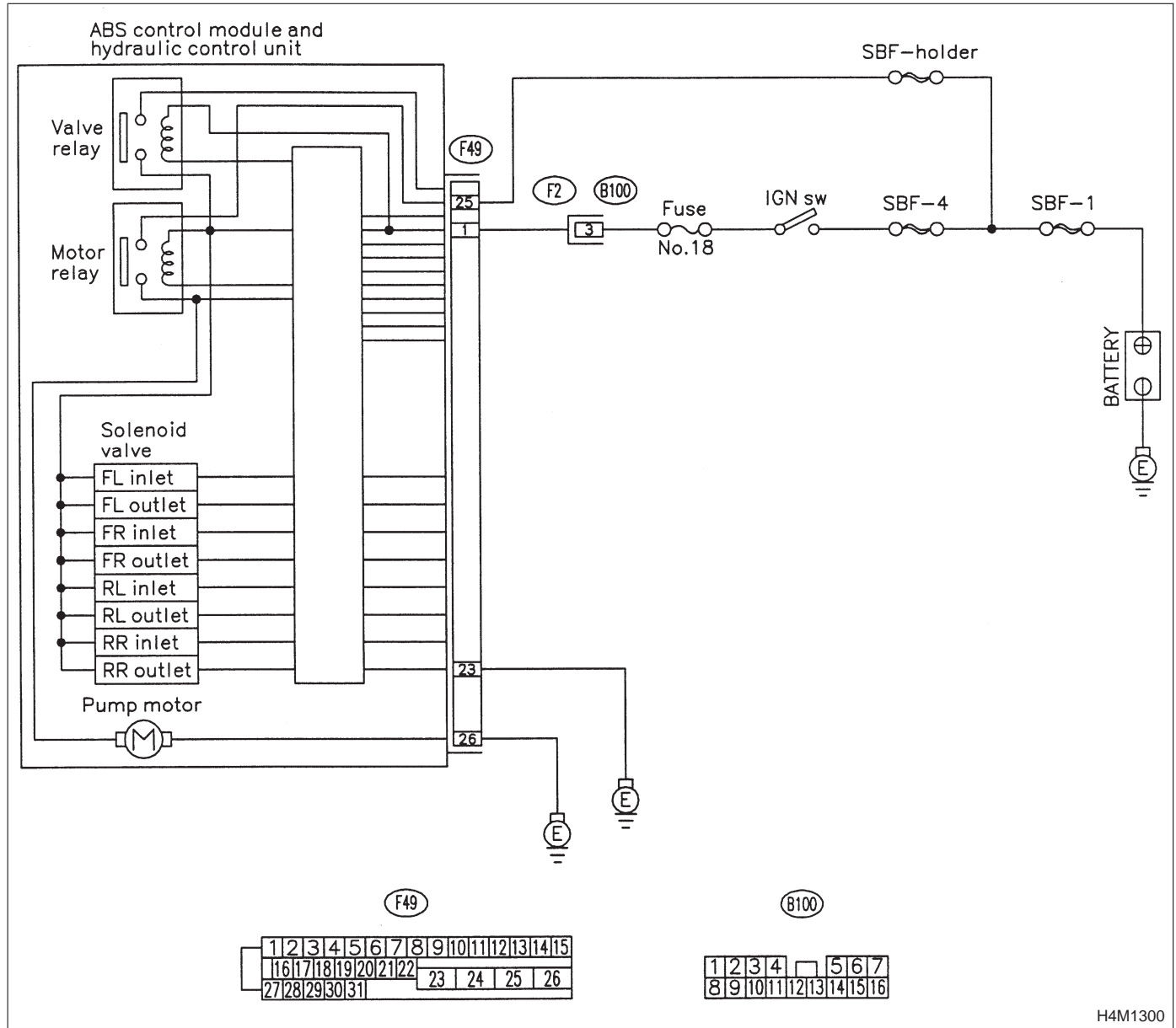

H4M1300

10AE1 : CHECK INPUT VOLTAGE OF ABSCM&H/U.

- 1) Turn ignition switch to OFF.
- 2) Disconnect connector from ABSCM&H/U.
- 3) Turn ignition switch to ON.
- 4) Measure voltage between ABSCM&H/U connector and chassis ground.

Connector & terminal

(F49) No. 25 (+) — Chassis ground (-):

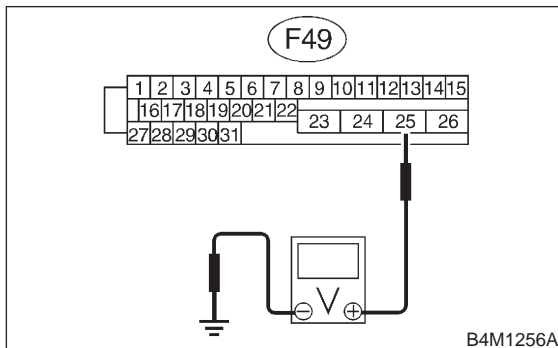

- CHECK** : Is the voltage between 10 V and 13 V?
- YES** : Go to step 10AE2.
- NO** : Repair harness/connector between battery and ABSCM&H/U and check fuse SBF-holder.

10AE2 : CHECK GROUND CIRCUIT OF MOTOR.

- 1) Turn ignition switch to OFF.
- 2) Measure resistance between ABSCM&H/U connector and chassis ground.

Connector & terminal

(F49) No. 26 — Chassis ground:

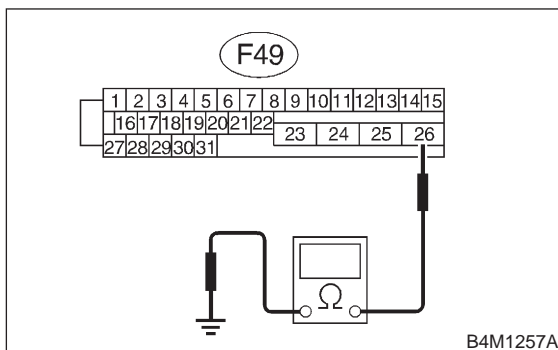

- CHECK** : Is the resistance less than 0.5 Ω?
- YES** : Go to step 10AE3.
- NO** : Repair ABSCM&H/U ground harness.

10AE3 : CHECK INPUT VOLTAGE OF ABSCM&H/U.

- 1) Run the engine at idle.
- 2) Measure voltage between ABSCM&H/U connector and chassis ground.

Connector & terminal

(F49) No. 1 (+) — Chassis ground (-):

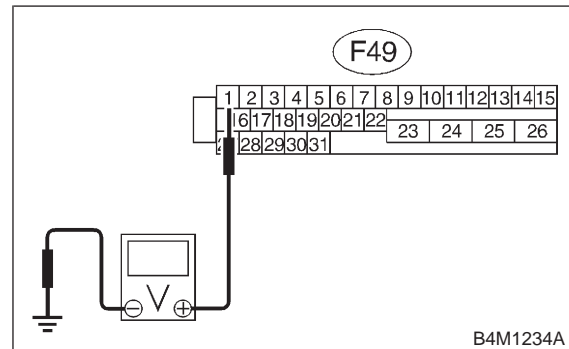

- CHECK** : Is the voltage between 10 V and 15 V?
- YES** : Go to step 10AE4.
- NO** : Repair harness connector between battery, ignition switch and ABSCM&H/U.

10AE4 : CHECK GROUND CIRCUIT OF ABSCM&H/U.

- 1) Turn ignition switch to OFF.
- 2) Measure resistance between ABSCM&H/U connector and chassis ground.

Connector & terminal

(F49) No. 23 — Chassis ground:

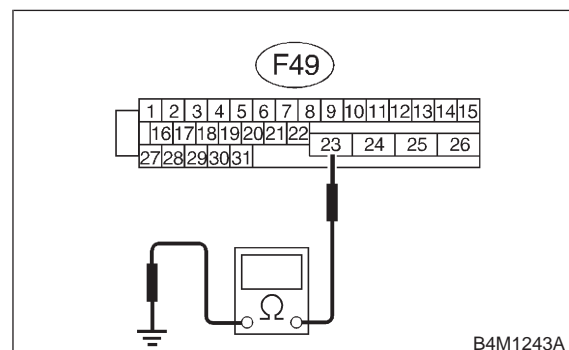

- CHECK** : Is the resistance less than 0.5 Ω?
- YES** : Go to step 10AE5.
- NO** : Repair ABSCM&H/U ground harness.

10AE5 : CHECK MOTOR OPERATION.

Operate the sequence control. <Ref. to 4-4 [W14D0].>

NOTE:

Use the diagnosis connector to operate the sequence control.

CHECK : ***Can motor revolution noise (buzz) be heard when carrying out the sequence control?***

YES : Go to step **10AE6**.

NO : Replace hydraulic unit.

10AE6 : CHECK POOR CONTACT IN CONNECTORS.

Turn ignition switch to OFF.

CHECK : ***Is there poor contact in connector between generator, battery and ABSCM&H/U? <Ref. to FOREWORD [T3C1].>***

YES : Repair connector.

NO : Go to step **10AE7**.

10AE7 : CHECK ABSCM&H/U.

- 1) Connect all connectors.
- 2) Erase the memory.
- 3) Perform inspection mode.
- 4) Read out the trouble code.

CHECK : ***Is the same trouble code as in the current diagnosis still being output?***

YES : Replace ABSCM&H/U.

NO : Go to step **10AE8**.

10AE8 : CHECK ANY OTHER TROUBLE CODES APPEARANCE.

CHECK : ***Are other trouble codes being output?***

YES : Proceed with the diagnosis corresponding to the trouble code.

NO : A temporary poor contact.

MEMO:

AF: TROUBLE CODE 54 STOP LIGHT SWITCH SIGNAL CIRCUIT MALFUNCTION

— STOP LIGHT SWITCH SIGNAL CIRCUIT MALFUNCTION —

DIAGNOSIS:

- Faulty stop light switch

TROUBLE SYMPTOM:

- ABS does not operate.

WIRING DIAGRAM:

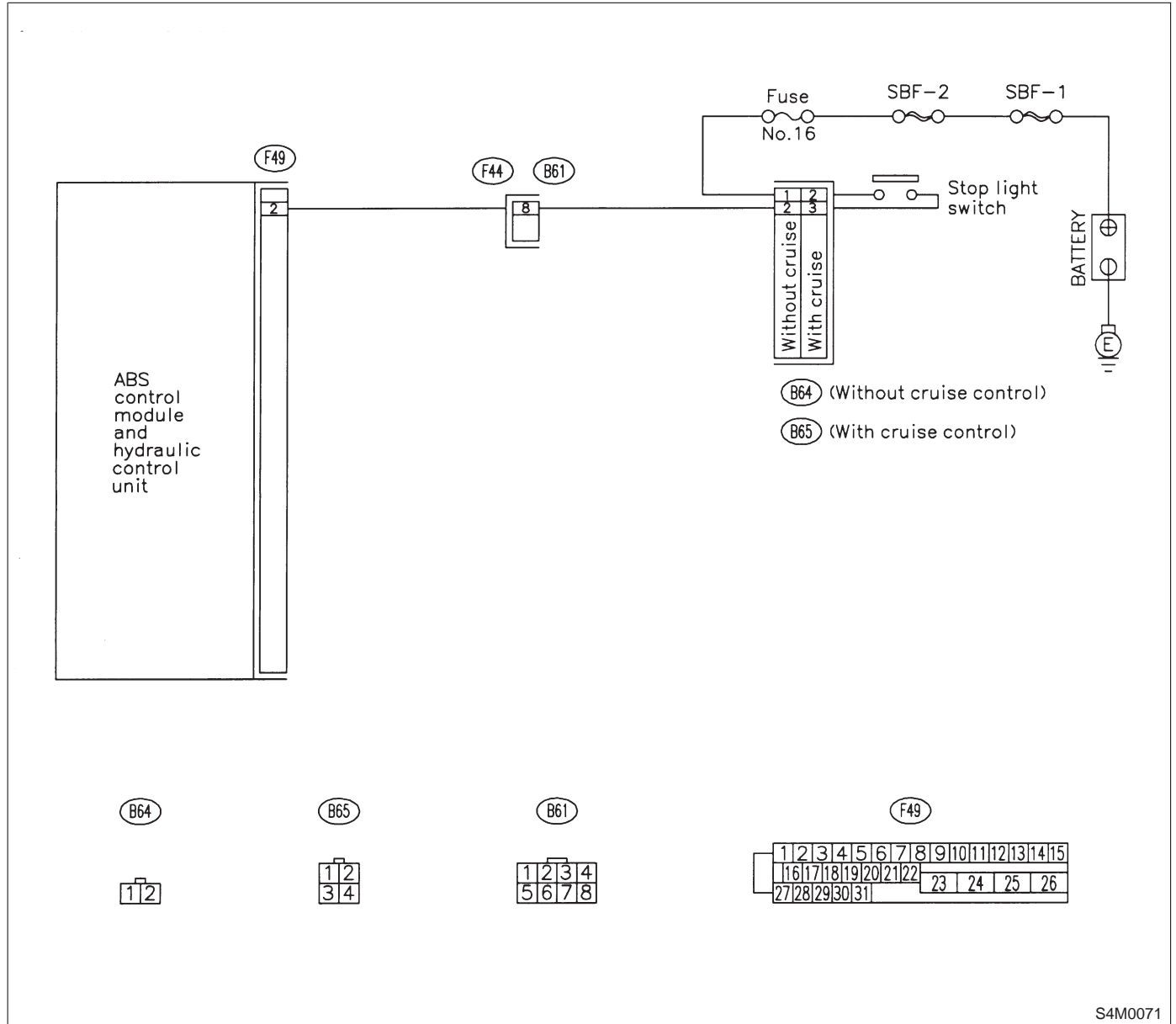

S4M0071

10AF1 : CHECK OUTPUT OF STOP LIGHT SWITCH USING SELECT MONITOR.

- 1) Select "Current data display & Save" on the select monitor.
- 2) Release the brake pedal.
- 3) Read the stop light switch output in the select monitor data display.

- CHECK** : *Is the reading indicated on monitor display less than 1.5 V?*
- YES** : Go to step 10AF2.
- NO** : Go to step 10AF3.

10AF2 : CHECK OUTPUT OF STOP LIGHT SWITCH USING SELECT MONITOR.

- 1) Depress the brake pedal.
- 2) Read the stop light switch output in the select monitor data display.

- CHECK** : *Is the reading indicated on monitor display between 10 V and 15 V?*
- YES** : Go to step 10AF5.
- NO** : Go to step 10AF3.

10AF3 : CHECK IF STOP LIGHTS COME ON.

Depress the brake pedal.

- CHECK** : *Do stop lights turn on?*
- YES** : Go to step 10AF4.
- NO** : Repair stop lights circuit.

10AF4 : CHECK OPEN CIRCUIT IN HARNESS.

- 1) Turn ignition switch to OFF.
- 2) Disconnect connector from ABSCM&H/U.
- 3) Depress brake pedal.
- 4) Measure voltage between ABSCM&H/U connector and chassis ground.

Connector & terminal

(F49) No. 2 — Chassis ground:

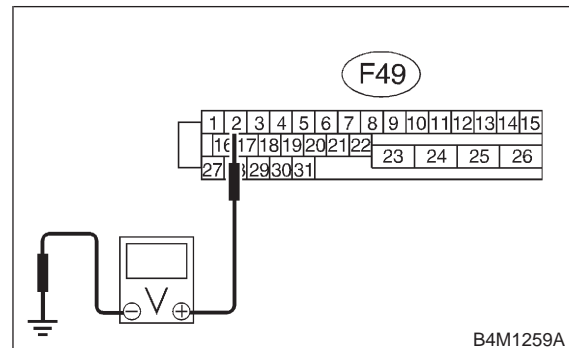

- CHECK** : *Is the voltage between 10 V and 15 V?*
- YES** : Go to step 10AF5.
- NO** : Repair harness between stop light switch and ABSCM&H/U connector.

10AF5 : CHECK POOR CONTACT IN CONNECTORS.

- CHECK** : *Is there poor contact in connector between stop light switch and ABSCM&H/U? <Ref. to FOREWORD [T3C1].>*
- YES** : Repair connector.
- NO** : Go to step 10AF6.

10AF6 : CHECK ABSCM&H/U.

- 1) Connect all connectors.
- 2) Erase the memory.
- 3) Perform inspection mode.
- 4) Read out the trouble code.

- CHECK** : *Is the same trouble code as in the current diagnosis still being output?*
- YES** : Replace ABSCM&H/U.
- NO** : Go to step 10AF7.

10AF7 : CHECK ANY OTHER TROUBLE CODES APPEARANCE.

- CHECK** : *Are other trouble codes being output?*
- YES** : Proceed with the diagnosis corresponding to the trouble code.
- NO** : A temporary poor contact.

MEMO:

AG: TROUBLE CODE 56 OPEN OR SHORT CIRCUIT IN G SENSOR CIRCUIT — OPEN OR SHORT CIRCUIT IN G SENSOR CIRCUIT —

DIAGNOSIS:

- Faulty G sensor output voltage

TROUBLE SYMPTOM:

- ABS does not operate.

WIRING DIAGRAM:

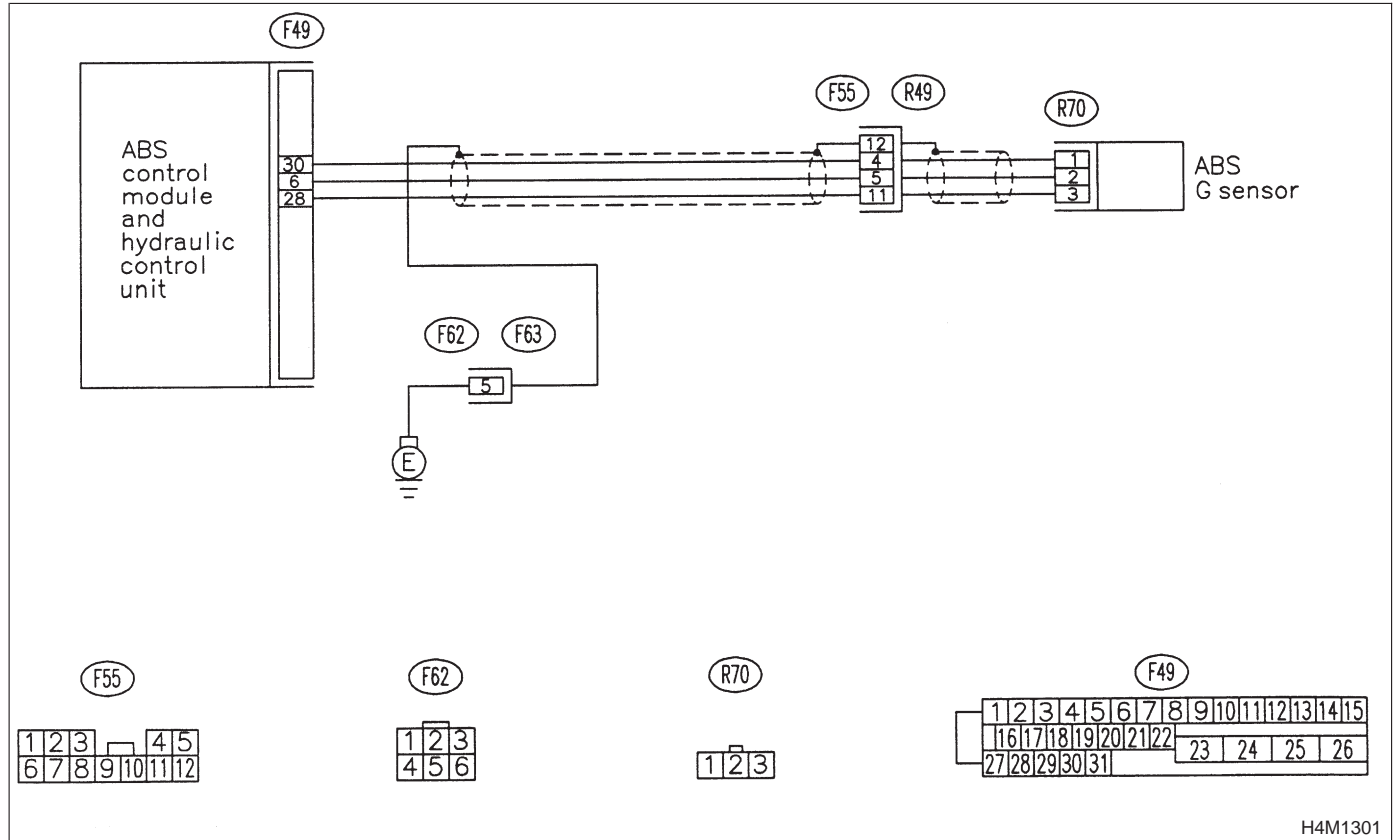

H4M1301

10AG1 : CHECK SPECIFICATIONS OF ABSCM&H/U.

Check specifications of the mark to the ABSCM&H/U.

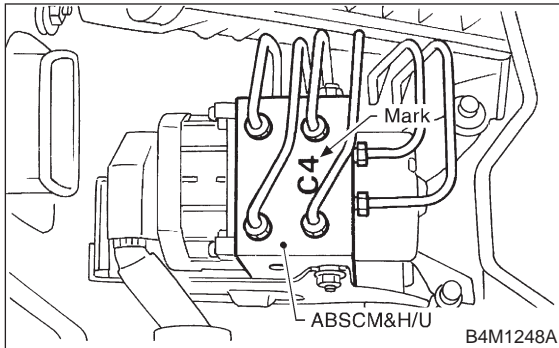

Mark	Model
C5	AWD AT
C6	AWD MT

CHECK : *Is an ABSCM for AWD model installed on a FWD model?*

YES : Replace ABSCM&H/U.

CAUTION:

Be sure to turn ignition switch to OFF when removing ABSCM&H/U.

NO : Go to step 10AG2.

10AG2 : CHECK OUTPUT OF G SENSOR USING SELECT MONITOR.

- 1) Select "Current data display & Save" on the select monitor.
- 2) Read the G sensor output in select monitor data display.

CHECK : *Is the G sensor output on the monitor display between 2.1 and 2.5 V when the G sensor is in horizontal position?*

YES : Go to step 10AG3.

NO : Go to step 10AG6.

10AG3 : CHECK POOR CONTACT IN CONNECTORS.

CHECK : *Is there poor contact in connector between ABSCM&H/U and G sensor? <Ref. to FOREWORD [T3C1].>*

YES : Repair connector.

NO : Go to step 10AG4.

10AG4 : CHECK ABSCM&H/U.

- 1) Connect all connectors.
- 2) Erase the memory.
- 3) Perform inspection mode.
- 4) Read out the trouble code.

CHECK : *Is the same trouble code as in the current diagnosis still being output?*

YES : Replace ABSCM&H/U.

NO : Go to step 10AG5.

10AG5 : CHECK ANY OTHER TROUBLE CODES APPEARANCE.

CHECK : *Are other trouble codes being output?*

YES : Proceed with the diagnosis corresponding to the trouble code.

NO : A temporary poor contact.

10AG6 : CHECK FREEZE FRAME DATA.

- 1) Select "Freeze frame data" on the select monitor.
- 2) Read front right wheel speed on the select monitor display.

CHECK : *Is the front right wheel speed on monitor display 0 km?*

YES : Go to step 10AG7.

NO : Go to step 10AG15.

10AG7 : CHECK FREEZE FRAME DATA.

Read front left wheel speed on the select monitor display.

CHECK : *Is the front left wheel speed on monitor display 0 km?*

YES : Go to step 10AG8.

NO : Go to step 10AG15.

10AG8 : CHECK FREEZE FRAME DATA.

Read rear right wheel speed on the select monitor display.

CHECK : *Is the rear right wheel speed on monitor display 0 km?*

YES : Go to step 10AG9.

NO : Go to step 10AG15.

10AG9 : CHECK FREEZE FRAME DATA.

Read rear left wheel speed on the select monitor display.

CHECK : *Is the rear left wheel speed on monitor display 0 km?*

YES : Go to step **10AG10**.

NO : Go to step **10AG15**.

10AG10 : CHECK FREEZE FRAME DATA.

Read G sensor output on the select monitor display.

CHECK : *Is the G sensor output on monitor display more than 3.65 V?*

YES : Go to step **10AG11**.

NO : Go to step **10AG15**.

10AG11 : CHECK OPEN CIRCUIT IN G SENSOR OUTPUT HARNESS AND GROUND HARNESS.

- 1) Turn ignition switch to OFF.
- 2) Disconnect connector from ABSCM&H/U.
- 3) Measure resistance between ABSCM&H/U connector terminals.

Connector & terminal

(F49) No. 30 — No. 28:

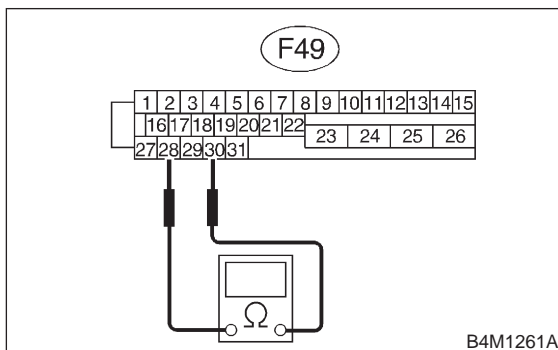

CHECK : *Is the resistance between 4.3 and 4.9 kΩ?*

YES : Go to step **10AG12**.

NO : Repair harness/connector between G sensor and ABSCM&H/U.

10AG12 : CHECK POOR CONTACT IN CONNECTORS.

CHECK : *Is there poor contact in connector between ABSCM&H/U and G sensor? <Ref. to FOREWORD [T3C1].>*

YES : Repair connector.

NO : Go to step **10AG13**.

10AG13 : CHECK ABSCM&H/U.

- 1) Connect all connectors.
- 2) Erase the memory.
- 3) Perform inspection mode.
- 4) Read out the trouble code.

CHECK : *Is the same trouble code as in the current diagnosis still being output?*

YES : Replace ABSCM&H/U.

NO : Go to step **10AG14**.

10AG14 : CHECK ANY OTHER TROUBLE CODES APPEARANCE.

CHECK : *Are other trouble codes being output?*

YES : Proceed with the diagnosis corresponding to the trouble code.

NO : A temporary poor contact.

10AG15 : CHECK INPUT VOLTAGE OF G SENSOR.

- 1) Turn ignition switch to OFF.
- 2) Remove console box.
- 3) Disconnect G sensor from body. (Do not disconnect connector.)
- 4) Turn ignition switch to ON.
- 5) Measure voltage between G sensor connector terminals.

Connector & terminal
(R70) No. 1 (+) — No. 3 (-):

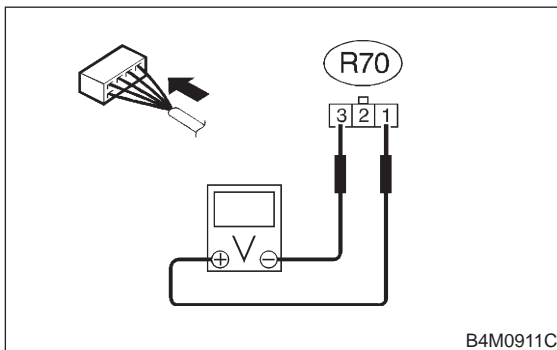

- CHECK** : **Is the voltage between 4.75 and 5.25 V?**
- YES** : Go to step **10AG16**.
- NO** : Repair harness/connector between G sensor and ABSCM&H/U.

10AG16 : CHECK OPEN CIRCUIT IN G SENSOR OUTPUT HARNESS AND GROUND HARNESS.

- 1) Turn ignition switch to OFF.
- 2) Disconnect connector from ABSCM&H/U.
- 3) Measure resistance between ABSCM&H/U connector terminals.

Connector & terminal
(F49) No. 30 — No. 28:

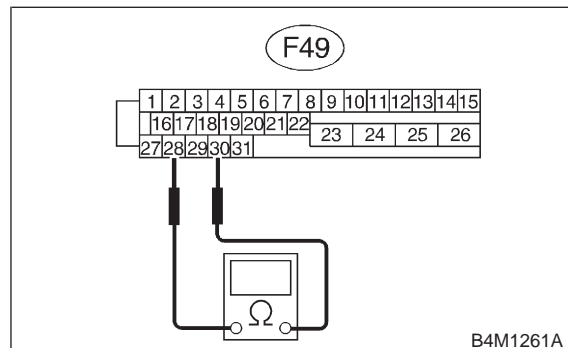

- CHECK** : **Is the resistance between 4.3 and 4.9 kΩ?**
- YES** : Go to step **10AG17**.
- NO** : Repair harness/connector between G sensor and ABSCM&H/U.

10AG17 : CHECK GROUND SHORT IN G SENSOR OUTPUT HARNESS.

- 1) Disconnect connector from G sensor.
- 2) Measure resistance between ABSCM&H/U connector and chassis ground.

Connector & terminal
(F49) No. 6 — Chassis ground:

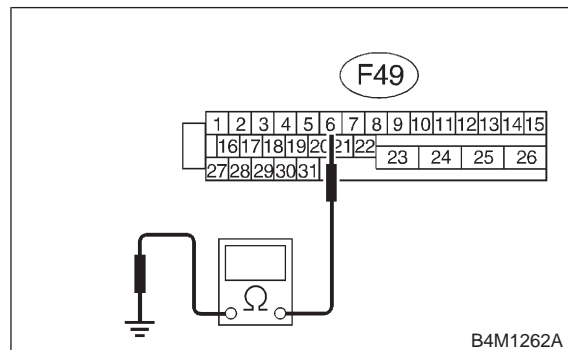

- CHECK** : **Is the resistance more than 1 MΩ?**
- YES** : Go to step **10AG18**.
- NO** : Repair harness between G sensor and ABSCM&H/U.

10AG18 : CHECK G SENSOR.

- 1) Connect connector to G sensor.
- 2) Connect connector to ABSCM&H/U.
- 3) Turn ignition switch to ON.
- 4) Measure voltage between G sensor connector terminals.

Connector & terminal

(R70) No. 2 (+) — No. 3 (-):

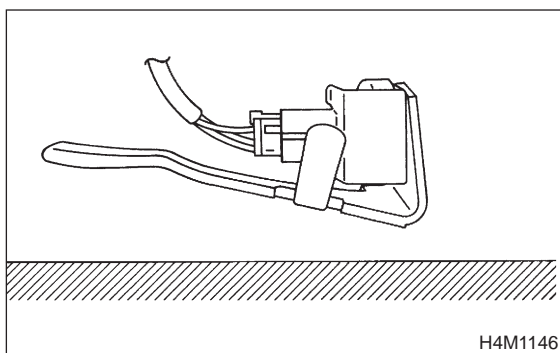
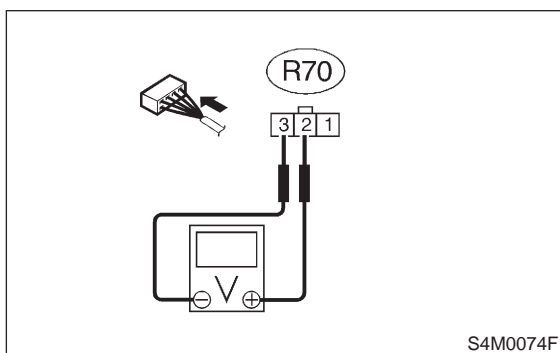

CHECK : *Is the voltage between 2.1 and 2.5 V when G sensor is horizontal?*

YES : Go to step **10AG19**.

NO : Replace G sensor.

10AG19 : CHECK G SENSOR.

Measure voltage between G sensor connector terminals.

Connector & terminal

(R70) No. 2 (+) — No. 3 (-):

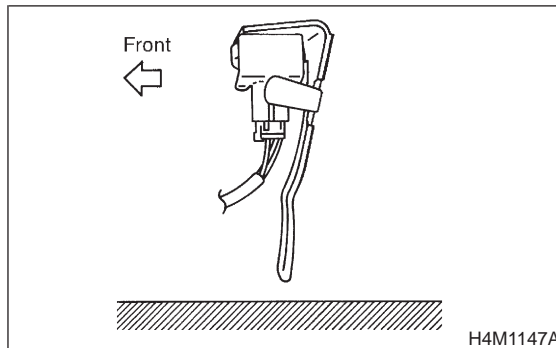

CHECK : *Is the voltage between 3.7 and 4.1 V when G sensor is inclined forwards to 90°?*

YES : Go to step **10AG20**.

NO : Replace G sensor.

10AG20 : CHECK G SENSOR.

Measure voltage between G sensor connector terminals.

Connector & terminal

(R70) No. 2 (+) — No. 3 (-):

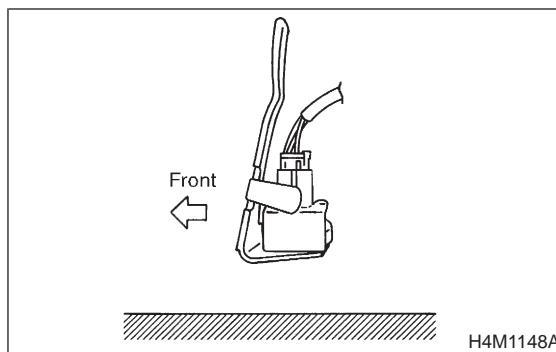

CHECK : *Is the voltage between 0.5 and 0.9 V when G sensor is inclined backwards to 90°?*

YES : Go to step **10AG21**.

NO : Replace G sensor.

10AG21 : CHECK POOR CONTACT IN CONNECTORS.

Turn ignition switch to OFF.

CHECK : *Is there poor contact in connector between ABSCM&H/U and G sensor? <Ref. to FOREWORD [T3C1].>*

YES : Repair connector.

NO : Go to step **10AG22**.

10AG22 : CHECK ABSCM&H/U.

- 1) Connect all connectors.
- 2) Erase the memory.
- 3) Perform inspection mode.
- 4) Read out the trouble code.

CHECK : *Is the same trouble code as in the current diagnosis still being output?*

YES : Replace ABSCM&H/U.

NO : Go to step **10AG23**.

10AG23 : CHECK ANY OTHER TROUBLE CODES APPEARANCE.

CHECK : *Are other trouble codes being output?*

YES : Proceed with the diagnosis corresponding to the trouble code.

NO : A temporary poor contact.

**AH: TROUBLE CODE 56 BATTERY SHORT IN G SENSOR CIRCUIT
— BATTERY SHORT IN G SENSOR CIRCUIT —**

DIAGNOSIS:

- Faulty G sensor output voltage

TROUBLE SYMPTOM:

- ABS does not operate.

WIRING DIAGRAM:

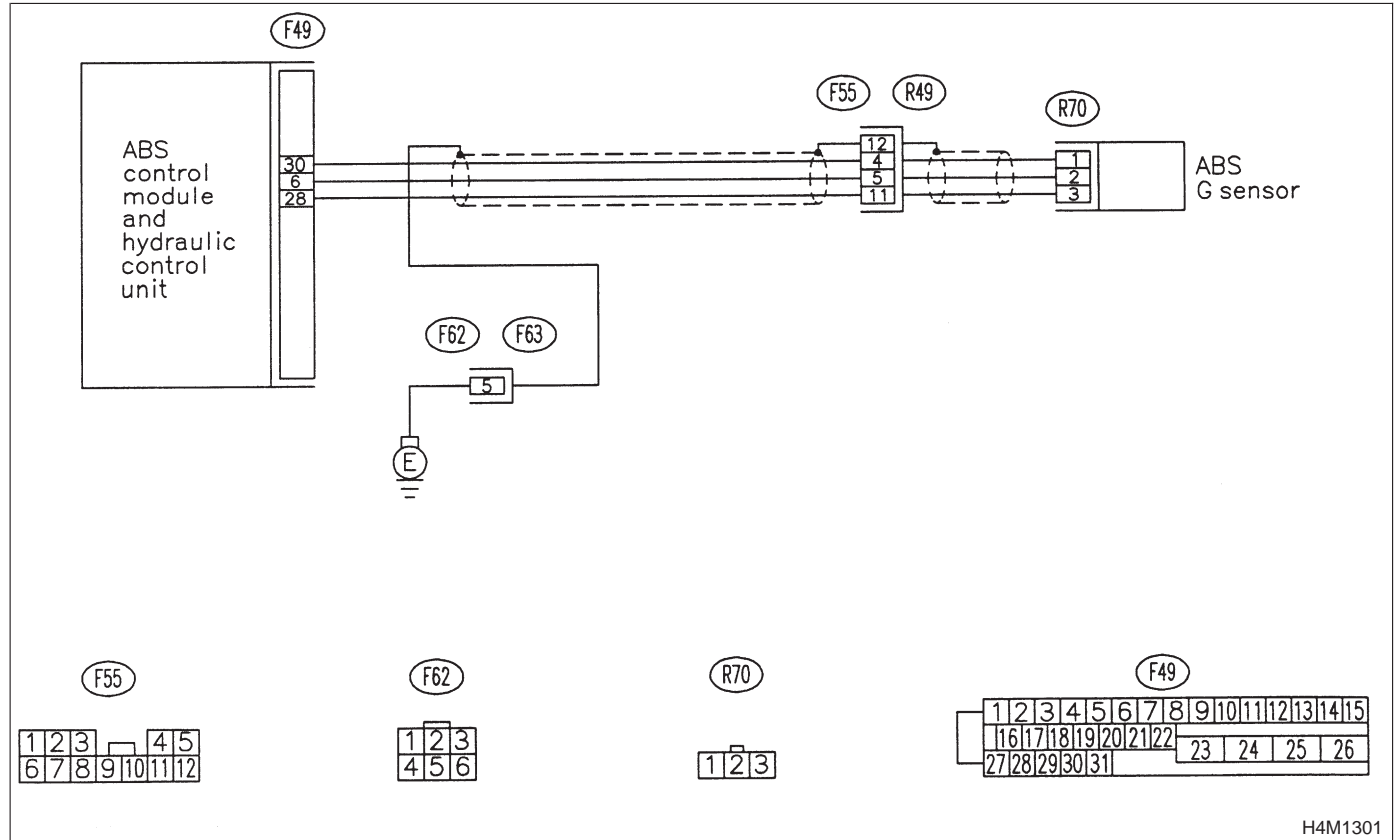

H4M1301

10AH1 : CHECK OUTPUT OF G SENSOR USING SELECT MONITOR.

- 1) Select "Current data display & Save" on the select monitor.
- 2) Read G sensor output on the select monitor display.

CHECK : *Is the G sensor output on monitor display between 2.1 and 2.5 V when the G sensor is in horizontal position?*

YES : Replace ABSCM&H/U.

NO : Go to step **10AH2**.

10AH2 : CHECK BATTERY SHORT OF HARNESS.

- 1) Turn ignition switch to OFF.
- 2) Remove console box.
- 3) Disconnect connector from G sensor.
- 4) Disconnect connector from ABSCM&H/U.
- 5) Measure voltage between ABSCM&H/U connector and chassis ground.

Connector & terminal

(F49) No. 6 (+) — Chassis ground (-):

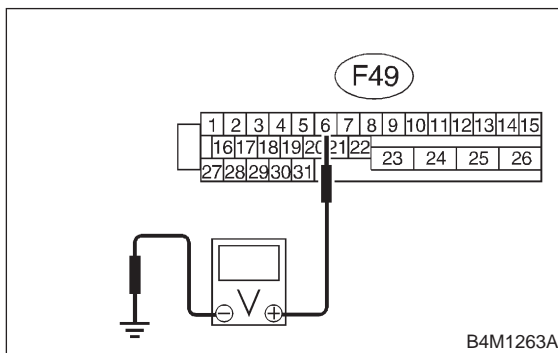

CHECK : *Is the voltage less than 1 V?*

YES : Go to step **10AH3**.

NO : Repair harness between G sensor and ABSCM&H/U.

10AH3 : CHECK BATTERY SHORT OF HARNESS.

- 1) Turn ignition switch to ON.
- 2) Measure voltage between ABSCM&H/U connector and chassis ground.

Connector & terminal

(F49) No. 6 (+) — Chassis ground (-):

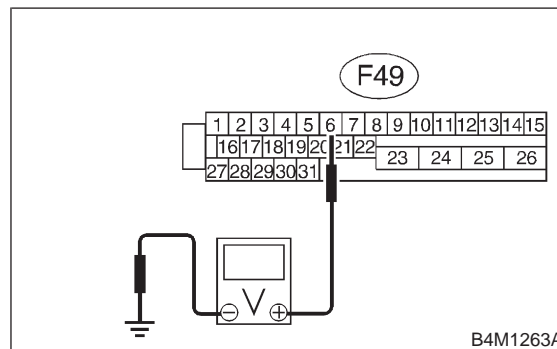

CHECK : *Is the voltage less than 1 V?*

YES : Go to step **10AH4**.

NO : Repair harness between G sensor and ABSCM&H/U.

10AH4 : CHECK ABSCM&H/U.

- 1) Turn ignition switch to OFF.
- 2) Connect all connectors.
- 3) Erase the memory.
- 4) Perform inspection mode.
- 5) Read out the trouble code.

CHECK : *Is the same trouble code as in the current diagnosis still being output?*

YES : Replace ABSCM&H/U.

NO : Go to step **10AH5**.

10AH5 : CHECK ANY OTHER TROUBLE CODES APPEARANCE.

CHECK : *Are other trouble codes being output?*

YES : Proceed with the diagnosis corresponding to the trouble code.

NO : A temporary poor contact.

AI: TROUBLE CODE 56 ABNORMAL G SENSOR HIGH μ OUTPUT
— ABNORMAL G SENSOR HIGH μ OUTPUT —

DIAGNOSIS:

- Faulty G sensor output voltage

TROUBLE SYMPTOM:

- ABS does not operate.

WIRING DIAGRAM:

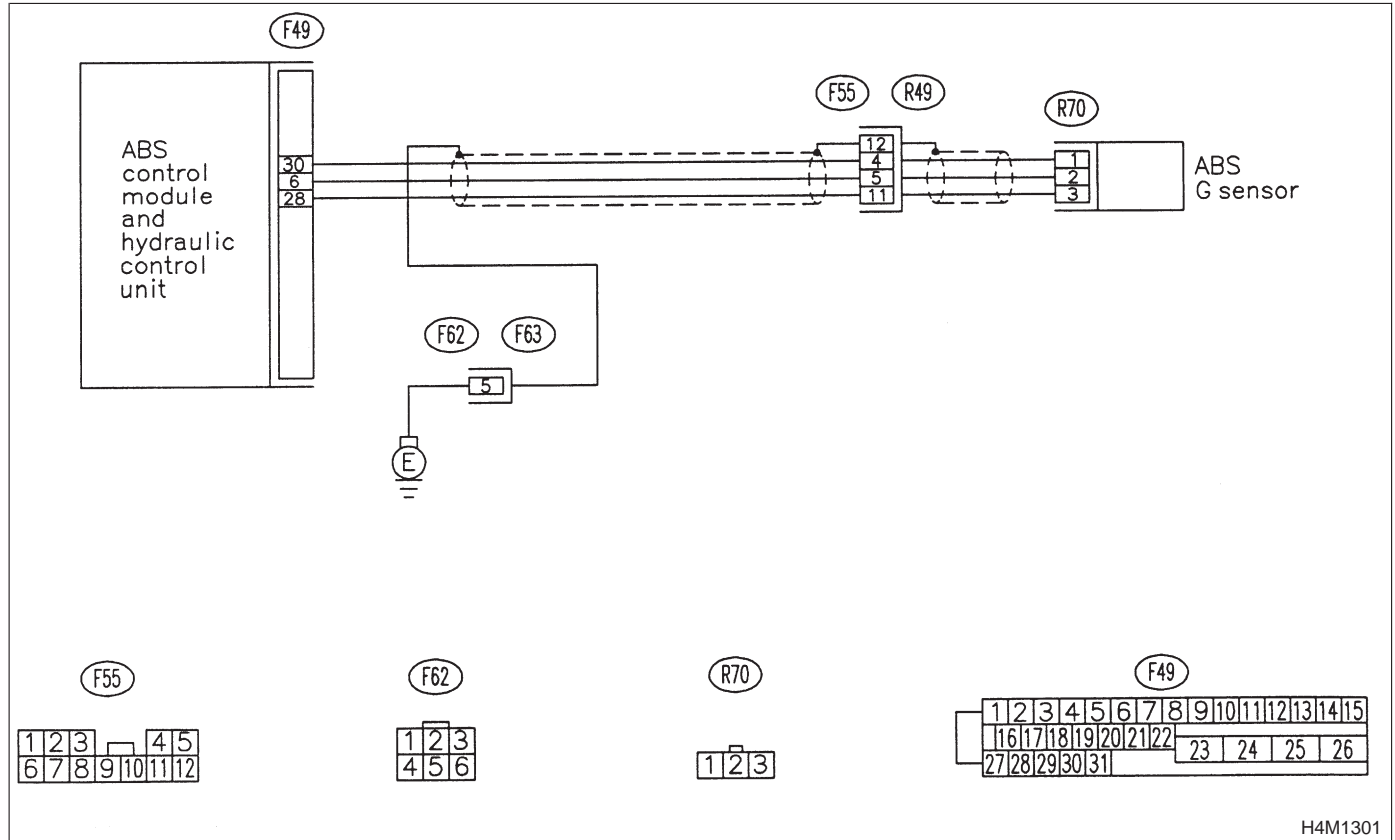

H4M1301

10A11 : CHECK OUTPUT OF G SENSOR USING SELECT MONITOR.

- 1) Select "Current data display & Save" on the select monitor.
- 2) Read G sensor output on the select monitor display.

CHECK : *Is the G sensor output on monitor display 2.3 ± 0.2 V when the G sensor is in horizontal position?*

YES : Go to step 10A12.

NO : Go to step 10A16.

10A12 : CHECK POOR CONTACT IN CONNECTORS.

Turn ignition switch to OFF.

CHECK : *Is there poor contact in connector between ABSCM&H/U and G sensor? <Ref. to FOREWORD [T3C1].>*

YES : Repair connector.

NO : Go to step 10A13.

10A13 : CHECK ABSCM&H/U.

- 1) Connect all connectors.
- 2) Erase the memory.
- 3) Perform inspection mode.
- 4) Read out the trouble code.

CHECK : *Is the same trouble code as in the current diagnosis still being output?*

YES : Replace ABSCM&H/U.

NO : Go to step 10A14.

10A14 : CHECK ANY OTHER TROUBLE CODES APPEARANCE.

CHECK : *Are other trouble codes being output?*

YES : Proceed with the diagnosis corresponding to the trouble code.

NO : A temporary poor contact.

10A15 : CHECK OPEN CIRCUIT IN G SENSOR OUTPUT HARNESS AND GROUND HARNESS.

- 1) Turn ignition switch to OFF.
- 2) Disconnect connector from ABSCM&H/U.
- 3) Measure resistance between ABSCM&H/U connector terminals.

Connector & terminal
(F49) No. 30 — No. 28:

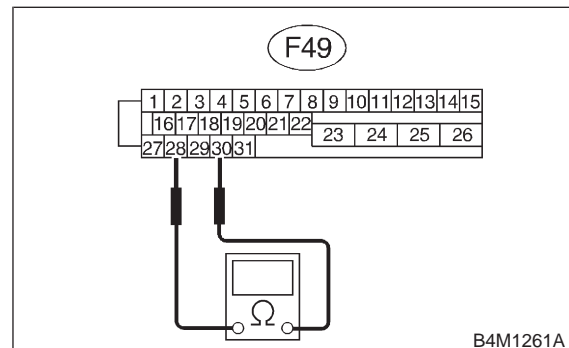

CHECK : *Is the resistance between 4.3 and 4.9 kΩ?*

YES : Go to step 10A16.

NO : Repair harness/connector between G sensor and ABSCM&H/U.

10A16 : CHECK GROUND SHORT OF HARNESS.

Measure resistance between ABSCM&H/U connector and chassis ground.

Connector & terminal
(F49) No. 28 — Chassis ground:

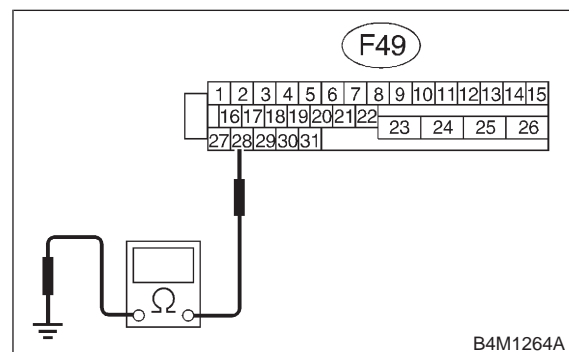

CHECK : *Is the resistance more than 1 MΩ?*

YES : Go to step 10A17.

NO : Repair harness between G sensor and ABSCM&H/U.
Replace ABSCM&H/U.

10AI7 : CHECK G SENSOR.

- 1) Remove console box.
- 2) Remove G sensor from vehicle.
- 3) Connect connector to G sensor.
- 4) Connect connector to ABSCM&H/U.
- 5) Turn ignition switch to ON.
- 6) Measure voltage between G sensor connector terminals.

Connector & terminal

(R70) No. 2 (+) — No. 3 (-):

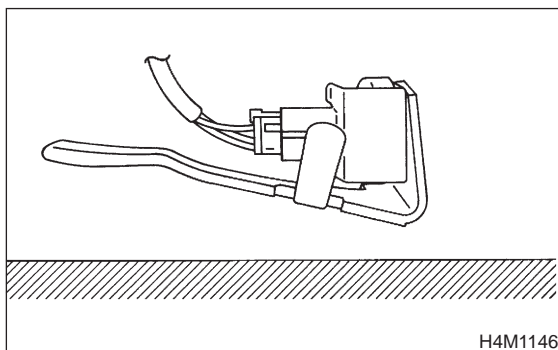
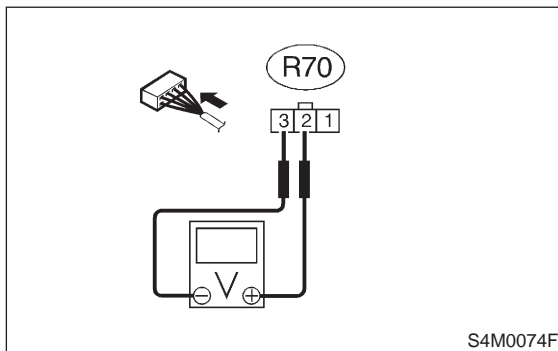

CHECK : *Is the voltage between 2.1 and 2.5 V when G sensor is horizontal?*

YES : Go to step 10AI8.

NO : Replace G sensor.

10AI8 : CHECK G SENSOR.

Measure voltage between G sensor connector terminals.

Connector & terminal

(R70) No. 2 (+) — No. 3 (-):

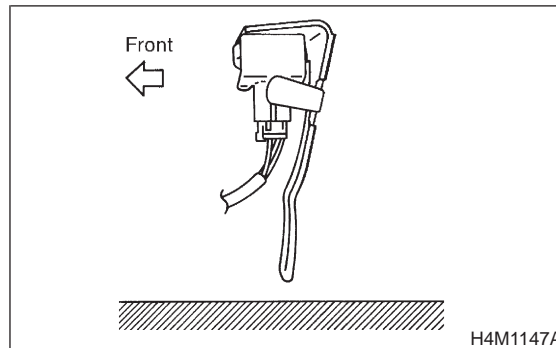

CHECK : *Is the voltage between 3.7 and 4.1 V when G sensor is inclined forwards to 90°?*

YES : Go to step 10AI9.

NO : Replace G sensor.

10AI9 : CHECK G SENSOR.

Measure voltage between G sensor connector terminals.

Connector & terminal

(R70) No. 2 (+) — No. 3 (-):

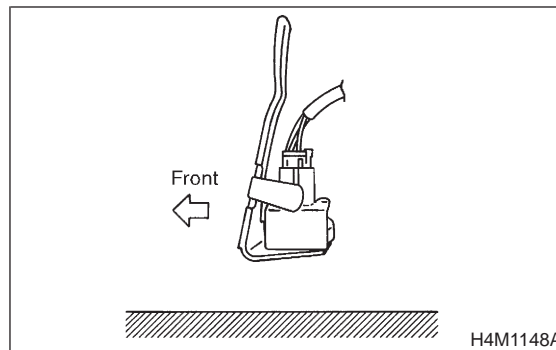

CHECK : *Is the voltage between 0.5 and 0.9 V when G sensor is inclined backwards to 90°?*

YES : Go to step 10AI10.

NO : Replace G sensor.

10AI10 : CHECK ABSCM&H/U.

- 1) Turn ignition switch to OFF.
- 2) Connect all connectors.
- 3) Erase the memory.
- 4) Perform inspection mode.
- 5) Read out the trouble code.

CHECK : *Is the same trouble code as in the current diagnosis still being output?*

YES : Replace ABSCM&H/U.

NO : Go to step **10AI11**.

10AI11 : CHECK ANY OTHER TROUBLE CODES APPEARANCE.

CHECK : *Are other trouble codes being output?*

YES : Proceed with the diagnosis corresponding to the trouble code.

NO : A temporary poor contact.

**AJ: TROUBLE CODE 56 DETECTION OF G SENSOR STICK
— DETECTION OF G SENSOR STICK —**

DIAGNOSIS:

- Faulty G sensor output voltage

TROUBLE SYMPTOM:

- ABS does not operate.

WIRING DIAGRAM:

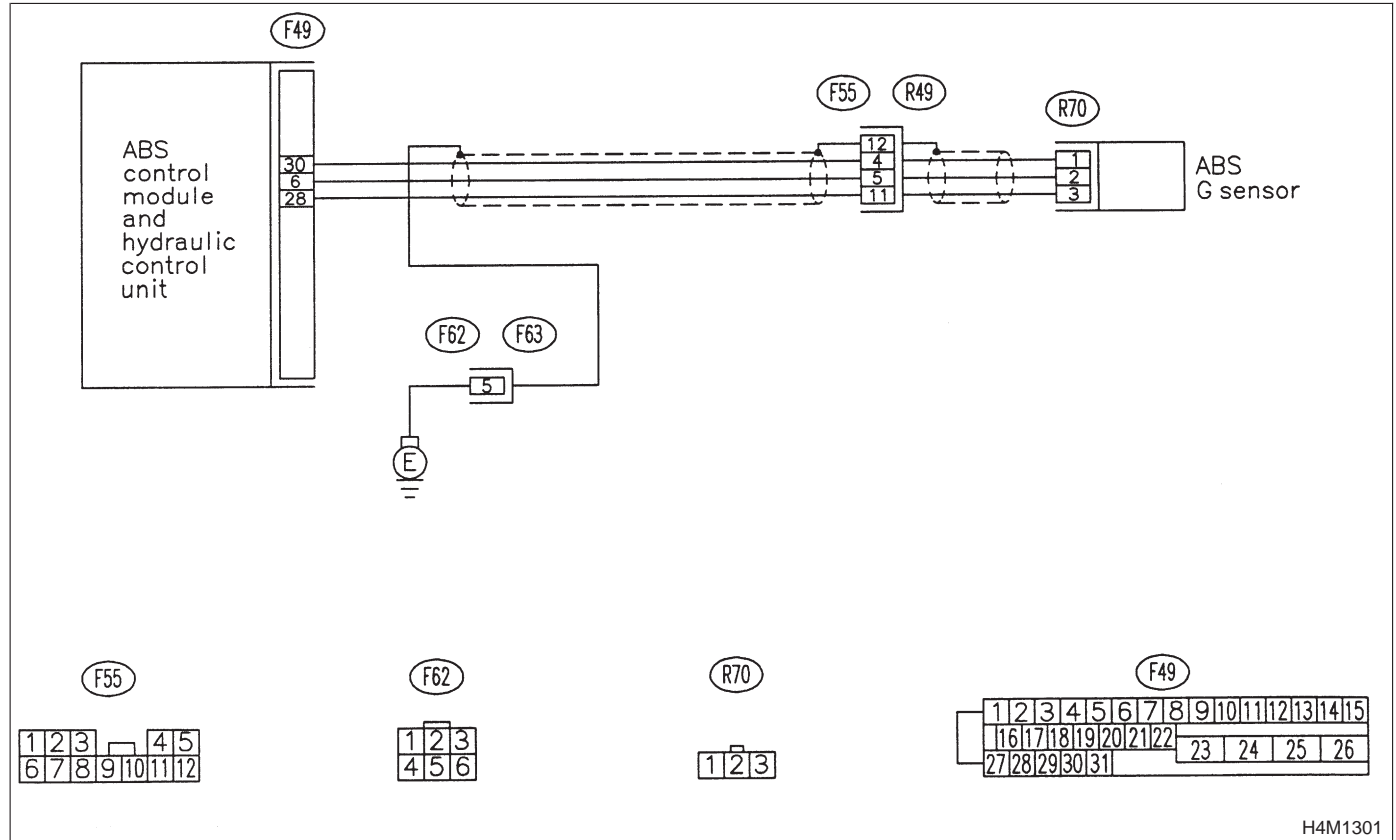

H4M1301

10AJ1 : CHECK ALL FOUR WHEELS FOR FREE TURNING.

- CHECK** : *Have the wheels been turned freely such as when the vehicle is lifted up, or operated on a rolling road?*
- YES** : The ABS is normal. Erase the trouble code.
- NO** : Go to step 10AJ2.

10AJ2 : CHECK OUTPUT OF G SENSOR USING SELECT MONITOR.

- 1) Select "Current data display & Save" on the select monitor.
- 2) Read the select monitor display.

- CHECK** : *Is the G sensor output on the monitor display between 2.1 and 2.5 V when the vehicle is in horizontal position?*
- YES** : Go to step 10AJ3.
- NO** : Go to step 10AJ8.

10AJ3 : CHECK OUTPUT OF G SENSOR USING SELECT MONITOR.

- 1) Turn ignition switch to OFF.
- 2) Remove console box.
- 3) Remove G sensor from vehicle. (Do not disconnect connector.)
- 4) Turn ignition switch to ON.
- 5) Select "Current data display & Save" on the select monitor.
- 6) Read the select monitor display.

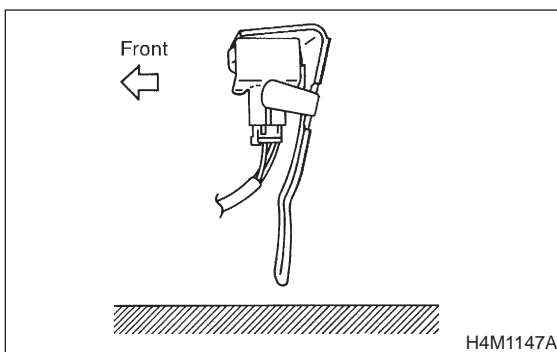

- CHECK** : *Is the G sensor output on the monitor display between 3.7 and 4.1 V when G sensor is inclined forwards to 90°?*
- YES** : Go to step 10AJ4.
- NO** : Replace G sensor.

10AJ4 : CHECK OUTPUT OF G SENSOR USING SELECT MONITOR.

Read the select monitor display.

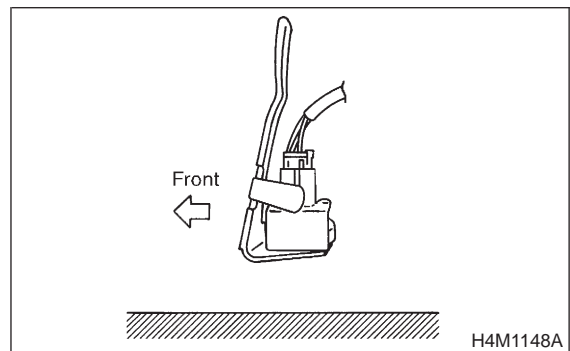

- CHECK** : *Is the G sensor output on the monitor display between 0.5 and 0.9 V when G sensor is inclined backwards to 90°?*
- YES** : Go to step 10AJ5.
- NO** : Replace G sensor.

10AJ5 : CHECK POOR CONTACT IN CONNECTORS.

Turn ignition switch to OFF.

- CHECK** : *Is there poor contact in connector between ABSCM&H/U and G sensor? <Ref. to FOREWORD [T3C1].>*
- YES** : Repair connector.
- NO** : Go to step 10AJ6.

10AJ6 : CHECK ABSCM&H/U.

- 1) Connect all connectors.
- 2) Erase the memory.
- 3) Perform inspection mode.
- 4) Read out the trouble code.

- CHECK** : *Is the same trouble code as in the current diagnosis still being output?*
- YES** : Replace ABSCM&H/U.
- NO** : Go to step 10AJ7.

10AJ7 : CHECK ANY OTHER TROUBLE CODES APPEARANCE.

- CHECK** : *Are other trouble codes being output?*
- YES** : Proceed with the diagnosis corresponding to the trouble code.
- NO** : A temporary poor contact.

10AJ8 : CHECK OPEN CIRCUIT IN G SENSOR OUTPUT HARNESS AND GROUND HARNESS.

- 1) Turn ignition switch to OFF.
- 2) Disconnect connector from ABSCM&H/U.
- 3) Measure resistance between ABSCM&H/U connector terminals.

Connector & terminal

(F49) No. 30 — No. 28:

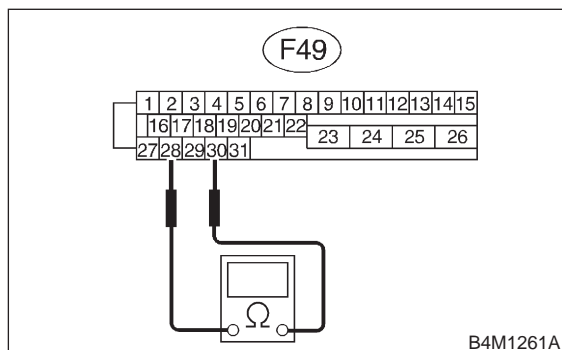

CHECK : *Is the resistance between 4.3 and 4.9 kΩ?*

YES : Go to step **10AJ9**.

NO : Repair harness/connector between G sensor and ABSCM&H/U.

10AJ9 : CHECK G SENSOR.

- 1) Remove console box.
- 2) Remove G sensor from vehicle.
- 3) Connect connector to G sensor.
- 4) Connect connector to ABSCM&H/U.
- 5) Turn ignition switch to ON.
- 6) Measure voltage between G sensor connector terminals.

Connector & terminal

(R70) No. 2 (+) — No. 1 (-):

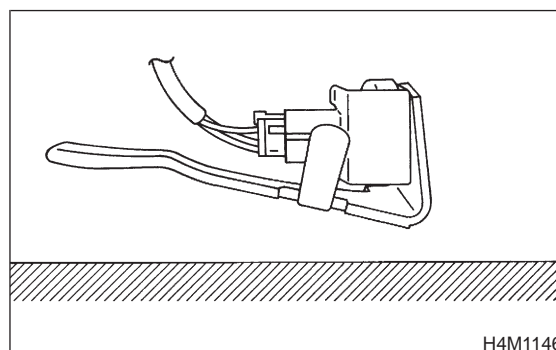
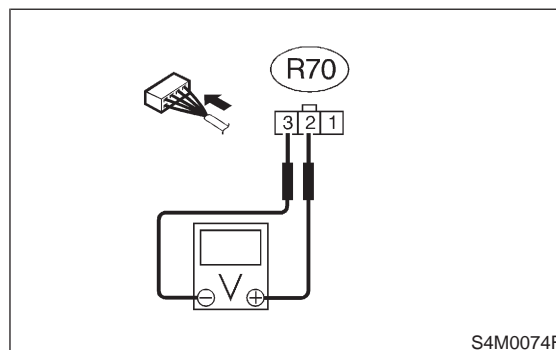

CHECK : *Is the voltage between 2.1 and 2.5 V when G sensor is horizontal?*

YES : Go to step **10AJ10**.

NO : Replace G sensor.

10AJ10 : CHECK G SENSOR.

Measure voltage between G sensor connector terminals.

Connector & terminal

(R70) No. 2 (+) — No. 1 (-):

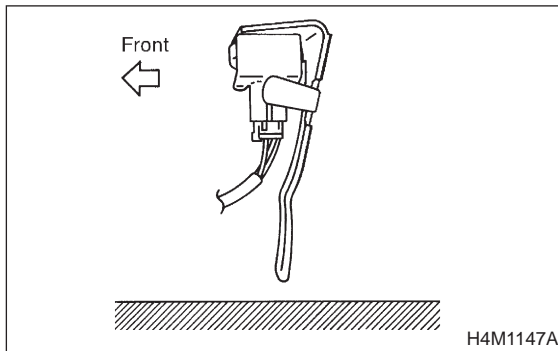

CHECK : *Is the voltage between 3.7 and 4.1 V when G sensor is inclined forwards to 90°?*

YES : Go to step 10AJ11.

NO : Replace G sensor.

10AJ11 : CHECK G SENSOR.

Measure voltage between G sensor connector terminals.

Connector & terminal

(R70) No. 2 (+) — No. 1 (-):

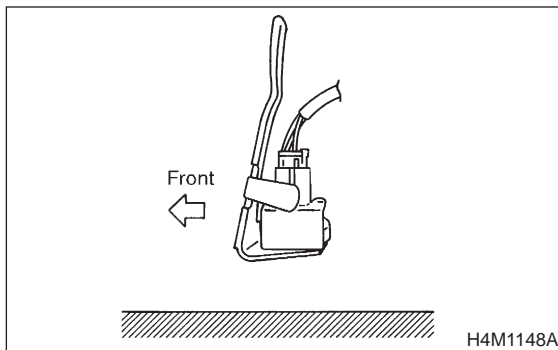

CHECK : *Is the voltage between 0.5 and 0.9 V when G sensor is inclined backwards to 90°?*

YES : Go to step 10AJ12.

NO : Replace G sensor.

10AJ12 : CHECK ABSCM&H/U.

- 1) Turn ignition switch to OFF.
- 2) Connect all connectors.
- 3) Erase the memory.
- 4) Perform inspection mode.
- 5) Read out the trouble code.

CHECK : *Is the same trouble code as in the current diagnosis still being output?*

YES : Replace ABSCM&H/U.

NO : Go to step 10AJ13.

10AJ13 : CHECK ANY OTHER TROUBLE CODES APPEARANCE.

CHECK : *Are other trouble codes being output?*

YES : Proceed with the diagnosis corresponding to the trouble code.

NO : A temporary poor contact.

11. General Diagnostic Table

A: SYMPTOMS AND PROBABLE CAUSES

Symptom		Probable faulty units/parts
Vehicle instability during braking	Vehicle pulls to either side.	<ul style="list-style-type: none"> ● ABSCM&H/U (solenoid valve) ● ABS sensor ● Brake (caliper & piston, pads) ● Wheel alignment ● Tire specifications, tire wear and air pressures ● Incorrect wiring or piping connections ● Road surface (uneven, camber)
	Vehicle spins.	<ul style="list-style-type: none"> ● ABSCM&H/U (solenoid valve) ● ABS sensor ● Brake (pads) ● Tire specifications, tire wear and air pressures ● Incorrect wiring or piping connections
Poor braking	Long braking/stopping distance	<ul style="list-style-type: none"> ● ABSCM&H/U (solenoid valve) ● Brake (pads) ● Air in brake line ● Tire specifications, tire wear and air pressures ● Incorrect wiring or piping connections
	Wheel locks.	<ul style="list-style-type: none"> ● ABSCM&H/U (solenoid valve, motor) ● ABS sensor ● Incorrect wiring or piping connections
	Brake dragging	<ul style="list-style-type: none"> ● ABSCM&H/U (solenoid valve) ● ABS sensor ● Master cylinder ● Brake (caliper & piston) ● Parking brake ● Axle & wheels ● Brake pedal play
	Long brake pedal stroke	<ul style="list-style-type: none"> ● Air in brake line ● Brake pedal play
	Vehicle pitching	<ul style="list-style-type: none"> ● Suspension play or fatigue (reduced damping) ● Incorrect wiring or piping connections ● Road surface (uneven)
	Unstable or uneven braking	<ul style="list-style-type: none"> ● ABSCM&H/U (solenoid valve) ● ABS sensor ● Brake (caliper & piston, pads) ● Tire specifications, tire wear and air pressures ● Incorrect wiring or piping connections ● Road surface (uneven)
	Excessive pedal vibration	<ul style="list-style-type: none"> ● Incorrect wiring or piping connections ● Road surface (uneven)
Vibration and/or noise (while driving on slippery roads)	Noise from ABSCM&H/U	<ul style="list-style-type: none"> ● ABSCM&H/U (mount bushing) ● ABS sensor ● Brake piping
	Noise from front of vehicle	<ul style="list-style-type: none"> ● ABSCM&H/U (mount bushing) ● ABS sensor ● Master cylinder ● Brake (caliper & piston, pads, rotor) ● Brake piping ● Brake booster & check valve ● Suspension play or fatigue
	Noise from rear of vehicle	<ul style="list-style-type: none"> ● ABS sensor ● Brake (caliper & piston, pads, rotor) ● Parking brake ● Brake piping ● Suspension play or fatigue

**B: CHECKING THE HYDRAULIC
UNIT OPERATION****11B1 : PREPARING THE BRAKE TESTER.**

- CHECK** : *Is the brake tester available?*
- YES** : CHECKING THE HYDRAULIC UNIT
ABS OPERATION WITH BRAKE
TESTER <Ref. to 4-4 [W14C2].>
- NO** : CHECKING THE HYDRAULIC UNIT
ABS OPERATION BY PRESSURE
GAUGE <Ref. to 4-4 [W14C1].>

MEMO: