

BODY SECTION

This service manual has been prepared to provide SUBARU service personnel with the necessary information and data for the correct maintenance and repair of SUBARU vehicles.

This manual includes the procedures for maintenance, disassembling, reassembling, inspection and adjustment of components and diagnostics for guidance of experienced mechanics.

Please peruse and utilize this manual fully to ensure complete repair work for satisfying our customers by keeping their vehicle in optimum condition. When replacement of parts during repair work is needed, be sure to use SUBARU genuine parts.

All information, illustration and specifications contained in this manual are based on the latest product information available at the time of publication approval.

**HVAC SYSTEM
(HEATER, VENTILATOR AND A/C)** AC

**HVAC SYSTEM (AUTO A/C)
(DIAGNOSTICS)** AC

AIRBAG SYSTEM AB

AIRBAG SYSTEM (DIAGNOSTICS) AB

SEAT BELT SYSTEM SB

LIGHTING SYSTEM LI

WIPER AND WASHER SYSTEMS WW

ENTERTAINMENT ET

COMMUNICATION SYSTEM COM

GLASS/WINDOWS/MIRRORS GW

BODY STRUCTURE BS

INSTRUMENTATION/DRIVER INFO IDI

SEATS SE

SECURITY AND LOCKS SL

IMMOBILIZER (DIAGNOSTICS) IM

**SUNROOF/T-TOP/CONVERTIBLE TOP
(SUNROOF)** SR

EXTERIOR/INTERIOR TRIM EI

BODY SECTION

EXTERIOR BODY PANELS

EB

CRUISE CONTROL SYSTEM

CC

**CRUISE CONTROL SYSTEM
(DIAGNOSTICS)**

CC

EXTERIOR BODY PANELS



| | Page |
|------------------------------|-------------|
| 1. General Description | 2 |
| 2. Front Hood | 9 |
| 3. Fender Panel..... | 10 |
| 4. Front Door Panel..... | 11 |
| 5. Front Sealing Cover | 13 |
| 6. Rear Door Panel | 14 |
| 7. Rear Sealing Cover..... | 16 |
| 8. Trunk Lid Panel | 17 |
| 9. Rear Gate Panel | 18 |

GENERAL DESCRIPTION

EXTERIOR BODY PANELS

1. General Description

A: SPECIFICATIONS

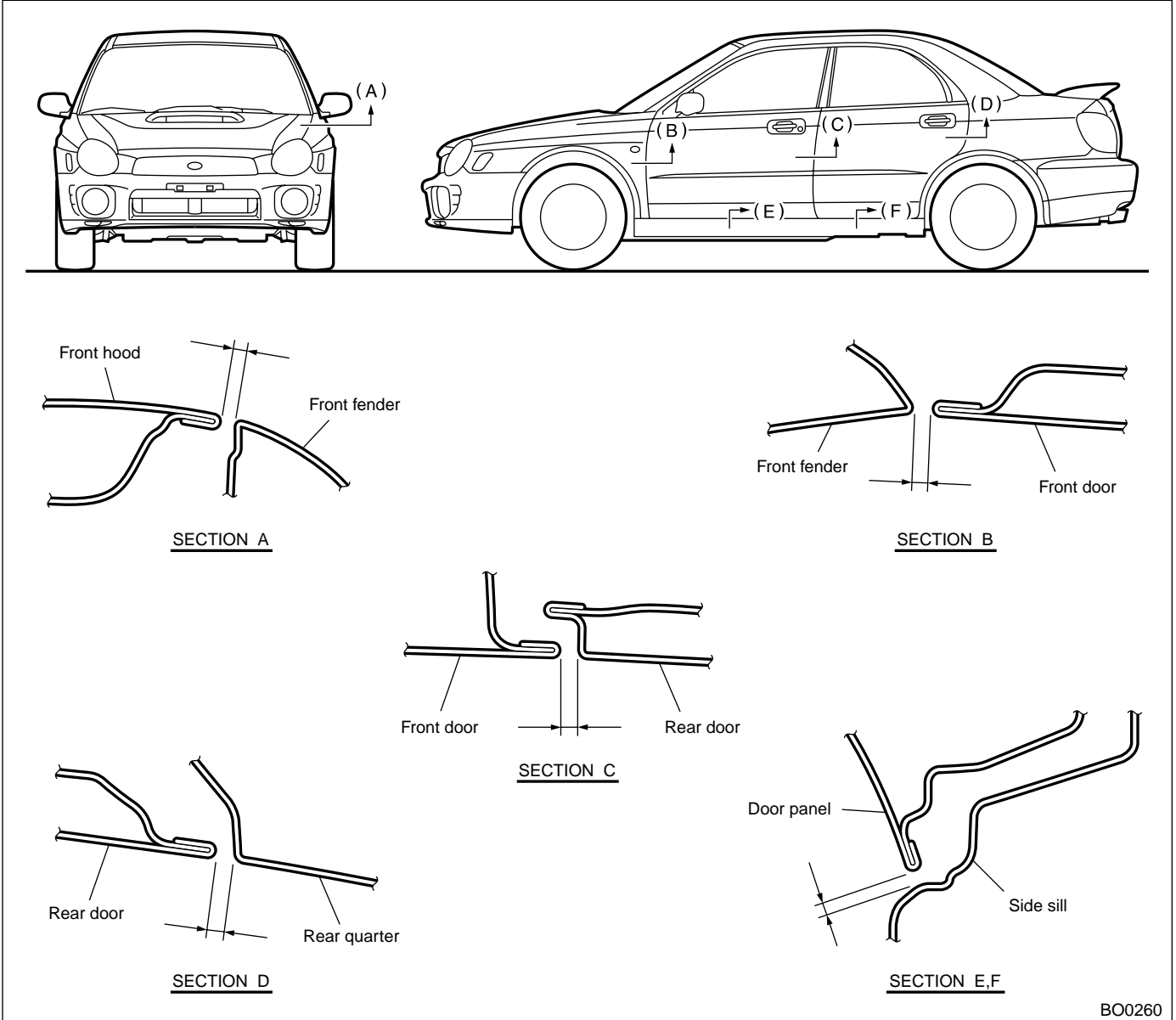

| Section | Part | Specification |
|---------|----------------------------|---|
| A | Front hood to Front fender | NA: 4.0 ± 1.0 (0.16 \pm 0.04 in) TURBO: 3.7 ± 1.0 (0.15 \pm 0.04 in) |
| B | Front fender to Front door | 4.7 ± 1.0 (0.19 \pm 0.04 in) |
| C | Front door to Rear door | 5.1 (0.20 in) |
| D | Rear door to Rear quarter | 4.6 (0.18 in) |
| E, F | Door panel to Side sill | 5.9 (0.23 in) |

B: COMPONENT

1. FRONT HOOD

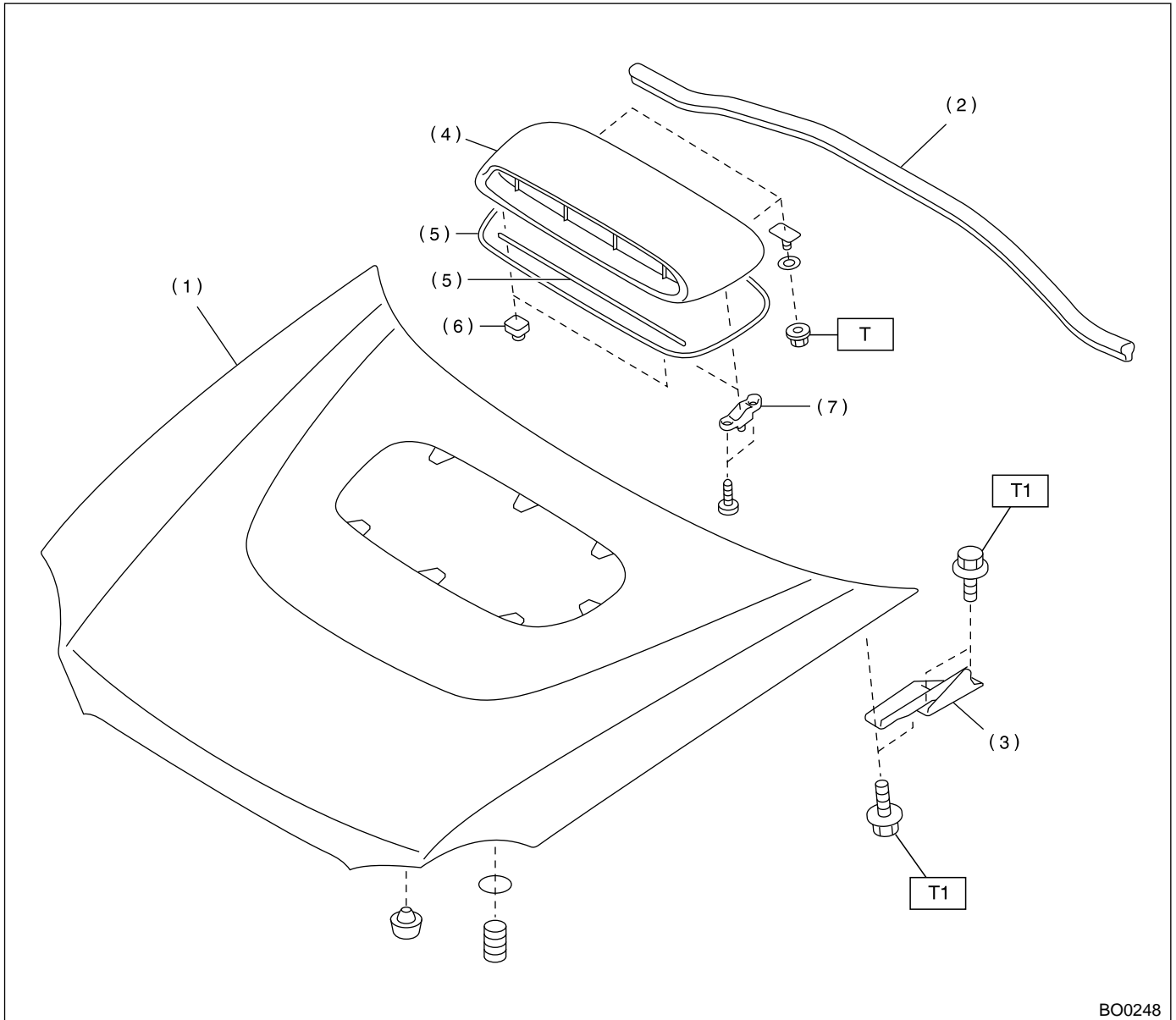

BO0248

- | | |
|-----------------------|-------------------|
| (1) Front hood | (5) Packing |
| (2) Seal (Front hood) | (6) Clip |
| (3) Hinge | (7) Locking piece |
| (4) Hood grille | |

Tightening torque: N-m (kg-m, ft-lb)

T: 7.35 (0.75, 5.4)

T1: 24.5 (2.5, 18.1)

GENERAL DESCRIPTION

EXTERIOR BODY PANELS

2. FRONT DOOR PANEL

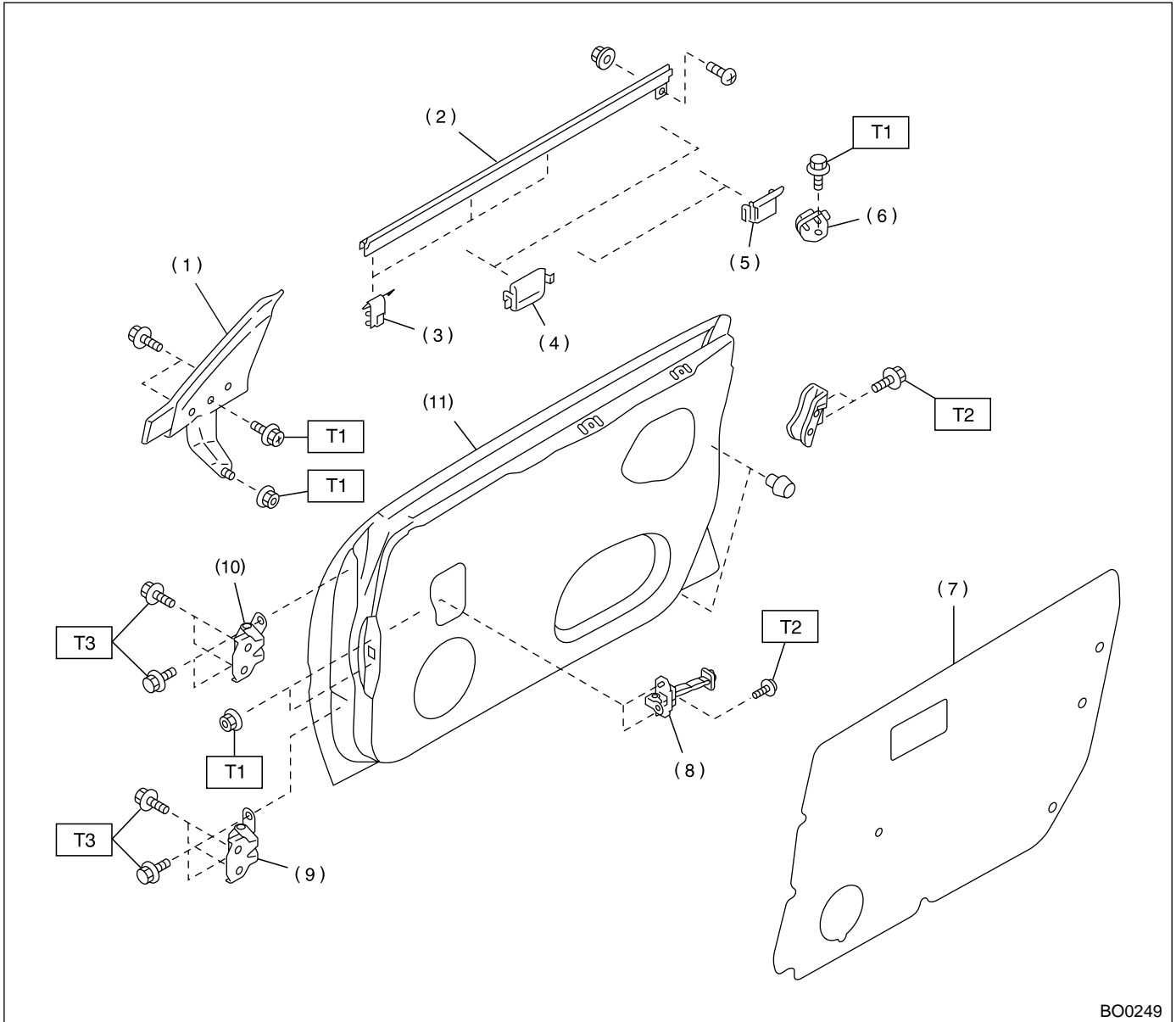

BO0249

- | | |
|--------------------------------|-------------------|
| (1) Gusset | (7) Sealing cover |
| (2) Weatherstrip (Outer) | (8) Checker |
| (3) Clip (Weatherstrip, outer) | (9) Lower hinge |
| (4) Stabilizer (Lifter) | (10) Upper hinge |
| (5) Stabilizer (Outer) | (11) Door panel |
| (6) Stabilizer (Inner) | |

Tightening torque: N·m (kg·m, ft·lb)

T1: 7.35 (0.75, 5.4)

T2: 18 (1.8, 13)

T3: 30 (3.1, 2.2)

3. REAR DOOR PANEL

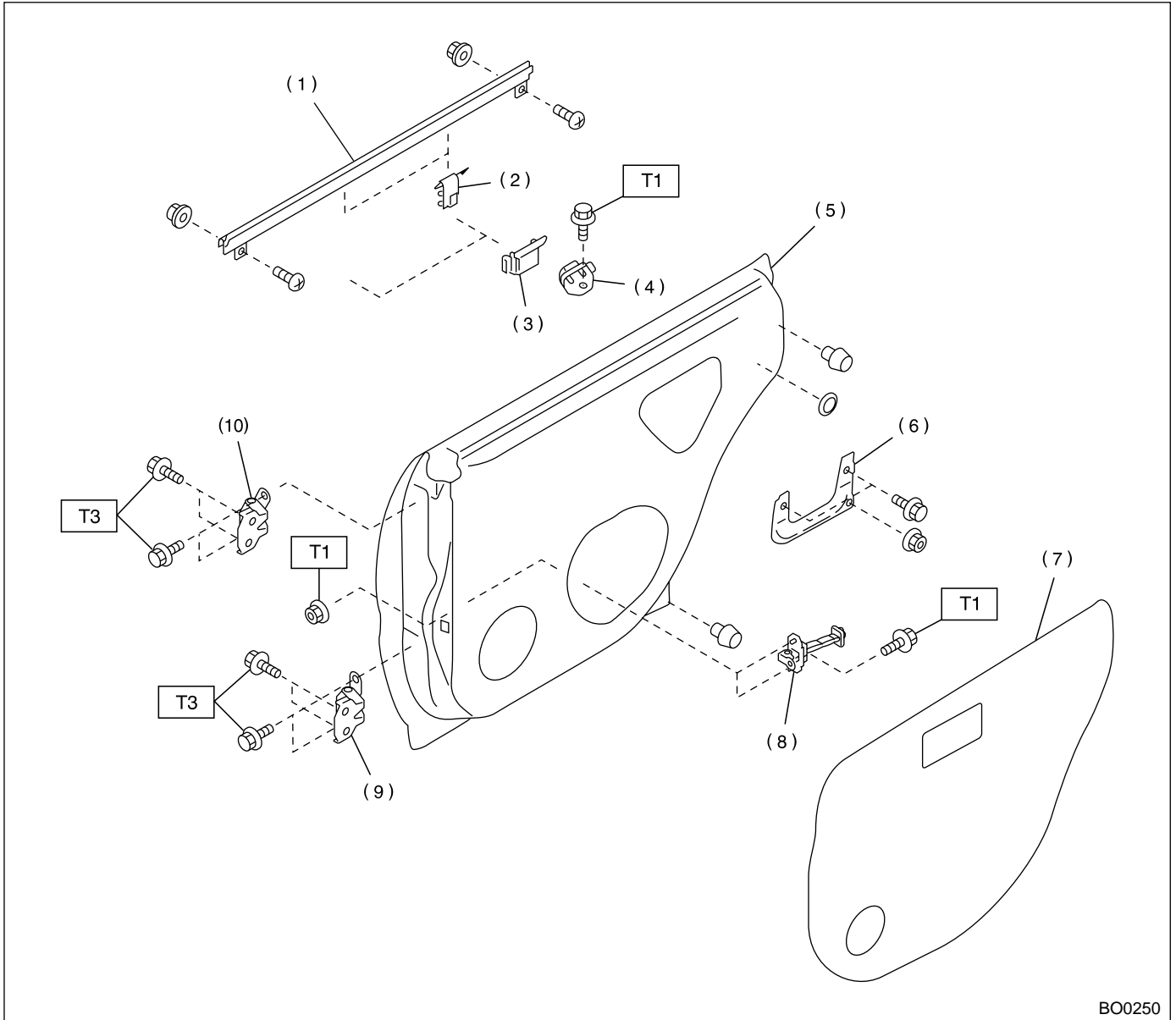

- | | |
|--------------------------------|-------------------|
| (1) Weatherstrip (Outer) | (7) Sealing cover |
| (2) Clip (Weatherstrip, outer) | (8) Checker |
| (3) Stabilizer (Outer) | (9) Lower hinge |
| (4) Stabilizer (Inner) | (10) Upper hinge |
| (5) Door panel | |
| (6) Bracket | |

Tightening torque: N·m (kg·m, ft·lb)

T1: 7.35 (0.75, 5.4)

T2: 18 (1.8, 13)

T3: 30 (3.1, 2.2)

GENERAL DESCRIPTION

EXTERIOR BODY PANELS

4. TRUNK LID PANEL

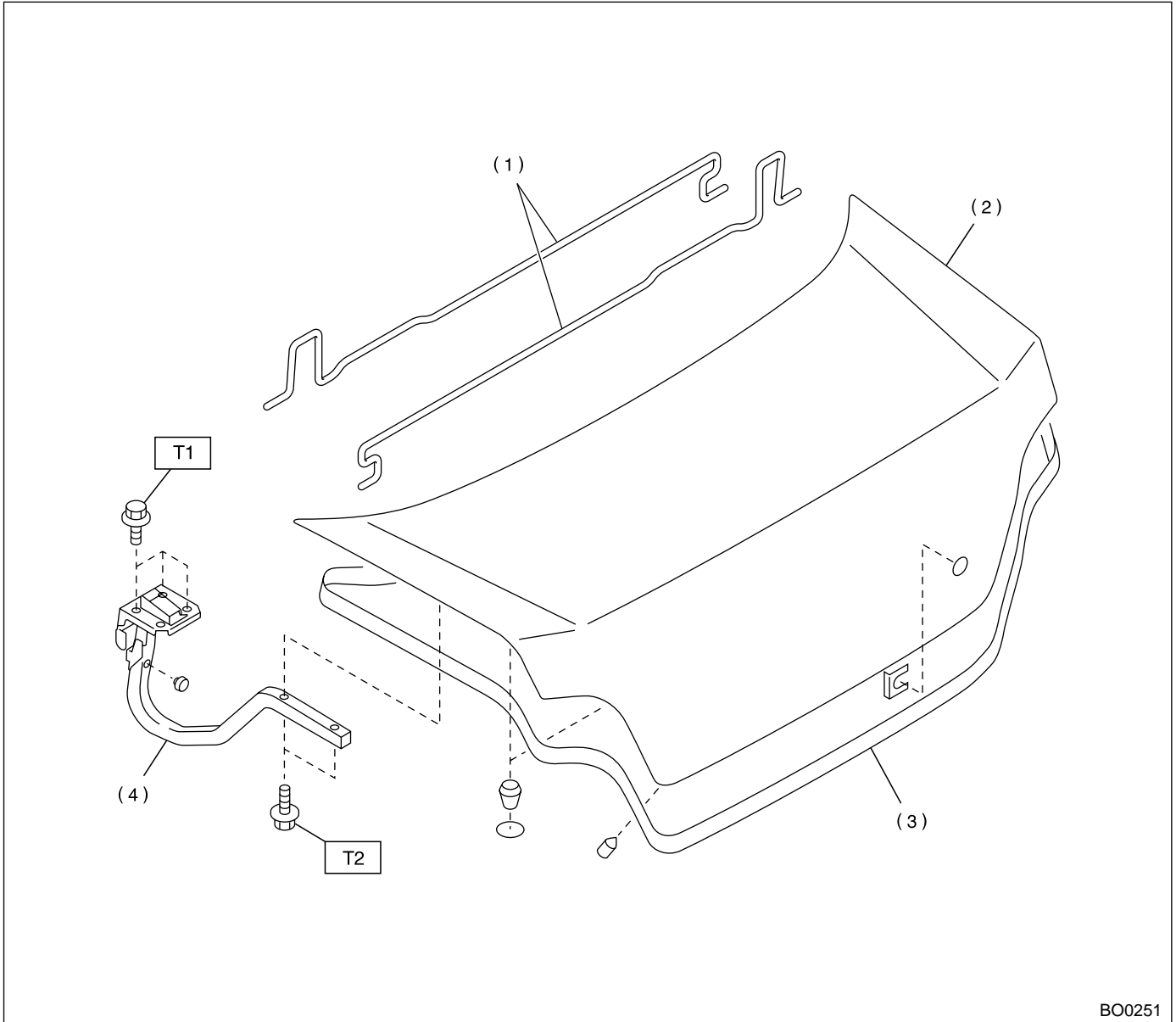

- (1) Torsion bar
- (2) Trunk lid
- (3) Weatherstrip

- (4) Hinge ASSY
- (5) Cover

Tightening torque: N·m (kg·m, ft·lb)

T1: 7.5 (0.76, 5.5)

T2: 14 (1.8, 13)

5. REAR GATE PANEL

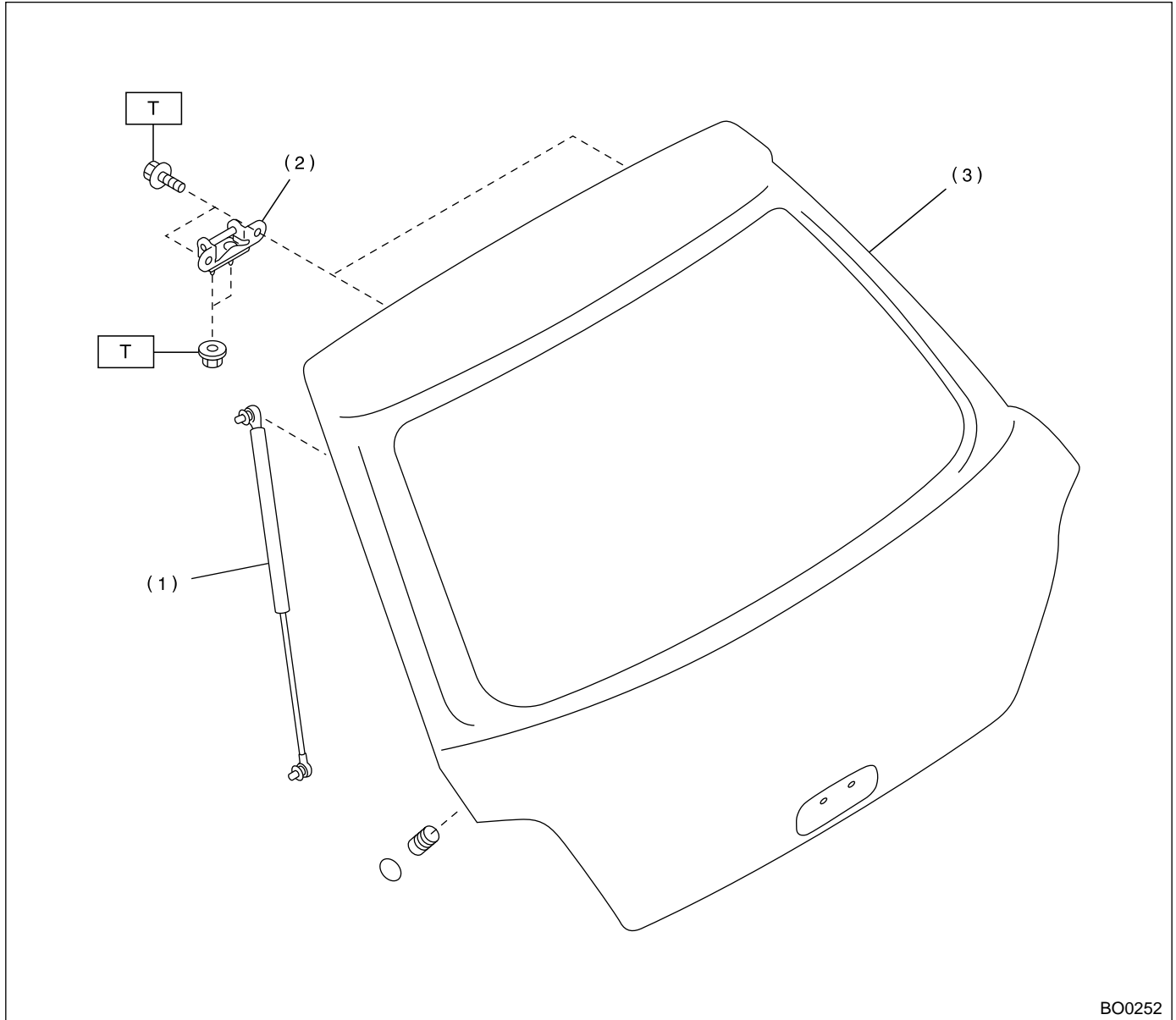

BO0252

- (1) Gas stay
- (2) Hinge
- (3) Rear gate

Tightening torque: N·m (kg·m, ft·lb)

T: 25 (2.5, 18.1)

C: CAUTION

- Exterior body panels are heavy. Do not drop and damage the panels. During removal and installation, do not damage the panel painting surface.
- While removing mounting bolts, using assistance devices such as a support jack will help support the panel.
- Be careful not to lose small parts.

GENERAL DESCRIPTION

EXTERIOR BODY PANELS

D: PREPARATION TOOL

1. SPECIAL TOOLS

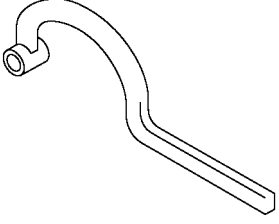
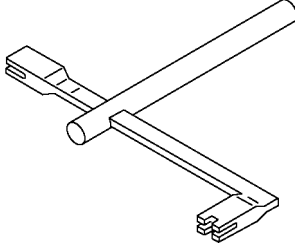
| ILLUSTRATION | TOOL NUMBER | DESCRIPTION | REMARKS |
|---|-------------|-------------|---|
|  B5M1117 | 925610000 | WRENCH | Used for removing and installing door hing. |
|  B5M1118 | 927780000 | REMOVER | Used for removing and installing trunk torsion bar. |

2. GENERAL TOOL

| TOOL NAME | REMARKS |
|--------------|---------------------------------|
| Support Jack | Used for supporting door panel. |

2. Front Hood

A: REMOVAL

- 1) Open front hood to remove washer nozzles.
- 2) Release clips to remove hood insulator.

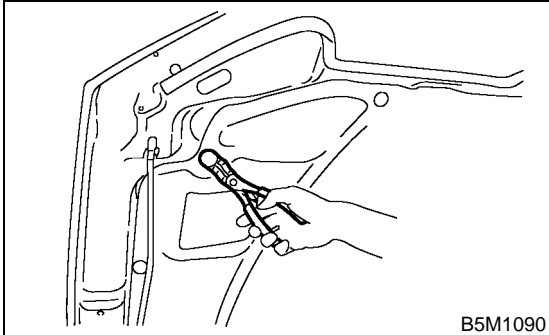

- 3) Remove bolts to disconnect hood from hinges.

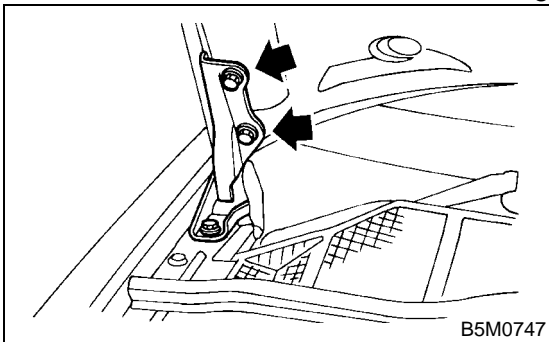

B: INSTALLATION

- 1) Install in the reverse order of removal.
- 2) Adjust clearance between hood and fender. Clearance must be equal at both sides.

C: ADJUSTMENT

- 1) Use hinge mounting holes to align front hood longitudinally and laterally.

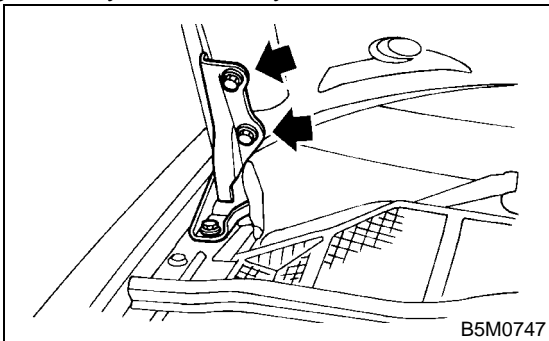

- 2) Adjust height at front end of hood. <Ref. to SL-40, ADJUSTMENT, Front Hood Lock Assembly.>

- 3) Rotate hood buffer to adjust lateral height.

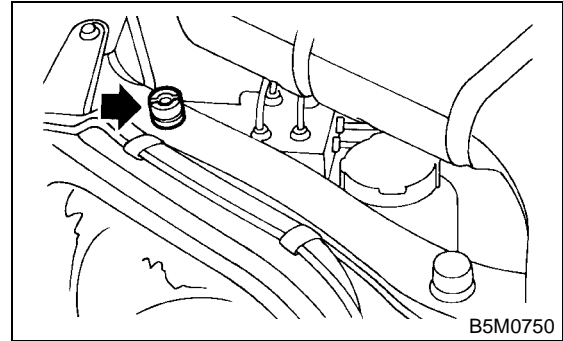

3. Fender Panel

A: REMOVAL

- 1) Disconnect ground (-) cable from battery.
- 2) Remove side sill spoilers. <Ref. to EI-19, Side Sill Spoiler.> (If fitted)
- 3) Remove front bumper face. <Ref. to EI-8, REMOVAL, Front Bumper.>
- 4) Remove mud guard. <Ref. to EI-16, REMOVAL, Mud Guard.>
- 5) Loosen bolts to remove front fender.

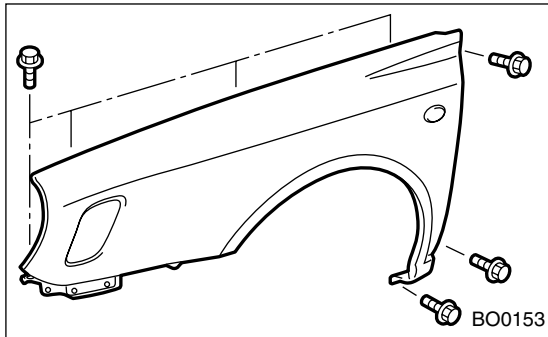

B: INSTALLATION

- 1) Install in the reverse order of removal.
- 2) When fender panel is installed, clearance between fender panel and hood or front fender must be equal.

4. Front Door Panel

A: REMOVAL

- 1) Disconnect ground cable from battery.
- 2) Remove front door trim. <Ref. to EI-20, REMOVAL, Front Door Trim.>
- 3) Remove outer mirror assembly. <Ref. to GW-46, REMOVAL, Outer Mirror Assembly.>
- 4) Remove front door regulator and motor. <Ref. to GW-31, REMOVAL, Front Regulator and Motor Assembly.>
- 5) Remove front door latch assembly. <Ref. to SL-30, REMOVAL, Front Door Latch Assembly.>
- 6) Remove front outer handle. <Ref. to SL-29, REMOVAL, Front Outer Handle.>
- 7) Remove front pillar lower trim to disconnect connector from body harness.

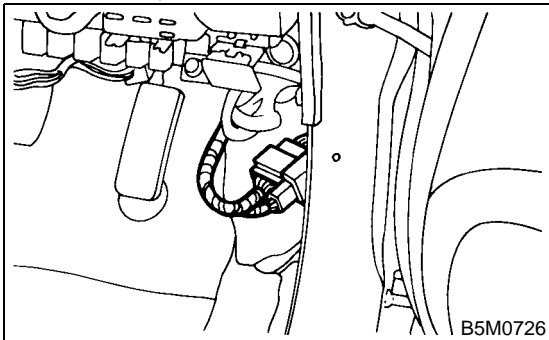

- 8) Put wooden block on jack and place jack under door. Support door with a support jack to protect it from damage.

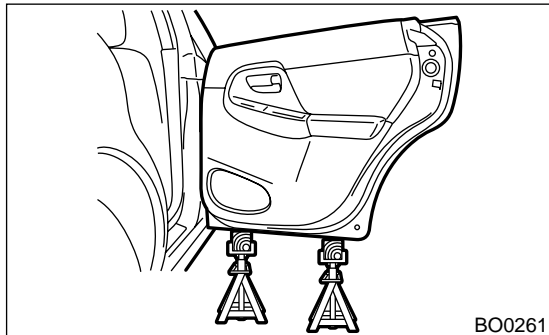

- 9) Remove checker bolts.

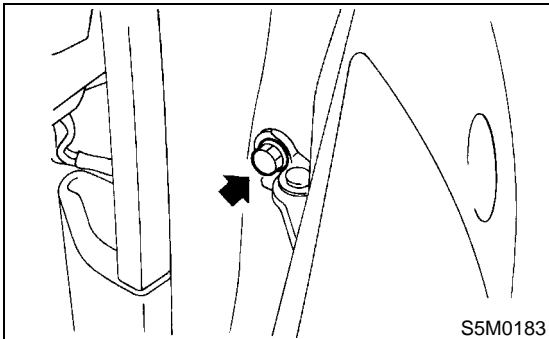

- 10) Remove door-side bolts for upper and lower hinges to remove door.

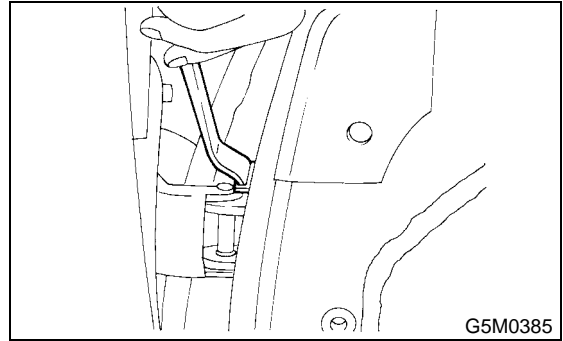

- 11) Using special tool, remove body-side bolts for upper and lower hinges, and remove door hinges. ST 925610000 DOOR HINGE WRENCH

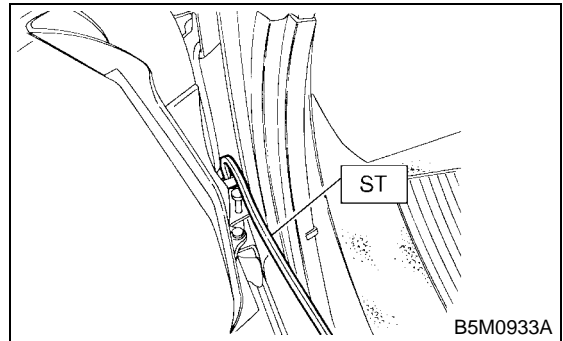

CAUTION:

- During removal and installation of doors, do not damage body.
- Doors are heavy. Be careful not to drop and damage them.

B: INSTALLATION

- 1) Install in the reverse order of removal.
- 2) Apply grease to sliding area of door hinges.

FRONT DOOR PANEL

EXTERIOR BODY PANELS

C: ADJUSTMENT

1) Using special tool, loosen body-side bolts of upper and lower hinges to align the position of front door panel longitudinally and vertically.

ST 925610000 DOOR HINGE WRENCH

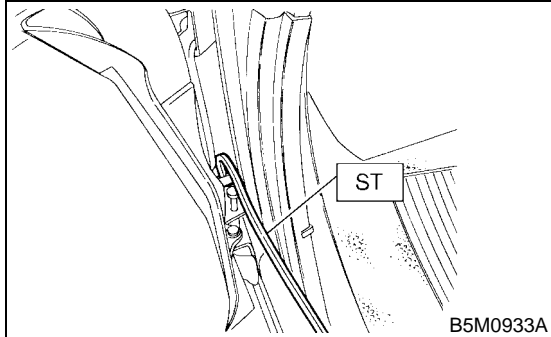

2) Loosen door-side bolts of upper and lower hinges to align the position of front door panel vertically and laterally at the front end.

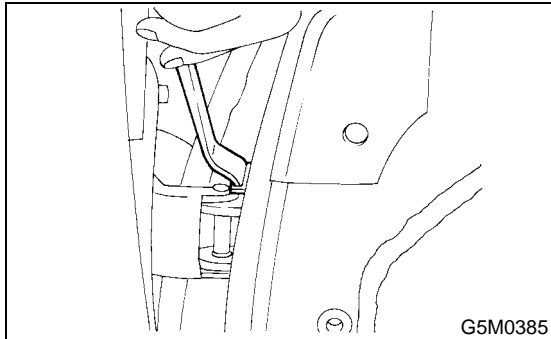

3) Loosen screw (A) and tap striker (B) using plastic hammer to adjust striker.

CAUTION:

Do not use impact wrench. Welding area on striker nut plate is easily broken.

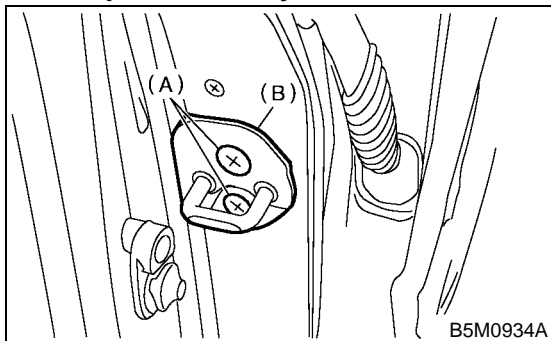

5. Front Sealing Cover

A: REMOVAL

- 1) Remove front door trim. <Ref. to EI-20, REMOVAL, Front Door Trim.>
- 2) Remove front speaker. <Ref. to ET-10, REMOVAL, Front Speaker.>
- 3) Using a spatula, remove sealer.

CAUTION:

- Carefully remove sealer. Excessive force will easily break the cover.
- If cover gets broken, replace it with a new one.

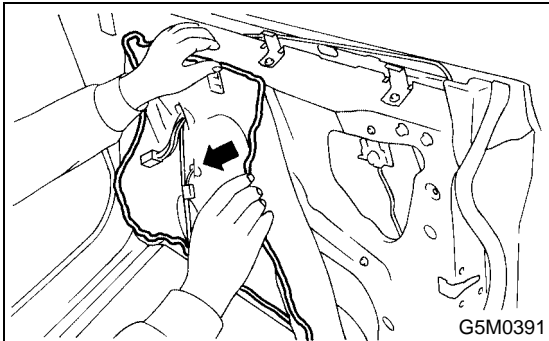

B: INSTALLATION

- 1) Install in the reverse order of removal.
- 2) When replacing sealing cover, use CEMEDINE 5430L sealer.
- 3) Press sealer-applied area firmly to prevent any floating on surface.

Sealer:

CEMEDINE 5430L or equivalent

CAUTION:

- Apply a uniform bead of sealer.
- Attach sealing cover, keeping it from becoming wrinkled.
- Breaks in the bead will allow water leakage and contamination.

C: INSPECTION

If sealing cover is damaged, replace it with a new one.

REAR DOOR PANEL

EXTERIOR BODY PANELS

6. Rear Door Panel

A: REMOVAL

CAUTION:

- During removal and installation of doors, do not damage body.
- Doors are heavy. Be careful not to drop and damage them.

- 1) Disconnect ground cable from battery.
- 2) Remove rear door trim. <Ref. to EI-21, REMOVAL, Rear Door Trim.>
- 3) Remove rear door regulator and motor assembly. <Ref. to GW-34, REMOVAL, Rear Regulator and Motor Assembly.>
- 4) Remove rear door latch. <Ref. to SL-34, REMOVAL, Rear Door Latch Assembly.>
- 5) Remove rear outer handle. <Ref. to SL-33, REMOVAL, Rear Outer Handle.>
- 6) Remove center pillar lower trim. <Ref. to EI-29, REMOVAL, Lower Inner Trim.>
- 7) Disconnect connector of door harness.



- 8) Put a wooden block on the jack and place the jack under the door. Support the door with the jack to protect it.

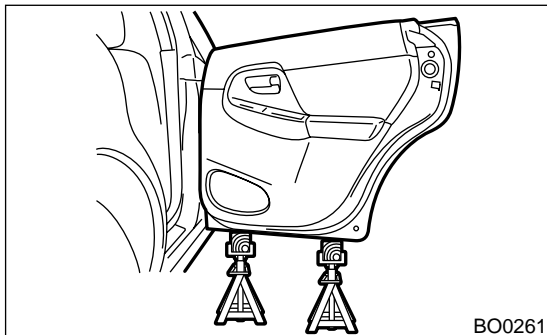

- 9) Remove checker bolts.

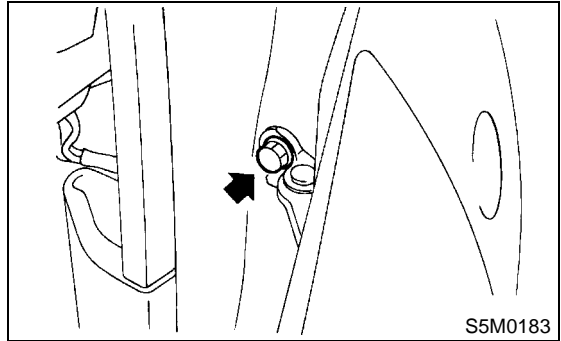

- 10) Remove door-side bolts for upper and lower hinges to remove door.

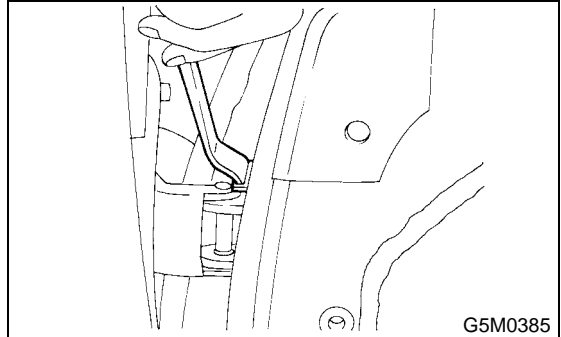

- 11) Using special tool, remove body-side bolts for upper and lower hinges, and remove door hinges.

B: INSTALLATION

- 1) Install in the reverse order of removal.
- 2) Apply grease to sliding area of door hinges.

C: ADJUSTMENT

1) Using special tool, loosen body-side bolts of upper and lower hinges to align the position of rear door panel longitudinally and vertically.

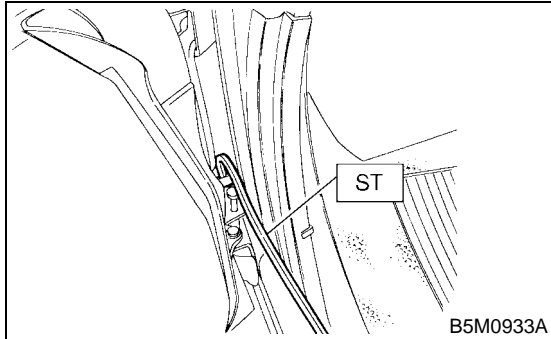

2) Loosen door-side bolts of upper and lower hinges to align the position of rear door panel vertically and laterally at front-end.

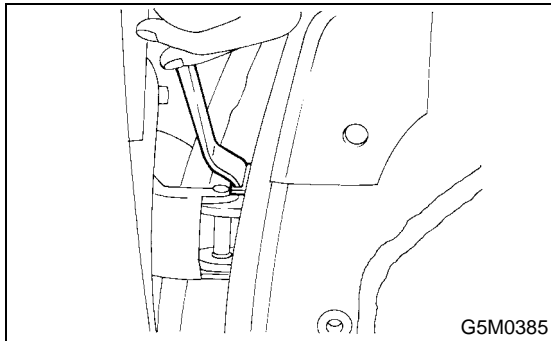

3) Loosen screw (A) and tap striker (B) using plastic hammer to adjust striker.

CAUTION:

Do not use an impact wrench. The welding area on the striker nut plate is easily broken.

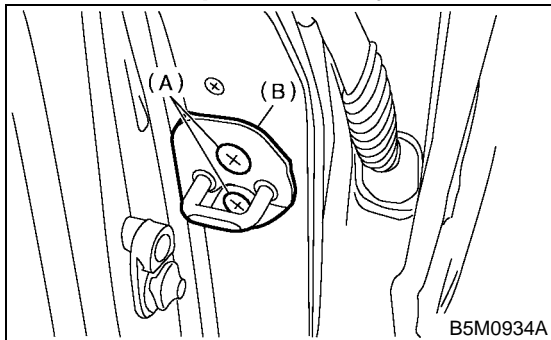

7. Rear Sealing Cover

A: REMOVAL

- 1) Remove rear door trim. <Ref. to EI-21, REMOVAL, Rear Door Trim.>
- 2) Remove rear speaker. <Ref. to ET-12, REMOVAL, Rear Speaker.>
- 3) Using a spatula, remove sealer.

CAUTION:

- Carefully remove sealer. Excessive force will easily break the cover.
- If cover gets broken, replace it with a new one.

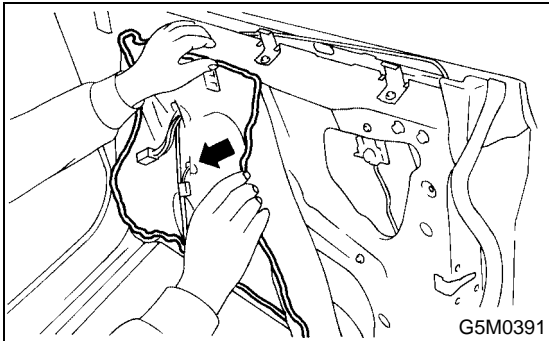

B: INSTALLATION

- 1) Install in the reverse order of removal.
- 2) When replacing sealing cover, use CEMEDINE 5430L sealer.
- 3) Press sealer-applied area firmly to prevent any floating on surface.

Sealer:

CEMEDINE 5430L or equivalent

CAUTION:

- Apply an uniform bead of sealer.
- Attach sealing cover, keeping it from becoming wrinkled.
- Breaks in the bead will allow water leakage and contamination.

C: INSPECTION

If sealing cover gets damaged, replace it with a new one.

8. Trunk Lid Panel

A: REMOVAL

1. TRUNK LID

- 1) Open trunk lid.
- 2) Disconnect trunk lid connector.
- 3) Loosen trunk lid mounting bolts to remove trunk lid from hinges.

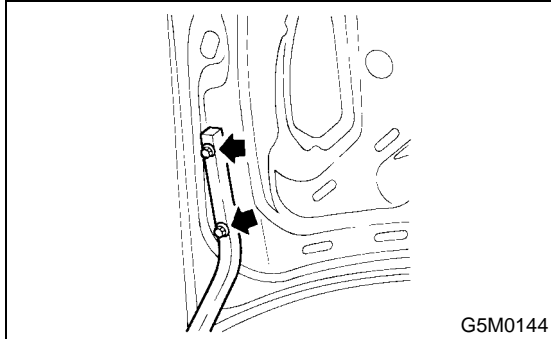

2. TORSION BAR

- 1) Open trunk lid.
- 2) Using special tool, remove torsion bar from hinge link.

ST 927780000 REMOVER

CAUTION:

During removal and installation, carefully handle torsion bar. It will generate reactive force.

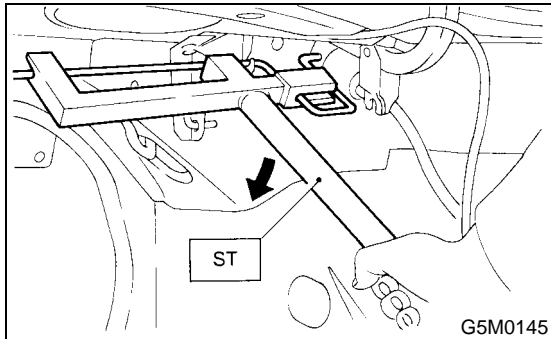

- 3) Remove right/left torsion bars.

CAUTION:

After the torsion bar is removed, the trunk lid will slam shut. Be careful not to get hit by the trunk lid.

B: INSTALLATION

1. TRUNK LID

- 1) Install in the reverse order of removal.
- 2) Install trunk lid with uniform clearance.

2. TORSION BAR

- 1) Install in the reverse order of removal.
- 2) Apply grease to rotating area of hinges and mating surface of torsion bar.

REAR GATE PANEL

EXTERIOR BODY PANELS

9. Rear Gate Panel

A: REMOVAL

1. REAR GATE PANEL

- 1) Open rear gate.
- 2) Remove rear gate outer handle. <Ref. to SL-36, REMOVAL, Rear Gate Outer Handle.>
- 3) Remove rear gate latch assembly. <Ref. to SL-37, REMOVAL, Rear Gate Latch Assembly.>
- 4) Remove rear gate key lock cylinders. <Ref. to SL-43, REAR GATE, REPLACEMENT, Key Lock Cylinders.>
- 5) Remove rear wiper. <Ref. to WW-21, REMOVAL, Rear Wiper Motor.>
- 6) Disconnect connectors of rear wiper, rear defogger, and other lighting devices.
- 7) Disconnect washer hose.
- 8) Remove rubber duct (A) connection, and pull out harness and washer hose from rear gate.

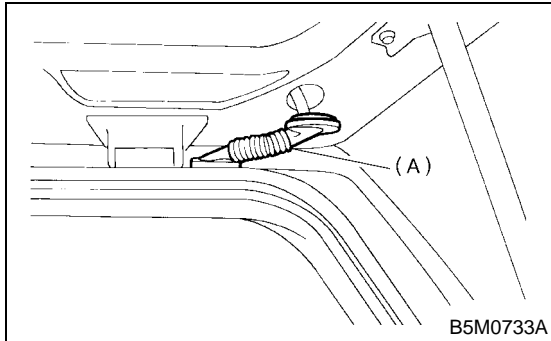

- 9) Using a support, support the rear gate while removing gas stay mounting bolts.

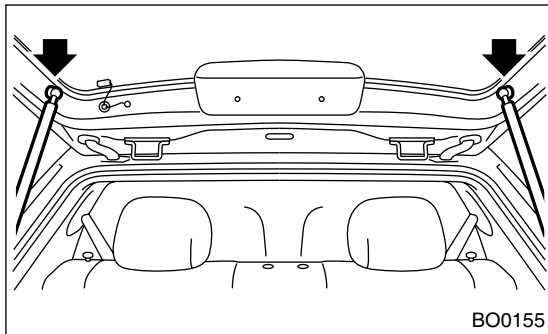
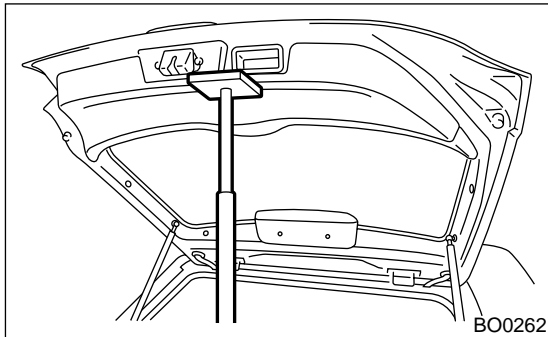

CAUTION:

When the rear gate is released, it may hit and damage the body. To prevent this, place a shop cloth between body and gate.

- 10) Loosen rear gate bolts to remove rear gate.

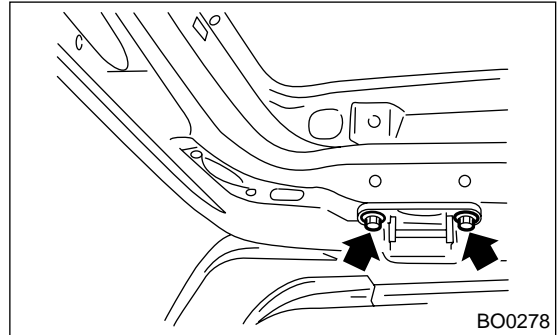

2. GAS STAY

- 1) Open rear gate. Using a support jack to support the rear gate.

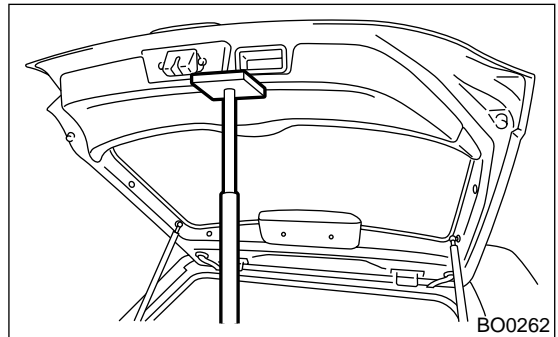

CAUTION:

- After gas stay is removed, rear gate cannot stay open. Supporting the rear gate with a jack, remove the bolts.
- Do not damage piston rods and oil seals.
- Never disassemble cylinders: They contain gas.

2) Loosen bolts to remove gas stay from rear gate.

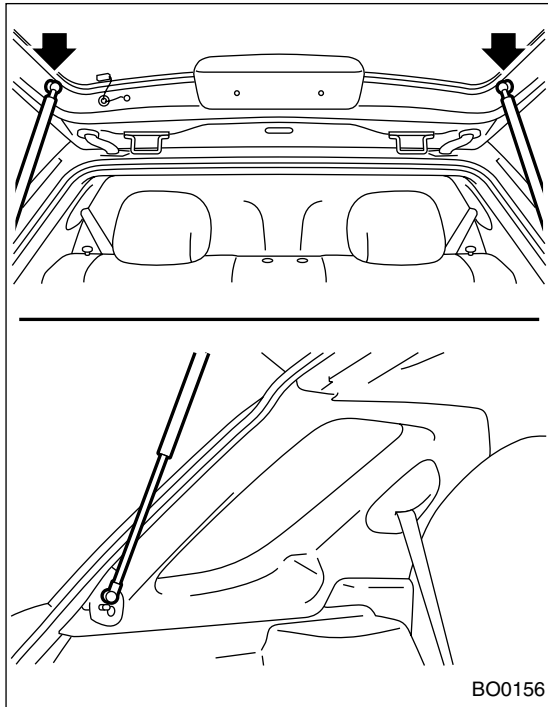

BO0156

1) Cover with a vinyl case as shown in the figure.

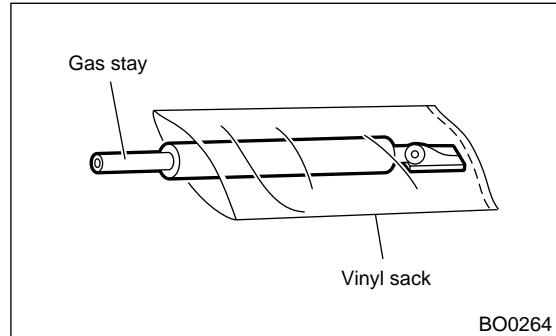

BO0264

CAUTION:
Prevent the vinyl case from being caught by drill cutting edge

2) Lift body side slightly with piston rods fully extended, and secure body side on vise stand.

Drill a hole in 2 to 3 mm (0.08 to 0.12 in) diameter at a point 10 to 200 mm (0.39 to 7.87 in) from door side, and bleed gas stay completely.

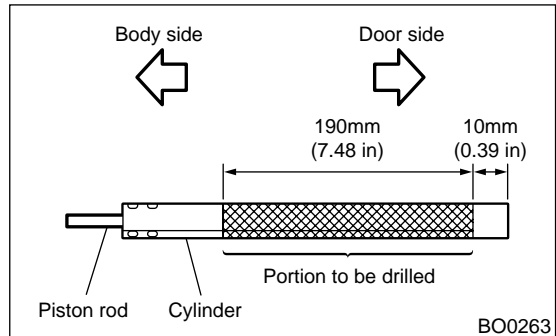

BO0263

B: INSTALLATION

1. REAR GATE PANEL

- 1) Install in the reverse order of removal.
- 2) Install rear gate panel with uniform clearance to body.

CAUTION:
Do not damage painted surfaces of body and rear gate.

2. GAS STAY

Install in the reverse order of removal.

CAUTION:
After supporting rear gate with a jack, start operation.

C: DISPOSAL

1. GAS STAY

CAUTION:
Gas is colorless, odorless, and harmless. However, gas pressure may spray cutting powder or oil. Be sure to wear dust-resistant goggles.

REAR GATE PANEL

EXTERIOR BODY PANELS
