

FRONT DIFFERENTIAL

Automatic Transmission

17. Front Differential S510152

A: REMOVAL S510152A18

1) Extract the torque converter clutch assembly.
<Ref. to AT-30 REMOVAL, Torque Converter Clutch Assembly.>

NOTE:

- Extract the torque converter clutch horizontally. Be careful not to scratch the bushing inside the oil pump shaft.
- Note that oil pump shaft also comes out.

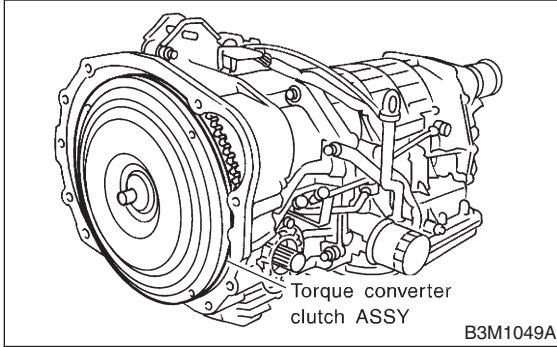

2) Remove the input shaft.

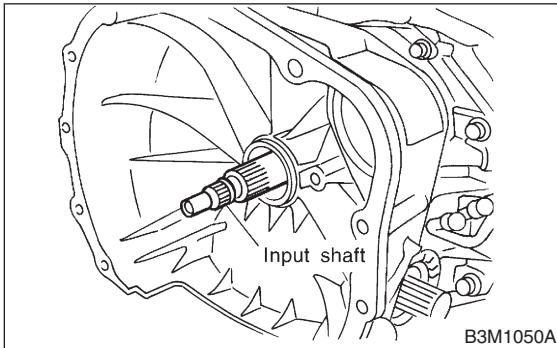

3) Disconnect transmission harness connector from stay.

NOTE:

Lift-up lever behind the connector and disconnect it from stay.

- 4) Disconnect inhibitor switch from stay.
- 5) Disconnect the air breather hose. <Ref. to AT-23 REMOVAL, Air Breather Hose.>
- 6) Remove the oil charger pipe, and remove the O-ring from the flange face. Attach the O-ring to the pipe. <Ref. to AT-24 REMOVAL, Oil Charger Pipe.>
- 7) Remove the oil cooler inlet and outlet pipes. <Ref. to AT-25 REMOVAL, Oil Cooler Pipes.>

8) Separation of torque converter clutch case and transmission case sections

CAUTION:

- Be careful not to damage the oil seal and bushing inside the torque converter clutch case by the oil pump cover.
- Be careful not to lose the rubber seal.

NOTE:

Separate these cases while tapping lightly on the housing.

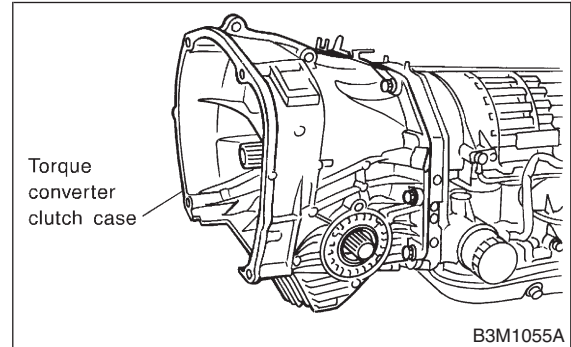

9) Wrap the axle shaft serration with vinyl tape.

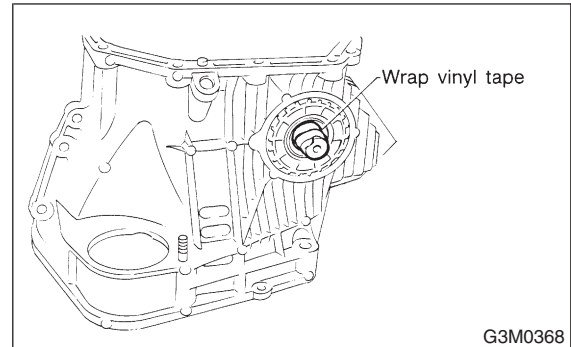

10) Remove the differential side retainer with ST.

CAUTION:

Hold the differential case assembly by hand to avoid damaging retainer mounting hole of the torque converter clutch case and speedometer gears.

ST 499787000 WRENCH ASSY

11) Extract the axle shaft with ST1 and ST2.

CAUTION:

Do not reuse the circlip.

ST1 499095500 REMOVER
ST2 499247300 INSTALLER

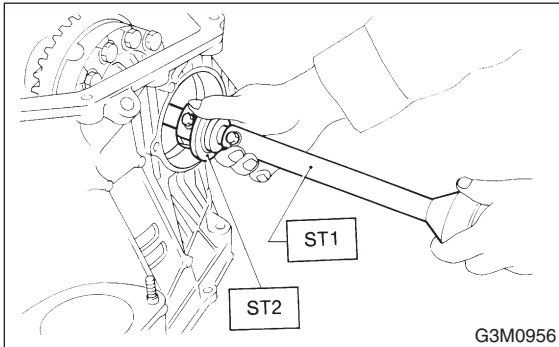

12) Remove the differential assembly.

CAUTION:

- Remove the seal pipe if it is attached. (Reusing is not allowed.)
- Be careful not to damage the retainer mounting hole of the torque converter clutch case.

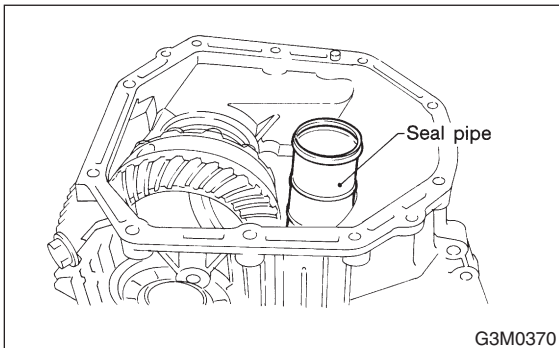

13) Remove the rubber seal.

B: INSTALLATION S510152A11

1) Install the differential assembly to the case, paying special attention not to damage the inside of the case (particularly, the differential side retainer contact surface).

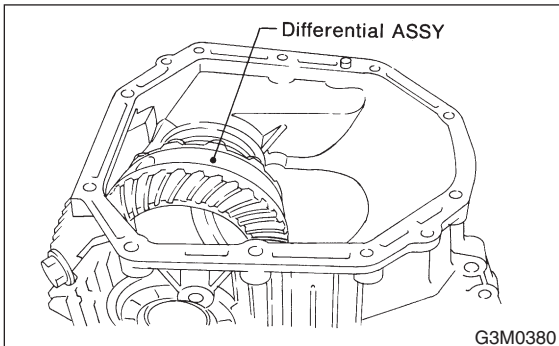

2) Install the circlip to the axle shaft, insert the shaft into the differential assembly, and tap it into position with a plastic hammer.

CAUTION:

- If no play is felt, check whether the shaft is fully inserted. If shaft insertion is correct, replace the axle shaft.
- Be sure to use a new circlip.

Thrust play:

0.3 — 0.5 mm (0.012 — 0.020 in)

3) Wrap vinyl tape around the splined portion of the axle shaft.

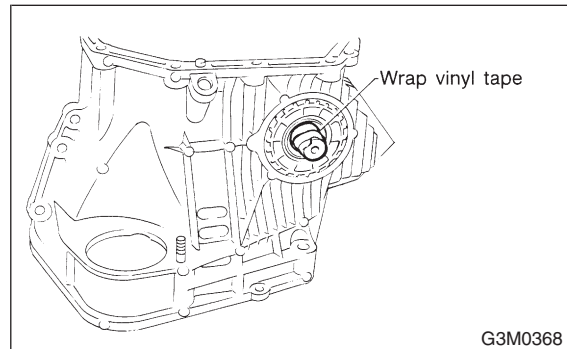

4) Install the oil seal and outer race (taper roller bearing) to the differential side retainer. Then screw in the retainer and the O-ring after coating the threads with oil.

CAUTION:

- Pay attention not to damage the oil seal lips.
- Do not confuse the RH and LH oil seals.
- Keep the O-ring removed from the retainer.

5) Using the ST, install the side retainers. <Ref. to AT-66 ADJUSTMENT, Front Differential.>

ST 499787000 WRENCH ASSY

6) Install the lock plate.

Tightening torque:

25 N·m (2.5 kgf·m, 18.1 ft·lb)

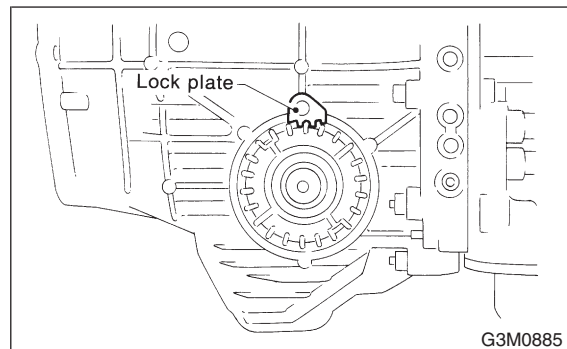

FRONT DIFFERENTIAL

Automatic Transmission

7) Install the seal pipe to the torque converter clutch case.

CAUTION:

Be sure to use a new seal pipe.

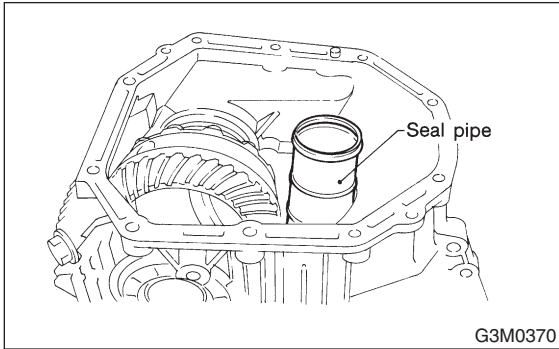

8) Install the rubber seal to the torque converter clutch case.

CAUTION:

Be careful not to lose the rubber seal.

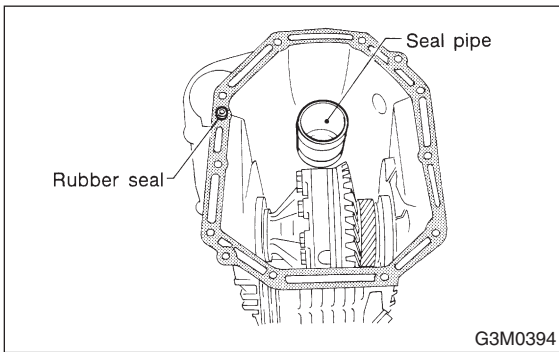

9) Apply proper amount of liquid gasket (THREE BOND Part No. 1215) to the entire torque converter clutch case mating surface.

NOTE:

Make sure that the rubber seal and seal pipe are fitted in position.

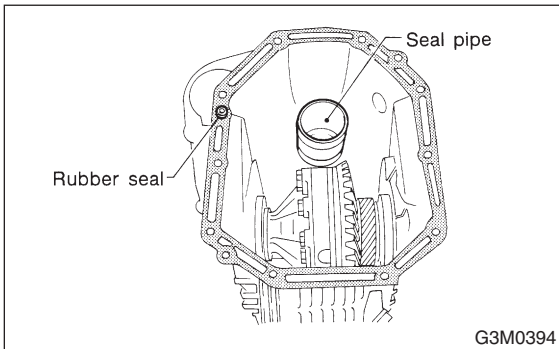

10) Install the torque converter clutch case assembly to the transmission case assembly, and secure with six bolts and four nuts.

CAUTION:

When installing, be careful not to damage the torque converter clutch case bushing and oil seal.

Tightening torque:

41 N·m (4.2 kgf-m, 30.4 ft-lb)

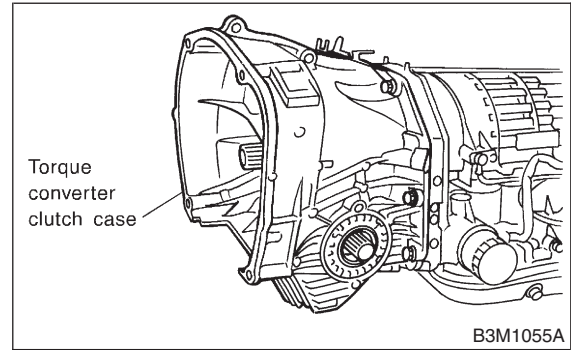

11) Install air breather hose.

12) Insert inhibitor switch and transmission connector into stay.

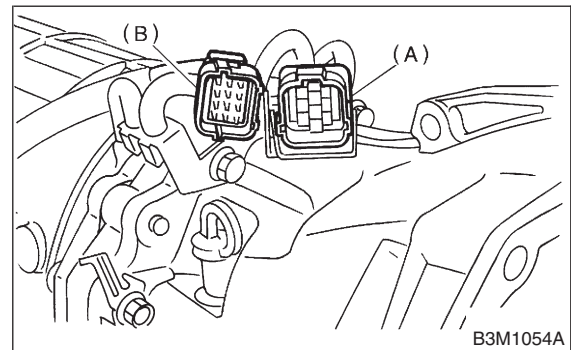

(A) Transmission harness

(B) Inhibitor switch harness

13) Install oil cooler pipes.

14) Install the oil charge pipe with O-ring

15) Insert the input shaft while turning lightly by hand.

CAUTION:

Be careful not to damage the bushing.

Normal protrusion A:

50 — 55 mm (1.97 — 2.17 in)

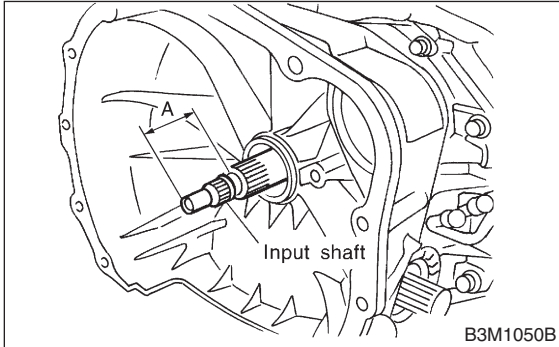

16) Install the torque converter clutch assembly.

C: DISASSEMBLY

S510152A06

1) Using a press and ST, remove the taper roller bearing.

ST 498077000 REMOVER

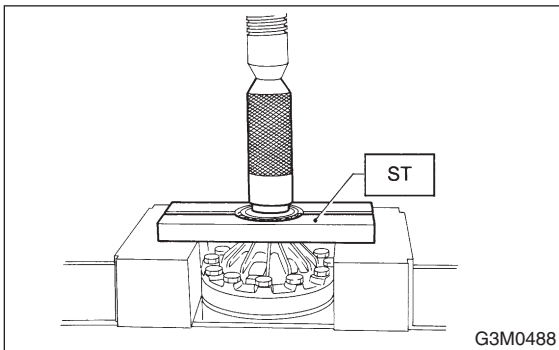

2) Secure the case in a vise and remove the crown gear tightening bolts, then separate the crown gear, case (RH) and case (LH).

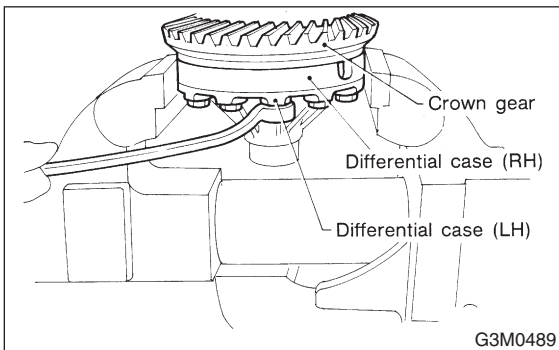

3) Pull out the straight pin and shaft, and remove the differential bevel gear, washer, and differential bevel pinion.

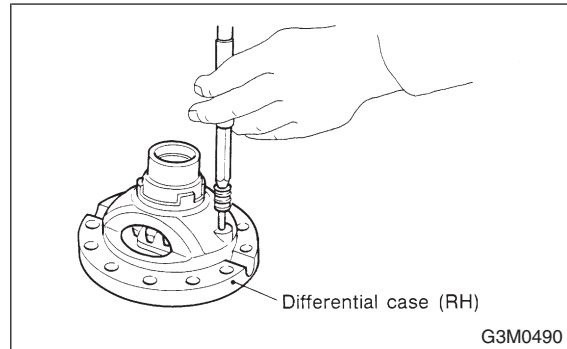

D: ASSEMBLY

S510152A02

1) Install the washer, differential bevel gear and differential bevel pinion in the differential case (RH). Insert the pinion shaft, and fit the straight pin.

NOTE:

Install straight pin from reverse direction.

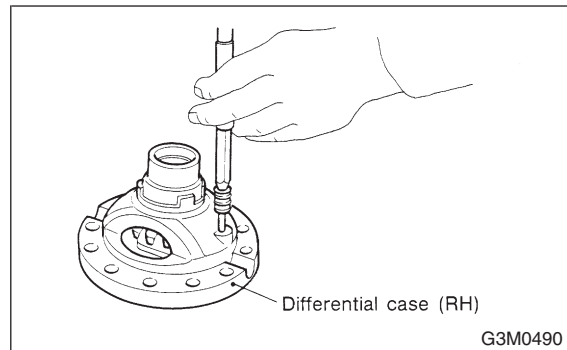

2) Install the washer and differential bevel gear to the differential case (LH). Then put the case over the differential case (RH), and connect both cases.
3) Install the crown gear and secure by tightening the bolt.

Standard tightening torque:

62 N·m (6.3 kgf·m, 45.6 ft·lb)

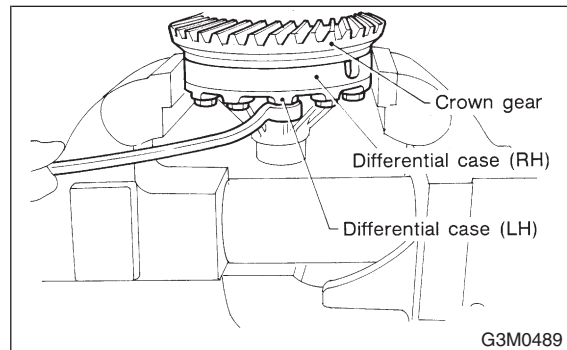

FRONT DIFFERENTIAL

Automatic Transmission

- 4) Measurement of backlash (Selection of washer)
Measure the gear backlash with ST1 and ST2, and insert ST2 through the access window of the case.
ST1 498247001 MAGNET BASE
ST2 498247100 DIAL GAUGE

NOTE:

Measure the backlash by applying a pinion tooth between two bevel gear teeth.

Standard value:

0.13 — 0.18 mm (0.0051 — 0.0071 in)

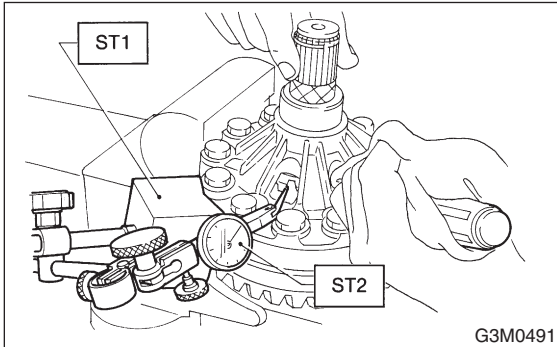

- 5) Using ST, install taper roller bearing.
ST 398487700 DRIFT

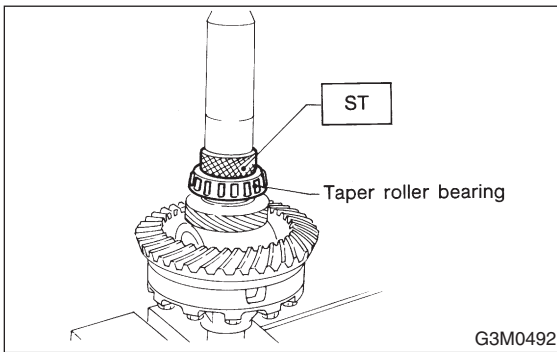

E: INSPECTION S510152A10

- Check each component for harmful cuts, damage and other faults.
- Measure the backlash and adjust to within specifications.

F: ADJUSTMENT S510152A01

- 1) Using the ST, screw in the retainer until light contact is felt.

NOTE:

Screw in the RH side slightly deeper than the LH side.

- ST 499787000 WRENCH ASSY

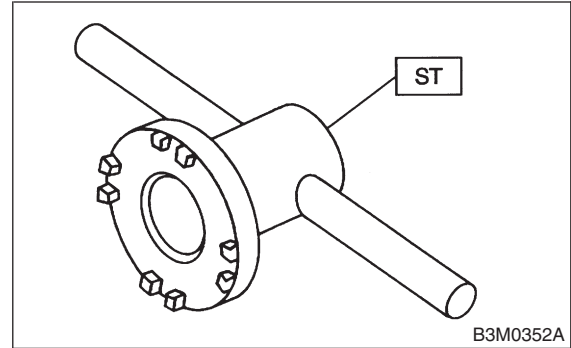

- 2) Remove the oil pump housing.
3) Install the oil pump housing assembly to the torque converter clutch case, and secure evenly by tightening four bolts.

CAUTION:

- Thoroughly remove the liquid gasket from the case mating surface beforehand.
- Use an old gasket or an aluminum washer so as not to damage the mating surface of the housing.

Tightening torque:

41 N·m (4.2 kgf·m, 30.4 ft·lb)

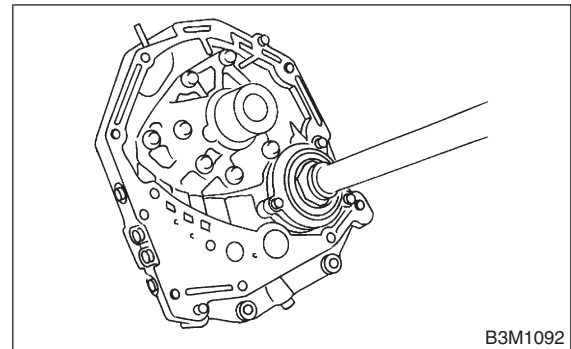

4) Rotate the drive pinion several times with ST1 and ST2.

ST1 498937110 HOLDER
ST2 499787700 WRENCH

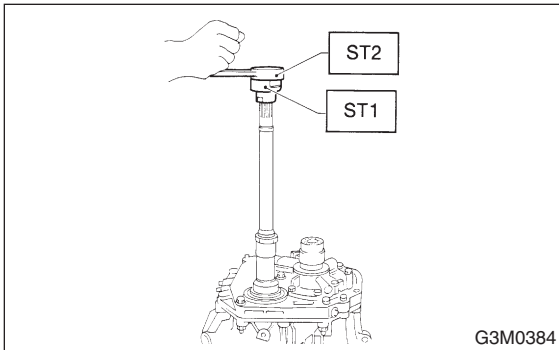

5) Tighten the LH retainer until contact is felt while rotating the shaft. Then loosen the RH retainer. Keep tightening the LH retainer and loosening the RH retainer until the pinion shaft can no longer be turned. This is the “zero” state.

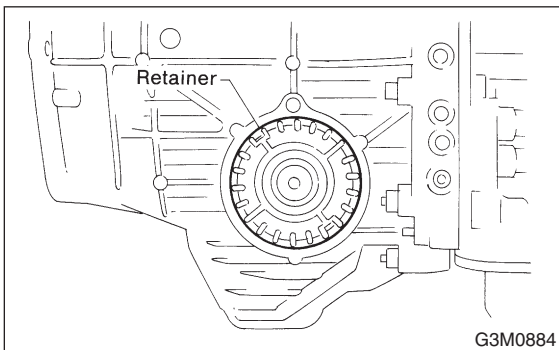

6) After the “zero” state is established, back off the LH retainer 3 notches and secure it with the lock plate. Then back off the RH retainer and retighten until it stops. Repeat this procedure several times. Tighten the RH retainer 1-3/4 notches further. This sets the preload. Finally, secure the retainer with its lock plate.

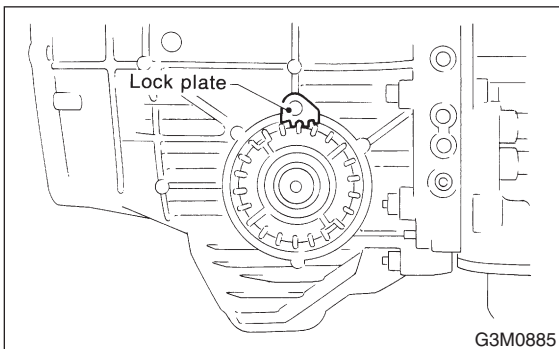

NOTE:

Turning the retainer by one tooth changes the backlash about 0.05 mm (0.0020 in).

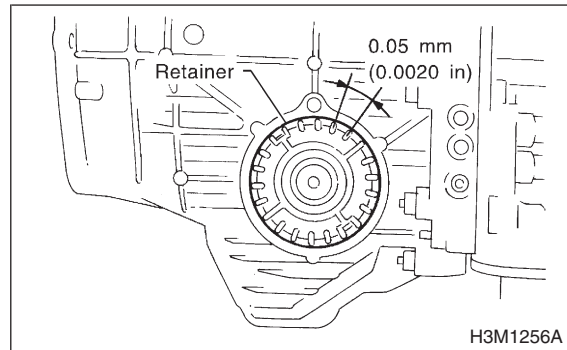

7) Turn the drive pinion several rotations with ST1 and check to see if the backlash is within the standard value with ST2, ST3, ST4 and ST5.

NOTE:

After confirming that the backlash is correct, check the tooth contact.

ST1 499787700 WRENCH
ST2 498247001 MAGNET BASE
ST3 498247100 DIAL GAUGE
ST4 499787500 ADAPTER WRENCH
ST5 498255400 PLATE

Backlash:

0.13 — 0.18 mm (0.0051 — 0.0071 in)

