

# PLANETARY GEAR AND LOW CLUTCH

Automatic Transmission

## 20. Planetary Gear and Low Clutch

S510212

### A: REMOVAL

S510212A18

1) Extract the torque converter clutch assembly.

NOTE:

- Extract the torque converter clutch horizontally. Be careful not to scratch the bushing inside the oil pump shaft.
- Note that oil pump shaft also comes out.

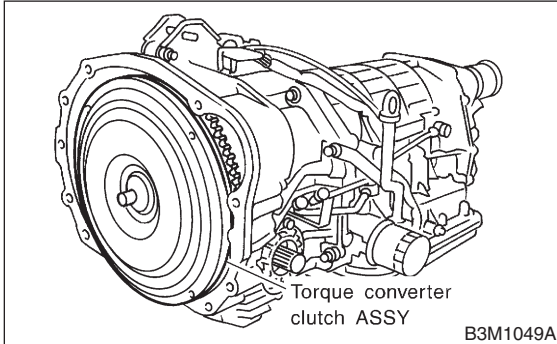

2) Remove the input shaft.

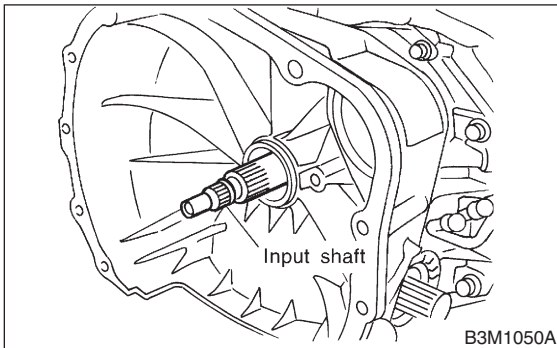

3) Disconnect transmission harness connector from stay.

NOTE:

Lift-up lever behind the connector and disconnect from stay.

- 4) Disconnect inhibitor switch connector from stay.
- 5) Disconnect the air breather hose.
- 6) Remove the oil charger pipe, and remove the O-ring from the flange face. Attach the O-ring to the pipe. <Ref. to AT-24 REMOVAL, Oil Charger Pipe.>
- 7) Remove the oil cooler inlet and outlet pipes. <Ref. to AT-25 REMOVAL, Oil Cooler Pipes.>

8) Separation of torque converter clutch case and transmission case sections

CAUTION:

- Be careful not to damage the oil seal and bushing inside the torque converter clutch case by the oil pump cover.
- Be careful not to lose the rubber seal.

NOTE:

Separate these cases while tapping lightly on the housing.

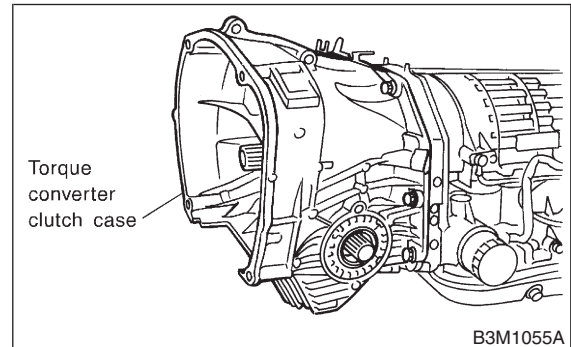

9) Remove the oil pump housing.

CAUTION:

Be careful not to lose the total end play adjusting thrust washer.

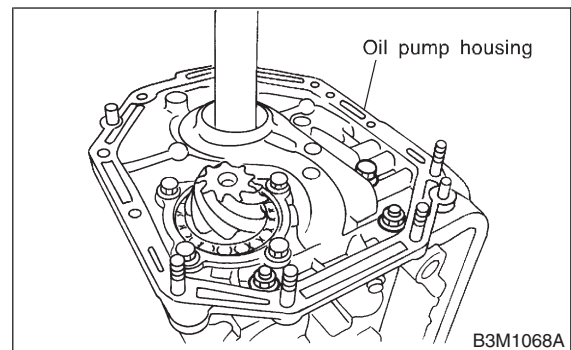

10) Remove 2-4 brake seal.

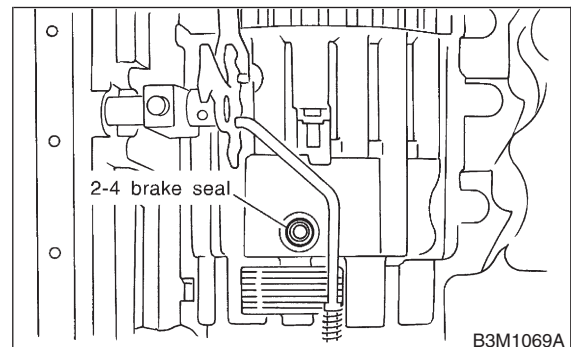

11) Take out the high clutch and reverse clutch assembly. <Ref. to AT-74 REMOVAL, High Clutch and Reverse Clutch.>

# PLANETARY GEAR AND LOW CLUTCH

Automatic Transmission

12) Take out the front sun gear and the thrust bearing.

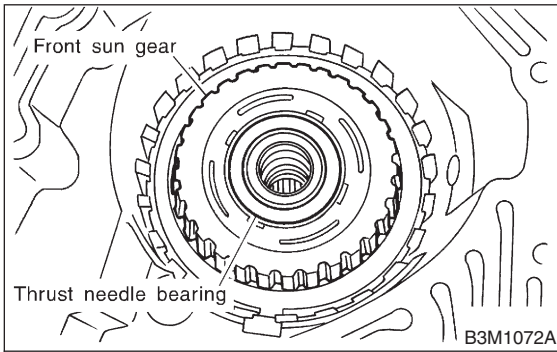

13) Pull out leaf spring.

### CAUTION:

Be careful not to bend leaf spring during removal.

### NOTE:

Remove it while pressing down on lower leaf spring.

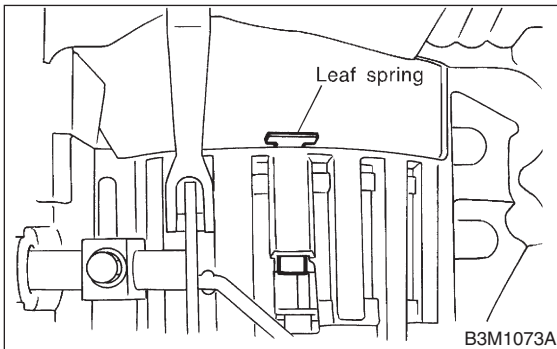

14) Remove snap ring and thrust needle bearing.

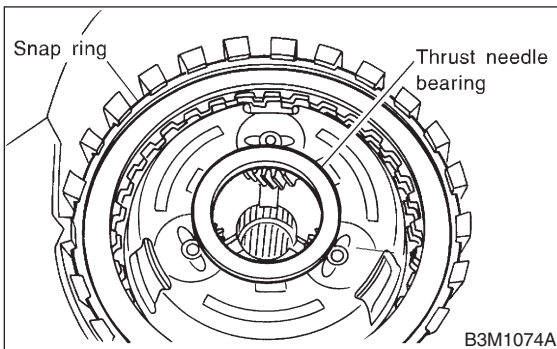

15) Take out retaining plate, drive plate and driven plate of 2-4 brake.

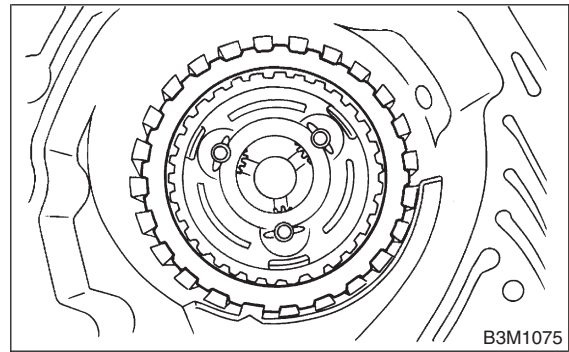

16) Take out the thrust needle bearing, planetary gear assembly and the low clutch assembly.

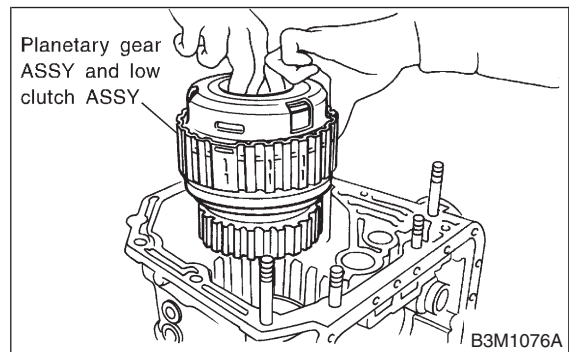

## B: INSTALLATION S510212A11

1) Install planetary gear and low clutch assembly to transmission case.

Install carefully while rotating the low clutch and planetary gear assembly slowly paying special attention not to damage the seal ring.

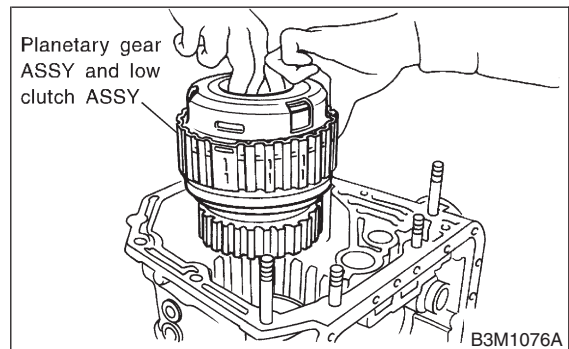

2) Install the 2-4 brake. <Ref. to AT-90 INSTALLATION, 2-4 Brake.>

# PLANETARY GEAR AND LOW CLUTCH

## Automatic Transmission

3) Install leaf spring of 2-4 brake.

**NOTE:**

Be careful not to mistake the location of the leaf spring to be inserted.

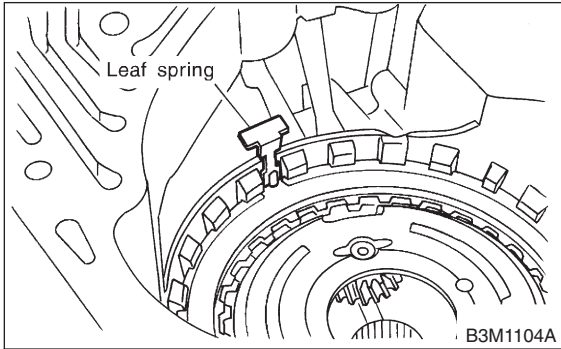

4) Install thrust needle bearing.

**NOTE:**

Install thrust needle bearing in the correct direction.

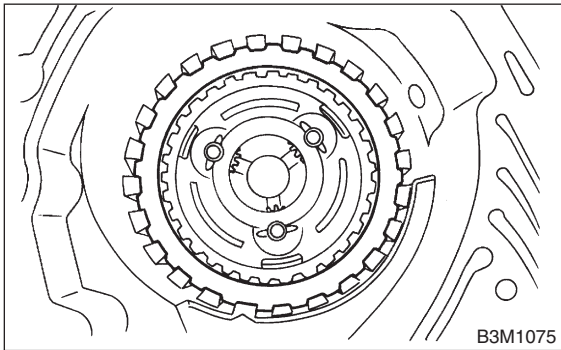

5) Install front sun gear and thrust needle bearing.

<Ref. to AT-90 INSTALLATION, 2-4 Brake.>

6) Install the high clutch assembly.

**NOTE:**

Correctly engage the high clutch hub and clutch splines.

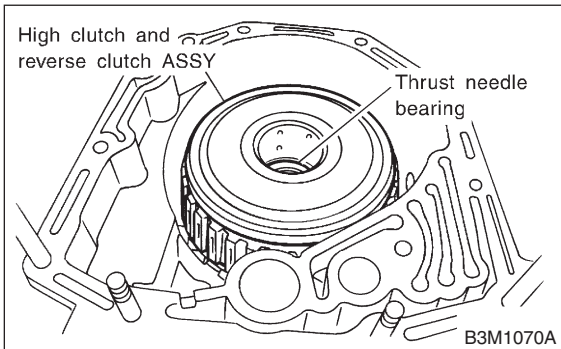

7) Install the high clutch hub and thrust needle bearing.

Attach the thrust needle bearing to the hub with vaseline and install the hub by correctly engaging the splines of the front planetary carrier.

**NOTE:**

Install thrust needle bearing in the correct direction.

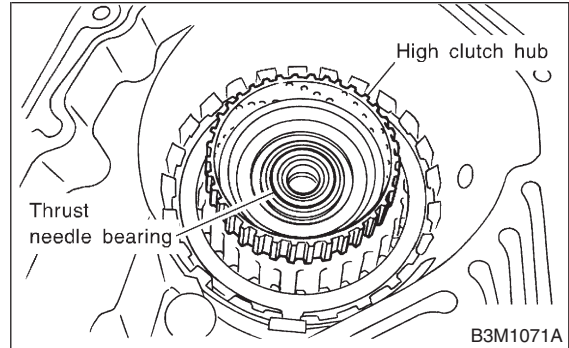

8) Adjust total end play. <Ref. to AT-79 ADJUSTMENT, High Clutch and Reverse Clutch.>

9) Remove four seal rings.

**CAUTION:**

Be careful not to damage O-ring.

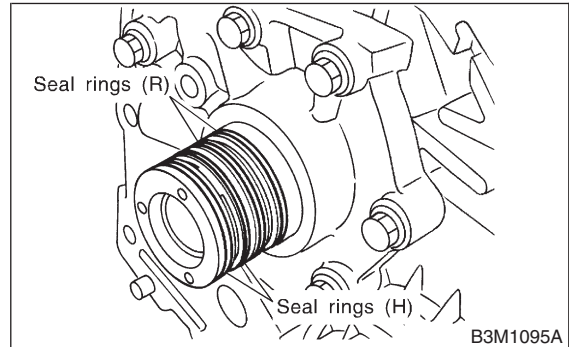

10) Remove the oil pump cover.

**NOTE:**

Lightly tap the end of the stator shaft to remove the cover.

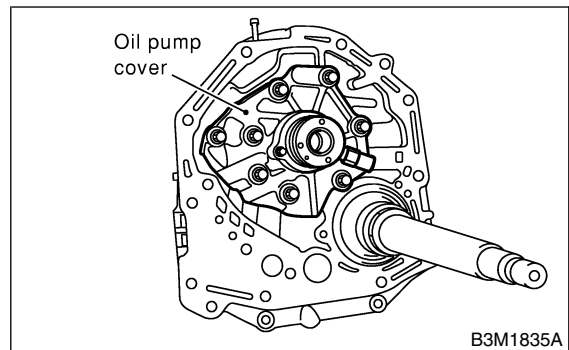

11) Remove the drive pinion assembly.

12) Install air breather hose.

- 13) Insert inhibitor switch and transmission connector into stay.
- 14) Install oil cooler pipes. <Ref. to AT-25 INSTALLATION, Oil Cooler Pipes.>
- 15) Install the oil charge pipe with O-ring. <Ref. to AT-24 INSTALLATION, Oil Charger Pipe.>
- 16) Insert the input shaft while turning lightly by hand.

**CAUTION:**  
Be careful not to damage the bushing.

**Normal protrusion A:**  
50 — 55 mm (1.97 — 2.17 in)

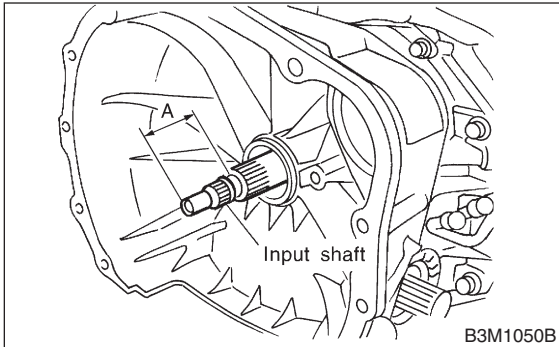

- 17) Install the torque converter clutch assembly. <Ref. to AT-30 INSTALLATION, Torque Converter Clutch Assembly.>

## C: DISASSEMBLY S510212A06

- 1) Remove snap ring from the low clutch drum.

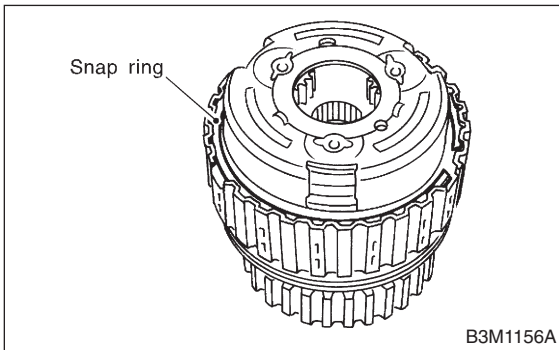

- 2) Take out front planetary carrier and thrust needle bearing from low clutch drum.

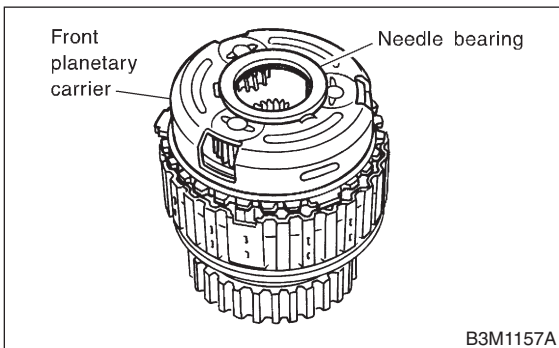

- 3) Take out rear sun gear.

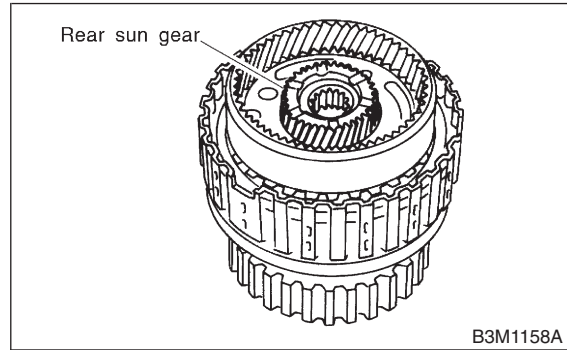

- 4) Take out rear planetary carrier, washer and thrust needle bearing.

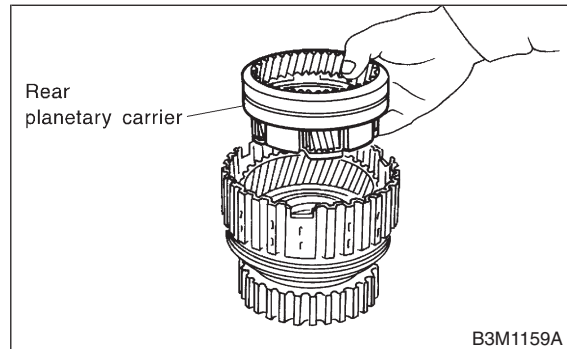

- 5) Take out rear internal gear.

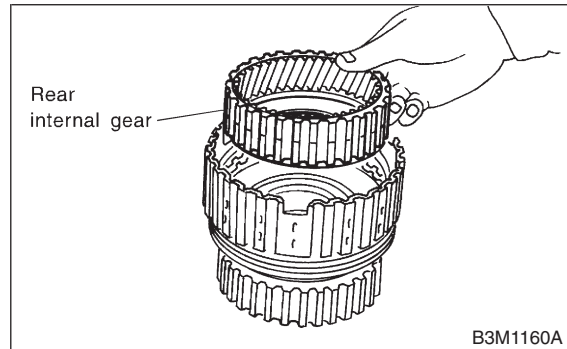

- 6) Remove the snap ring from the low clutch drum.

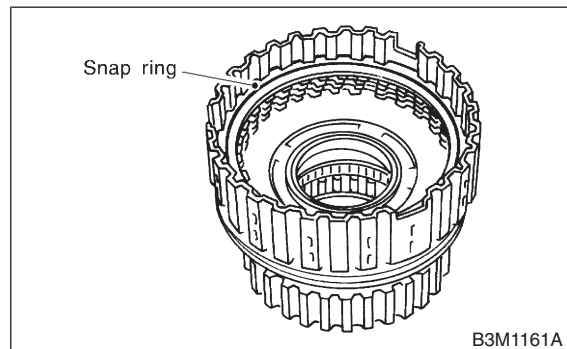

# PLANETARY GEAR AND LOW CLUTCH

Automatic Transmission

7) Compress the spring retainer, and remove the snap ring from the low clutch drum, by using ST1 and ST2.

ST1 498627100 SEAT  
ST2 398673600 COMPRESSOR

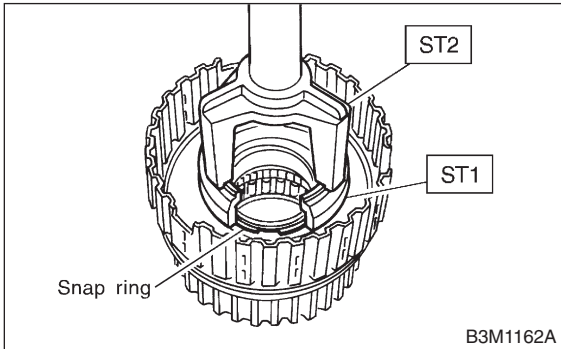

8) Install the one-way clutch inner race to the low clutch drum, and apply compressed air to remove the low clutch piston.

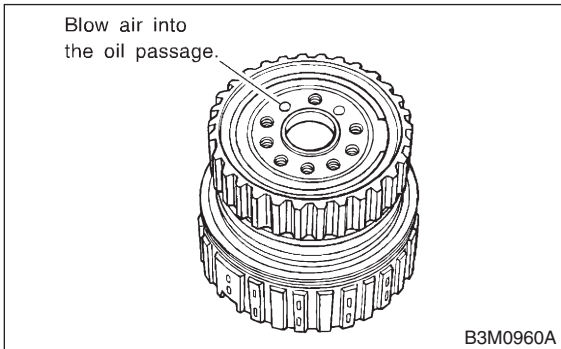

9) Remove the one-way clutch inner race.

10) Remove the one-way clutch after taking out the snap ring.

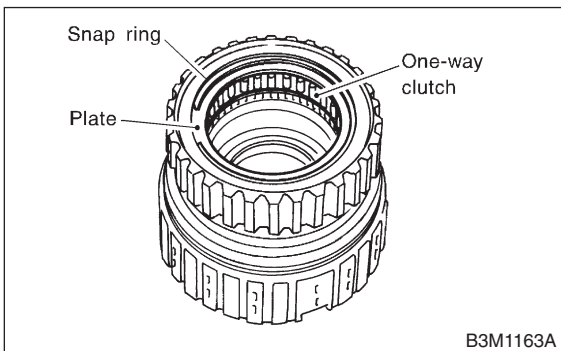

11) Remove the needle bearing after taking out the snap ring.

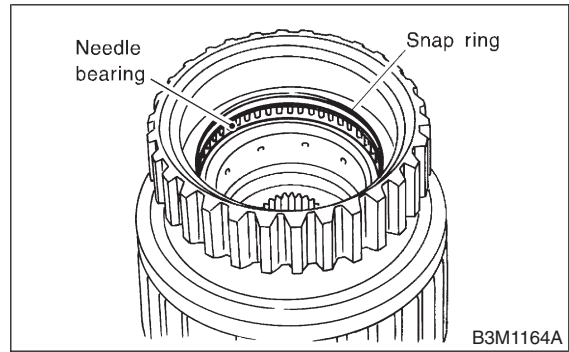

## D: ASSEMBLY S510212A02

- 1) Install lathe cut seal ring to low clutch piston.
- 2) Fit the low clutch piston to the low clutch drum.

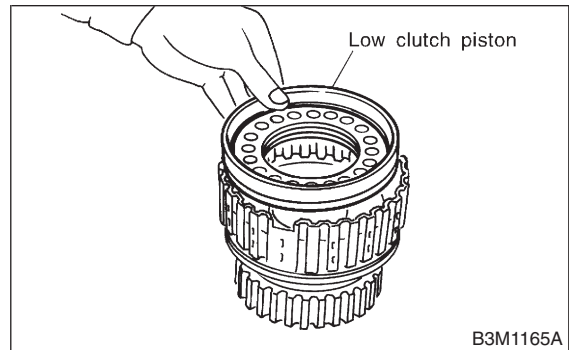

- 3) Install spring retainer to low clutch piston.

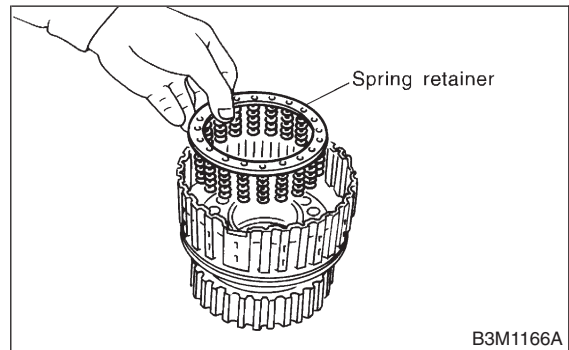

# PLANETARY GEAR AND LOW CLUTCH

Automatic Transmission

- 4) Install ST to low clutch drum.  
 ST 498437100 LOW CLUTCH PISTON GUIDE

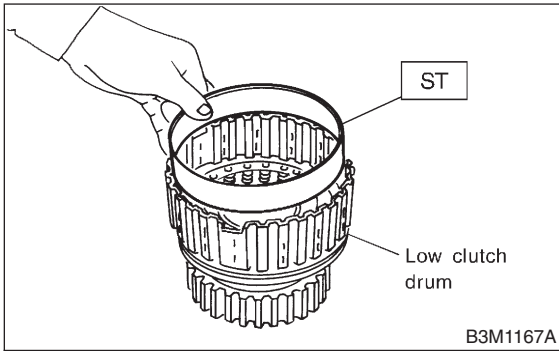

- 5) Set the cover on the piston with a press using ST1 and ST2, and attach the snap ring.

**CAUTION:**  
 Be careful not to fold cover seal during installation.

**NOTE:**  
 After installing snap ring, remove ST1, ST2 and ST3.

- ST1 498627100 SEAT  
 ST2 398673600 COMPRESSOR  
 ST3 498437100 LOW CLUTCH PISTON GUIDE

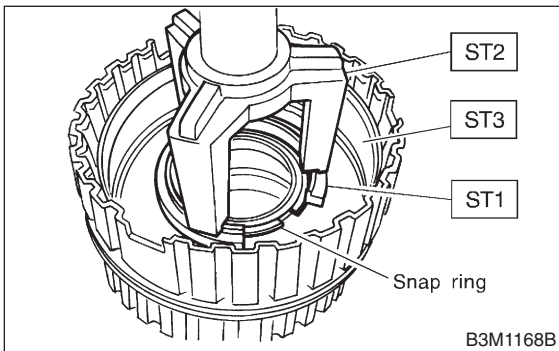

- 6) Install the dish plate, driven plates, drive plates, and retaining plate, and secure with the snap ring.

**NOTE:**  
 Pay attention to the orientation of the dish plate.

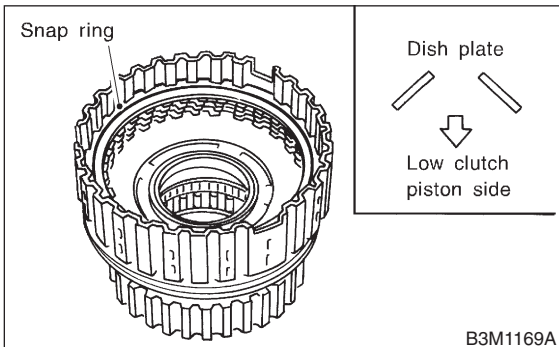

- 7) Check the low clutch for operation.  
 Set the one-way clutch inner race, and apply compressed air for checking.

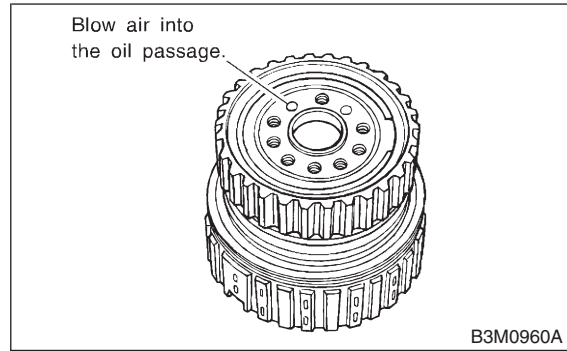

- 8) Checking low clutch clearance  
 Measure the gap between the retaining plate and the operation of the low clutch.

**NOTE:**  
 Before measuring clearance, place the same thickness of shim on both sides to prevent retaining plate from tilting.  
 If the clearance is out of the specified range, select a proper retaining plate so that the standard clearance can be obtained.

**Standard value:**  
 0.7 — 1.1 mm (0.028 — 0.043 in)

**Allowable limit:**  
 1.6 mm (0.063 in)

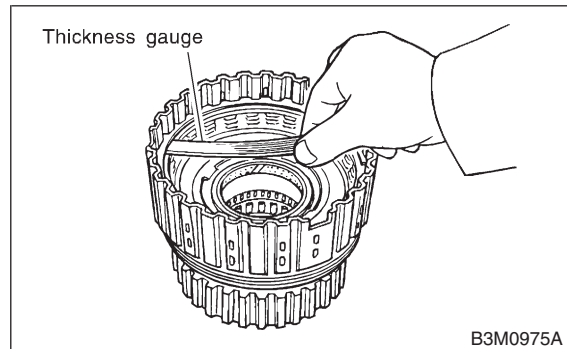

Available retaining plates	
Part No.	Thickness mm (in)
31567AA830	3.8 (0.150)
31567AA840	4.0 (0.157)
31567AA850	4.2 (0.165)
31567AA860	4.4 (0.173)
31567AA870	4.6 (0.181)

# PLANETARY GEAR AND LOW CLUTCH

Automatic Transmission

9) Install washer to rear internal gear.

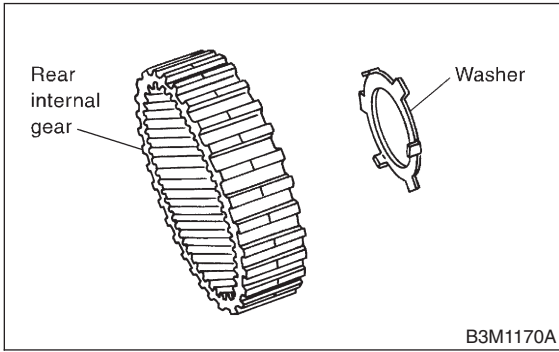

10) Install rear internal gear.

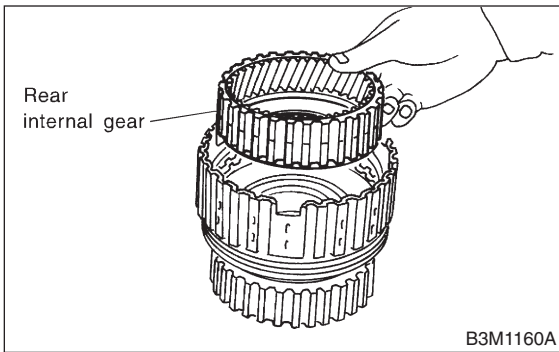

11) Install thrust needle bearing.

NOTE:  
Install thrust needle bearing in the correct direction.

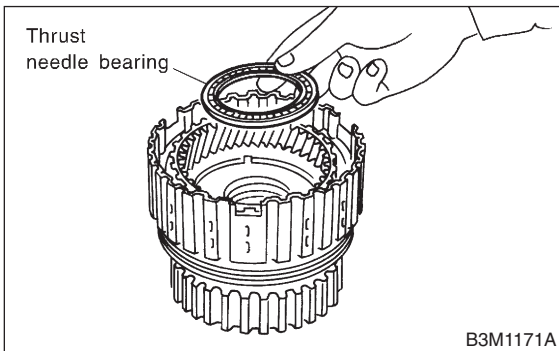

12) Install washer to rear planetary carrier.

NOTE:  
Make sure washer tooth is inserted into hole on planetary carrier.

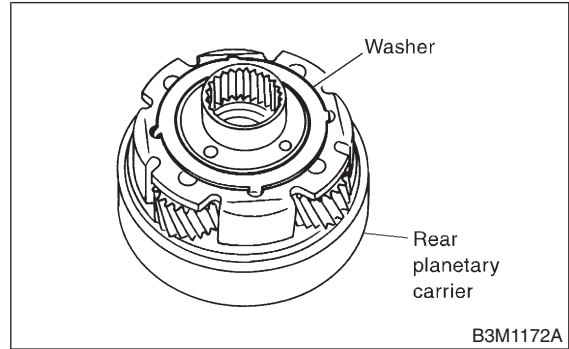

13) Install rear planetary carrier to low clutch drum.

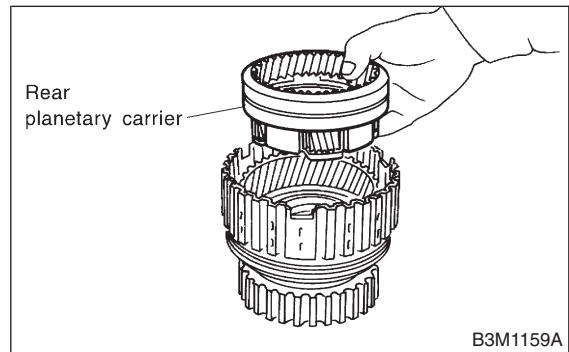

14) Install thrust needle bearing to rear planetary carrier.

NOTE:  
Install thrust needle bearing in the correct direction.

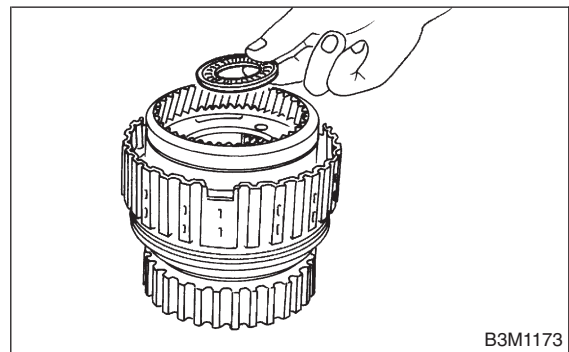

15) Install rear sun gear.

**NOTE:**

Pay attention to the orientation of the rear sun gear.

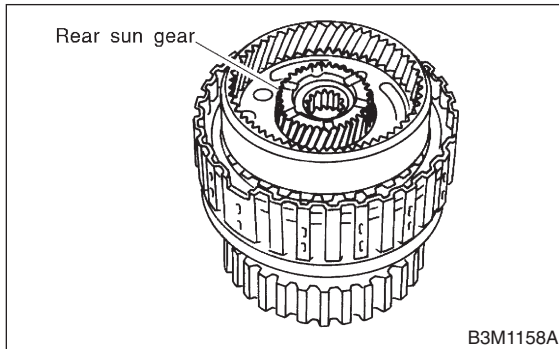

16) Install thrust needle bearing to front planetary carrier.

**NOTE:**

Pay attention to the orientation of the thrust needle bearing.

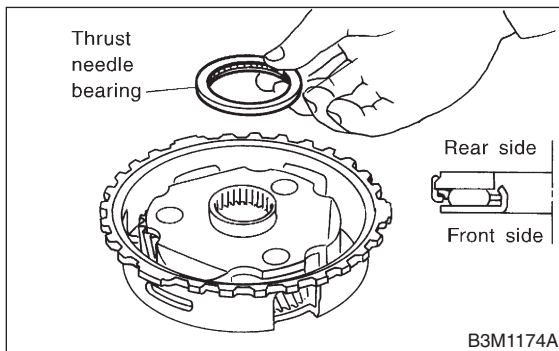

17) Install front planetary carrier to low clutch drum.

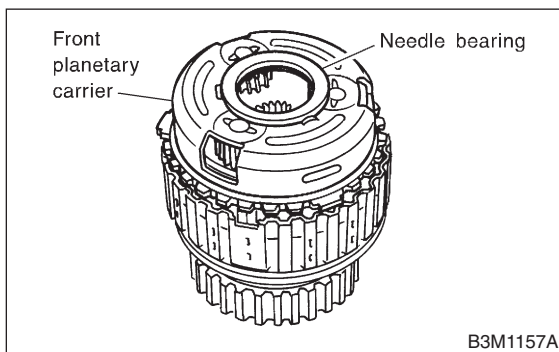

18) Install snap ring to low clutch drum.

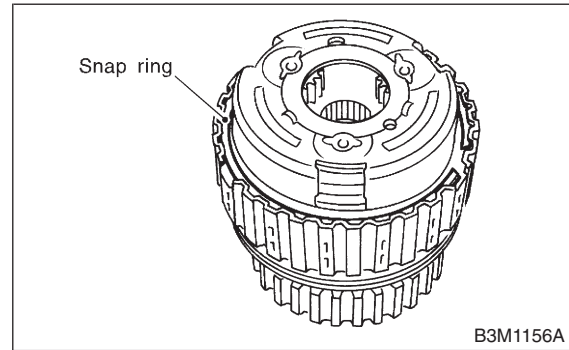

19) Install the needle bearing, and secure with the snap ring.

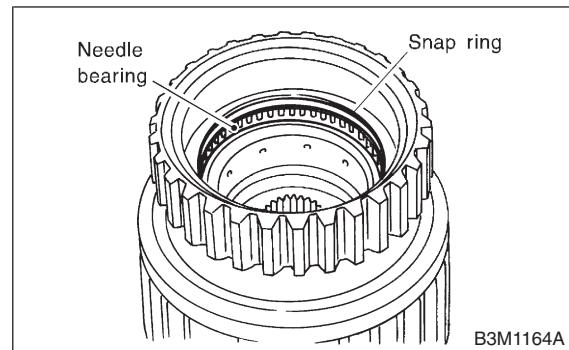

20) Install the one-way clutch, one-way clutch inner race and plate, and secure with the snap ring.

**NOTE:**

Set the inner race. Make sure that the forward clutch is free in the clockwise direction and locked in the counterclockwise direction, as viewed from the front of the vehicle.

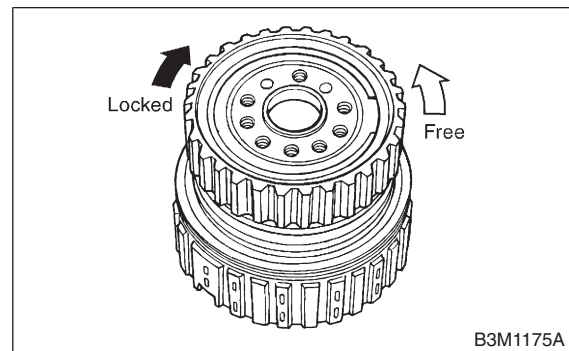

**E: INSPECTION** SS10212A10

- Drive plate facing for wear and damage
- Snap ring for wear, return spring for breakage or setting, and spring retainer for deformation
- Lip seal and lathe cut seal ring for damage
- Piston check ball for operation
- Measure the total end play and adjust to within specifications.