

14. Torque Converter Clutch Case

SS10206

A: REMOVAL

SS10206A18

1) Extract the torque converter clutch assembly.
<Ref. to AT-30 REMOVAL, Troque Converter Clutch Assembly.>

NOTE:

- Extract the torque converter clutch horizontally. Be careful not to scratch the bushing inside the oil pump shaft.
- Note that oil pump shaft also comes out.

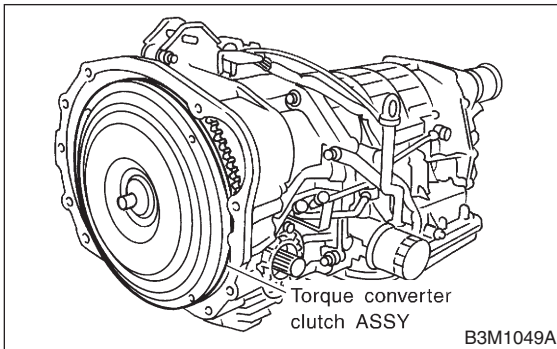

2) Remove the input shaft.

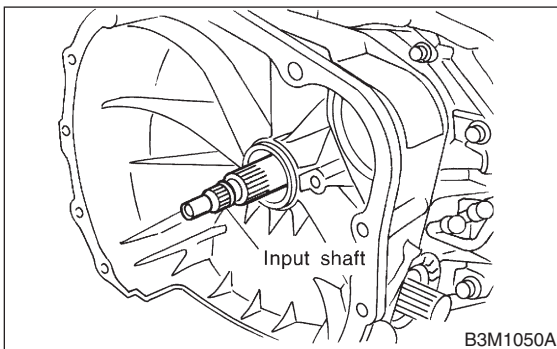

3) Remove pitching stopper bracket.

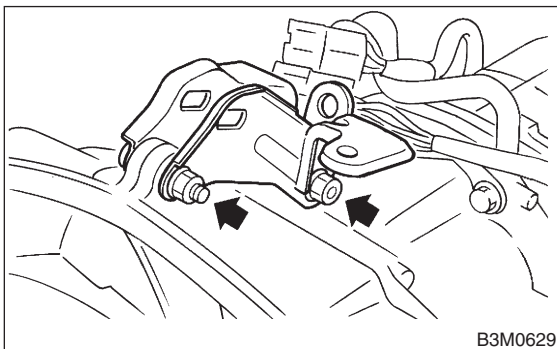

4) Disconnect transmission harness connector from stay.

NOTE:

Lift-up lever behind the connector and disconnect it from stay.

- 5) Disconnect inhibitor switch connector from stay.
- 6) Disconnect the air breather hose. <Ref. to xx.>
- 7) Remove the oil charger pipe, and remove the O-ring from the flange face. Attach the O-ring to the pipe. <Ref. to AT-24 REMOVAL, Oil Charger Pipe.>
- 8) Remove the oil cooler inlet and outlet pipes. <Ref. to AT-25 REMOVAL, Oil Cooler Pipes.>
- 9) Separation of torque converter clutch case and transmission case sections

CAUTION:

- Be careful not to damage the oil seal and bushing inside the torque converter clutch case by the oil pump cover.
- Be careful not to lose the rubber seal.

NOTE:

Separate these cases while tapping lightly on the housing.

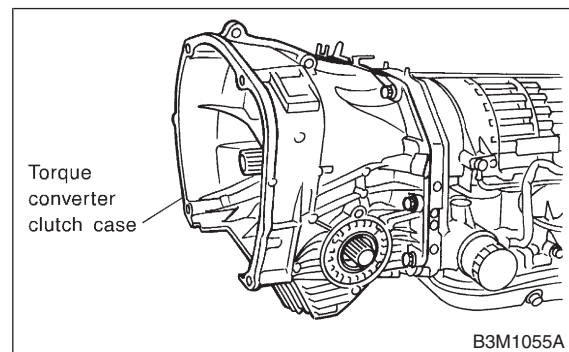

10) Wrap the axle shaft serration with vinyl tape.

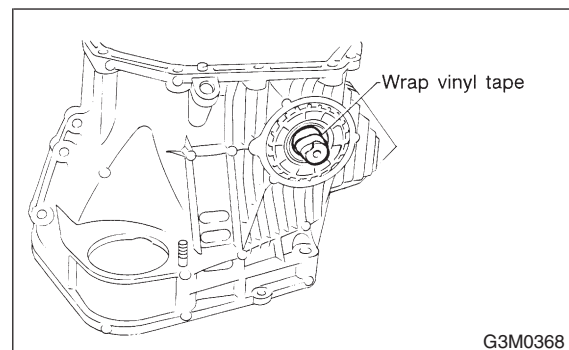

11) Remove the differential side retainer with ST.

CAUTION:

Hold the differential case assembly by hand to avoid damaging retainer mounting hole of the torque converter clutch case and speedometer gears.

ST 499787000 WRENCH ASSY

TORQUE CONVERTER CLUTCH CASE

Automatic Transmission

12) Extract the axle shaft with ST1 and ST2.

CAUTION:

Do not reuse the circlip.

ST1 499095500 REMOVER
ST2 499247300 INSTALLER

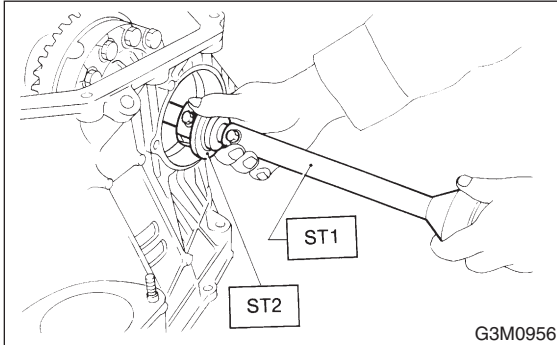

13) Remove the differential assembly.

CAUTION:

- Remove the seal pipe if it is attached. (Reusing is not allowed.)
- Be careful not to damage the retainer mounting hole of the torque converter clutch case.

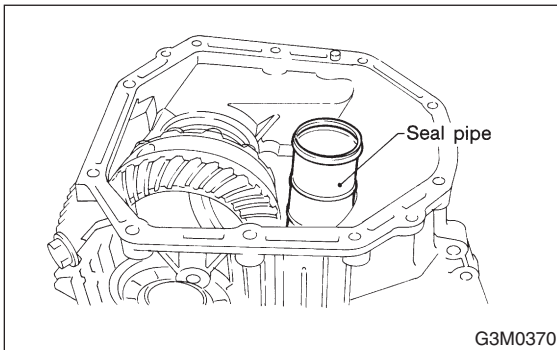

14) Remove the oil seal from torque converter clutch case.

B: INSTALLATION

S510206A11

1) Check the appearance of each component and clean.

CAUTION:

Make sure each part is free of harmful cuts, damage and other faults.

2) Force-fit the oil seal to the torque converter clutch case with ST.

ST 398437700 DRIFT

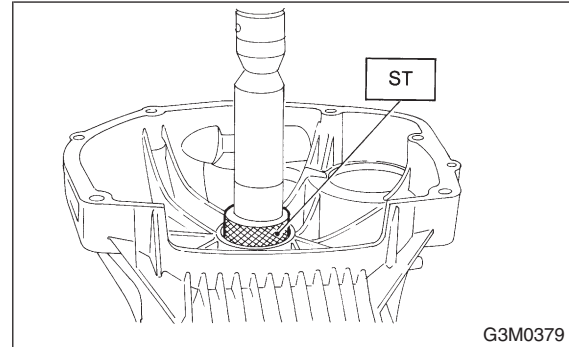

3) Install the differential assembly to the case, paying special attention not to damage the inside of the case (particularly, the differential side retainer contact surface).

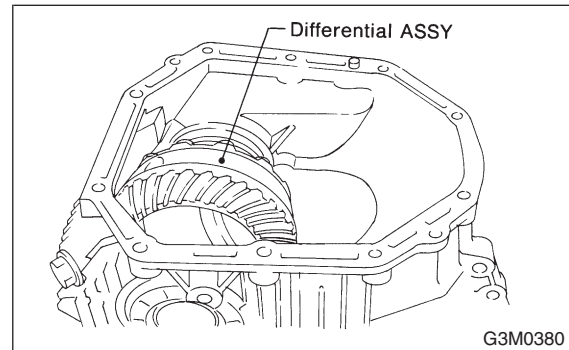

4) Install the circlip to the axle shaft, insert the shaft into the differential assembly, and tap it into position with a plastic hammer.

CAUTION:

- If no play is felt, check whether the shaft is fully inserted. If shaft insertion is correct, replace the axle shaft.
- Be sure to use a new circlip.

Thrust play:

0.3 — 0.5 mm (0.012 — 0.020 in)

5) Wrap vinyl tape around the splined portion of the axle shaft.

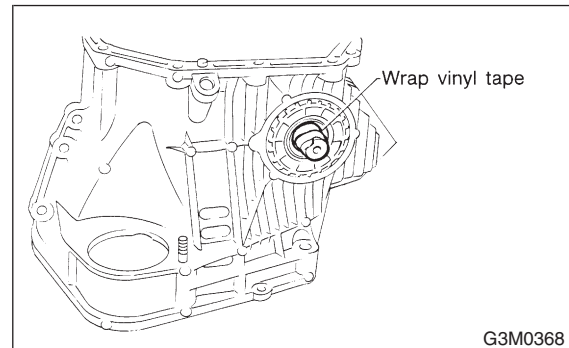

TORQUE CONVERTER CLUTCH CASE

Automatic Transmission

6) Install the oil seal and outer race (taper roller bearing) to the differential side retainer. Then screw in the retainer and the O-ring after coating the threads with oil.

CAUTION:

- Pay attention not to damage the oil seal lips.
- Do not confuse the RH and LH oil seals.
- Keep the O-ring removed from the retainer.

7) Using the ST, install the left and right side retainers. <Ref. to AT-66 ADJUSTMENT, Front Differential.>

ST 499787000 WRENCH ASSY

8) Install the seal pipe to the torque converter clutch case.

CAUTION:

Be sure to use a new seal pipe.

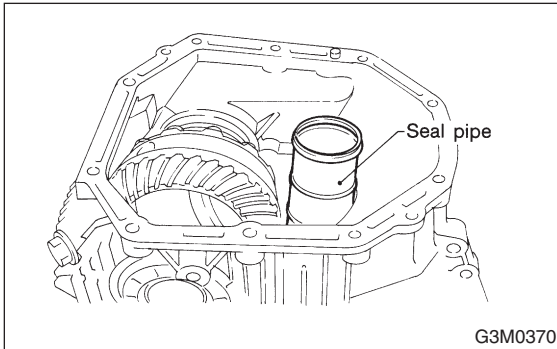

9) Install the rubber seal to the torque converter clutch case.

CAUTION:

Be careful not to lose the rubber seal.

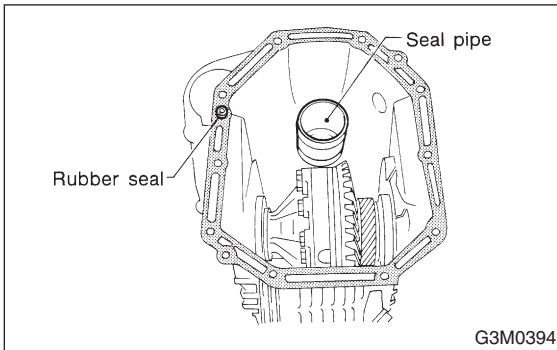

10) Apply proper amount of liquid gasket (THREE BOND Part No. 1215) to the entire torque converter clutch case mating surface.

NOTE:

Make sure that the rubber seal and seal pipe are fitted in position.

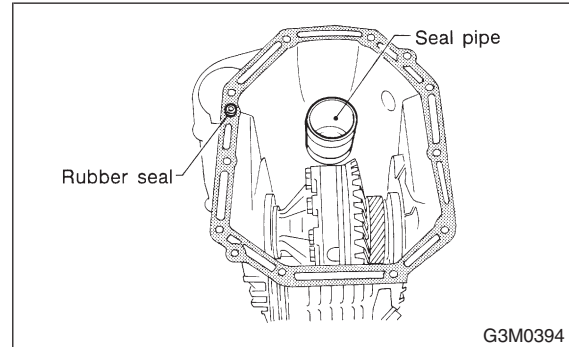

11) Install the torque converter clutch case assembly to the transmission case assembly, and secure with six bolts and four nuts.

CAUTION:

When installing, be careful not to damage the torque converter clutch case bushing and oil seal.

Tightening torque:

41 N·m (4.2 kgf·m, 30.4 ft·lb)

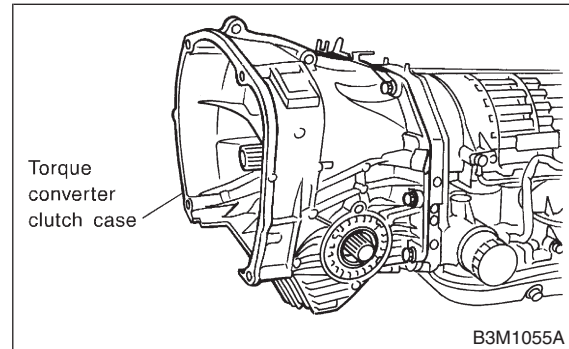

12) Install air breather hose. <Ref. to AT-23 INSTALLATION, Air Breather Hose.>

13) Insert inhibitor switch and transmission connector into stay. <Ref. to AT-32 INSTALLATION, Inhibitor Switch.>

14) Install the oil cooler pipes. <Ref. to AT-25 INSTALLATION, Oil Cooler Pipes.>

15) Install the oil charge pipe with O-ring. <Ref. to AT-24 INSTALLATION, Oil Charger Pipe.>

TORQUE CONVERTER CLUTCH CASE

Automatic Transmission

16) Install the pitching stopper bracket.

Tightening torque:

41 N·m (4.2 kgf-m, 30.4 ft-lb)

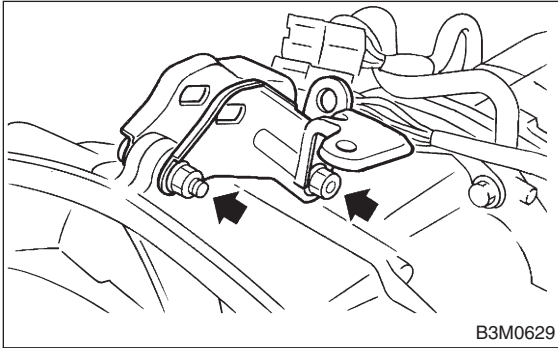

17) Insert the input shaft while turning lightly by hand.

CAUTION:

Be careful not to damage the bushing.

Normal protrusion A:

50 — 55 mm (1.97 — 2.17 in)

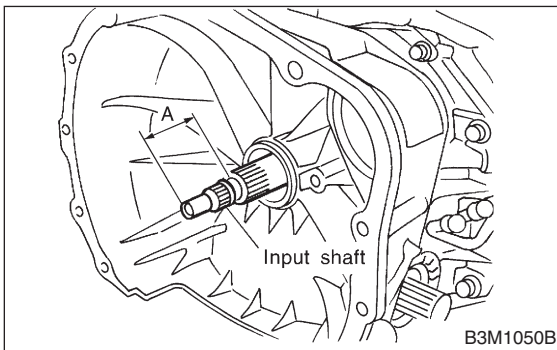

18) Install the torque converter clutch assembly.
<Ref. to AT-30 INSTALLATION, Torque Converter Assembly.>

C: INSPECTION S510206A10

Measure the backlash and adjust to within specifications. <Ref. to AT-30 INSTALLATION, Torque Converter Clutch Assembly.>