

## 1. Pre-delivery Inspection SA09719

### A: GENERAL SA09719G23

The purposes of the pre-delivery inspection (PDI) are as follows.

- Remove the additional parts used for ensuring the vehicle quality during transportation and restore the vehicle to its normal state.
- Check if the vehicle before delivery is in a normal state.
- Check for any damage or missing parts that may have taken place during transportation or storage.
- Make sure to provide a complete vehicle to the customer.

Because of the above reasons, all dealerships must always carry out the PDIs before delivering a vehicle.

In addition, all franchised shops and PDI centers must check the status of every vehicle received to identify who is responsible for any possible defects.

## B: PDI PROCEDURE SA09719G50

Follow the procedures shown in the table below.

### Static Checks Just After Vehicle Receipt

Step	Check point
1. Appearance check	(1) If the vehicle is covered with protective coating, visually check the vehicle body for damage and dents. If the protective coating has been removed, visually check the body paints for small areas of damage or stains. (2) Visually check the glass and light lenses for any damage and cracks or excessive gaps to the body sheet metal. (3) Visually check the plated parts for any damage.
2. Tire check	(1) Check the tires for damage, abnormal conditions, and dents on the wheels. (2) Check the tire air pressure.
3. Check the doors for lock/unlock and open/close operations.	(1) Using the key, check if the door can be locked and unlocked normally. (2) Open and close the all doors to see that there are no abnormal conditions.
4. Power window operation check	(1) Check the power window for correct operations.
5. Operation check of trunk lock release lever	(1) Operate the trunk lock release lever to check that the trunk opens normally.
6. Operation check of rear gate lock release lever	(1) Operate the rear gate lock release lever to check that the rear gate is unlocked normally.
7. Operation check of fuel lid opener lock release lever	(1) Operate the fuel lid opener to check that the fuel lid is unlocked normally.
8. Accessory check	Check the following accessories are provided: <ul style="list-style-type: none"> <li>● Owner's manual</li> <li>● Warranty booklet</li> <li>● Service booklet</li> <li>● Spare key</li> <li>● Jack</li> <li>● Tool set</li> <li>● Spare tire</li> </ul>
9. Operation check of hood lock release system	(1) Operate the hood lock release lever to check that the hood opens normally.
10. Fuse installation	(1) If the vehicle is about to be delivered to the customer, attach a room lamp fuse.
11. Connection of air conditioner harness	(1) If the vehicle is about to be delivered to the customer, connect the air conditioner harness.
12. Battery	(1) Check the battery for any abnormal conditions such as rust and trace of battery fluid leaks.
13. Brake fluid	(1) Check the fluid amount.
14. Engine oil	(1) Check the oil amount.
15. Transmission fluid	(1) Check the fluid amount. (2) For AT, check the front differential oil.
16. AT front differential oil	(1) Check the AT front differential oil amount.
17. Coolant	(1) Check the coolant amount.
18. Clutch fluid	(1) Check the clutch fluid amount.
19. Window washer fluid	(1) Check the window washer fluid amount.
20. Hood latch check	(1) Check that the hood is closed and latched securely.
21. Seat	(1) Check the seat surfaces for smears or dirt. (2) Check the seat installation conditions and functionality.
22. Seat belt	(1) Check the seat belt installation conditions and functionality.
23. Wheel alignment	(1) Check that the wheel alignments are properly adjusted.

# PRE-DELIVERY INSPECTION

Pre-delivery Inspection

## Checks with the Engine Running

Step	Check point
1. Test mode connector	(1) Disconnect the test mode connector.
2. Operation check of shift lock system, key interlock, and starter interlock	(1) For a MT vehicle, check the starter interlock system operations. (2) For an AT vehicle, check the shift lock and key interlock system operations.
3. Starting condition	(1) Start the engine and check that the engine starts smoothly.
4. Exhaust system	(1) Check that the exhaust noise is normal and no leaks are found.
5. Indicator light	(1) Check that all the indicator lights operate normally.
6. Clock	(1) Check that the clock operate normally.
7. Radio	(1) Check that the radio system operates normally.
8. Cigarette lighter	(1) Check that the cigarette lighter operates normally.
9. Lighting system	(1) Check that the lighting systems operate normally.
10. Window washer	(1) Check that the window washer system operates normally.
11. Wiper	(1) Check that the wiper system operates normally.

## Dynamic Test with the Vehicle Running

Step	Check point
1. Brake test	(1) Check that the foot brake operates normally.
2. Parking brake	(1) Check that the parking brake operates normally.
3. AT shift control	(1) Check the AT shift patterns are correct.
4. Heater & ventilation	(1) Check that the heater & ventilation system operates normally.
5. Air conditioner	(1) Check that the air conditioner operates normally.
6. Cruise control	(1) Check that the cruise control system operates normally.

## Checks after Dynamic Test

Step	Check point
1. ATF level	(1) Check that the ATF level is normal.
2. Power steering fluid level	(1) Check that the power steering fluid level is normal.
3. Fluid leak check	(1) Check for fluid/oil leaks.
4. Water leak check	(1) Spray the vehicle with water and check for water leaks.
5. Appearance check 2	(1) Remove the protective coating (if any). (2) Check the body paints for damage and smears. (3) Check the plated parts for damage and rust.

## 1. APPEARANCE CHECK SA09719G5001

- If the vehicle is covered with protective coating, visually check the vehicle body for damage and dents.
- If there is no protective coating, check the body paints for small areas of damage or stains and repair as necessary.
- Check the window glass, door glass, and lights for any cracks or damage and repair or replace the parts as necessary.
- Check the plated parts, such as the grilles and door knobs, for damage or loss of gloss and repair or replace the parts as necessary.

## 2. TIRE CHECK SA09719G5002

- Check the tire outer faces for any damage.
- Check the tire air pressure by referring to the following table.

Tire size	Tire inflation pressure kPa (kg/cm <sup>2</sup> , psi)	
	Front	Rear
P195/60R15	220 (2.2, 32)	200 (2.0, 29)
P205/60R15	220 (2.2, 32)	200 (2.0, 29)
R205/55R16	220 (2.2, 32)	200 (2.0, 29)

## 3. CHECK THE DOOR OPERATIONS, LOCK/UNLOCK AND OPEN/CLOSE, AS FOLLOWS. SA09719G5003

Using the key, lock and unlock the door several times to check for normal operation. Open and close the door several times for smooth movement.

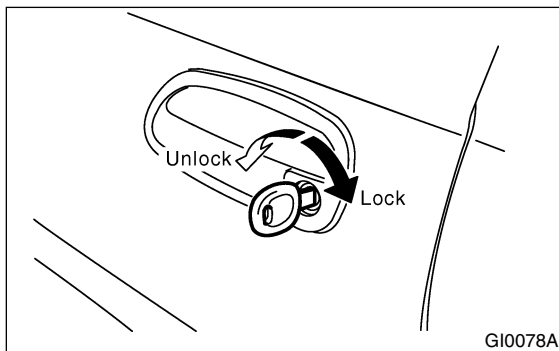

### ● Vehicles with manual door locks:

Sit in the driver seat, close the door completely, and move the lock lever to the lock position. Then, pull the inside door handle to ensure the door will not open.

### ● Vehicles with power door locks:

Sit in the driver seat, close the driver's door completely, and place the door lock knob (A) to the lock position. Then pull the all inside door handles (B) to ensure that the all doors will not open. For other doors, place the lock levers to the lock positions and then pull the inside door handles to ensure that the doors will not open.

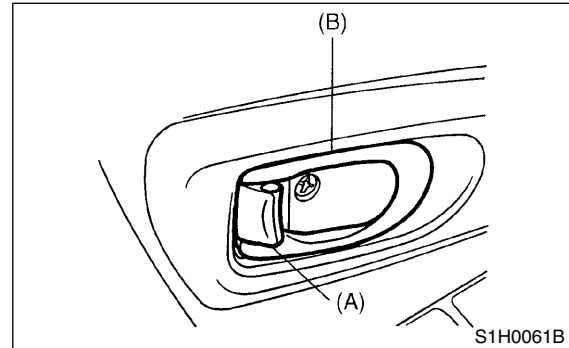

## 4. POWER WINDOW OPERATION CHECK SA09719G5004

SA09719G5004

Manipulate the power window switches one by one to check that each of the power windows goes up and down with no abnormal noises.

## 5. OPERATION CHECK OF TRUNK LOCK RELEASE LEVER SA09719G5005

Operate the trunk lock release lever and verify that the trunk lid opens.

## 6. OPERATION CHECK OF REAR GATE LOCK RELEASE LEVER SA09719G5006

Operate the rear gate lock release lever and verify that the rear gate is unlocked and opened smoothly.

## 7. OPERATION CHECK OF FUEL LID OPENER LOCK RELEASE LEVER SA09719G5007

Operate the fuel lid opener and verify that the fuel lid opens normally. Check that the filler cap is securely closed.

# PRE-DELIVERY INSPECTION

Pre-delivery Inspection

## 8. ACCESSORY CHECK SA09719G5008

Check that the following accessories are provided in the vehicle.

- Owner's manual
- Warranty booklet
- Service booklet
- Spare key
- Jack
- Tool set
- Spare tire

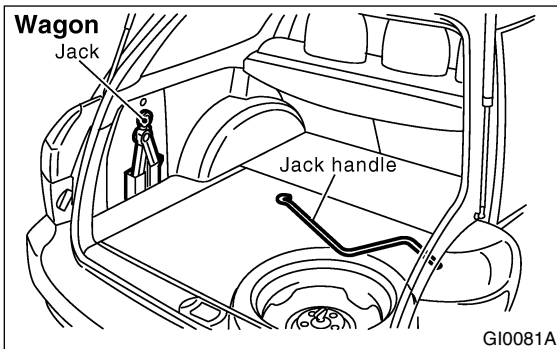
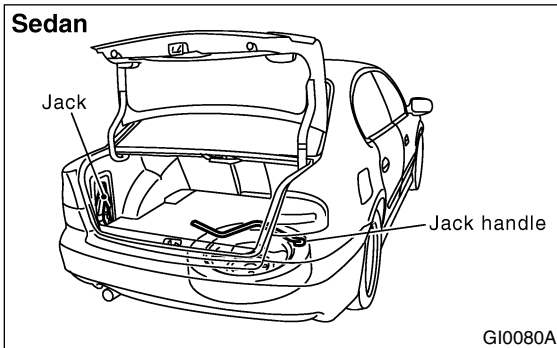

## 9. OPERATION CHECK OF HOOD LOCK RELEASE SYSTEM SA09719G5009

Unlatch and open the hood while checking that no abnormal conditions are found. Then, support the hood with the hood stay.

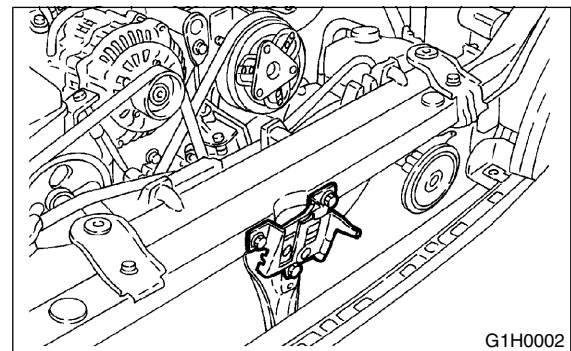
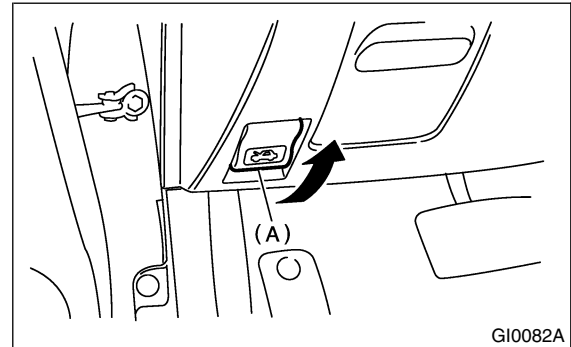

## 10. FUSE INSTALLATION SA09719G5010

A vehicle just delivered has no fuses for the room lamp circuit to prevent battery discharge. Attach a 15 A fuse as shown in the figure.

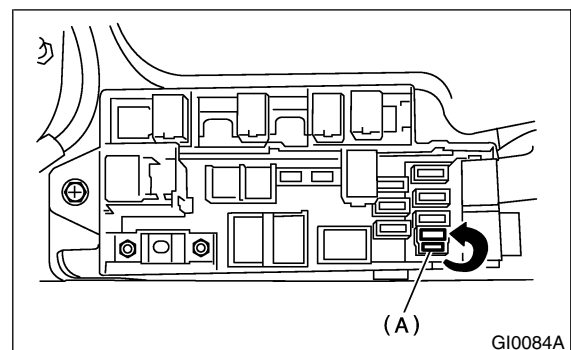

## 11. CONNECTION OF AIR CONDITIONER HARNESS SA09719G5011

A vehicle just delivered has its air conditioner harness disconnected to protect the air conditioner compressor. Connect the harness as shown in the figure.

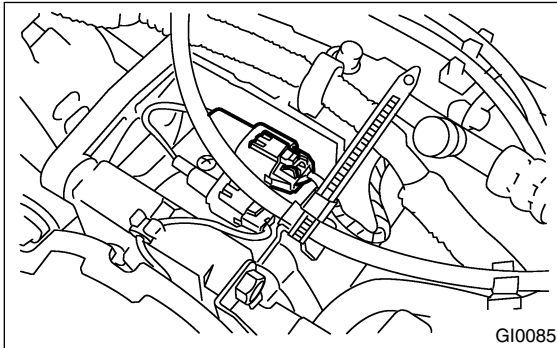

## 12. BATTERY SA09719G5012

Check the battery terminals to make sure that no rust or corrosions due to fluid leaks are found. Check that the battery tent is securely tightened.

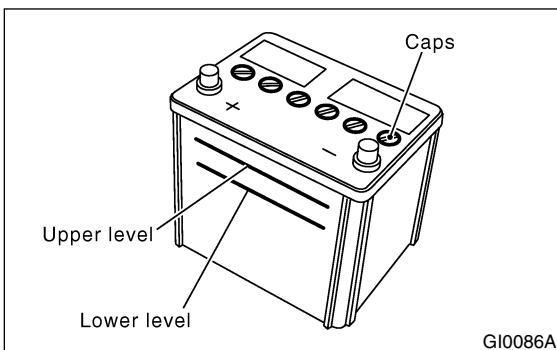

## 13. BRAKE FLUID SA09719G5013

Check the brake fluid amount. If the amount is insufficient, carry out a brake line test to identify brake fluid leaks and check the brake operation. After that, refill the brake fluid tank with the specified type of fluid.

## 14. ENGINE OIL SA09719G5014

Check the engine oil amount. If the amount is insufficient, check that no leaks are found. Then, add the necessary amount of the specified engine oil.

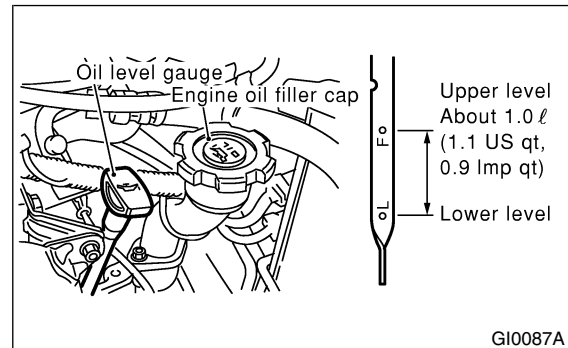

## 15. TRANSMISSION FLUID SA09719G5015

Check the transmission fluid amount. If the amount is insufficient, check that no leaks are found. Then, add the necessary amount of the specified fluid.

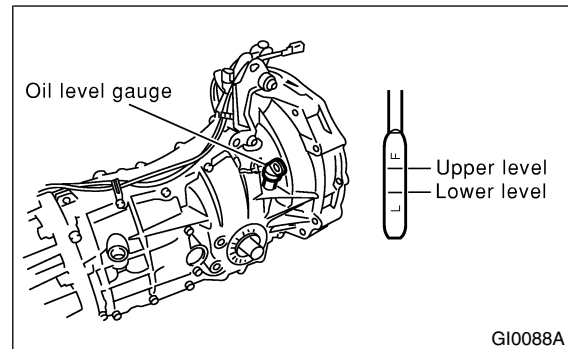

## 16. AT FRONT DIFFERENTIAL OIL SA09719G5016

Check the AT front differential oil amount. If the amount is insufficient, check that no leaks are found. Then, add the necessary amount of the specified AT front differential oil.

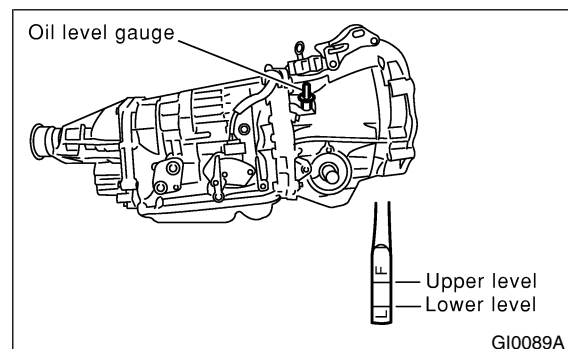

# PRE-DELIVERY INSPECTION

## Pre-delivery Inspection

### 17. COOLANT SA09719G5017

Check the coolant amount on the reservoir. If the amount is insufficient, check that no leaks are found. Then, add the necessary amount of coolant with the specified concentration.

### 18. CLUTCH FLUID SA09719G5018

Check the clutch fluid amount. If the amount is insufficient, check that no leaks are found. Then, add the necessary amount of the specified fluid.

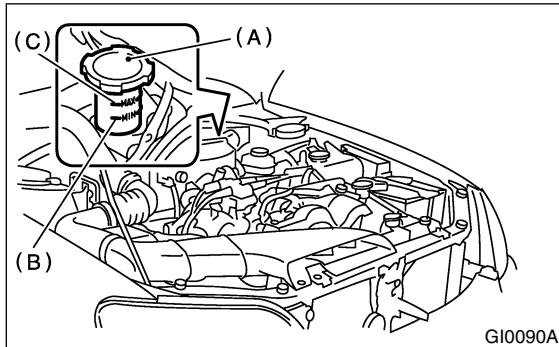

### 19. WINDOW WASHER FLUID SA09719G5019

Check the window washer fluid amount. If the amount is insufficient, check that no leaks are found. Then, add the necessary amount of washer fluid commercially available.

### 20. HOOD LATCH CHECK SA09719G5020

Retract the hood stay and close the hood. Check that the hood is securely latched.

### 21. SEAT SA09719G5023

Check that each seat provides full functionality in sliding and reclining. Check all available functions of the rear seat such as a trunk-through.

### 22. SEAT BELT SA09719G5024

Pull out the seat belt and then release it. Check that the belt webbing retracts smoothly.

### 23. WHEEL ALIGNMENT SA09719G5026

Check the wheel alignments. <Ref. to FS-6 Wheel Alignment.> and <Ref. to RS-7 Wheel Alignment.>

### 24. TEST MODE CONNECTOR SA09719G5027

Turn the ignition switch to ON and check that the check-engine light starts blinking. If the light blinks, return the ignition key to LOCK and disconnect the test mode connector. Then, turn the ignition key to ON again. If the check-engine light blinks at that time in spite of the disconnected test mode connector, carry out an engine diagnosis.

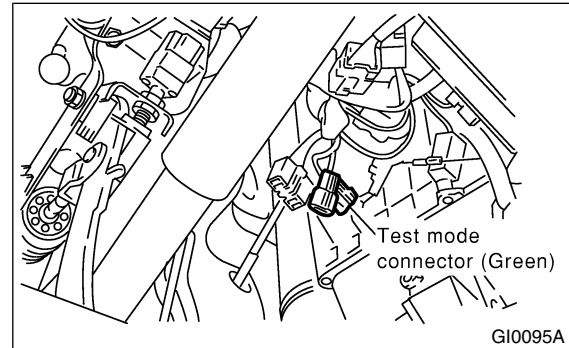

### 25. OPERATION CHECK OF SHIFT LOCK SYSTEM, KEY INTERLOCK, AND STARTER INTERLOCK SA09719G5028

- For a MT vehicle, check the starter interlock system operations.
- For an AT vehicle, check the shift lock and key interlock system operations.

### 26. STARTING CONDITION SA09719G5029

Start the engine and check that the engine starts smoothly. If any battery voltage problems are found, recharge or replace the battery. If any abnormal noises are observed, immediately stop the engine and check and repair the necessary components.

### 27. EXHAUST SYSTEM SA09719G5030

Listen to the exhaust noise to see if no abnormal noises are observed.

### 28. INDICATOR LIGHT SA09719G5031

Check that all the indicator lights are off.

### 29. CLOCK SA09719G5032

Check the clock for normal operations and enough accuracy.

### 30. RADIO SA09719G5033

Check the radio for full functionality and normal noise level. Also check the CD unit operations.

### 31. CIGARETTE LIGHTER SA09719G5034

Check that the cigarette lighter operations.

## 32. LIGHTING SYSTEM SA09719G5035

- Check the headlight operations.
- Check the brake light operations.
- Check the other lights for normal operations.

## 33. WINDOW WASHER SA09719G5036

Check that the window washer system injects washer fluid to the specified area of the windshield shown in the figure.

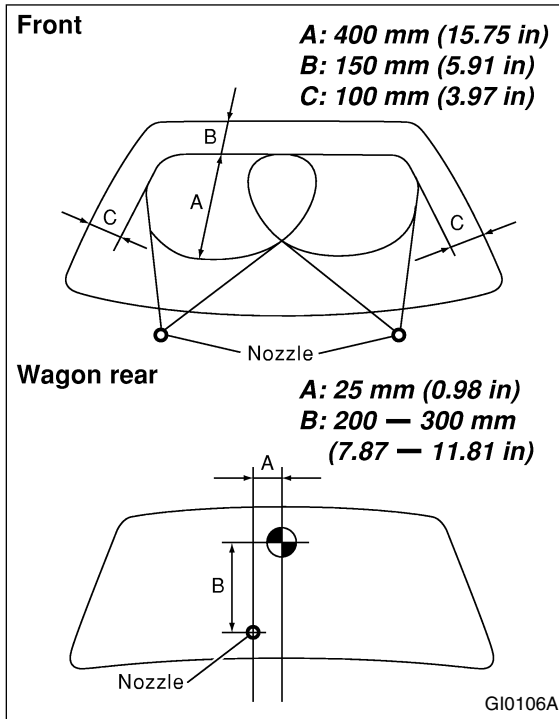

## 34. WIPER SA09719G5037

Check the front and rear wipers for normal operations.

## 35. BRAKE TEST SA09719G5038

Check the foot brake for normal operations.

## 36. PARKING BRAKE SA09719G5039

Check the parking brake for normal operations.

## 37. AT SHIFT CONTROL SA09719G5041

Set the AT select lever to each gear position while checking that the demanded gear position is correctly attained.

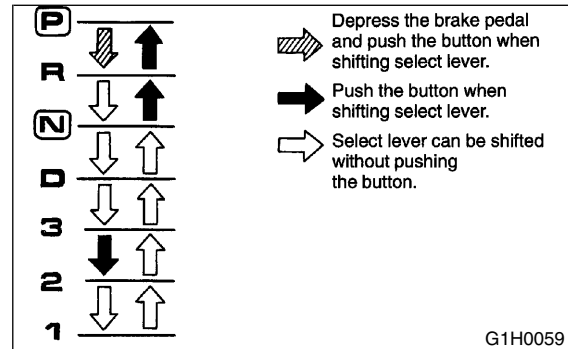

Selector Position	Gear Position			
	1st	2nd	3rd	4th
D	Yes	Yes	Yes	Yes
3	Yes	Yes	Yes	
2		Yes		
1	Yes			

## 38. HEATER & VENTILATION SA09719G5042

Operate the heater and ventilation system to check for normal airflow and heating capacity.

## 39. AIR CONDITIONER SA09719G5043

Operate the air conditioner. Check that the A/C compressor operates normally and enough cooling is provided.

## 40. CRUISE CONTROL SA09719G5044

Operate the cruise control system. Check that the system is activated and deactivated correctly.

## 41. ATF LEVEL SA09719G5045

Check that the ATF level is normal. If insufficient, check that no leaks are found. Then add the necessary amount of the specified ATF.

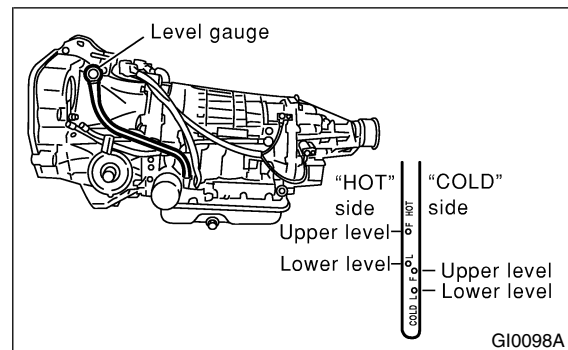



# PRE-DELIVERY INSPECTION

Pre-delivery Inspection

## 42. POWER STEERING FLUID LEVEL

SA09719G5046

Check that the power steering fluid level is normal. If insufficient, check that no leaks are found. Then add the necessary amount of the specified power steering fluid.

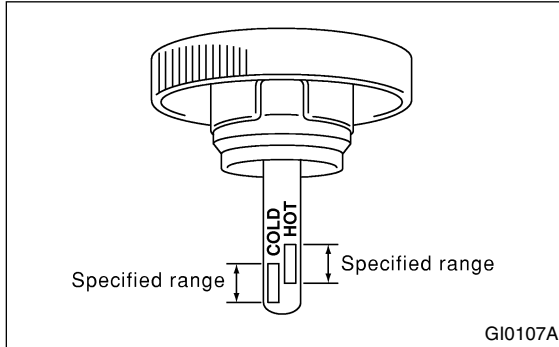

## 43. FLUID LEAK CHECK

SA09719G5047

Check the entire areas of the vehicle for any trace of coolant/oil/fluid leaks.

## 44. WATER LEAK TEST

SA09719G5048

Spray the vehicle with water and check that no water enters the passenger compartment.

- Before performing the water leakage test, remove anything that may obstruct the operation or which must be kept dry.

- Close all of the windows completely, and then close all of the doors tightly. Close the hood and trunk lid before starting the test.

- Connect a hose to a tap, and spray water on the vehicle. The rate of water discharge must be approx. 20 to 25 liters (5.3 to 6.6 US gal, 4.4 to 5.5 Imp gal) per minute.

When spraying water on areas adjacent to the floor and wheel house, increase the pressure. When directing water on areas other than the floor portion and wheel house, decrease the pressure. But the force of water must be made strong occasionally by pressing the end of the hose.

NOTE:

Be sure to keep the hose at least 10 cm (3.9 in) from the vehicle.

- Check the following areas:
  - Front window and body framework mating portion
  - Door mating portions
  - Glass mating portions
  - Rear quarter window mating portions
  - Rear window and body framework mating portion
  - Around roof drips
- If any dampness in the compartments is discovered after the water has been applied, carefully check all areas that may have possibly contributed to the leak.

## 45. APPEARANCE CHECK 2

SA09719G5049

Check the vehicle body paints, plated faces, glass, and lenses for any dirt or damage.