

OIL SEAL AND PACKING

Power Assisted System (Power Steering)

4. Oil Seal and Packing S601546

A: REPLACEMENT S601546A20

1. VALVE HOUSING OIL SEAL S601546A2001

Specified steering grease:

VALIANT GREASE M2 (Part No. 003608001)

1) Using ST and press, remove dust seal, oil seal and special bearing from valve housing.

ST 34099FA120 INSTALLER & REMOVER SEAL

CAUTION:

- Do not apply a force to end surface of valve housing.
- Do not reuse oil seal after removal.

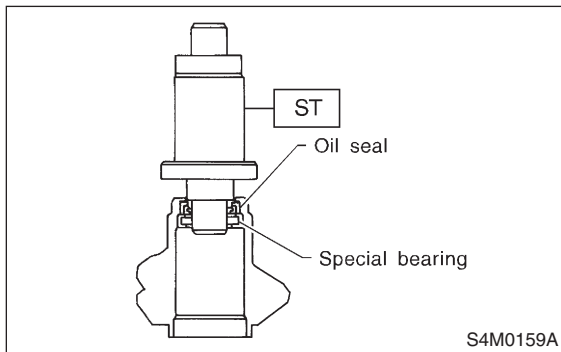

2) Apply a coat of specified power steering fluid to inner wall of valve housing.

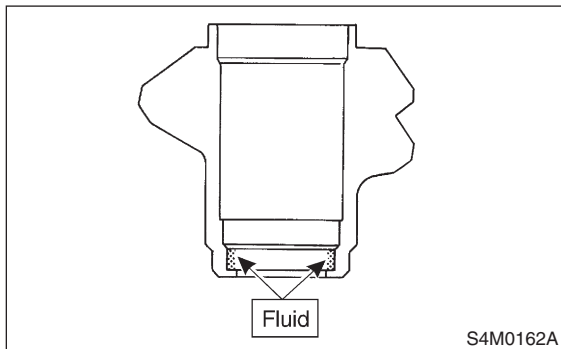

3) Attach ST2 to ST1, and press oil seal into place using a press.

ST1 34099FA120 INSTALLER & REMOVER SEAL

ST2 34099FA130 INSTALLER SEAL

(1) Face oil seal in the direction shown in figure when installing.

(2) To avoid scratching oil seal, apply a coat of grease to contact surface of installer and oil seal.

(3) To facilitate installation, attach oil seal to installer and position in valve housing before pressing into place.

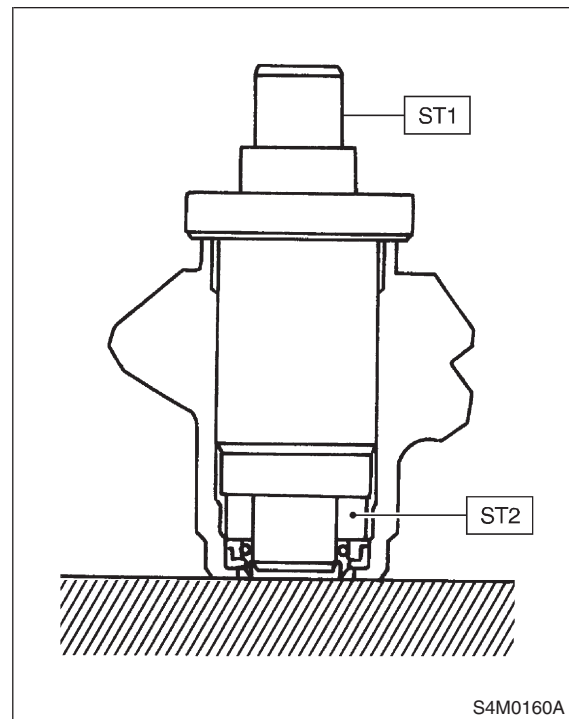

4) Using ST and press, install special bearing in valve housing.

ST 34099FA120 INSTALLER & REMOVER SEAL

NOTE:

To facilitate installation, attach ball bearing to remover and position in valve housing before pressing it into place.

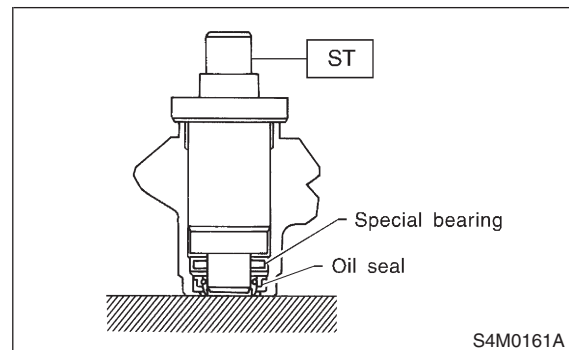

OIL SEAL AND PACKING

Power Assisted System (Power Steering)

2. PINION AND VALVE ASSEMBLY S601546A2002

1) Remove snap ring using snap ring pliers.

CAUTION:

- Do not reuse removed snap ring.
- Be careful not to scratch pinion and valve assembly.

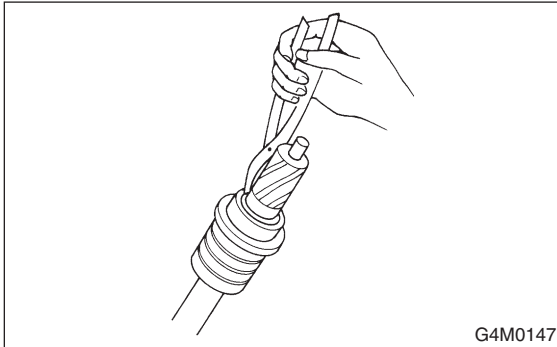

2) Press out bearing together with backing washer using pipe of I.D. 38.5 to 39.5 mm (1.516 to 1.555 in) and press.

CAUTION:

Do not reuse removed bearing.

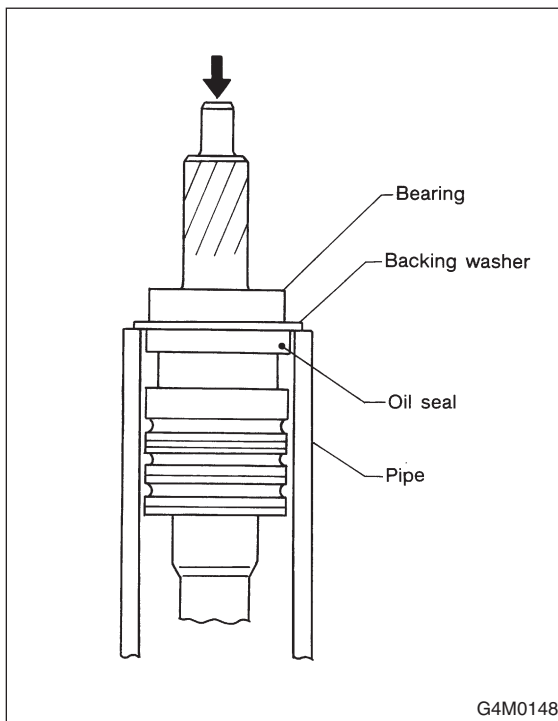

3) Remove oil seal.

CAUTION:

Do not reuse removed oil seal.

4) Put vinyl tape around pinion shaft splines to protect oil seal from damage.

5) Fit pinion and valve assembly into valve housing.

NOTE:

Apply specified power steering fluid to outer diameter surface of input shaft and outer surface of valve body seal ring, and pay special attention not to damage seal when inserting pinion and valve assembly.

6) Secure valve assembly to ST1 and ST2.

7) Put ST3 over pinion, and insert oil seal, then force-fit oil seal into housing using ST4.

- | | | |
|-----|------------|-------------|
| ST1 | 926370000 | INSTALLER A |
| ST2 | 34099FA100 | STAND BASE |
| ST3 | 926360000 | INSTALLER A |
| ST4 | 927620000 | INSTALLER B |

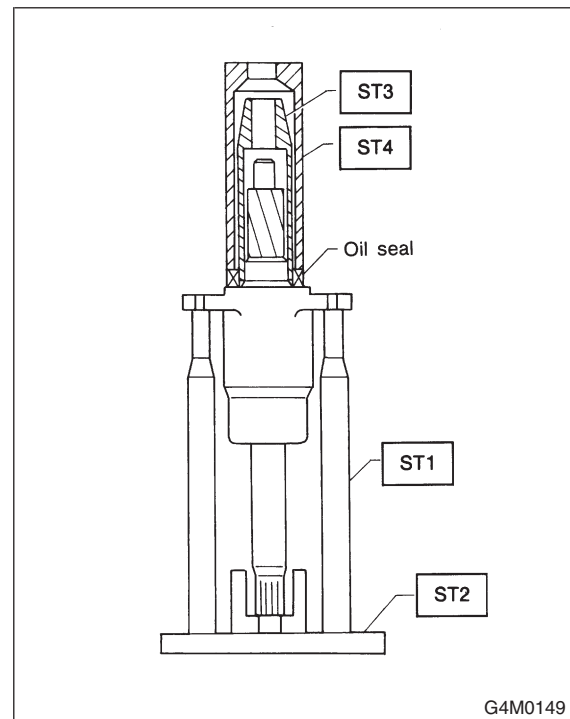

NOTE:

- Apply specified power steering fluid to oil seal and ST3, being careful not to damage oil seal lip.
- Push oil seal until ST3 contacts housing end face.

8) Remove ST3, and fit backing washer.

OIL SEAL AND PACKING

Power Assisted System (Power Steering)

- 9) Force-fit ball bearing using ST3.
ST1 926370000 INSTALLER A
ST2 34099FA100 STAND BASE
ST3 927640000 INSTALLER B

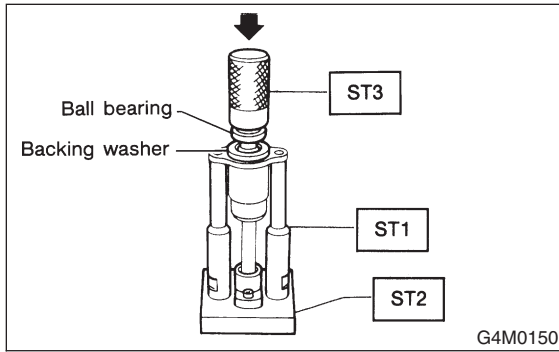

NOTE:
Be careful not to tilt ball bearing during installation.

- 10) Install snap ring using snap ring pliers.

NOTE:
Rotate snap ring to check for proper installation.

3. RACK HOUSING OIL SEAL S601546A2003

- 1) Insert ST from pinion housing side and remove oil seal using a press.
ST 34199AE050 REMOVER OIL SEAL

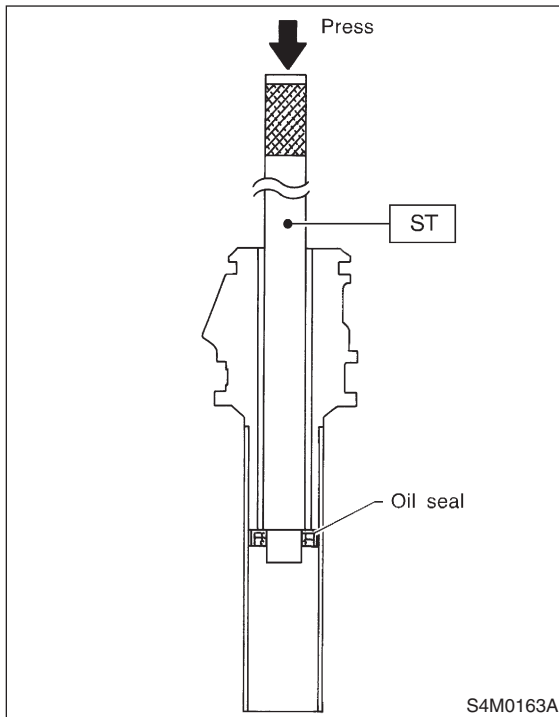

NOTE:
Discard removed oil seal.

- 2) Force-fit oil seal using ST.
ST 34099FA110 INSTALLER

CAUTION:
Be careful not to damage or scratch cylinder inner wall.

NOTE:
● Apply specified power steering fluid to oil seal.
● Pay special attention not to install oil seal in wrong direction.
● Push oil seal until the stepped portion of A contacts end face of B.

