

## 6. Air Conditioning System S903471

### A: SCHEMATIC S903471A21

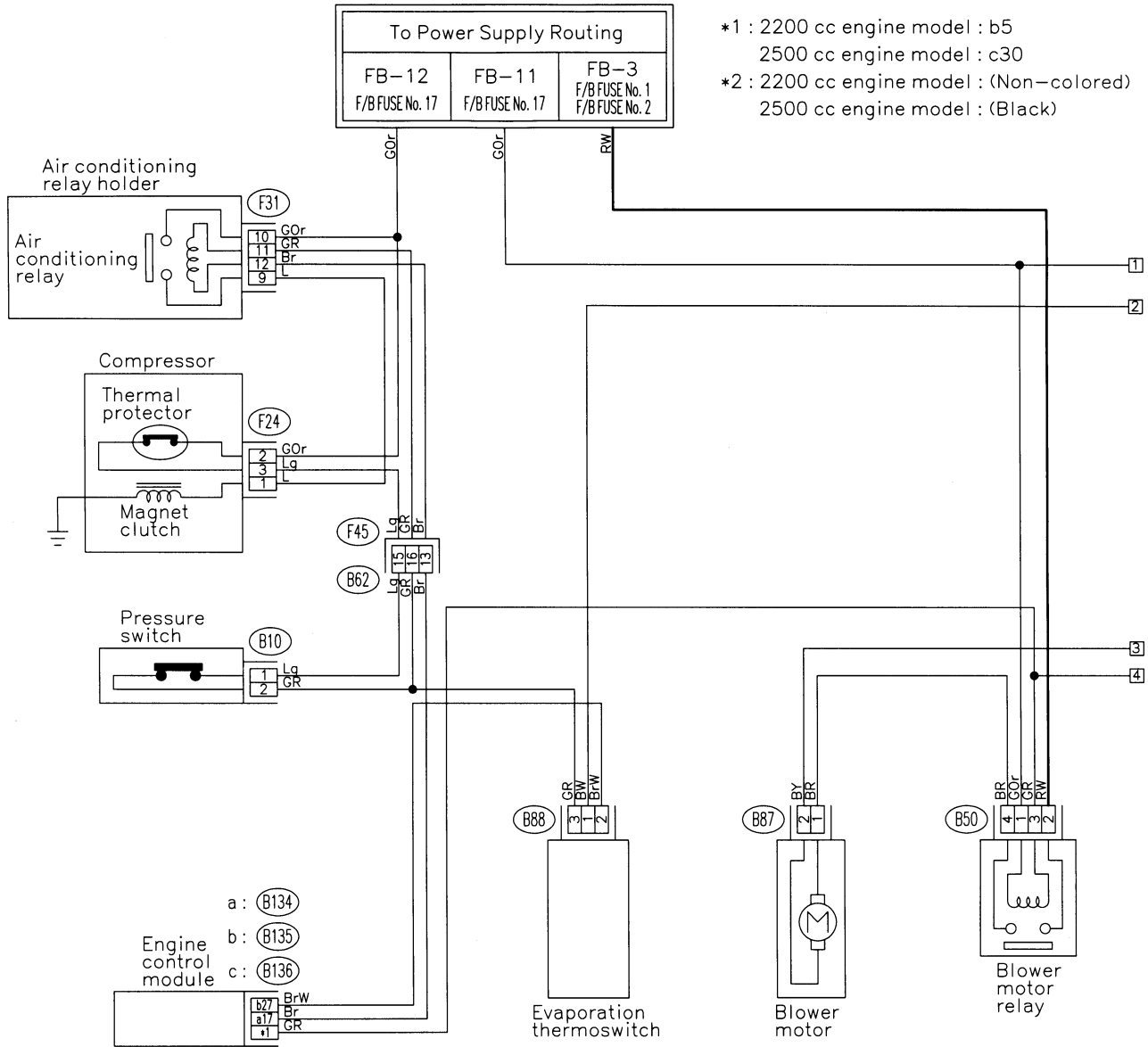

(B87)    (B10)    (F24)    (B88)    (B50)    (B62)    (F27)    (F31)    (F28)    (F66)    (F67)

(Gray)    (Gray)    (Brown)

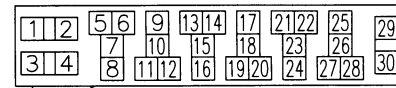
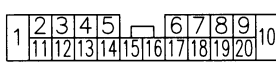

a : (B134) (\*2)

b : (B135) (\*2)

c : (B136) (\*2)

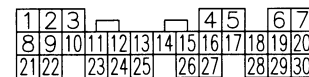
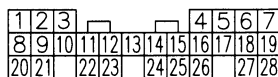
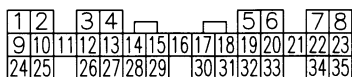

# AIR CONDITIONING SYSTEM

Wiring System

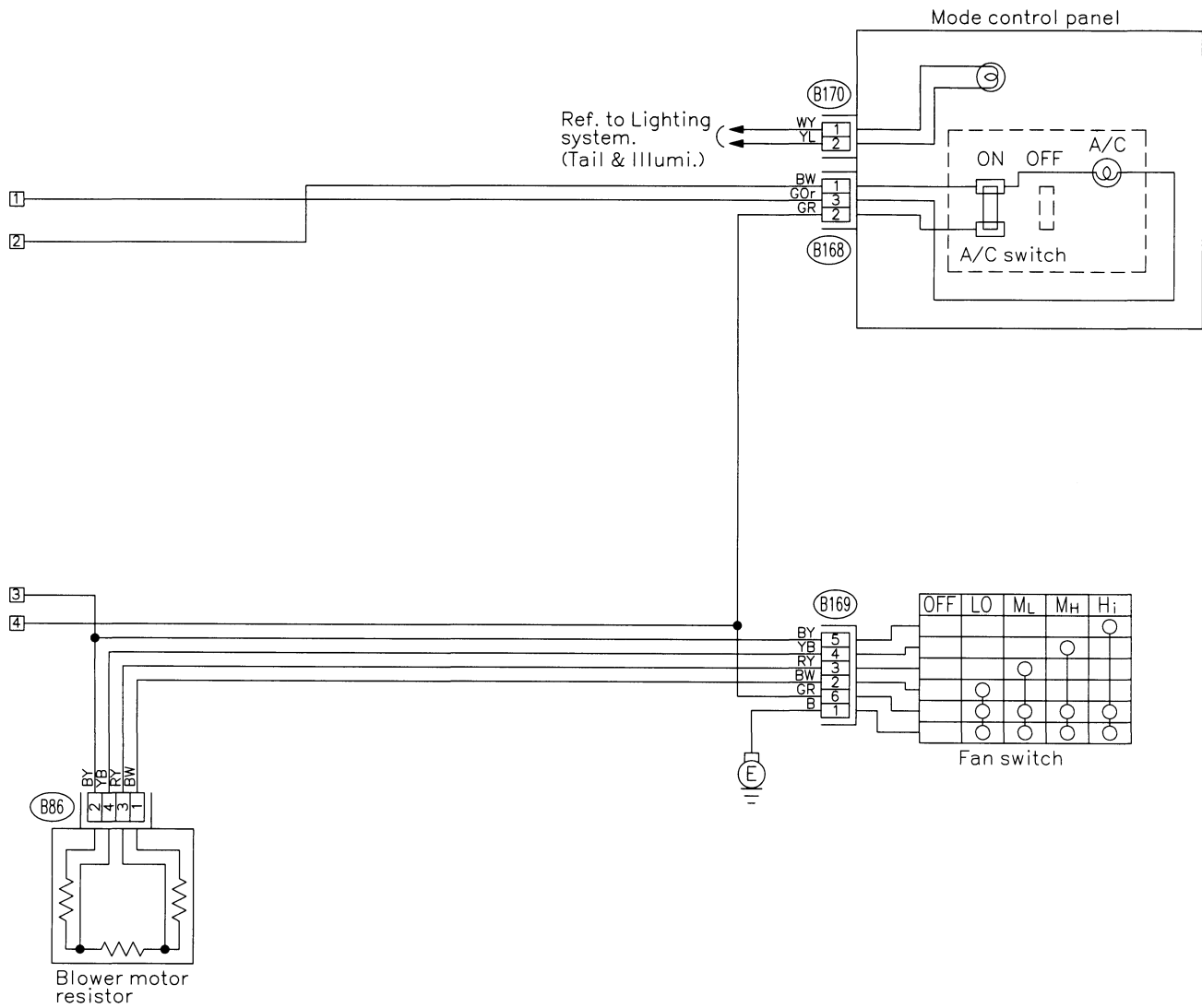

(B170)



(B168)



(B86)



(B169)

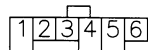

GU45-07B