

1. Precaution

A: PRECAUTION

Please clearly understand and adhere to the following general precautions. They must be strictly followed to avoid minor or serious injury to the person doing the work or people in the area.

1. ABS

Handle the ABS as a total system. Do not disassemble or attempt to repair individual parts. Doing so could prevent the ABS system from operating when needed or cause it to operate incorrectly and result in injury.

2. BRAKE FLUID

If brake fluid gets in your eyes or on your skin, do the following:

- Wash out your eyes and seek immediate medical attention.
- Wash your skin with soap and then rinse thoroughly with water.

3. ELECTRIC FAN

The electric fan may rotate without warning, even when the engine is not on. Do not place your hand, cloth, tools, or other items near the fan at any time.

4. ROAD TESTS

Always conduct road tests in accordance with traffic rules and regulations to avoid bodily injury and interrupting traffic.

5. AIRBAG

To prevent bodily injury from unexpected deployment of airbags and unnecessary maintenance, follow the instructions in this manual when performing maintenance on airbag components or nearby, and airbag wiring harnesses or nearby.

To prevent unexpected deployment, perform one of the steps below and then wait at least 20 seconds to discharge electricity before beginning work.

- Step 1: Turn the ignition switch to OFF.
- Step 2: Disconnect the ground cable from battery.

6. AIRBAG DISPOSAL

To prevent bodily injury from unexpected airbag deployment, do not dispose airbag modules in the same way as other refuse. Follow all government regulations concerning disposal of refuse.

7. AIRBAG MODULE

Adhere to the following when handling and storing the airbag module to prevent bodily injury from unexpected deployment:

- Do not hold the harnesses or connectors to carry a module.
- Do not face the bag in the direction that it deploys towards yourself or other people.
- Do not face the bag in the direction that it deploys towards the floor or walls.

8. AIRBAG SPECIAL TOOLS

To prevent unexpected deployment, only use special tools.

9. WINDOW

Always wear safety glasses when working around any glass to prevent glass fragments from damaging your eyes.

10. WINDOW ADHESIVE

Always use the specified urethane adhesive when attaching glass to prevent it from coming loose and falling, resulting in accidents and injury.

11.HOSE REMOVAL/INSTALLATION PROCEDURES

1. Hose Removal/Installation Pre-Procedures

- Be careful to inspect hoses so as not to use damaged or deformed hoses. Using such hoses could cause leakage or loss of oil, with leaked oil splashing on exhaust pipes or other hot parts, resulting in smoke or fire.
- Always remove hoses when performing work. Not removing the hoses and moving parts out of the way when performing procedures may damage the inside of hoses and cause other negative affects.

2. Hose Removal/Installation Procedures and Inspection

- **Remove hoses according to the following instructions.**
 - If using the hose remover (general tool), do not use the sharp-pointed hose remover (hose plucker) as it may damage pipe surfaces or hoses.

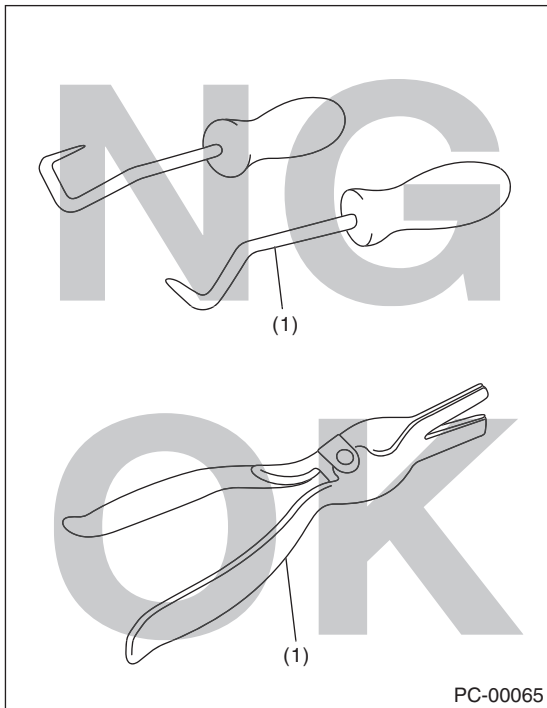

(1) Hose remover

- When using pliers to make hose removal easier, always be sure to use a cloth to protect the hose, slightly rotate the hose, and then pull straight out by hand.

- **Inspect the following points in continuous use, and replace any hoses that are damaged or defective with new parts.**

- Replace any hoses that are riding over the stay or spool with new parts.

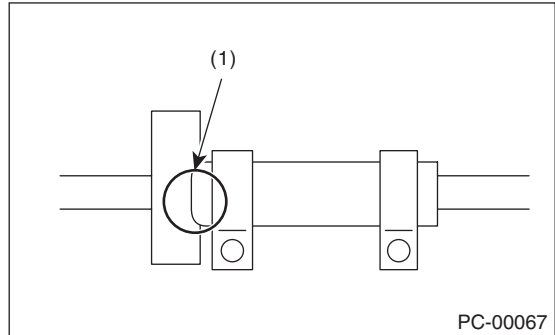

(1) Hose riding over a stay

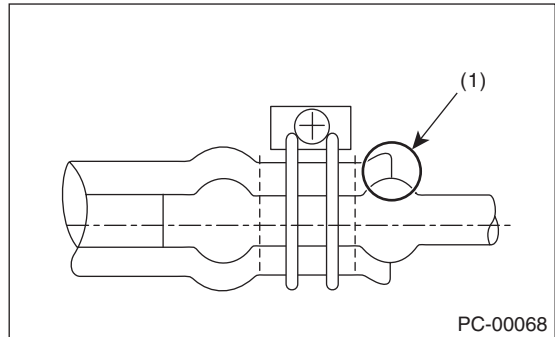

(1) Hose riding over a spool

- Check the inner and outer surfaces of the hose for damage, cracks, breakage, hardening/softening/swelling of rubber, internal peeling, and that there are no deformations caused by infiltration/adhesion of foreign matter, and no twisted hoses. Replace any defective hoses with new parts.

PRECAUTION

PRECAUTION

- **Install hoses according to the following instructions.**

- Carefully check the installation positions.
- Do not use any lubricants.
- Securely insert until the specified positions (until contacting spool).

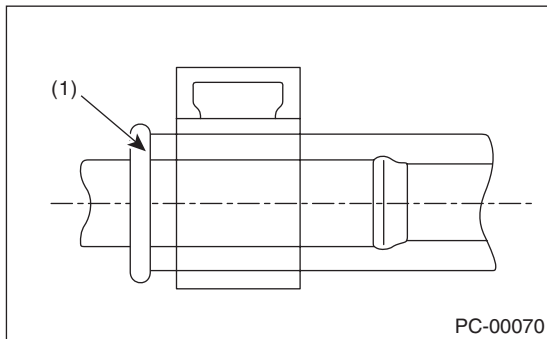
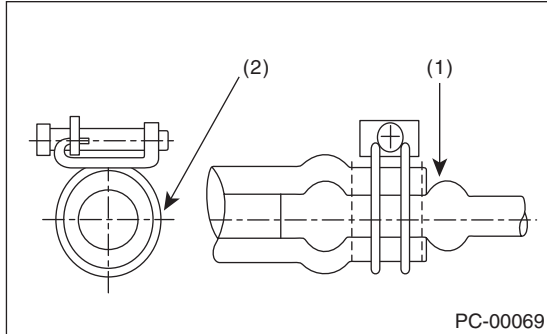

- (1) Contacting the spool. (Do not excessively insert the hose to prevent the hose from becoming wrinkled up.)
- (2) Apply an equal clamping force all around the hose periphery.

- Check that the position and orientation of hose clamps, and the hose layout are correct. (Check that the position and orientation are matching, they are not excessively short/long, there are no differences with before performing the procedures, and that there is clearance between hoses and surrounding parts.)
- After installing, check that there are no disconnection of hoses or leakage from hoses. (Check that hoses are securely fixed by the clamps.)
- **Inspect the hose clips and clamps according to the following points, and replace any parts that are damaged or defective with new parts.**
 - Check for deformations, rust, damage, and adhering of foreign matter.
 - For clips, check that the spring functions and has clamping force.
 - For clamps, check that the screw can clinch, the clamp has not become oval shaped, and the screw is not damaged.

- **Inspect the pipes according to the following points, and replace any parts that are damaged or defective with new parts.**

Check that the pipes do not have any damage, rust, peeling (including peeling plating), foreign matter adhering, twisting, crushing, bending, or cracks.

- **Replace the following parts with new parts if the hoses have been removed or their installation positions have been changed.**

ATF cooler hose, engine oil cooler hose, MT oil cooler hose, power steering suction hose, and power steering return hose.