

OPTION PARTS

General Description

OPTION PARTS

1. General Description

A: COMPONENT

1. REAR SPOILER

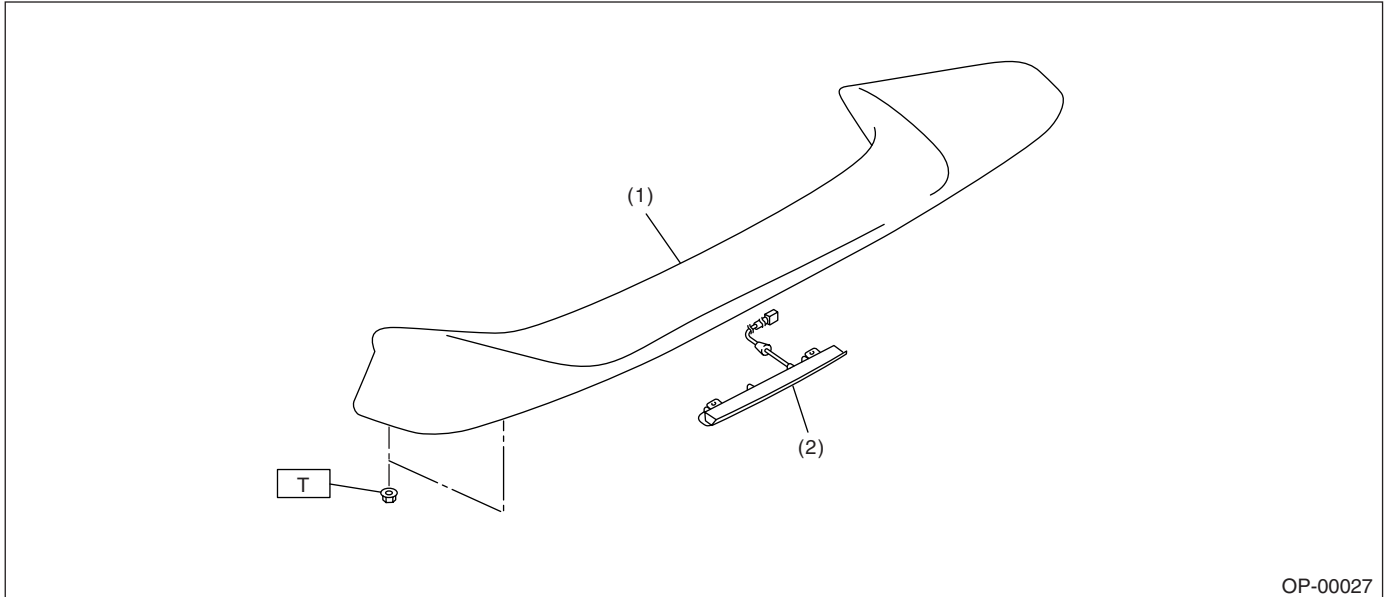

(1) Rear spoiler

(2) High mounted stop light

Tightening torque: N·m (kgf·m, ft·lb)
T: 7.5±2 (0.76±0.20, 5.5±1.4)

2. CROSSBAR

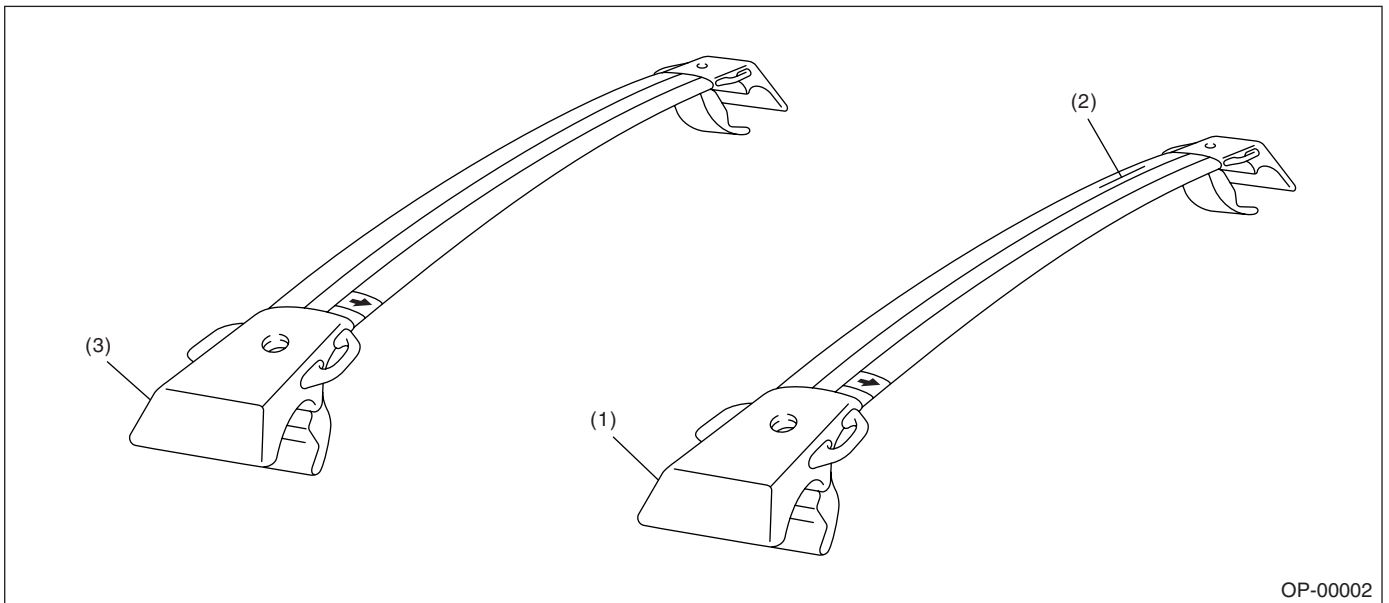

(1) Front crossbar

(2) Caution label (Front crossbar)

(3) Rear crossbar

3. TRAILER HITCH

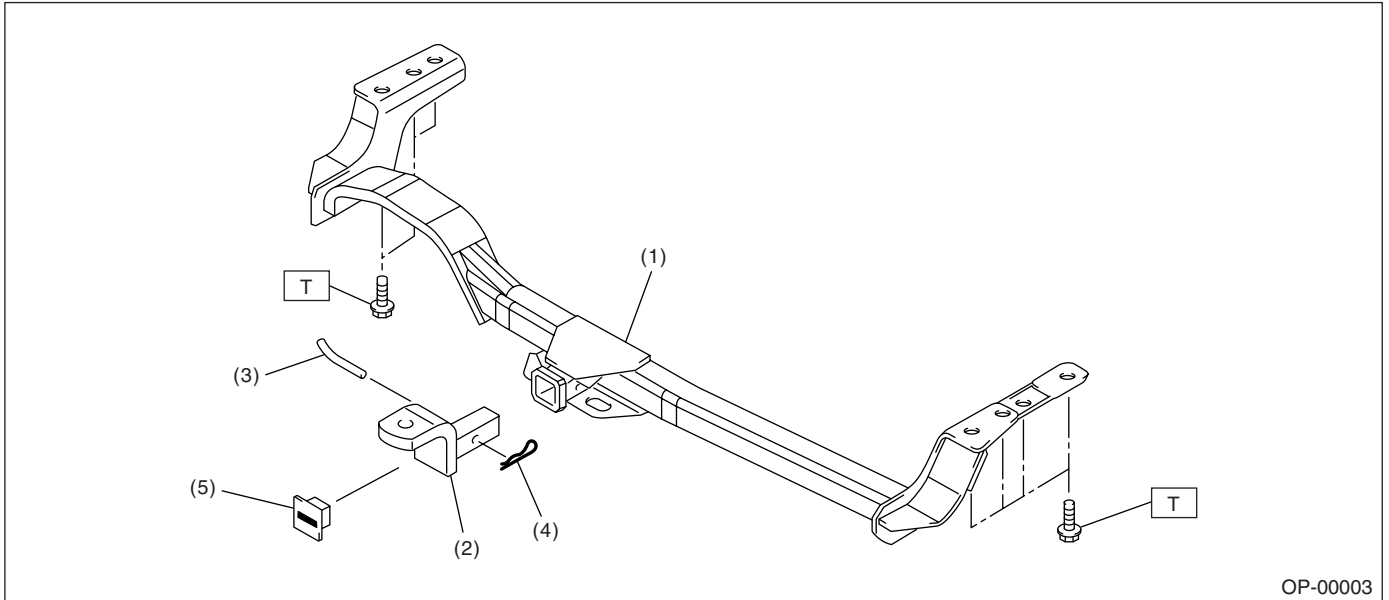

OP-00003

- | | |
|--------------------|---------------------|
| (1) Receiver hitch | (4) Ball mount clip |
| (2) Ball mount | (5) Receiver cover |
| (3) Ball mount pin | |

Tightening torque: N·m (kgf·m, ft·lb)
T: 95 (9.7, 70)

General Description

OPTION PARTS

4. REAR DIFFERENTIAL PROTECTOR

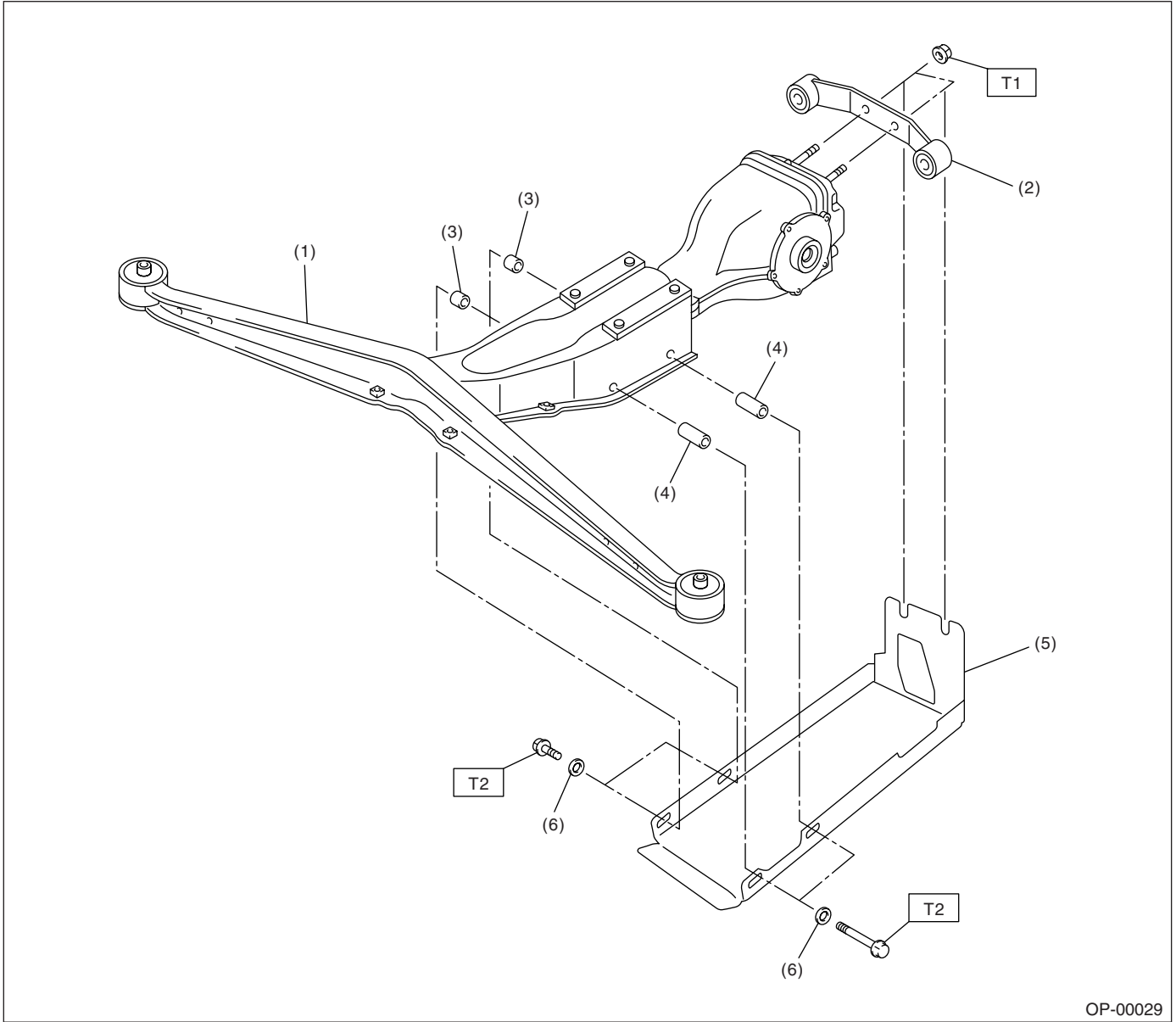

- | | |
|-------------------------------|---------------------------------|
| (1) Differential front member | (4) Spacer (Long) |
| (2) Differential rear member | (5) Rear differential protector |
| (3) Spacer (Short) | (6) Washer |

Tightening torque: N·m (kgf·m, ft·lb)

T1: 70 (7.1, 51.6)

T2: 90 (9.2, 66.4)

2. Rear Spoiler

A: REMOVAL

- 1) Disconnect the ground cable from battery.
- 2) Open the trunk lid.
- 3) Disconnect the connector of high mounted stop light.

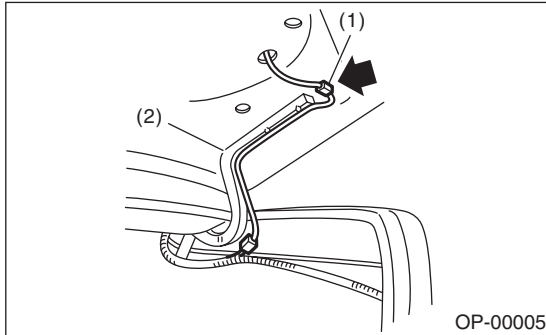

- (1) Connector
(2) Trunk hinge

- 4) Remove the mounting nuts of rear spoiler.

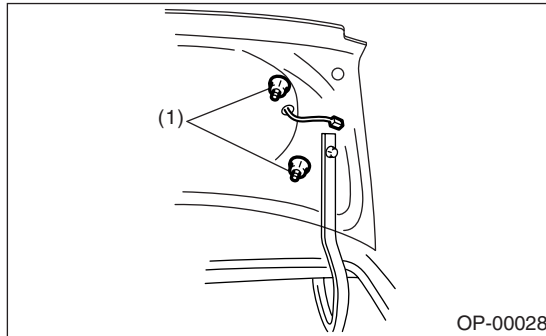

- (1) Mounting nut

- 5) Remove the rear spoiler.

CAUTION:

Pay attention to avoid damage during removal or installation.

B: INSTALLATION

Install in the reverse order of removal.

Tightening torque:

Rear spoiler to trunk lid

7.5 ± 2 N·m (0.76 ± 0.20 kgf·m, 5.5 ± 1.4 ft·lb)

Crossbar

OPTION PARTS

3. Crossbar

A: REMOVAL

- 1) Remove the TORX[®] bolt T30 from each end support.
- 2) Rotate the lower clamp of each end support about 90° downward to remove the crossbar.

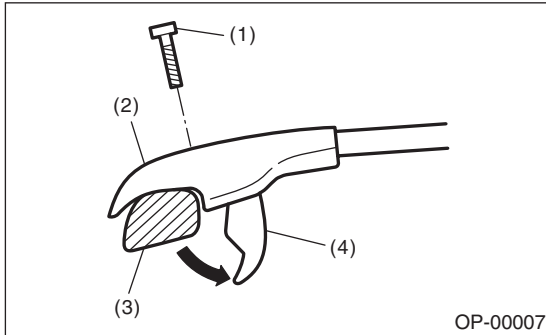

- (1) TORX[®] bolt T30
- (2) End support
- (3) Roof rail
- (4) Lower clamp

CAUTION:

Pay attention to avoid damage to the roof panel during removal or installation.

B: INSTALLATION

- 1) Rotate the lower clamp of each end support about 90° downward.
- 2) Set the front crossbar so that front direction mark on the right side top face of crossbar point in the direction of vehicle front.
- 3) Place the crossbar end support in a position 76.2 mm (3 in) behind the joint of front roof rail support and roof rail.

Length A:

76.2 mm (3 in)

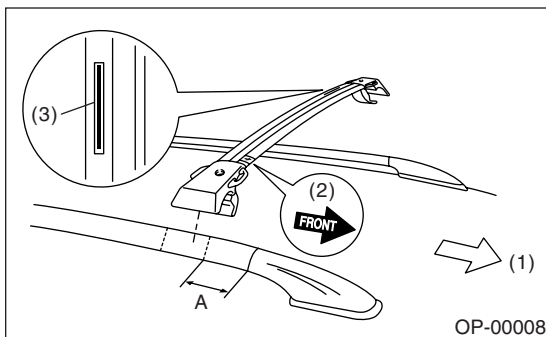

- (1) Front of vehicle
- (2) Front direction mark
- (3) Caution label (Front crossbar)

- 4) Set the rear crossbar so that front direction mark on the right side top face of crossbar point in the direction of vehicle front.
- 5) Place the crossbar end support on a joint of rear roof rail support and roof rail.

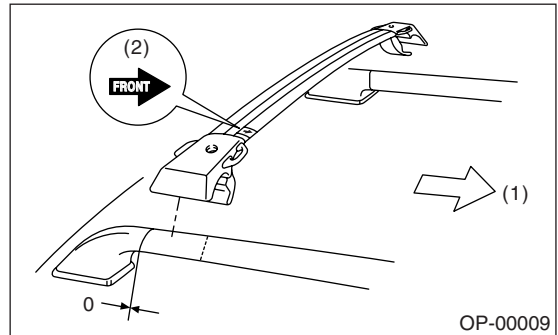

- (1) Front of vehicle
- (2) Front direction mark

- 6) Tighten the end support and clamp using TORX[®] bolt T30.

4. Trailer Hitch

A: REMOVAL

CAUTION:

Because the trailer hitch is heavy, two people are required to remove it.

- 1) Lift-up the vehicle.
- 2) Remove the cushion rubber from body.

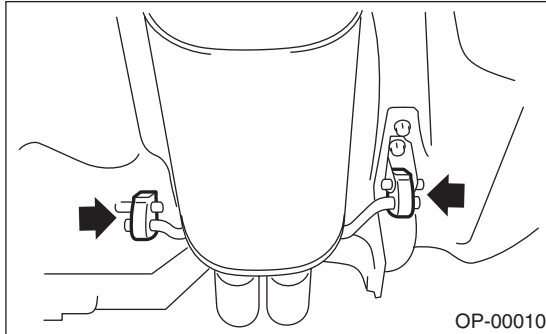

- 3) Remove the canister. <Ref. to EC(H4SO)-6, REMOVAL, Canister.>
- 4) Remove the trailer hitch installation bolts.

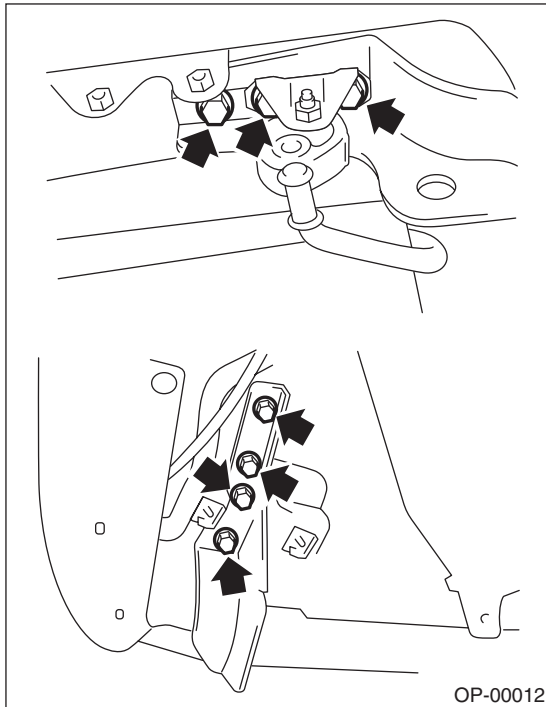

- 5) Remove the trailer hitch while lowering exhaust pipe.

B: INSTALLATION

CAUTION:

Because the trailer hitch is heavy, two people are required to install it.

Install in the reverse order of removal.

Tightening torque:

Trailer hitch to body:

95 N·m (9.7 kgf-m, 70 ft-lb)

Canister:

23 N·m (2.3 kgf-m, 17 ft-lb)

Rear Differential Protector

OPTION PARTS

5. Rear Differential Protector

A: REMOVAL

- 1) Remove the rear exhaust pipe and muffler. <Ref. to EX(H4SO)-7, Rear Exhaust Pipe.> <Ref. to EX(H4SO)-8, Muffler.> <Ref. to EX(H4DOTC)-15, Rear Exhaust Pipe.> <Ref. to EX(H4DOTC)-16, Muffler.>
- 2) Remove the differential front member installation bolts.

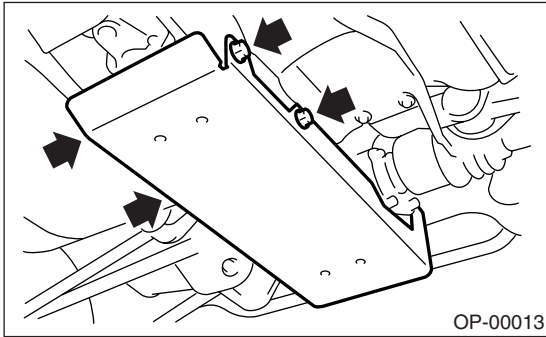

- 3) Loosen the nuts until the rear differential protector can be removed.

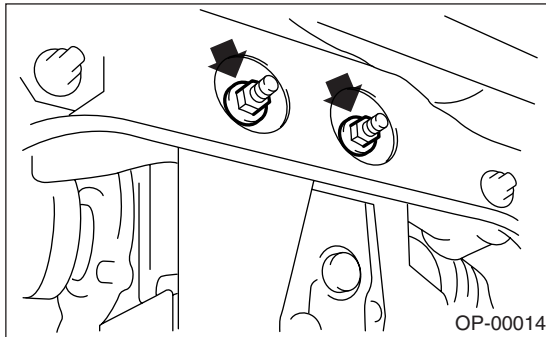

- 4) Remove the rear differential protector.

B: INSTALLATION

Install in the reverse order of removal.

Tightening torque:

90 N·m (9.2 kgf·m, 66.4 ft·lb)

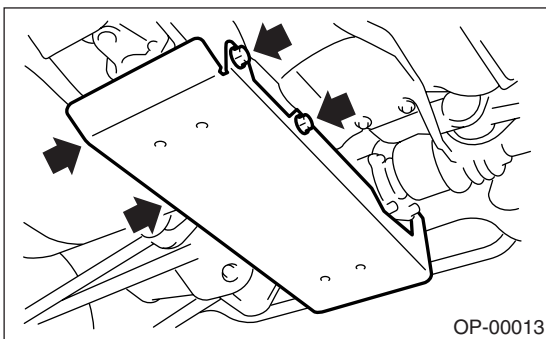

NOTE:

Install the protector between the nuts and differential rear member.

Tightening torque:

70 N·m (7.1 kgf·m, 51.6 ft·lb)

