

# **SPEED CONTROL SYSTEMS**

# General Description

SPEED CONTROL SYSTEMS

## 1. General Description

### A: SPECIFICATION

Accelerator pedal	Stroke	At pedal pad	50 — 55 mm (1.97 — 2.17 in)
-------------------	--------	--------------	-----------------------------

### B: COMPONENT

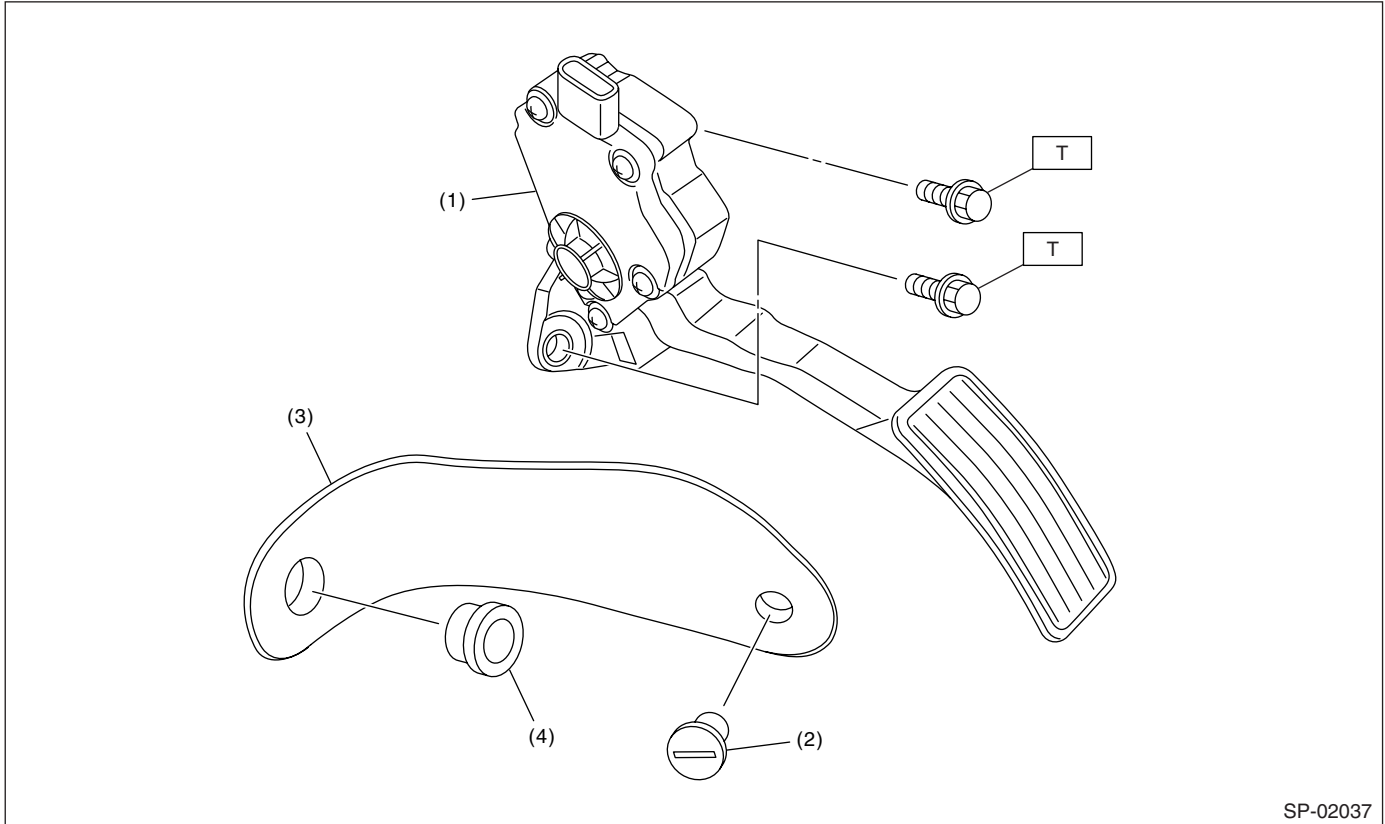

SP-02037

- |                            |                       |
|----------------------------|-----------------------|
| (1) Accelerator pedal ASSY | (3) Accelerator plate |
| (2) Clip                   | (4) Stopper           |

**Tightening torque: N-m (kgf-m, ft-lb)**  
**T: 18 (1.8, 13.0)**

### C: CAUTION

- Wear work clothing, including a cap, protective goggles and protective shoes during operation.
- Remove contamination including dirt and corrosion before removal, installation or disassembly.
- Keep the disassembled parts in order and protect them from dust and dirt.
- Before removal, installation or disassembly, be sure to clarify the failure. Avoid unnecessary removal, installation, disassembly and replacement.
- Be careful not to burn yourself, because each part on the vehicle is hot after running.
- Be sure to tighten fasteners including bolts and nuts to the specified torque.
- Place shop jacks or rigid racks at the specified points.
- Before disconnecting electrical connectors of sensors or units, be sure to disconnect the ground cable from battery.

## 2. Accelerator Pedal

### A: REMOVAL

- 1) Disconnect the ground cable from battery.
- 2) Disconnect the connector (A).
- 3) Remove the bolt (B) securing accelerator pedal assembly.

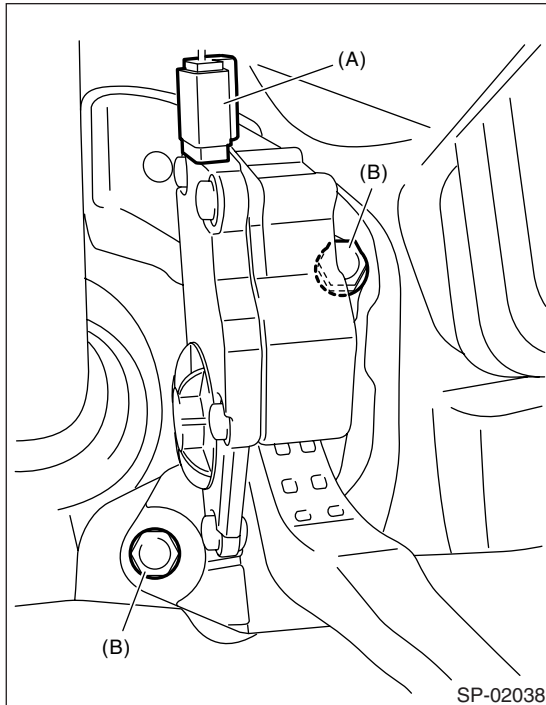

### B: INSTALLATION

Install in the reverse order of removal.

#### *Tightening torque:*

**18 N·m (1.8 kgf-m, 13.0 ft-lb)**

### C: DISASSEMBLY

NOTE:

Accelerator pedal cannot be disassembled.

