

AUTOMATIC TRANSMISSION

General Description

AUTOMATIC TRANSMISSION

1. General Description

A: SPECIFICATION

1. TORQUE CONVERTER CLUTCH

Model	Non-turbo	Turbo
Type	Symmetric, 3 element, single stage, 2 phase torque converter	
Stall torque ratio	2.05 — 2.35	
Nominal diameter mm (in)	246 (9.69)	
Stall speed (at sea level) rpm	2,200 — 2,700	2,700 — 3,200
One-way clutch	Sprague type one-way clutch	

2. OIL PUMP

Type	Parachoid constant-displacement pump	
Driving method	Driven by engine	
Number of teeth	Inner rotor	9
	Outer rotor	10

3. TRANSMISSION CONTROL ELEMENT

Type	4-forward, 1-reverse, double-row planetary gears
Multi-plate clutch	3 sets
Multi-plate brake	2 sets
One-way clutch (sprague type)	1 set

4. TRANSMISSION GEAR RATIO

1st	2.785
2nd	1.545
3rd	1.000
4th	0.694
Rev	2.272

5. PLANETARY GEAR AND PLATE

Model	Non-turbo	Turbo
Tooth number of front sun gear	33	
Tooth number of front pinion	21	
Tooth number of front internal gear	75	
Tooth number of rear sun gear	42	
Tooth number of rear pinion	17	
Tooth number of rear internal gear	75	
Drive plate number of high clutch	4	5
Drive plate number of low clutch	5	7
Drive plate number of reverse clutch	2	
Drive plate number of 2-4 brake	3	4
Drive plate number of low & reverse brake	5	7

6. SELECTOR POSITION

P (Park)	Transmission in neutral, output member immovable, and engine start possible
R (Reverse)	Transmission in reverse for backing
N (Neutral)	Transmission in neutral and engine start possible
D (Drive)	Automatic gear change 1st ← → 2nd ← → 3rd ← → 4th
3 (3rd)	Automatic gear change 1st ← → 2nd ← → 3rd ← 4th
2 (2nd)	2nd gear locked (Deceleration possible 2nd ← 3rd ← 4th)
1 (1st)	1st gear locked (Deceleration possible 1st ← 2nd ← 3rd ← 4th)
Control method	Wire cable type

General Description

AUTOMATIC TRANSMISSION

7. HYDRAULIC CONTROL AND LUBRICATION

Type	Electronic hydraulic control [Four forward speed changes by electrical signals of vehicle speed and accelerator (throttle) opening]	
Fluid	Recommended	SUBARU ATF Type-HP
	Alternative	Idemitsu: ATF HP Castrol: Transmax J Pennzoil Quaker State: Pennzoil ATF-J
Fluid capacity ℓ (US qt, Imp qt)	9.3 — 9.6 (9.8 — 10.1, 8.2 — 8.4)	
Lubrication system	Forced feed lubrication with oil pump	
Oil	Automatic transmission fluid (above mentioned)	

8. COOLING AND HARNESS

Cooling system	Liquid-cooled cooler incorporated in radiator
Inhibitor switch	12 poles
Transmission harness	20 poles

9. TRANSFER

Model	Non-turbo	Turbo
Transfer type	Multi-plate transfer (MP-T)	Variable torque distribution (VTD)
Drive & driven plate number of transfer clutch	5	3
Control method	Electronic hydraulic type	
Lubricant	The same Automatic transmission fluid used in automatic transmission	
1st reduction gear ratio	1.000 (53/53)	

10.FINAL REDUCTION

	Non-turbo	Turbo
Final gear ratio	4.111 (37/9)	3.900 (39/10)

11.RECOMMENDED GEAR OIL

Lubrication oil	<p>(1) Item (2) Front differential gear oil (3) API standard (4) SAE viscosity No. and applicable temperature</p>
	Front differential oil capacity ℓ (US qt, Imp qt)

General Description

AUTOMATIC TRANSMISSION

B: COMPONENT

1. TORQUE CONVERTER CLUTCH AND CASE

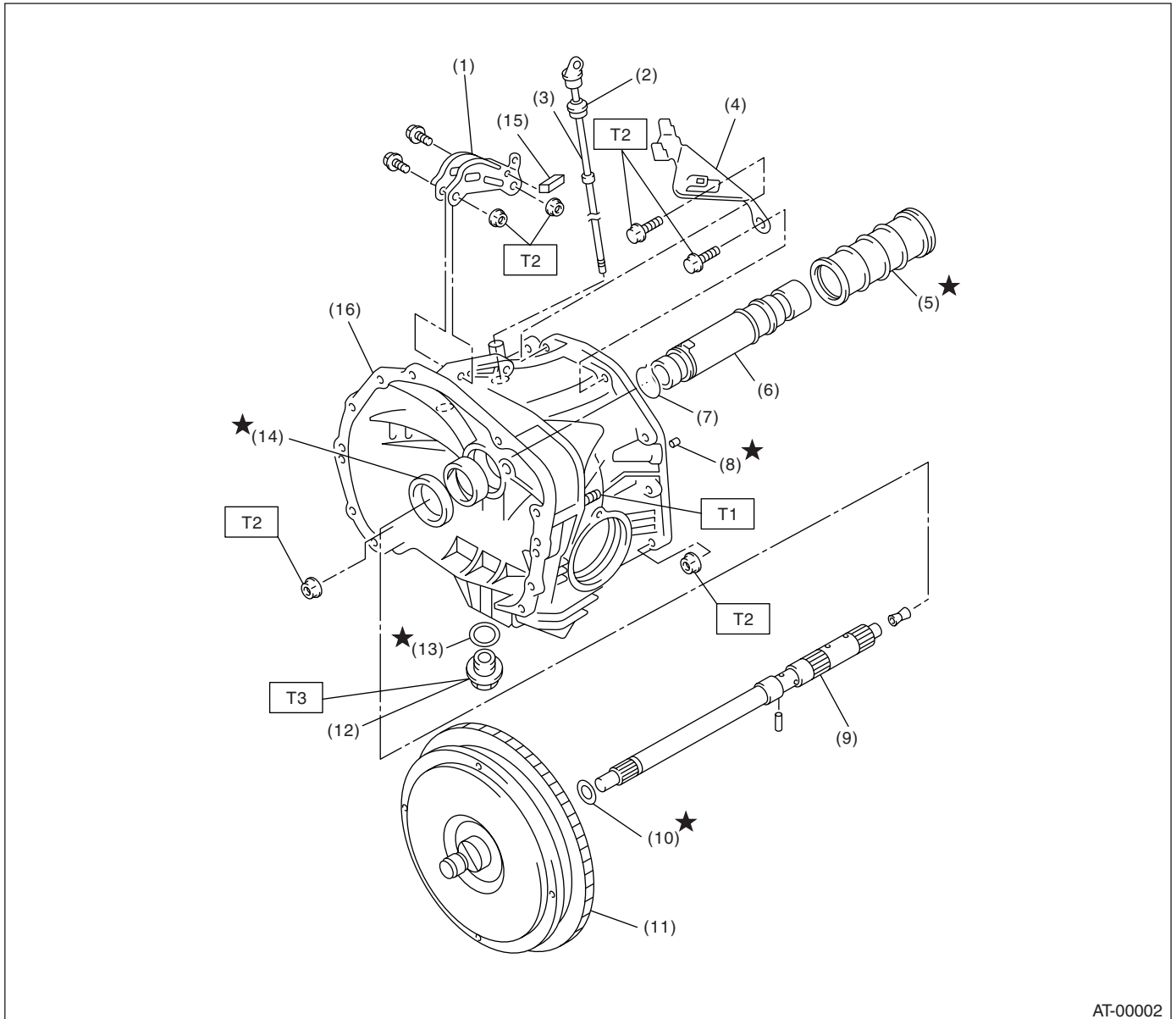

AT-00002

- | | |
|----------------------------------|-----------------------------------|
| (1) Pitching stopper bracket | (9) Input shaft |
| (2) O-ring | (10) O-ring |
| (3) Differential oil level gauge | (11) Torque converter clutch ASSY |
| (4) Stay | (12) Drain plug |
| (5) Seal pipe | (13) Gasket |
| (6) Oil pump shaft | (14) Oil seal |
| (7) Clip | (15) Clip (Turbo model) |
| (8) Rubber seal | (16) Converter case |

Tightening torque: N-m (kgf-m, ft-lb)

T1: 18 (1.8, 13.3)

T2: 41 (4.2, 30.2)

T3: 44 (4.5, 32.5) (Aluminum gasket)

70 (7.1, 51.6) (Copper gasket)

2. OIL PUMP

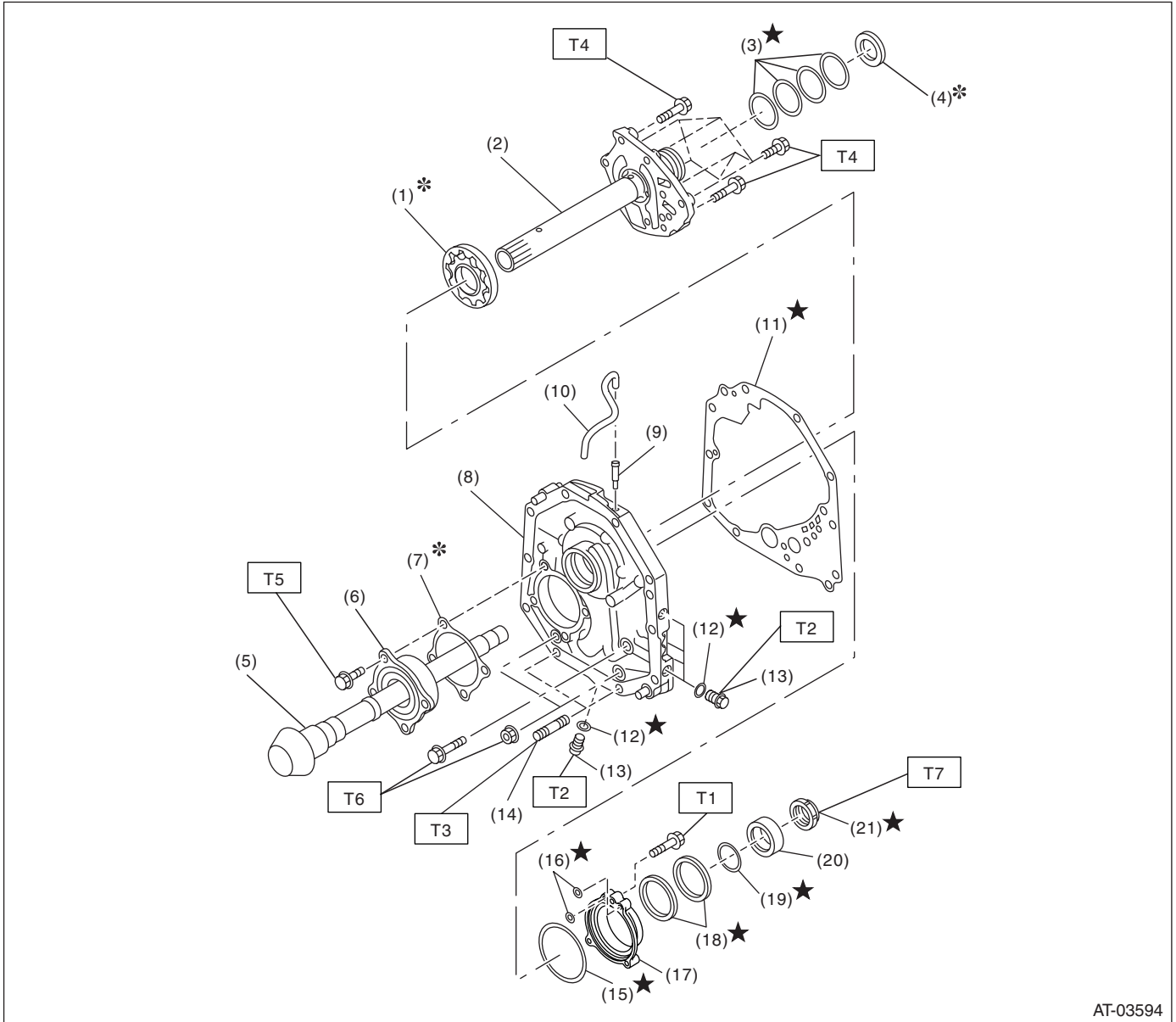

AT-03594

- | | | |
|---------------------------|--------------------------|---------------|
| (1) Oil pump rotor | (11) Gasket | (21) Lock nut |
| (2) Oil pump cover | (12) O-ring | |
| (3) Seal ring | (13) Test plug | |
| (4) Thrust needle bearing | (14) Stud bolt | |
| (5) Drive pinion shaft | (15) O-ring | |
| (6) Roller bearing | (16) O-ring | |
| (7) Shim | (17) Oil seal retainer | |
| (8) Oil pump housing | (18) Oil seal | |
| (9) Nipple | (19) O-ring | |
| (10) Air breather hose | (20) Drive pinion collar | |

Tightening torque: N-m (kgf-m, ft-lb)

- T1: 7 (0.7, 5.1)**
T2: 13 (1.3, 9.6)
T3: 18 (1.8, 13.3)
T4: 25 (2.5, 18.4)
T5: 40 (4.1, 30)
T6: 42 (4.3, 31)
T7: 116 (11.8, 85)

General Description

AUTOMATIC TRANSMISSION

3. TRANSMISSION CASE AND CONTROL DEVICE

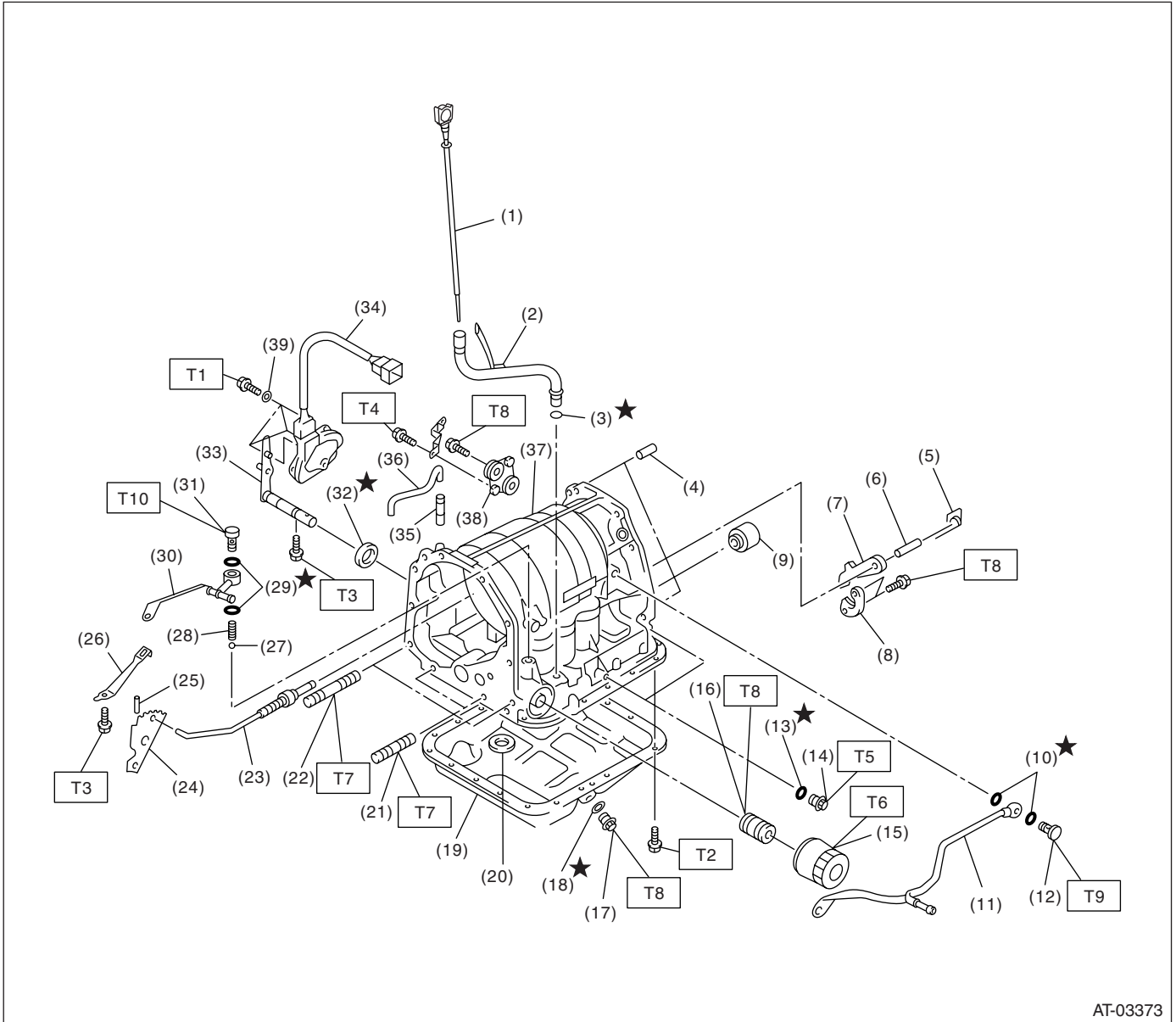

AT-03373

General Description

AUTOMATIC TRANSMISSION

(1) ATF level gauge	(18) Gasket	(35) Nipple
(2) Oil charge pipe	(19) Oil pan	(36) Air breather hose
(3) O-ring	(20) Magnet	(37) Transmission case
(4) Straight pin	(21) Stud bolt (Short)	(38) Plate ASSY
(5) Return spring	(22) Stud bolt (Long)	(39) Washer
(6) Shaft	(23) Parking rod	
(7) Parking pawl	(24) Manual plate	<hr/> Tightening torque: N-m (kgf-m, ft-lb)
(8) Parking support	(25) Spring pin	T1: 3.5 (0.36, 2.6)
(9) Transfer clutch seal	(26) Detent spring	T2: 5 (0.5, 3.6)
(10) Gasket	(27) Ball	T3: 6 (0.6, 4.3)
(11) Inlet pipe	(28) Spring	T4: 12 (1.2, 9)
(12) Union screw	(29) Gasket	T5: 13 (1.3, 9.6)
(13) O-ring	(30) Outlet pipe	T6: 14 (1.4, 10)
(14) Test plug	(31) Union screw	T7: 18 (1.8, 13.3)
(15) Oil filter	(32) Oil seal	T8: 25 (2.5, 18.4)
(16) Oil filter stud bolt	(33) Range select lever	T9: 40 (4.1, 30)
(17) Drain plug	(34) Inhibitor switch ASSY	T10: 45 (4.6, 33)

General Description

AUTOMATIC TRANSMISSION

4. CONTROL VALVE AND HARNESS ROUTING

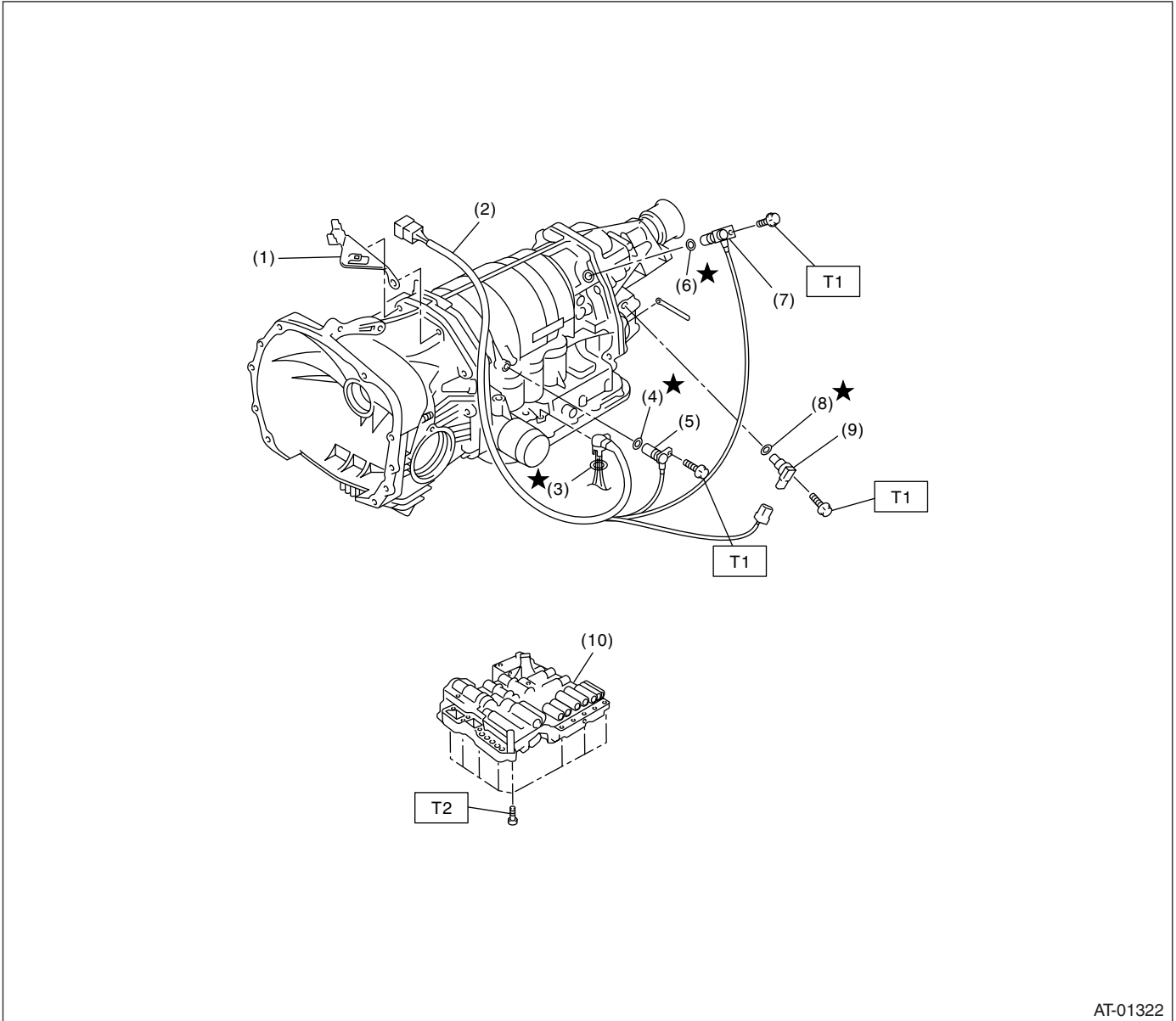

AT-01322

- | | |
|---|--------------------------------|
| (1) Stay | (6) O-ring |
| (2) Transmission harness | (7) Front vehicle speed sensor |
| (3) O-ring | (8) O-ring |
| (4) O-ring | (9) Rear vehicle speed sensor |
| (5) Torque converter turbine speed sensor | (10) Control valve ASSY |

Tightening torque: N·m (kgf·m, ft·lb)

T1: 7 (0.7, 5.1)

T2: 8 (0.8, 5.8)

5. HIGH CLUTCH AND REVERSE CLUTCH

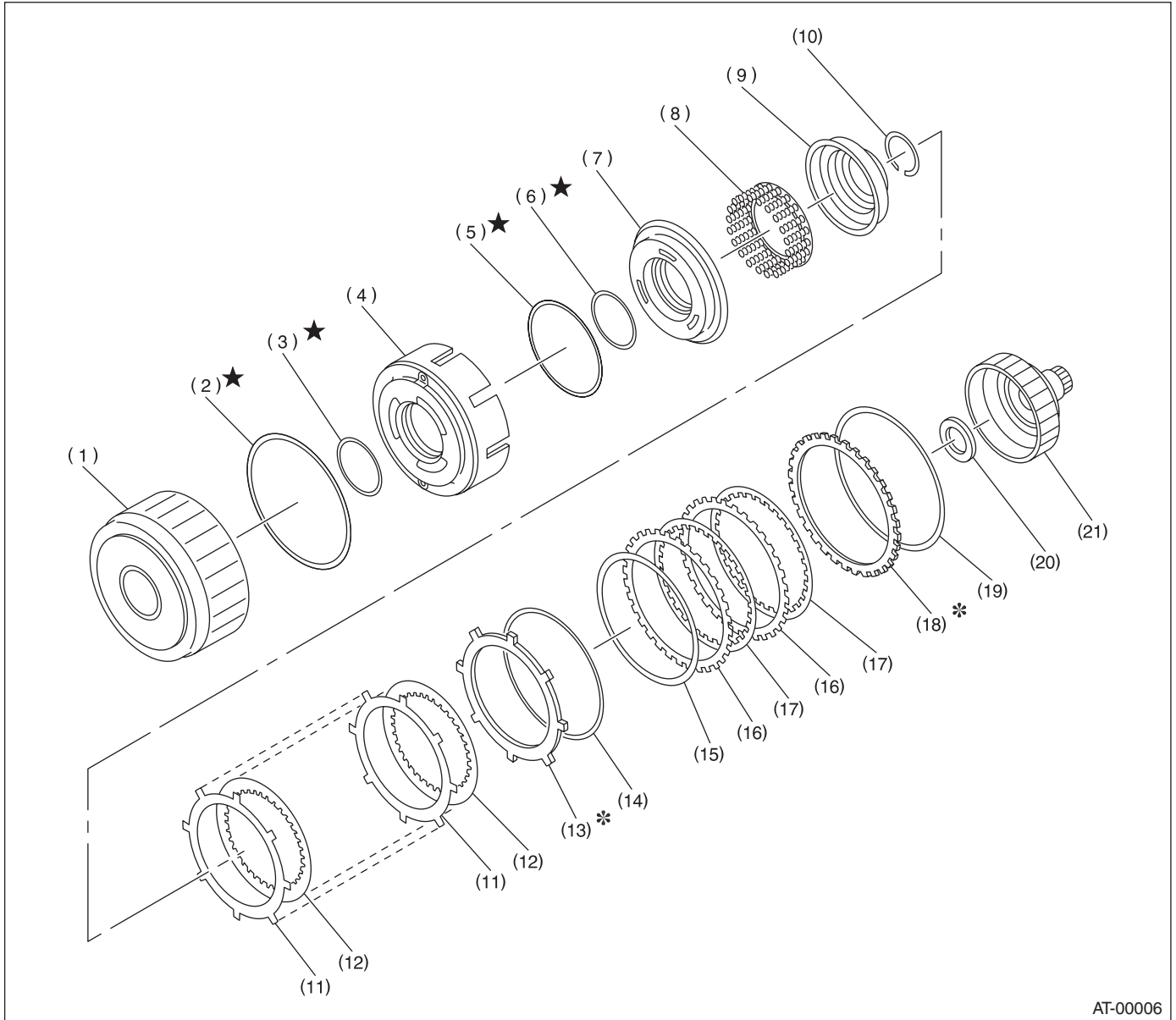

AT-00006

- | | | |
|---------------------------|------------------------------------|---------------------------------------|
| (1) High clutch drum | (8) Spring retainer | (15) Dish plate |
| (2) Lip seal | (9) Cover | (16) Driven plate (Reverse clutch) |
| (3) D-ring | (10) Snap ring | (17) Drive plate (Reverse clutch) |
| (4) Reverse clutch piston | (11) Driven plate (High clutch) | (18) Retaining plate (Reverse clutch) |
| (5) D-ring | (12) Drive plate (High clutch) | (19) Snap ring |
| (6) D-ring | (13) Retaining plate (High clutch) | (20) Thrust needle bearing |
| (7) High clutch piston | (14) Snap ring | (21) High clutch hub |

General Description

AUTOMATIC TRANSMISSION

6. PLANETARY GEAR AND 2-4 BRAKE

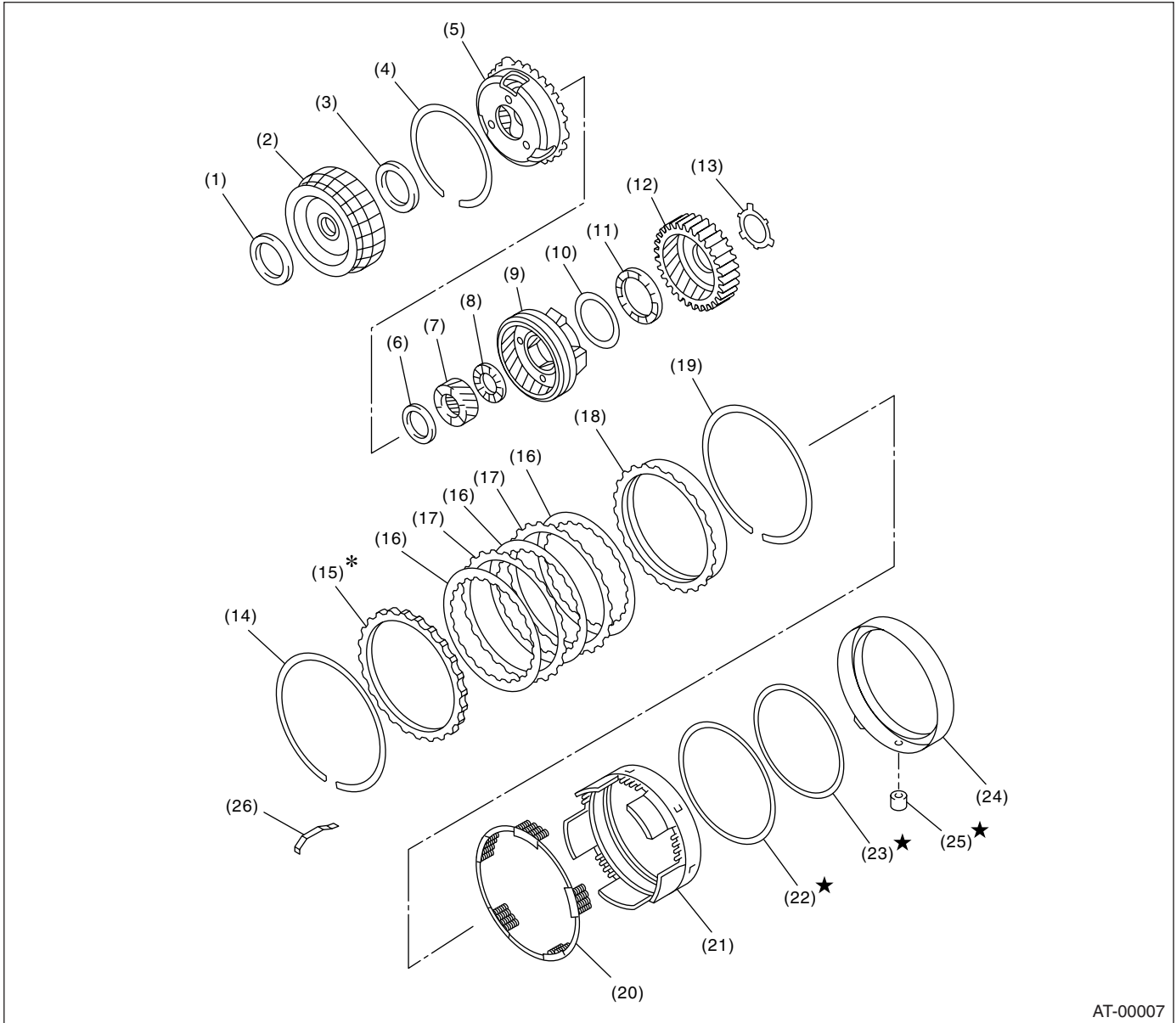

AT-00007

- | | | |
|-----------------------------|----------------------------|--------------------------------|
| (1) Thrust needle bearing | (10) Washer | (19) Snap ring |
| (2) Front sun gear | (11) Thrust needle bearing | (20) Spring retainer |
| (3) Thrust needle bearing | (12) Rear internal gear | (21) 2-4 brake piston |
| (4) Snap ring | (13) Washer | (22) D-ring |
| (5) Front planetary carrier | (14) Snap ring | (23) D-ring |
| (6) Thrust needle bearing | (15) Retaining plate | (24) 2-4 brake piston retainer |
| (7) Rear sun gear | (16) Drive plate | (25) 2-4 brake seal |
| (8) Thrust needle bearing | (17) Driven plate | (26) Leaf spring |
| (9) Rear planetary carrier | (18) Pressure rear plate | |

7. LOW CLUTCH AND LOW & REVERSE BRAKE

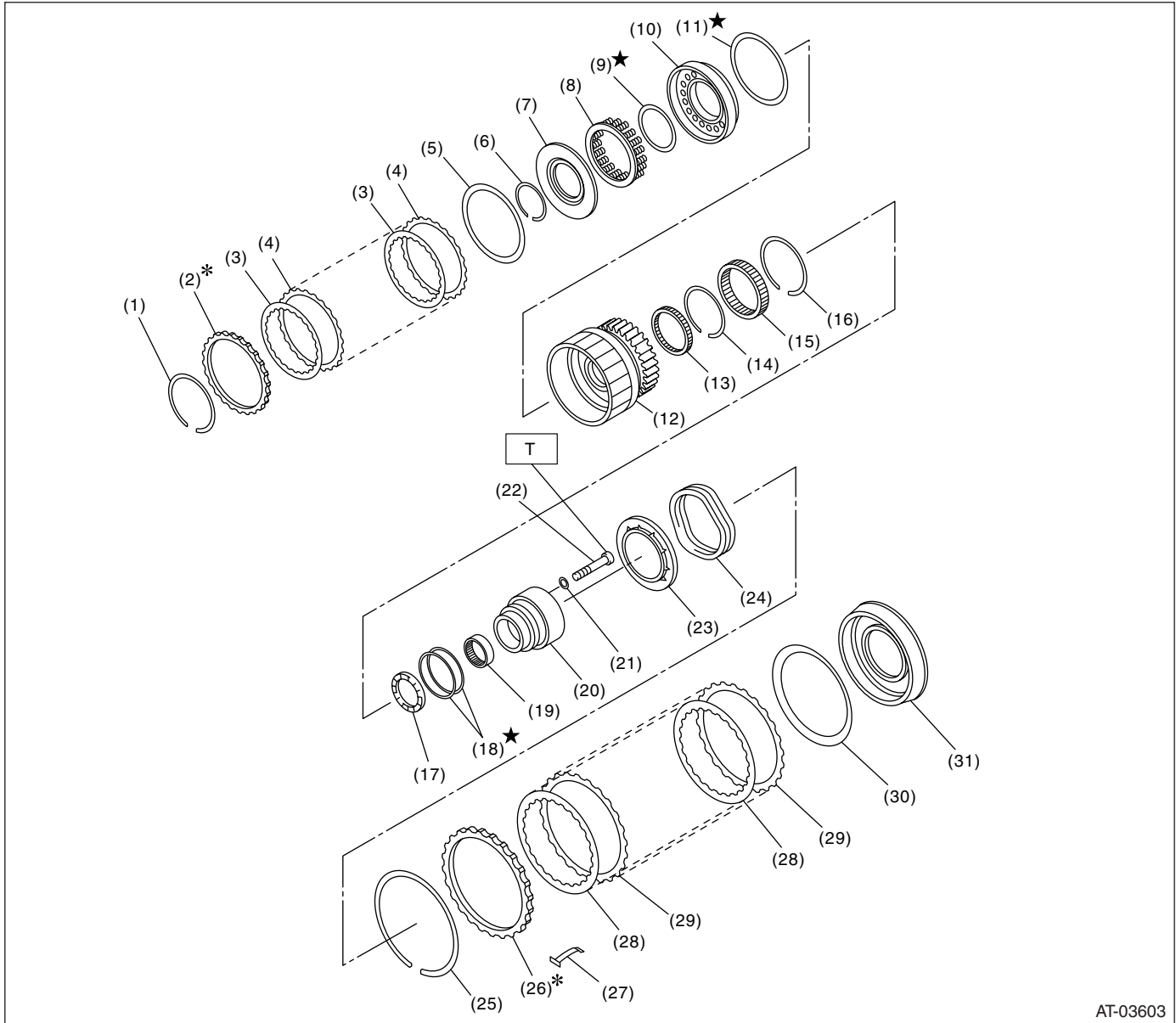

AT-03603

- | | | |
|------------------------|--------------------------------|---------------------------------|
| (1) Snap ring | (13) Needle bearing | (25) Snap ring |
| (2) Retaining plate | (14) Snap ring | (26) Retaining plate |
| (3) Drive plate | (15) One-way clutch | (27) Leaf spring |
| (4) Driven plate | (16) Snap ring | (28) Drive plate |
| (5) Dish plate | (17) Thrust needle bearing | (29) Driven plate |
| (6) Snap ring | (18) Seal ring | (30) Dish plate |
| (7) Cover | (19) Needle bearing | (31) Low & reverse brake piston |
| (8) Spring retainer | (20) One-way clutch inner race | |
| (9) D-ring | (21) Washer | |
| (10) Low clutch piston | (22) Socket bolt | |
| (11) D-ring | (23) Spring retainer | |
| (12) Low clutch drum | (24) Return spring | |

Tightening torque: N-m (kgf-m, ft-lb)

T: 25 (2.5, 18.4)

General Description

AUTOMATIC TRANSMISSION

8. REDUCTION GEAR WITH MP-T

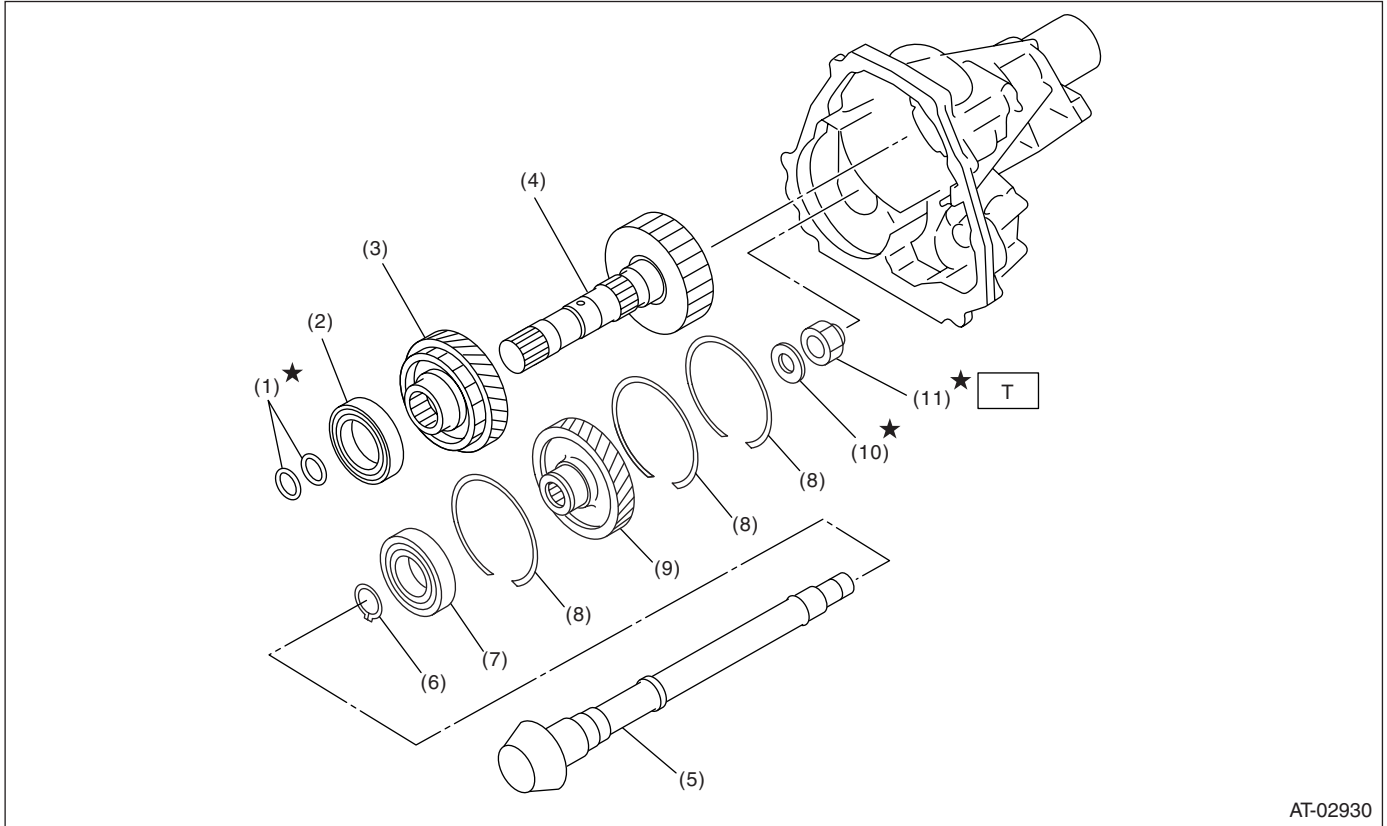

AT-02930

- (1) Seal ring
- (2) Ball bearing
- (3) Reduction drive gear
- (4) Reduction drive shaft
- (5) Drive pinion shaft

- (6) Snap ring
- (7) Ball bearing
- (8) Snap ring
- (9) Reduction driven gear
- (10) Washer

- (11) Lock nut

Tightening torque: N·m (kgf·m, ft·lb)

T: 100 (10.2, 73.8)

9. REDUCTION GEAR WITH VTD

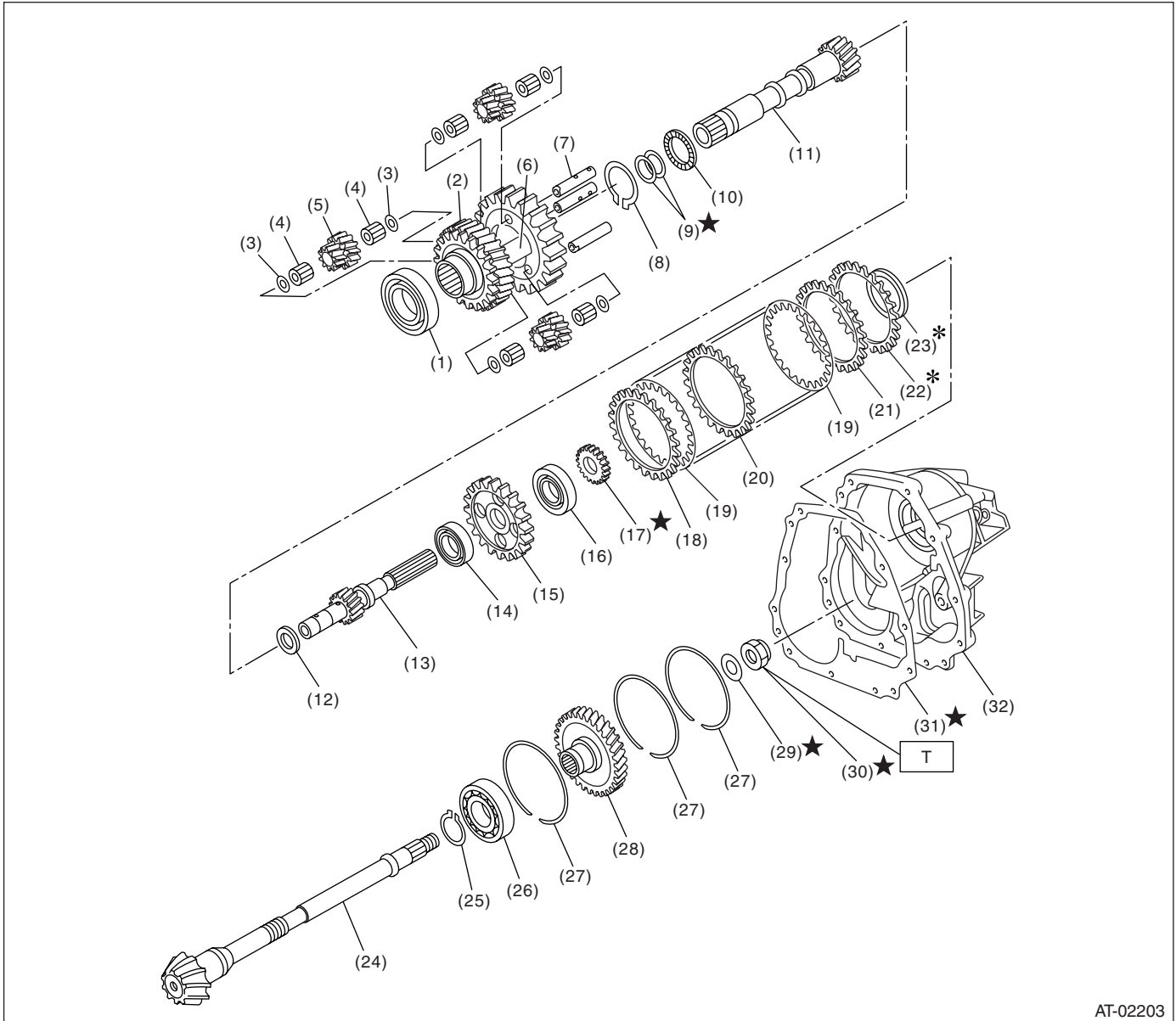

AT-02203

- | | | |
|----------------------------|-----------------------------------|----------------------------|
| (1) Ball bearing | (13) Rear drive shaft | (25) Snap ring |
| (2) Reduction drive gear | (14) Ball bearing | (26) Ball bearing |
| (3) Washer | (15) Multi-plate clutch (LSD) hub | (27) Snap ring |
| (4) Needle bearing | (16) Ball bearing | (28) Reduction driven gear |
| (5) Pinion gear | (17) Revolution gear | (29) Lock washer |
| (6) Carrier | (18) Driven plate (Thick) | (30) Lock nut |
| (7) Planetary pinion shaft | (19) Drive plate | (31) Gasket |
| (8) Snap ring | (20) Driven plate (Thin) | (32) Extension case |
| (9) Seal ring | (21) Driven plate (Thick) | |
| (10) Thrust needle bearing | (22) Retaining plate | |
| (11) Intermediate shaft | (23) Rear drive shaft shim | |
| (12) Thrust washer | (24) Drive pinion shaft | |

Tightening torque: N·m (kgf·m, ft·lb)

T: 100 (10.2, 73.8)

General Description

AUTOMATIC TRANSMISSION

10. DIFFERENTIAL GEAR

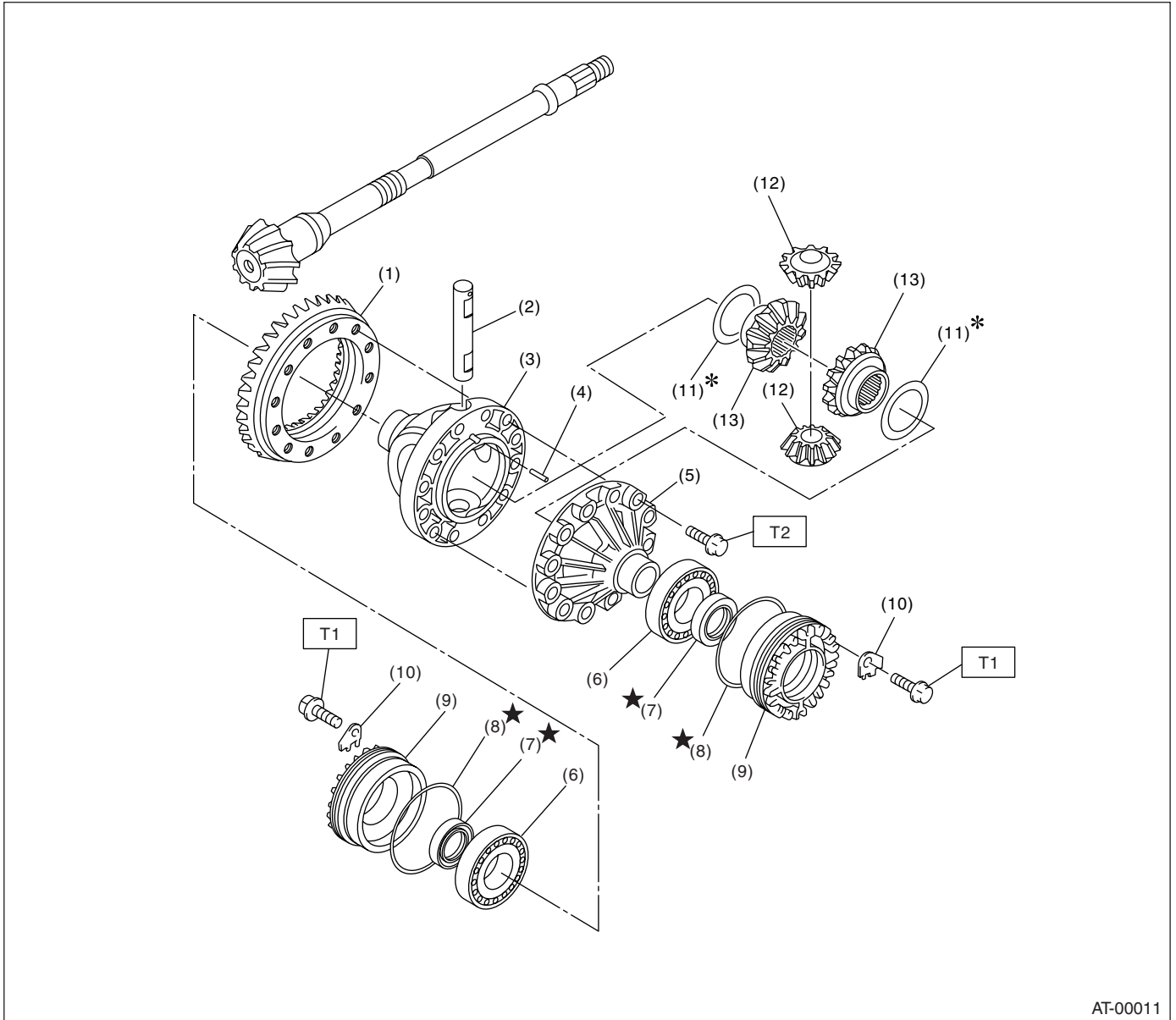

AT-00011

- | | | |
|----------------------------|--------------------------------|------------------------------|
| (1) Hypoid driven gear | (7) Oil seal | (13) Differential bevel gear |
| (2) Pinion shaft | (8) O-ring | |
| (3) Differential case (RH) | (9) Differential side retainer | |
| (4) Straight pin | (10) Lock plate | |
| (5) Differential case (LH) | (11) Washer | |
| (6) Taper roller bearing | (12) Differential bevel pinion | |

Tightening torque: N·m (kgf·m, ft·lb)

T1: 25 (2.5, 18.4)

T2: 62 (6.3, 45.7)

11. TRANSFER AND EXTENSION CASE WITH MP-T

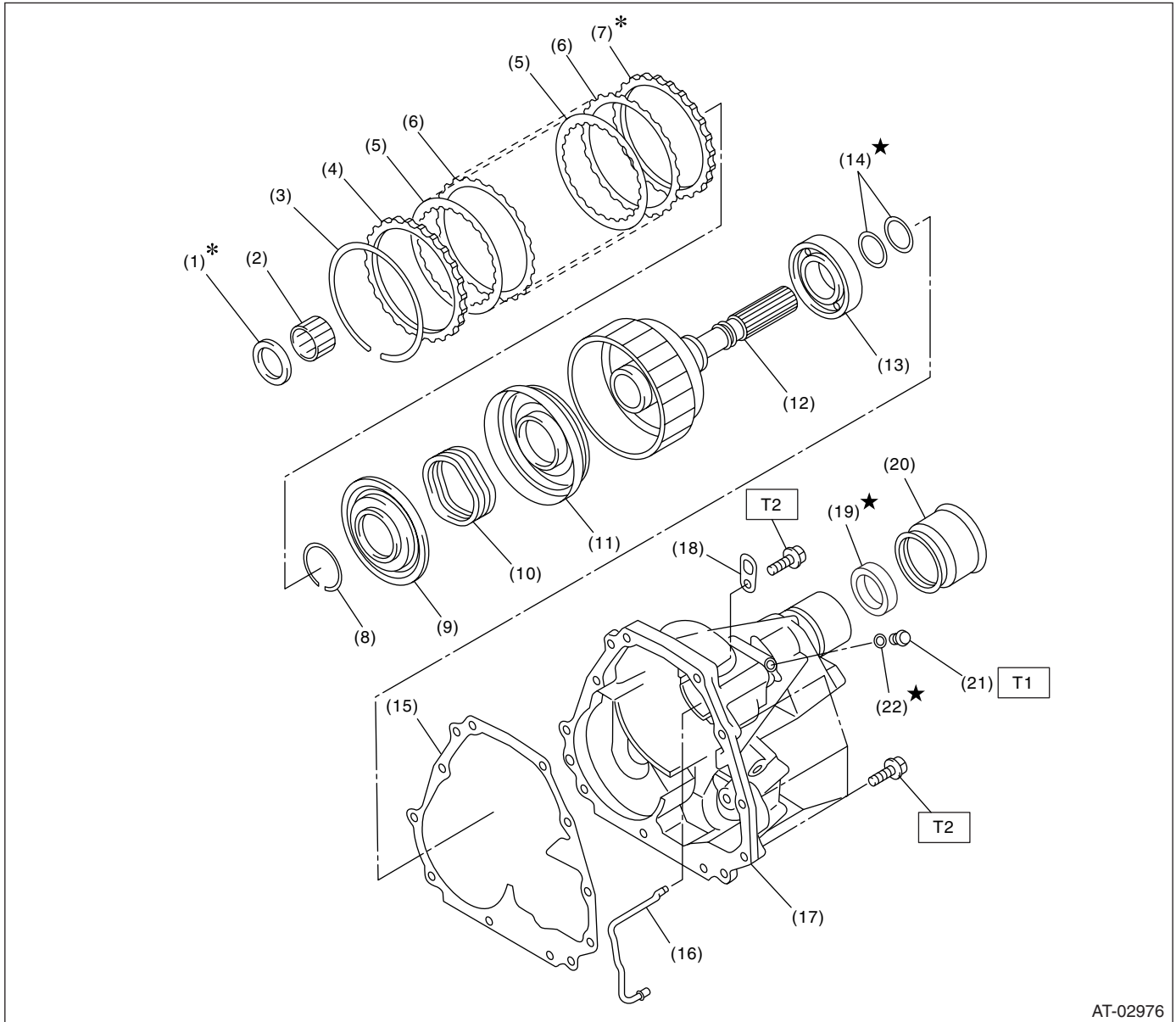

AT-02976

- | | | |
|---------------------------------|-----------------------------|----------------|
| (1) Thrust needle bearing | (11) Transfer clutch piston | (21) Test plug |
| (2) Needle bearing | (12) Rear drive shaft | (22) O-ring |
| (3) Snap ring | (13) Ball bearing | |
| (4) Driven plate (Thick) | (14) Seal ring | |
| (5) Drive plate | (15) Gasket | |
| (6) Driven plate (Thin) | (16) Transfer clutch pipe | |
| (7) Retaining plate | (17) Extension case | |
| (8) Snap ring | (18) Transmission hanger | |
| (9) Transfer clutch piston seal | (19) Oil seal | |
| (10) Return spring | (20) Dust cover | |
| | | (21) Test plug |
| | | (22) O-ring |

Tightening torque: N·m (kgf·m, ft·lb)

T1: 13 (1.3, 9.6)

T2: 25 (2.5, 18.4)

General Description

AUTOMATIC TRANSMISSION

12. TRANSFER AND EXTENSION CASE WITH VTD

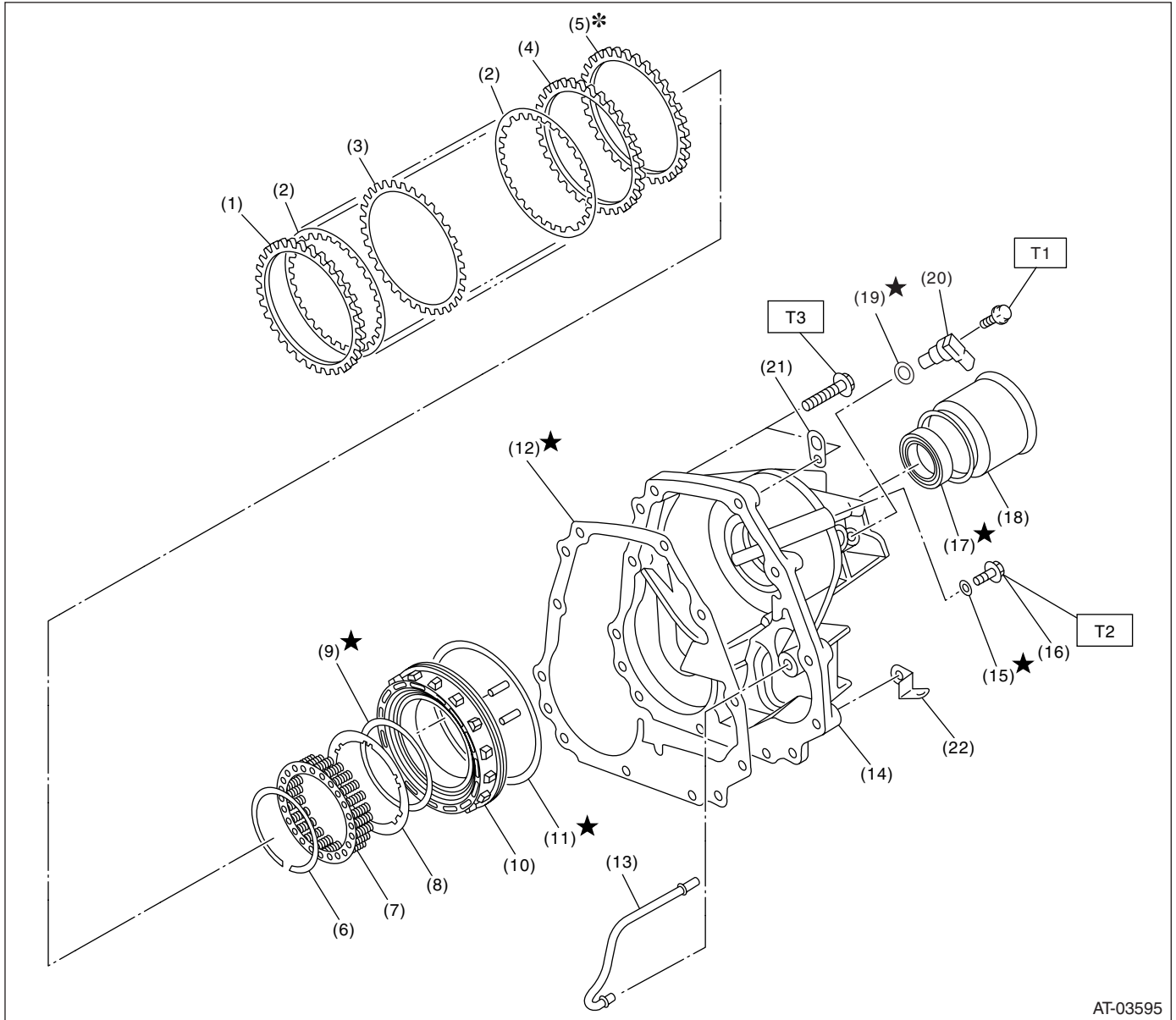

AT-03595

- | | | |
|--------------------------|--------------------------------------|--------------------------------|
| (1) Driven plate (Thick) | (10) Multi-plate clutch (LSD) piston | (19) O-ring |
| (2) Drive plate | (11) D-ring | (20) Rear vehicle speed sensor |
| (3) Driven plate (Thin) | (12) Gasket | (21) Transmission hanger |
| (4) Driven plate (Thick) | (13) Multi-plate clutch (LSD) pipe | (22) Harness bracket |
| (5) Retaining plate | (14) Extension case | |
| (6) Snap ring | (15) O-ring | |
| (7) Spring retainer | (16) Test plug | |
| (8) Plate | (17) Oil seal | |
| (9) O-ring | (18) Dust cover | |

Tightening torque: N·m (kgf·m, ft·lb)

T1: 7 (0.7, 5.1)

T2: 13 (1.3, 9.6)

T3: 25 (2.5, 18.4)

13. TRANSMISSION MOUNTING

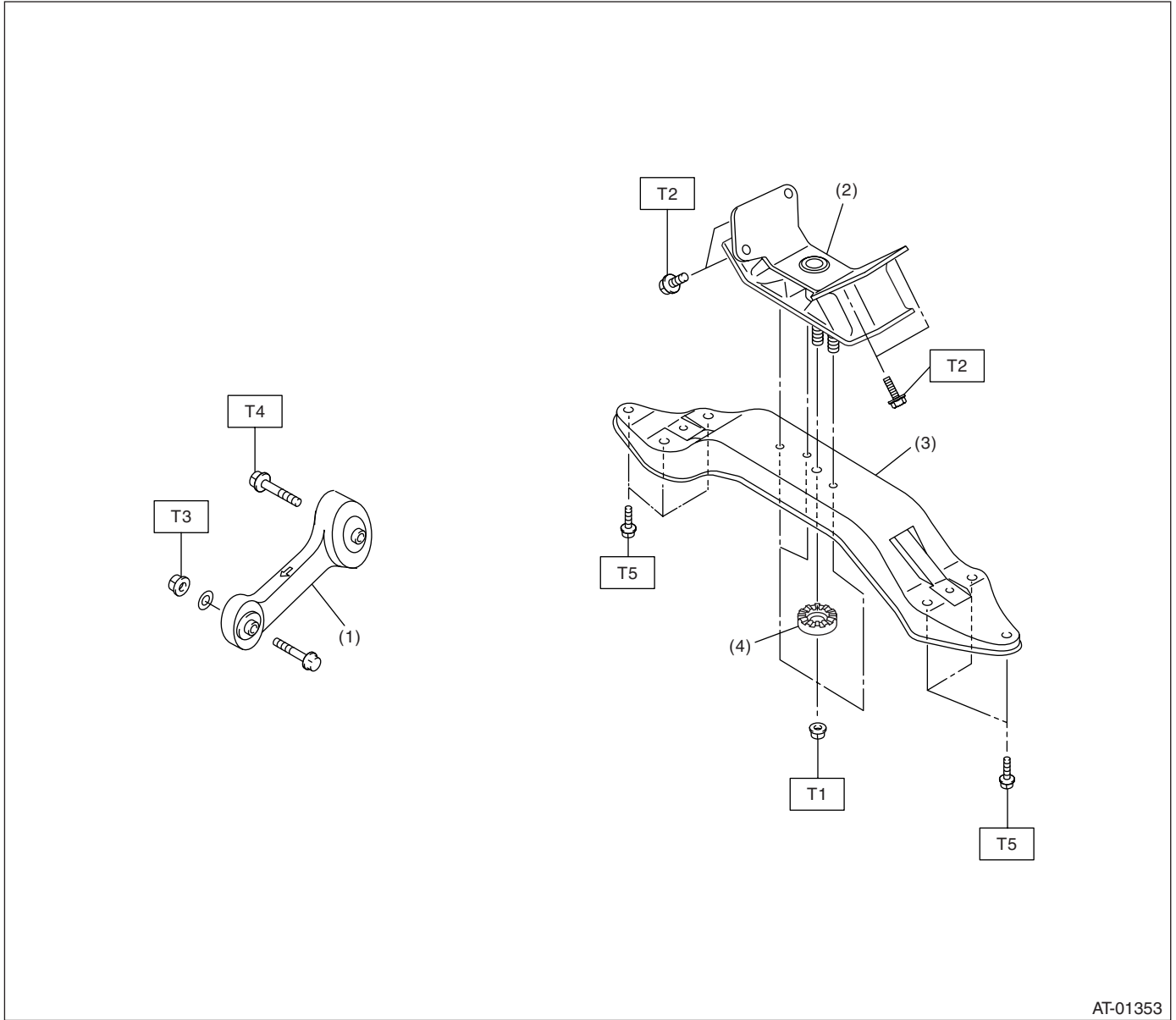

AT-01353

- (1) Pitching stopper
- (2) Rear cushion rubber
- (3) Transmission rear crossmember
- (4) Stopper

Tightening torque: N·m (kgf·m, ft·lb)

T1: 35 (3.6, 26)

T2: 39 (4.0, 29)

T3: 50 (5.1, 36.9)

T4: 58 (5.9, 43)

T5: 70 (7.1, 51.6)

C: CAUTION

- Wear work clothing, including a cap, protective goggles and protective shoes during operation.
- Remove contamination including dirt and corrosion before removal, installation, and disassembly.
- Keep the disassembled parts in order and protect them from dust and dirt.
- Do not place the oil pan with its inner side facing upward until it is installed so as to prevent foreign matter intrusion into valve body.
- Before removal, installation or disassembly, be sure to clarify the failure. Avoid unnecessary removal, installation, disassembly and replacement.
- When disassembling the case and other light alloy parts, use a plastic hammer to open. Do not pry it apart with a screwdriver or other tool.
- Be careful not to burn yourself, because each part on the vehicle is hot after running.
- Use genuine gear oil, grease etc. or the equivalent. Do not mix gear oil, grease etc. with that of another grade or from other manufacturers.
- Be sure to tighten fasteners including bolts and nuts to the specified torque.
- Place shop jacks or rigid racks at the specified points.
- Apply ATF or gear oil onto sliding or revolution surfaces before installation in view of components usage.
- Replace deformed or otherwise damaged snap rings with new ones.
- Before installing O-rings or oil seals, apply sufficient amount of ATF to avoid damage and deformation.
- Be careful not to incorrectly install or fail to install O-rings, snap rings and other such parts.
- Before securing a part on a vise, place cushioning material such as wood blocks, aluminum plate, or shop cloth between the part and the vise.
- Avoid damaging the mating surface of the case.
- Before applying liquid gasket, completely remove the old seal.
- When disassembling AT, be sure to use nylon or paper towel, do not use cloth glove and cloth.

D: PREPARATION TOOL

1. SPECIAL TOOL

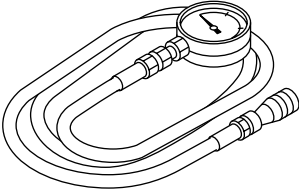
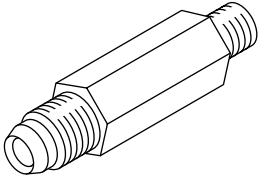
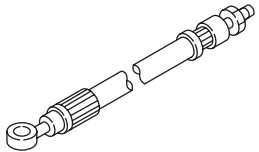
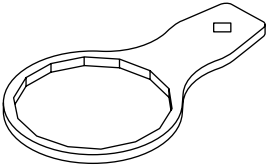
ILLUSTRATION	TOOL NUMBER	DESCRIPTION	REMARKS
 <p style="text-align: center;">ST-498575400</p>	498575400	OIL PRESSURE GAUGE ASSY	Used for measuring oil pressure.
 <p style="text-align: center;">ST-498897200</p>	498897200	OIL PRESSURE GAUGE ADAPTER	Used oil pump housing when measuring reverse clutch pressure and line pressure.
 <p style="text-align: center;">ST-498897700</p>	498897700	OIL PRESSURE ADAPTER SET	Used for measuring transfer clutch pressure.
 <p style="text-align: center;">ST-498545400</p>	498545400	OIL FILTER WRENCH	Used for removing and installing ATF filter.

General Description

AUTOMATIC TRANSMISSION

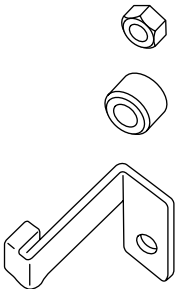
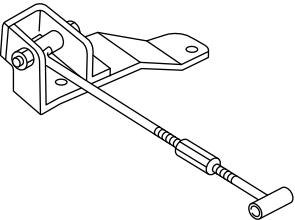
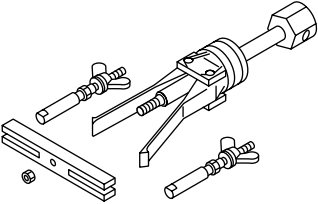
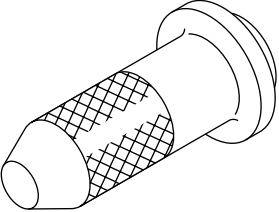
ILLUSTRATION	TOOL NUMBER	DESCRIPTION	REMARKS
 <p style="text-align: center;">ST-498277200</p>	498277200	STOPPER SET	Used for removing and installing automatic transmission assembly to engine.
 <p style="text-align: center;">ST41099AC000</p>	41099AC000	ENGINE SUPPORT ASSY	Used for supporting engine.
 <p style="text-align: center;">ST-398527700</p>	398527700	PULLER ASSY	<ul style="list-style-type: none"> • Used for removing extension case roller bearing. • Used for removing extension oil seal. • Used for removing front differential side retainer bearing outer race. • Used for removing front differential side retainer bearing outer ball race.
 <p style="text-align: center;">ST-498057300</p>	498057300	INSTALLER	Used for installing extension oil seal.

General Description

AUTOMATIC TRANSMISSION

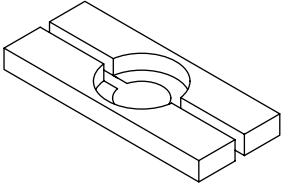
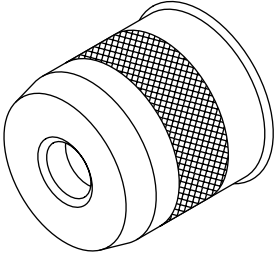
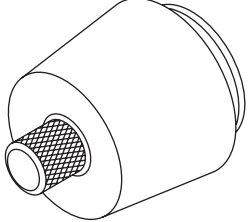
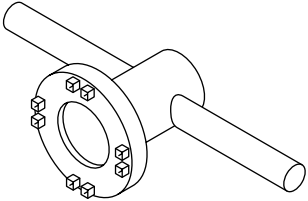
ILLUSTRATION	TOOL NUMBER	DESCRIPTION	REMARKS
 <p>ST-498077000</p>	498077000	REMOVER	Used for removing differential taper roller bearing.
 <p>ST-499247400</p>	499247400	INSTALLER	<ul style="list-style-type: none"> • Used for installing transfer outer snap ring. • Used with SNAP RING OUTER GUIDE (499257300).
 <p>ST-499257300</p>	499257300	SNAP RING OUTER GUIDE	<ul style="list-style-type: none"> • Used for installing transfer outer snap ring. • Used with INSTALLER (499247400).
 <p>ST-499787000</p>	499787000	WRENCH ASSY	Used for removing and installing differential side retainer.

General Description

AUTOMATIC TRANSMISSION

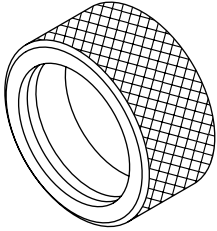
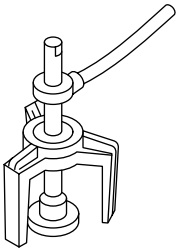
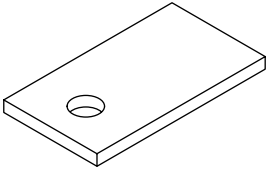
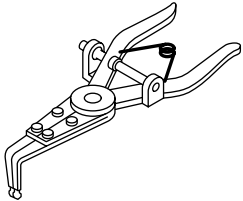
ILLUSTRATION	TOOL NUMBER	DESCRIPTION	REMARKS
 <p style="text-align: center;">ST-398437700</p>	398437700	DRIFT	<ul style="list-style-type: none"> • Used for installing converter case oil seal. • Used for installing taper roller bearing of front differential.
 <p style="text-align: center;">ST-398673600</p>	398673600	COMPRESSOR	Used for removing and installing clutch spring.
 <p style="text-align: center;">ST-498255400</p>	498255400	PLATE	Used for measuring backlash of hypoid gear.
 <p style="text-align: center;">ST-399893600</p>	399893600	PLIERS	Used for removing and installing clutch spring.

General Description

AUTOMATIC TRANSMISSION

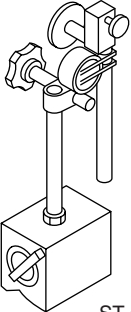
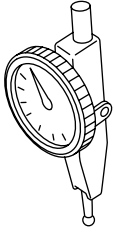
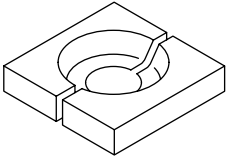
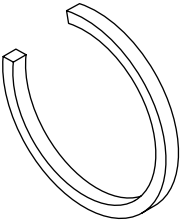
ILLUSTRATION	TOOL NUMBER	DESCRIPTION	REMARKS
 <p>ST-498247001</p>	498247001	MAGNET BASE	<ul style="list-style-type: none"> • Used for measuring gear backlash. • Used with DIAL GAUGE (498247100).
 <p>ST-498247100</p>	498247100	DIAL GAUGE	<ul style="list-style-type: none"> • Used for measuring gear backlash. • Used with MAGNET BASE (498247001).
 <p>ST-498517000</p>	498517000	REPLACER	Used for removing front roller bearing.
 <p>ST-398623600</p>	398623600	SEAT	Used for removing spring of transfer clutch piston.

General Description

AUTOMATIC TRANSMISSION

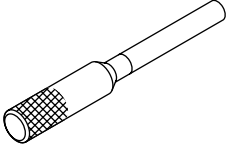
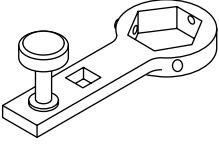
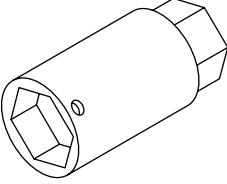
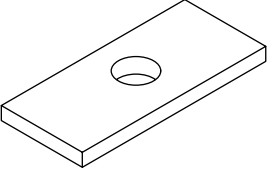
ILLUSTRATION	TOOL NUMBER	DESCRIPTION	REMARKS
 <p style="text-align: center;">ST-499267300</p>	499267300	STOPPER PIN	Used for installing inhibitor switch.
 <p style="text-align: center;">ST-499787700</p>	499787700	WRENCH	Used for removing and installing drive pinion lock nut.
 <p style="text-align: center;">ST-499787500</p>	499787500	ADAPTER	Used for removing and installing drive pinion lock nut.
 <p style="text-align: center;">ST-398643600</p>	398643600	GAUGE	Used for measuring total end play, extension end play and drive pinion height.

General Description

AUTOMATIC TRANSMISSION

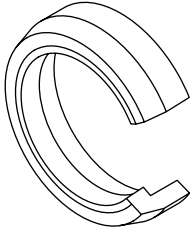
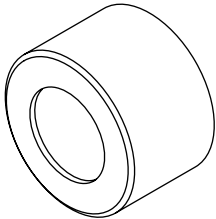
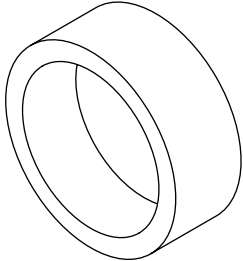
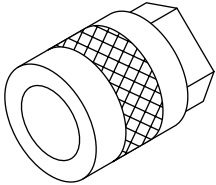
ILLUSTRATION	TOOL NUMBER	DESCRIPTION	REMARKS
 <p style="text-align: center;">ST-498627100</p>	498627100	SEAT	Used for holding low clutch piston retainer spring when installing snap ring.
 <p style="text-align: center;">ST-499577000</p>	499577000	GAUGE	<ul style="list-style-type: none"> • Used for measuring the transmission case mating surface to the reduction gear end surface. • For MP-T model.
 <p style="text-align: center;">ST-398744300</p>	398744300	GAUGE	<ul style="list-style-type: none"> • Use for measuring contact face between multi-plate clutch end and transmission. • For VTD model.
 <p style="text-align: center;">ST-499737000</p>	499737000	PULLER	Used for removing reduction driven gear assembly.

General Description

AUTOMATIC TRANSMISSION

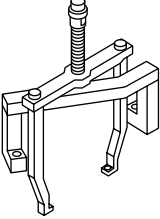
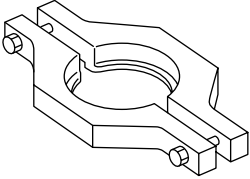
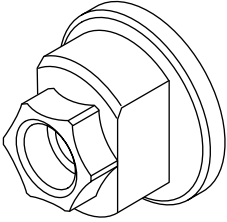
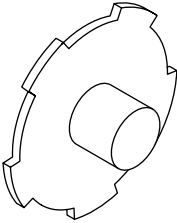
ILLUSTRATION	TOOL NUMBER	DESCRIPTION	REMARKS
 <p style="text-align: center;">ST-499737100</p>	499737100	PULLER SET	Used for removing reduction drive gear assembly.
 <p style="text-align: center;">ST-498077600</p>	498077600	REMOVER	Used for removing ball bearing.
 <p style="text-align: center;">ST-498937110</p>	498937110	HOLDER	Used for removing and installing drive pinion lock nut.
 <p style="text-align: center;">ST-498677100</p>	498677100	COMPRESSOR	Used for installing 2-4 brake snap ring.

General Description

AUTOMATIC TRANSMISSION

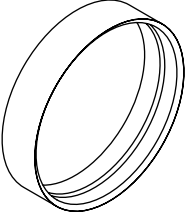
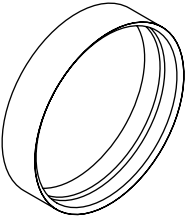
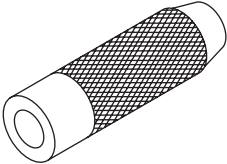
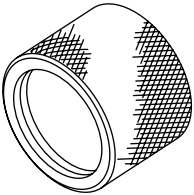
ILLUSTRATION	TOOL NUMBER	DESCRIPTION	REMARKS
 <p data-bbox="337 537 467 558">ST-498437000</p>	498437000	HIGH CLUTCH PISTON GUIDE	Used for installing high clutch piston.
 <p data-bbox="337 911 467 932">ST-498437100</p>	498437100	LOW CLUTCH PISTON GUIDE	Used for installing low clutch piston.
 <p data-bbox="337 1285 467 1306">ST-899580100</p>	899580100	INSTALLER	Used for press-fitting the ball bearing for transfer clutch.
 <p data-bbox="326 1659 467 1680">ST18675AA000</p>	18675AA000	DIFFERENTIAL SIDE OIL SEAL INSTALLER	Used for installing differential side retainer oil seal.

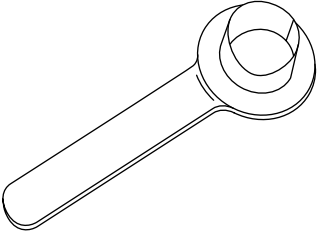
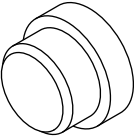
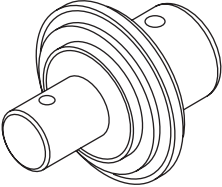
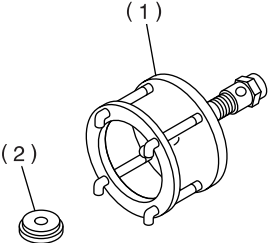

General Description

AUTOMATIC TRANSMISSION

ILLUSTRATION	TOOL NUMBER	DESCRIPTION	REMARKS
 <p style="text-align: center;">ST28399SA010</p>	28399SA010	OIL SEAL PROTECTOR	Used for installing front drive shaft.
 <p style="text-align: center;">ST-398497701</p>	398497701	INSTALLER	Used for installing needle bearing.
 <p style="text-align: center;">ST-499247300</p>	499247300	INSTALLER	Used for installing drive pinion shaft oil seal.
 <p style="text-align: center;">ST-899524100</p>	899524100	PULLER SET	Used for bolt only. <ul style="list-style-type: none"> • Used with PULLER SET (499737100). • Used with PULLER (499737000). (1) Puller (2) Cap

General Description

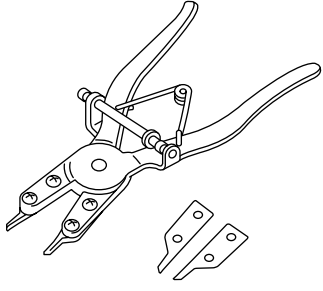
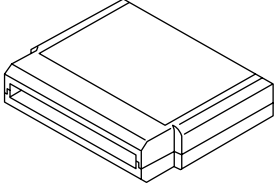
AUTOMATIC TRANSMISSION

ILLUSTRATION	TOOL NUMBER	DESCRIPTION	REMARKS
 <p>ST-398663600</p>	398663600	PLIERS	Used for removing and installing snap ring.
 <p>ST18482AA010</p>	18482AA010 (Newly adopted tool)	CARTRIDGE	Troubleshooting for electrical systems.
 <p>ST22771AA030</p>	22771AA030	SUBARU SELECT MONITOR KIT	Troubleshooting for electrical systems.

2. GENERAL TOOL

TOOL NAME	REMARKS
Depth gauge	Used for measuring transmission end play.
Thickness gauge	Used for measuring clearances of clutch, brake and oil pump.
Micro meter	Used for measuring thickness of drive pinion.
Spring balance	Used for measuring starting torque of drive pinion.
Circuit tester	Used for measuring resistance and voltage.
TORX® T70	Used for removing and installing differential gear oil drain plug.
Push/pull gauge	Used for measuring low & reverse and high clutch piston stroke.

2. Automatic Transmission Fluid

A: INSPECTION

NOTE:

The level of ATF varies with fluid temperature. Pay attention to the fluid temperature when checking ATF level.

1) Raise the ATF temperature by driving a distance of 5 to 10 km (3 to 6 miles). Otherwise, idle the engine to raise ATF temperature to 70 — 80°C (158 — 176°F) on SUBARU Select Monitor.

<Ref. to 4AT(D)(diag)-13, READ CURRENT DATA, OPERATION, Subaru Select Monitor.>

2) Make sure the vehicle is level.

3) After selecting all positions (P, R, N, D, 3, 2, 1), set the select lever in “P” range. Measure the ATF level with the engine idling for one or two minutes.

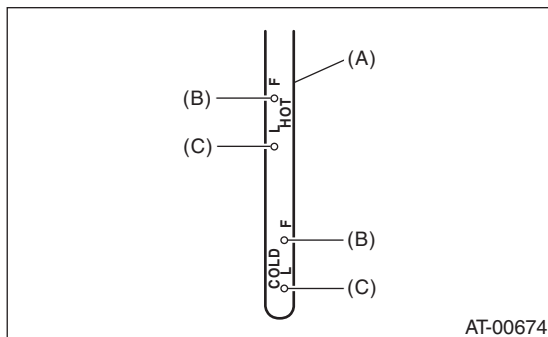

- (A) ATF level gauge
- (B) Upper level
- (C) Lower level

4) Make sure that ATF level is between the upper level and lower level at HOT side.

If the level is below the lower level, check for leaks in the transmission. If there are leaks, it is necessary to repair or replace gasket, oil seals, plugs or other parts.

CAUTION:

- Use care not to exceed the upper limit level.
- Filling of ATF to the upper level when the transmission is cold will result in overfilling of ATF, causing a transmission failure.

5) Check ATF level after raising ATF temperature to 70 — 80°C (158 — 176°F) by driving the distance of 5 to 10 km (3 to 6 miles) or by idling the engine.

B: REPLACEMENT

- 1) Lift-up the vehicle.
- 2) Drain the ATF completely.
- 3) Check the ATF for condition. <Ref. to 4AT-31, CONDITION CHECK, Automatic Transmission Fluid.>

CAUTION:

Directly after the vehicle has been running, the ATF is hot. Therefore, be careful not to burn yourself.

4) Replace with a new gasket, and then tighten the ATF drain plug.

Tightening torque:

25 N·m (2.5 kgf-m, 18.4 ft-lb)

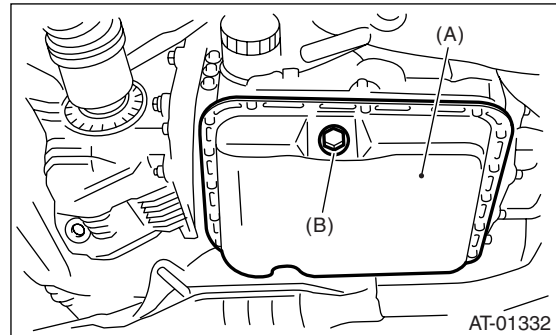

- (A) Oil pan
- (B) Drain plug (ATF)

5) Lower the vehicle.

6) Pour ATF through the oil charge pipe.

Recommended fluid:

<Ref. to RM-4, FLUID, RECOMMENDED MATERIALS, Recommended Materials.>

Fluid capacity:

Fill the same amount of ATF drained from drain plug hole.

Capacity when transmission is overhauled:

9.3 — 9.6 ℓ (9.8 — 10.1 US qt, 8.2 — 8.4 Imp qt)

7) Check the level and leaks of ATF.

<Ref. to 4AT-30, INSPECTION, Automatic Transmission Fluid.>

C: CONDITION CHECK

NOTE:

When replacing ATF, check the inside condition of the transmission body by inspecting the drained ATF.

Fluid condition	Trouble and possible cause	Corrective action
Large amount of metallic pieces are found.	Excessive wear of the internal of the transmission body.	Replace ATF and check if AT operates correctly.
Thick and varnish-form fluid.	Burned clutch and etc.	Replace ATF and check AT itself and vehicle for faulty.
Clouded fluid or bubbles are found in fluid.	Water mixed in fluid.	Replace ATF and check the water entering point.

Differential Gear Oil

AUTOMATIC TRANSMISSION

3. Differential Gear Oil

A: INSPECTION

- 1) Park the vehicle on a level surface.
- 2) Remove the oil level gauge and wipe it clean.
- 3) Reinsert the level gauge all the way. Be sure that the level gauge is correctly inserted and in the proper orientation.
- 4) Remove it again and check the level. If the differential gear oil level is below the "L" line, add oil to bring the level up to the "F" line.
- 5) To prevent overfilling the differential gear oil, do not replenish oil above the "F" line.

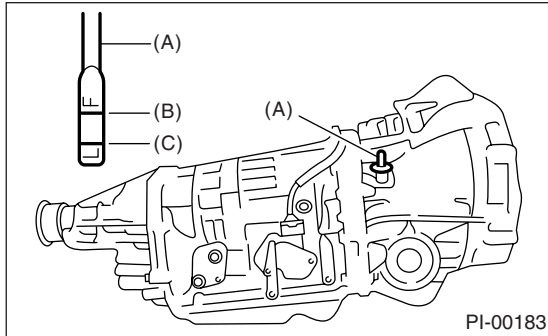

- (A) Oil level gauge
- (B) Upper level
- (C) Lower level

B: REPLACEMENT

- 1) Lift-up the vehicle.
- 2) Remove the differential gear oil drain plug using TORX® T70, and then drain the differential gear oil completely.

CAUTION:

- Directly after the vehicle has been running, the differential gear oil is hot. Therefore, be careful not to burn yourself.
 - Be careful not to spill the differential gear oil on exhaust pipe to prevent it from emitting smoke or fire. When the differential gear oil is spilled on exhaust pipe, wipe it away completely.
- 3) Replace the gasket with a new one, and then tighten the differential gear oil drain plug using TORX® T70.

Tightening torque:

44 N·m (4.5 kgf-m, 32.5 ft-lb) (Aluminum gasket)

70 N·m (7.1 kgf-m, 51.6 ft-lb) (Copper gasket)

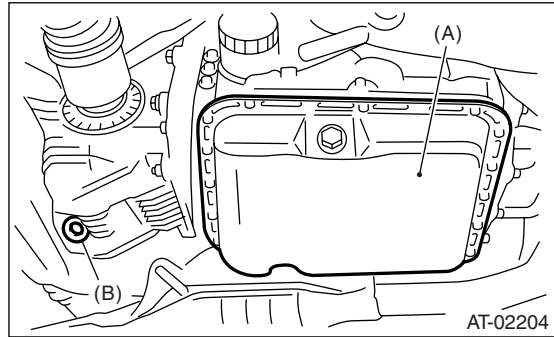

- (A) Oil pan
- (B) Differential oil drain plug

- 4) Lower the vehicle.
- 5) Pour gear oil into the gauge hole.

Recommended fluid:

<Ref. to 4AT-3, HYDRAULIC CONTROL AND LUBRICATION, SPECIFICATION, General Description.>

Gear oil capacity:

1.1 — 1.3 ℓ (1.2 — 1.4 US qt, 1.0 — 1.1 Imp qt)

- 6) Check the level of differential gear oil.
<Ref. to 4AT-32, INSPECTION, Differential Gear Oil.>

4. Road Test

A: INSPECTION

1. GENERAL PRECAUTION

Road tests should be conducted to properly diagnose the condition of the automatic transmission.

NOTE:

When performing the test, do not exceed posted speed limit.

2. D RANGE SHIFT FUNCTION

Check shifting between 1st ↔ 2nd ↔ 3rd ↔ 4th while driving on normal city streets.

3. D RANGE SHIFT SHOCK

Check the shock level when shifting up during normal driving.

4. KICK-DOWN FUNCTION

Check kick-down for each gear. Also check the kick-down shock level.

5. ENGINE BRAKE OPERATION

- Check the 3rd gear engine brake when shifting between D ↔ 3rd range while driving in 4th gear of D range [50 to 60 km/h (31 to 37 MPH)].
- Check the 2nd gear engine brake when shifting between 3 ↔ 2 range while driving in the 3 range 3rd gear [40 to 50 km/h (25 to 31 MPH)].
- Check the 1st gear engine brake when shifting between 2 ↔ 1 range while driving in the 2 range 2nd gear [20 to 30 km/h (12 to 19 MPH)].

6. LOCK-UP FUNCTION

- Check that engine speed does not change sharply when the accelerator pedal is lightly depressed when driving on flat roads at normal speed in the D range.
- Check slip lock-up with following procedures. Subaru Select Monitor is needed for checking. Before start checking, check that no DTC is displayed. Perform the collective action with DTC and make sure that no more DTC is displayed, and then start the checking.

1) Perform the check on flat and straight road or free roller.

NOTE:

- Slip lock-up does not operate when the vehicle is lifted up, because of not occurring surface resistance.
- Also when checking on the free roller, check with depressing the foot brake lightly to make the checking easier, because the surface resistance will be deficient.

2) Connect the Subaru Select Monitor.

3) Check the ATF temperature using Subaru Select Monitor.

NOTE:

- ATF temperature is between 50 — 100°C (122 — 212°F)
 - When the temperature is low, warm-up the ATF by running the vehicle or etc.
- 4) Start the engine, so that the lock-up duty can be read on data display of Subaru Select Monitor.
- 5) Drive the vehicle at a constant speed of 35 — 40 km/h (22 — 25 MPH).
- 6) Read the lock-up duty while vehicle is running.

Standard value:

25 — 45%

NOTE:

The value may be lower on the free roller.

- Slip lock-up control is not operating when the lock-up duty is less than 5%, or when the lock-up duty goes down immediately after starts rising. On these cases, improper ATF or deterioration of ATF may be the cause. Check the amount of ATF or replace them, and then recheck it.

7. P RANGE OPERATION

Stop the vehicle on an uphill grade of 5% or more and shift to “P” range. Check that the vehicle does not move when the parking brake is released.

8. UNUSUAL SOUNDS AND VIBRATION

Check for unusual sounds and vibration while driving and during shifting.

9. CLIMBING CONTROL FUNCTION

- Check that the gear remains in 3rd when going up a grade.
- Check that the gear remains in 3rd when applying the brakes while going down a grade.

10. TRANSFER CLUTCH

Check if the tight corner braking occurs when the vehicle is started with steering wheel held at fully turned position.

11. OIL LEAKS

After the driving test, inspect for oil leaks.

Stall Test

AUTOMATIC TRANSMISSION

5. Stall Test

A: INSPECTION

NOTE:

The stall test is of extreme importance in diagnosing the condition of the automatic transmission and the engine. It should be conducted to measure the engine stall speeds in "R" and "2" ranges.

Purposes of the stall test:

- To check the operation of the automatic transmission clutch
- To check the operation of the torque converter clutch
- To check engine performance

- 1) Check that throttle valve opens fully.
- 2) Check that engine oil level is correct.
- 3) Check that engine coolant level is correct.
- 4) Check that ATF level is correct.
- 5) Check that differential gear oil level is correct.
- 6) Increase ATF temperature to 70 to 80°C (158 to 176°F) by idling the engine for approx. 30 minutes (with select lever set to "N" or "P").
- 7) Place the wheel chocks at the front and rear of all wheels and apply the parking brake.
- 8) Move the manual linkage to ensure it operates properly, and shift the select lever to the "2" range.
- 9) While depressing the foot brake pedal, gradually depress the accelerator pedal until the engine operates at full throttle.

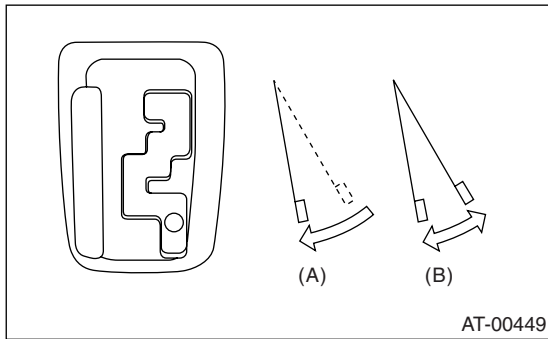

(A) Brake pedal
(B) Accelerator pedal

10) When the engine speed is stabilized, record that speed quickly and release the accelerator pedal.

11) Shift the select lever to "N" range, and cool down the engine by idling it for more than one minute.

12) If the stall speed in "2" range is higher than specifications, low clutch slipping and 2-4 brake slipping may occur. To identify it, conduct the same test as above in "R" range.

13) Perform the stall tests with the select lever in "D" range.

NOTE:

- Do not continue the stall test for MORE THAN 5 SECONDS at a time (from closed throttle, fully open throttle to stall speed reading). Failure to follow this instruction causes the engine oil and ATF to deteriorate and the clutch and brake to be adversely affected.
- Be sure to cool down the engine for at least 1 minute after each stall test with the select lever set in the "P" or "N" range and with the idle speed lower than 1,200 rpm.
- If the stall speed is higher than the specified range, attempt to finish the stall test in as short a time as possible, in order to prevent the automatic transmission from sustaining damage.

Stall speed (at sea level):

Non-turbo model:

2,200 — 2,700 rpm

Turbo model:

2,700 — 3,200 rpm

Stall speed (at sea level)	Position	Cause
Less than specifications	2, R	<ul style="list-style-type: none"> • Throttle valve not fully open • Erroneous engine operation • Torque converter clutch's one-way clutch slipping
Greater than specifications	D	<ul style="list-style-type: none"> • Line pressure too low • Low clutch slipping • One-way clutch malfunction
	R	<ul style="list-style-type: none"> • Line pressure too low • Reverse clutch slipping • Low & reverse brake slipping
	2	<ul style="list-style-type: none"> • Line pressure too low • Low clutch slipping • 2-4 brake slipping

6. Time Lag Test

A: INSPECTION

NOTE:

If the select lever is shifted while the engine is idling, there will be a certain time elapse or lag before the shock can be felt. This is used for checking the condition of the low clutch, reverse clutch, low & reverse brake and one-way clutch.

- Perform the test at normal operating fluid temperature 70 to 80°C (158 to 176°F).
- Be sure to allow a 1 minute interval between tests.
- Make three measurements and take the average value.

1) Apply the parking brake.

2) Start the engine.

Check the idling speed (A/C OFF).

3) Shift the select lever from "N" to "D" range.

Using a stop watch, measure the time it takes from shifting the lever until the shock is felt.

Time lag: Less than 1.2 seconds

If "N" → "D" time lag is longer than specified:

- Line pressure too low
- Low clutch worn
- One-way clutch not operating properly
- D-ring worn

4) In the same manner, measure the time lag for "N" → "R".

Time lag: Less than 1.5 seconds

If "N" → "R" time lag is longer than specified:

- Line pressure too low
- Reverse clutch worn
- Low & reverse brake worn
- D-ring worn

Line Pressure Test

AUTOMATIC TRANSMISSION

7. Line Pressure Test

A: MEASUREMENT

NOTE:

If the clutch or the brake shows a sign of slippage or shifting sensation is not correct, the line pressure should be checked.

- Excessive shocks during upshifting or shifting takes place at a higher point than under normal circumstances, may be due to the line pressure being too high.

- Slippage or inability to operate the vehicle may, in most cases, be due to loss of oil pressure for the operation of the clutch, brake or control valve.

- Line pressure measurement (under no load)
 - Before measuring the line pressure, lift-up the vehicle.
 - Maintain the temperature of ATF at approx. 70 — 80°C (158 — 176°F) during measurement. (ATF will reach the above temperature after idling the engine for approx. 30 minutes with select lever in “N” or “P”.)
- Line pressure measurement (under heavy load)
 - Before measuring the line pressure, apply both foot and parking brakes with all wheels chocked (Same as for “stall” test conditions).
 - Measure the line pressure when select lever is in “R” or “2” with engine under stall conditions.
 - Measure the line pressure within 5 seconds after shifting the select lever to each position. (If line pressure needs to be measured again, allow the engine to idle, and then stop it to cool down for at least one minute.)
 - Maintain the temperature of ATF at approx. 70 — 80°C (158 — 176°F) during measurement. (ATF will reach the above temperature after idling the engine for approx. 30 minutes with the select lever in “N” or “P”.)
- Temporarily attach the ST to a suitable place in the driver’s compartment, remove the blind plug located in front of the toe board and pass the hose of the ST to engine compartment.

ST 498575400 OIL PRESSURE GAUGE ASSY

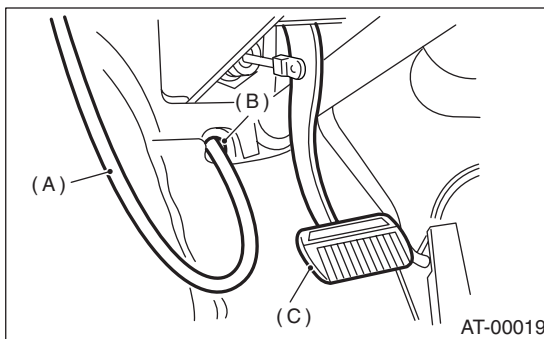

- (A) Pressure gauge hose
- (B) Hole in toe board (blank cap hole)
- (C) Brake pedal

4) Remove the test plug and install the ST instead.
ST 498897200 OIL PRESSURE GAUGE ADAPTER

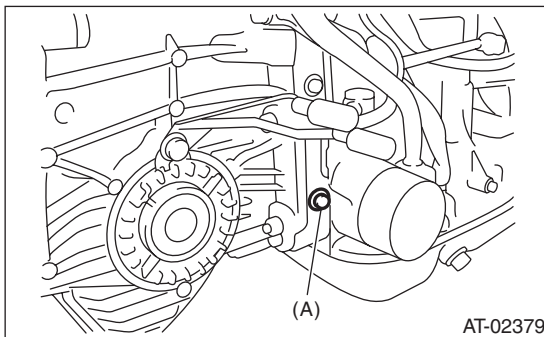

- (A) Test plug

5) Connect the ST1 with ST2.
ST1 498897200 OIL PRESSURE GAUGE ADAPTER
ST2 498575400 OIL PRESSURE GAUGE ASSY

6) Check for duty ratio changes by opening and closing the throttle valve using SUBARU Select Monitor.

Standard line pressure			
Range position	Line pressure duty ratio (%)	Throttle position	Line pressure kPa (kgf/cm ² , psi)
2	25 — 35	100 (Full open)	1,000 — 1,300 (10.2 — 13.3, 145 — 189)
R	15 — 25	100 (Full open)	1,500 — 1,850 (15.3 — 18.9, 218 — 268)
D	35 — 43	0 (Full closed)	500 — 800 (5.1 — 8.2, 73 — 116)

8. Transfer Clutch Pressure Test

A: INSPECTION

- MP-T model

Check the transfer clutch pressure in accordance with the following chart in the same manner as with line pressure. <Ref. to 4AT-36, Line Pressure Test.>

ST 498897700 OIL PRESSURE ADAPTER SET

ST 498575400 OIL PRESSURE GAUGE ASSY

AWD mode: "D" range

FWD mode: "P" range, engine speed 2,000 rpm

NOTE:

Before setting in FWD mode, install the spare fuse on FWD switch.

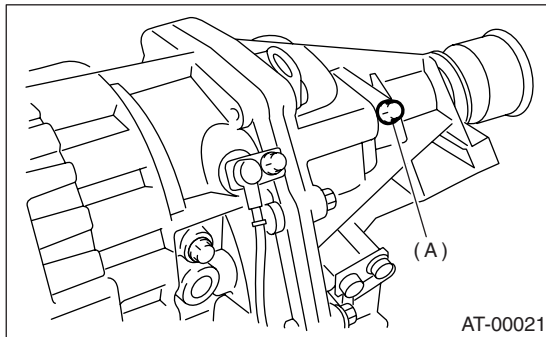

(A) Test plug

NOTE:

If the oil pressure is not produced or if it does not change in the AWD mode, the transfer duty solenoid or transfer valve assembly may be malfunctioning. If the oil pressure is produced in the FWD mode, the problem is similar to that in the AWD mode.

- VTD model

Check transfer clutch pressure using the following chart. <Ref. to 4AT-36, Line Pressure Test.>

ST 498897700 OIL PRESSURE ADAPTER SET

ST 498575400 OIL PRESSURE GAUGE ASSY

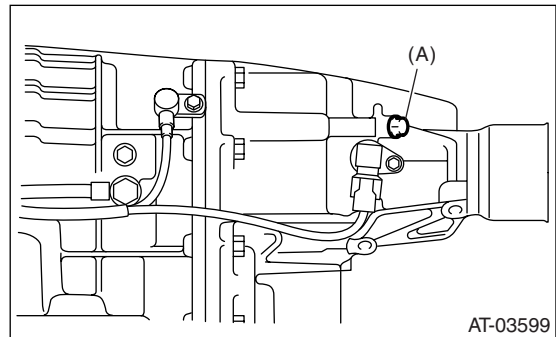

(A) Test plug

STANDARD TRANSFER CLUTCH PRESSURE:

Range position	ON Duty ratio (%)	Acceleration opening angle (%)	Transfer clutch pressure (kPa (kgf/cm ² , psi))	
			AWD mode	FWD mode
2	95	Fully opens (100)	1,000 — 1,200 (10.2 — 12.2, 145 — 174)	—
	60	Adjust ON Duty ratio to 60%.	500 — 700 (5.1 — 7.1, 73 — 102)	—
	5	Fully closed (0)	—	0 (0, 0)
N or P	5	Fully closed (0)	0	—

Automatic Transmission Assembly

AUTOMATIC TRANSMISSION

9. Automatic Transmission Assembly

A: REMOVAL

- 1) Set the vehicle on a lift.
- 2) Open the front hood fully, and support it with a stay.
- 3) Disconnect the battery ground cable.
- 4) Remove the air intake chamber and intake duct. (Non-turbo model) <Ref. to IN(H4SO)-6, REMOVAL, Air Intake Chamber.>
- 5) Remove the intercooler. (Turbo model) <Ref. to IN(H4DOTC)-11, REMOVAL, Intercooler.>
- 6) Remove the air intake chamber stay. (Non-turbo model)

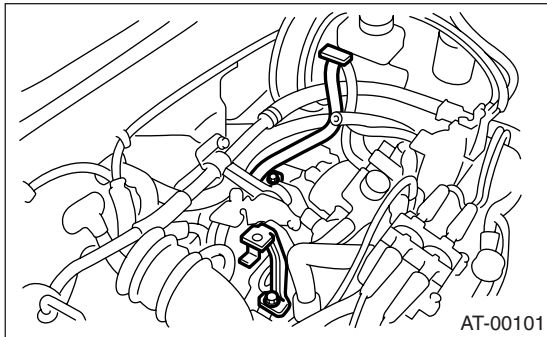

- 7) Disconnect the following connectors.
 - (1) Transmission harness connector

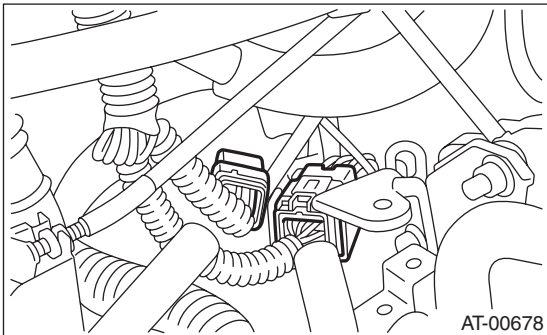

- (2) Transmission ground terminal
- 8) Remove the starter. <Ref. to SC(H4SO)-8, REMOVAL, Starter.>
- 9) Remove the throttle body. <Ref. to FU(H4SO)-12, REMOVAL, Throttle Body.> <Ref. to FU(H4DOTC)-13, REMOVAL, Throttle Body.>

- 10) Remove the pitching stopper.

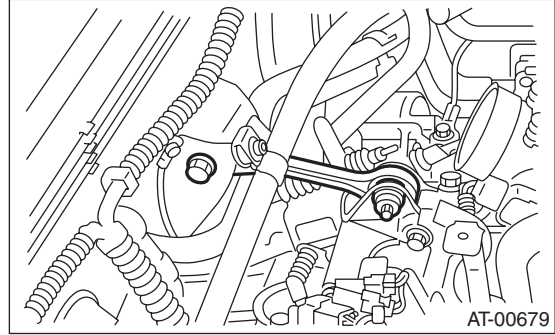

- 11) Separate the torque converter clutch from drive plate.
 - (1) Install the V-belt cover.
 - (2) Remove the service hole plug.
 - (3) Remove the bolts which hold the torque converter clutch to drive plate.
 - (4) While rotating the crank pulley in the direction of engine rotation little by little, remove all the bolts.

CAUTION:
Be careful not to drop bolts into torque converter clutch housing.

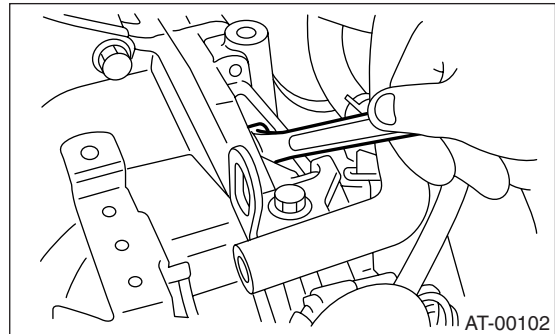

- 12) Install the ST to converter case.
ST 498277200 STOPPER SET

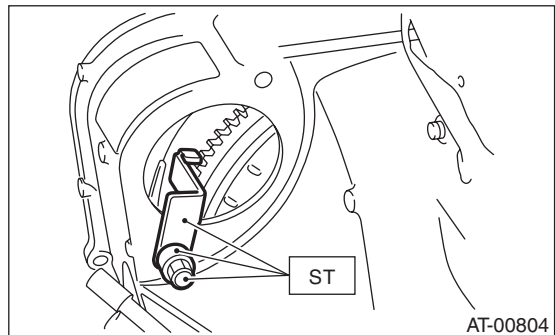

- 13) Remove the ATF level gauge.

NOTE:

Plug the opening to prevent the entry of foreign particles into transmission fluid.

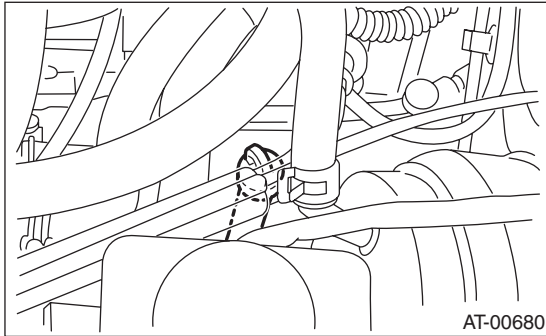

14) Remove the pitching stopper bracket.

15) Set the ST.

ST 41099AC000 ENGINE SUPPORT ASSY

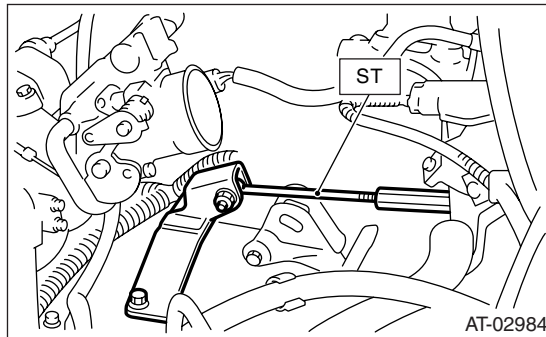

16) Remove the bolt which holds the upper side of transmission to engine.

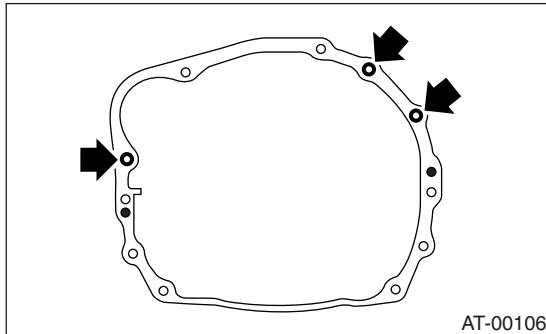

17) Lift-up the vehicle.

18) Remove the under cover.

19) Remove the front, center, rear exhaust pipe and muffler. (Non-turbo model)

<Ref. to EX(H4SO)-4, REMOVAL, Front Exhaust Pipe.> <Ref. to EX(H4SO)-7, REMOVAL, Rear Exhaust Pipe.> <Ref. to EX(H4SO)-8, REMOVAL, Muffler.>

20) Remove the center and rear exhaust pipes, and muffler. (Turbo model)

<Ref. to EX(H4DOTC)-10, REMOVAL, Center Exhaust Pipe.> <Ref. to EX(H4DOTC)-15, REMOVAL, Rear Exhaust Pipe.> <Ref. to EX(H4DOTC)-16, REMOVAL, Muffler.>

21) Drain ATF to remove the ATF drain plug.

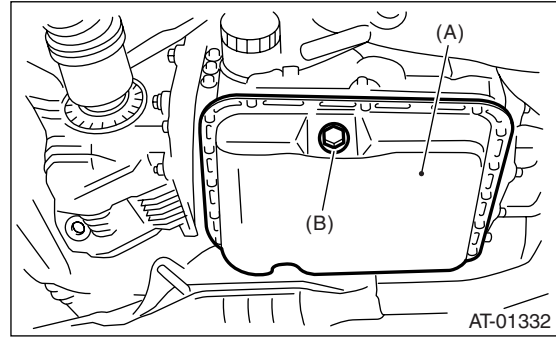

(A) Oil pan

(B) Drain plug (ATF)

22) Disconnect the ATF cooler hoses from pipes of transmission side, and remove the oil charge pipe.

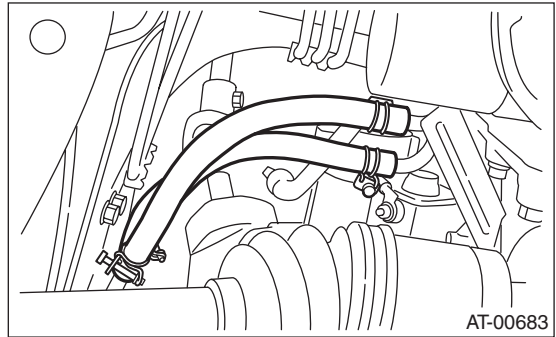

23) Remove the propeller shaft.

<Ref. to DS-16, REMOVAL, Propeller Shaft.>

24) Remove the shift select cable.

<Ref. to CS-27, REMOVAL, Select Cable.>

25) Disconnect the stabilizer link from transverse link.

26) Remove the bolt securing ball joint of transverse link to housing.

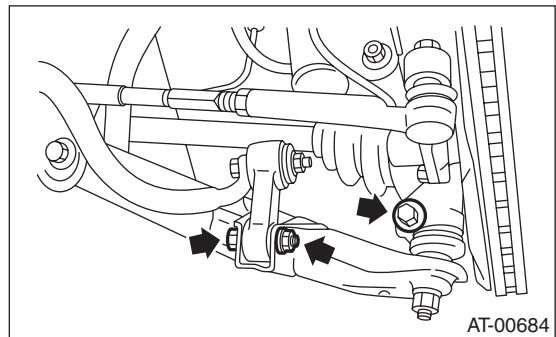

27) Pull out the front drive shaft from transmission.

(1) Using a tire lever or a pinch bar, etc., pull out the front drive shaft until its joint facing to transmission can move smoothly.

NOTE:

Place cloth between tire lever or pinch bar and transmission in order to avoid damaging the side retainer of transmission.

Automatic Transmission Assembly

AUTOMATIC TRANSMISSION

(2) Hold the transmission side joint portion of front drive shaft by hand and extract the housing from the transmission by pressing it outside so as not to stretch the boot.

28) Remove the bolts which hold the clutch housing cover.

29) Remove the nuts which hold the lower side of transmission to engine.

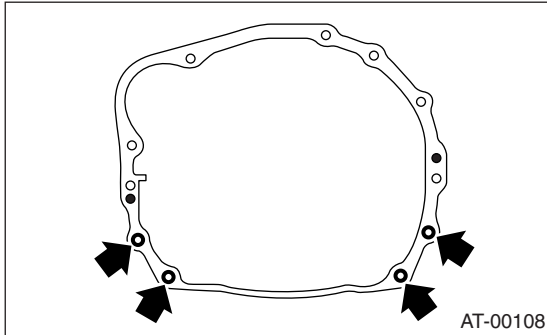

30) Place the transmission jack under transmission.

NOTE:

Make sure that the support plates of transmission jack don't touch the oil pan.

31) Remove the transmission rear crossmember from vehicle.

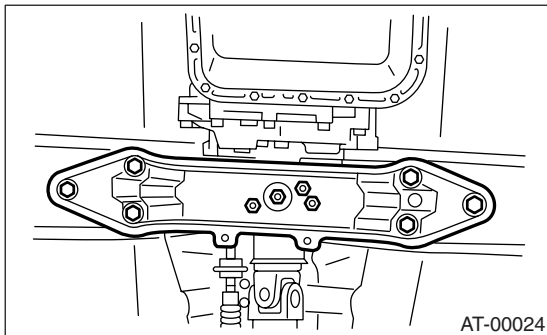

32) While gradually lowering the transmission jack, fully contact the engine support, and then tilt the engine rearward.

33) Remove the transmission.

CAUTION:

Move the transmission and torque converter as a unit away from engine.

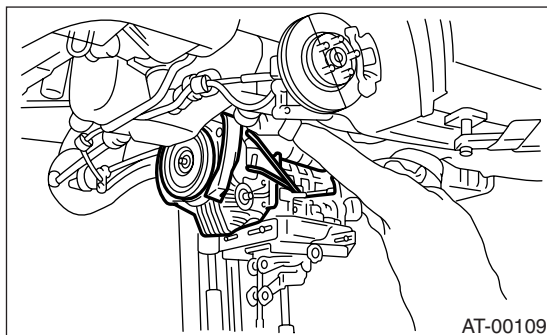

34) Separate the transmission assembly and rear cushion rubber.

B: INSTALLATION

1) Replace the differential side oil seal with new one. <Ref. to 4AT-47, REPLACEMENT, Differential Side Retainer Oil Seal.>

NOTE:

Replacement is not necessary when new oil seal has been installed.

2) Install the rear cushion rubber to transmission assembly.

Tightening torque:

39 N·m (4.0 kgf-m, 29 ft-lb)

3) Install the ST to converter case.

ST 498277200 STOPPER SET

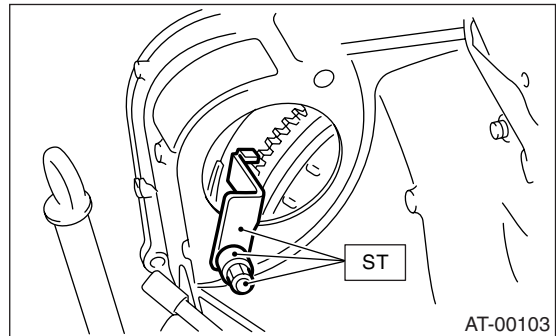

4) Install the transmission onto engine.

(1) Gradually raise the transmission with transmission jack.

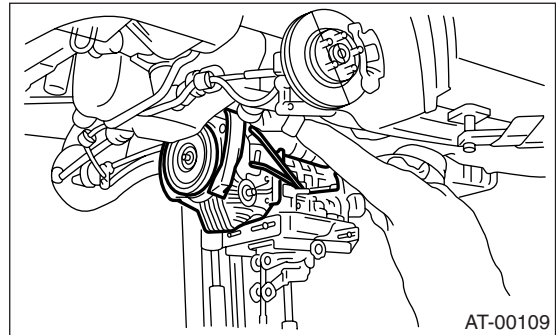

(2) Engage them at splines.

(3) While gradually lifting the transmission jack, turn the screw of engine support, and then tilt the engine forward.

5) Install the transmission rear crossmember.

Tightening torque:

T1: 35 N·m (3.6 kgf-m, 26 ft-lb)

T2: 70 N·m (7.1 kgf-m, 51.6 ft-lb)

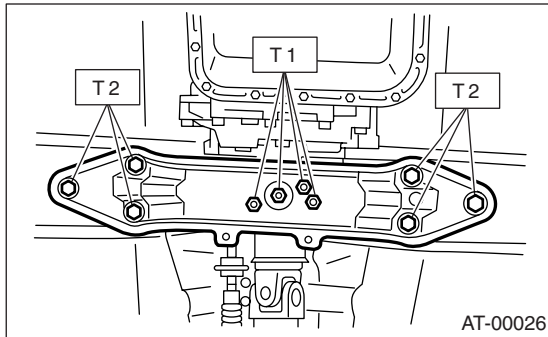

- 6) Take off the transmission jack.
- 7) Tighten the nuts and bolts which hold the lower side of transmission to engine.

Tightening torque:

50 N·m (5.1 kgf-m, 36.9 ft-lb)

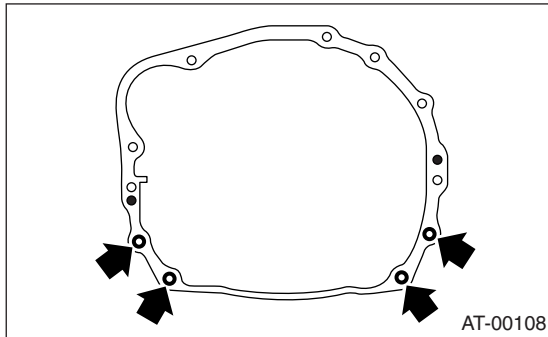

- 8) Tighten the bolt of clutch housing cover.
- 9) Lower the vehicle.
- 10) Connect the engine and transmission.
 - (1) Remove the ST from converter case.

NOTE:

Be careful not to drop the ST into the converter case when removing ST.

ST 498277200 STOPPER SET

- (2) Install the starter.

<Ref. to SC(H4SO)-8, INSTALLATION, Starter.>
- (3) Tighten the bolt which holds the upper side of transmission to engine.

Tightening torque:

50 N·m (5.1 kgf-m, 36.9 ft-lb)

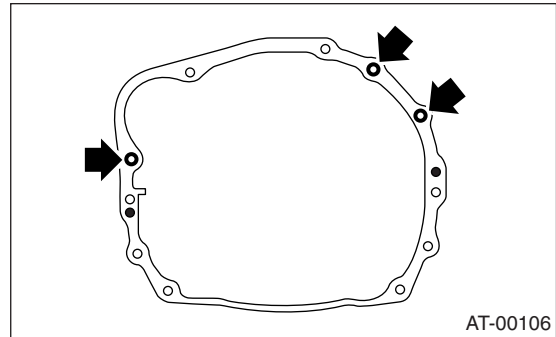

- 11) Install the torque converter clutch to drive plate.
 - (1) Tighten the bolts which hold the torque converter clutch to drive plate.
 - (2) While rotating the crank pulley in the direction of engine rotation little by little, tighten all the bolts.

Tightening torque:

25 N·m (2.5 kgf-m, 18.4 ft-lb)

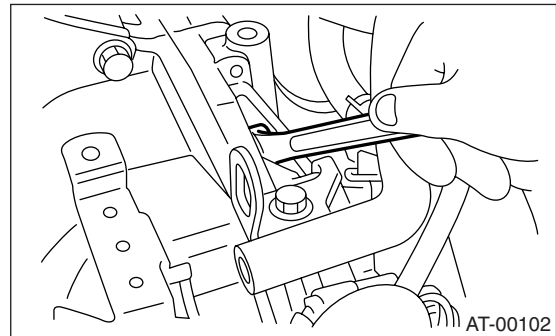

- (3) Clog the plug onto service hole.
- (4) Install the V-belt cover.
- 12) Remove the STs.

ST 41099AC000 ENGINE SUPPORT ASSY

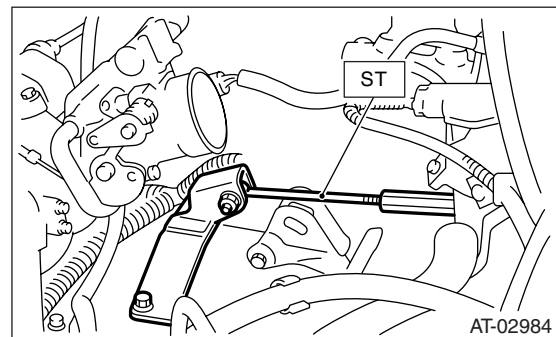

- 13) Install the pitching stopper bracket.

Tightening torque:

41 N·m (4.2 kgf-m, 30.2 ft-lb)

- 14) Install the pitching stopper.

Automatic Transmission Assembly

AUTOMATIC TRANSMISSION

Tightening torque:

T1: 50 N·m (5.1 kgf-m, 36.9 ft-lb)

T2: 58 N·m (5.9 kgf-m, 43 ft-lb)

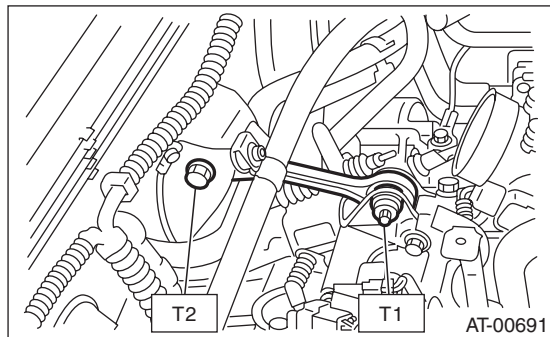

15) Install the throttle body. <Ref. to FU(H4SO)-12, INSTALLATION, Throttle Body.> <Ref. to FU(H4DOTC)-13, INSTALLATION, Throttle Body.>

16) Lift-up the vehicle.

17) Replace the snap ring of front drive shaft with a new one.

18) Apply grease to the oil seal lips.

19) Install the ST to side retainer.

ST 28399SA010 OIL SEAL PROTECTOR

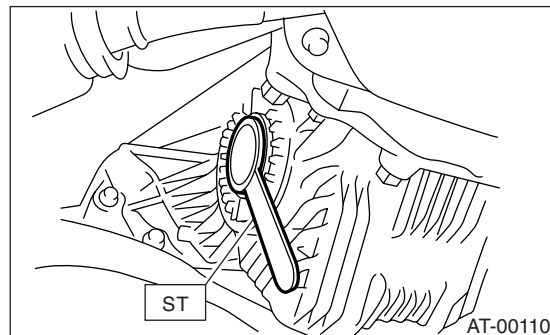

20) Align the spline of front differential shaft to that of differential bevel gear for insertion, and remove them using ST.

ST 28399SA010 OIL SEAL PROTECTOR

21) Insert the front drive shaft into transmission securely by pressing the front housing from outside.

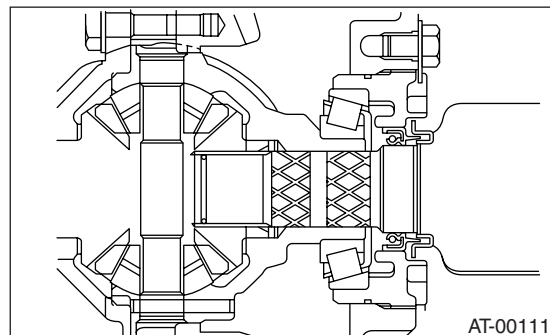

22) Install the ball joint into housing.

23) Connect the stabilizer link to transverse link, and tighten the bolts.

NOTE:

Use a new self-locking nut.

Tightening torque:

T1: 30 N·m (3.1 kgf-m, 22.1 ft-lb)

T2: 50 N·m (5.1 kgf-m, 36.9 ft-lb)

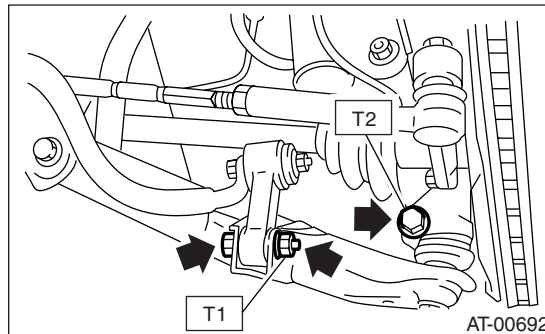

24) Install the shift select cable onto select lever. <Ref. to CS-27, INSTALLATION, Select Cable.>

25) Install the oil charge pipe, and connect the ATF cooler hoses to pipe.

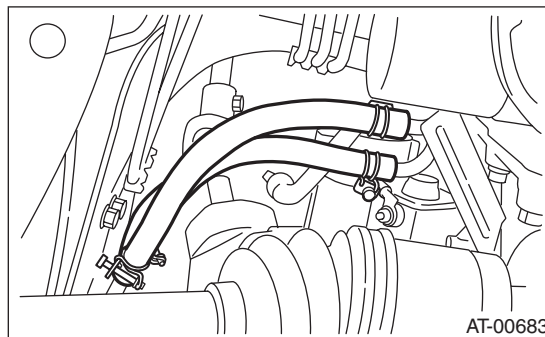

26) Install the propeller shaft.

<Ref. to DS-17, INSTALLATION, Propeller Shaft.>
27) Install the rear exhaust pipe and muffler assembly.

Non-turbo model

<Ref. to EX(H4SO)-7, INSTALLATION, Rear Exhaust Pipe.> <Ref. to EX(H4SO)-8, INSTALLATION, Muffler.>

Turbo model

<Ref. to EX(H4DOTC)-15, INSTALLATION, Rear Exhaust Pipe.> <Ref. to EX(H4DOTC)-16, INSTALLATION, Muffler.>

28) Install the front and center exhaust pipe. (Non-turbo model)

<Ref. to EX(H4SO)-4, INSTALLATION, Front Exhaust Pipe.>

29) Install the center exhaust pipe. (Turbo model)

<Ref. to EX(H4DOTC)-11, INSTALLATION, Center Exhaust Pipe.>

30) Install the under cover.

31) Lower the vehicle.

32) Install the ATF level gauge.

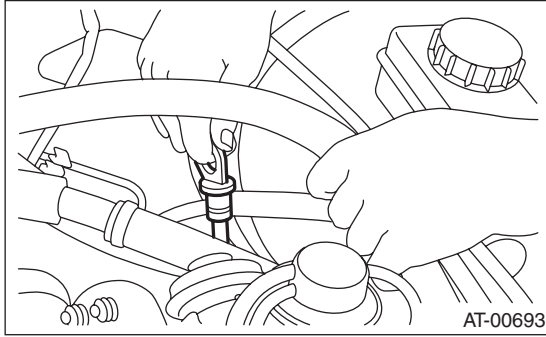

33) Connect the following connectors.

- (1) Transmission harness connectors
- (2) Transmission ground terminal

34) Install the air intake chamber stay.

Tightening torque:

16 N·m (1.6 kgf·m, 11.8 ft·lb)

35) Install the air intake chamber and intake duct. (Non-turbo model) <Ref. to IN(H4SO)-6, INSTALLATION, Air Intake Chamber.>

36) Install the intercooler. (Turbo model) <Ref. to IN(H4DOTC)-11, INSTALLATION, Intercooler.>

37) Connect the battery ground cable.

38) Fill ATF up to the middle of the "COLD" side on level gauge by using oil charge pipe. <Ref. to 4AT-30, Automatic Transmission Fluid.>

39) Take off the vehicle from lift arms.

40) Check select lever operation. <Ref. to 4AT-48, INSPECTION, Inhibitor Switch.>

41) Bleed air from control valve. <Ref. to 4AT-60, PROCEDURE, Air Bleeding of Control Valve.>

42) Check the ATF level. <Ref. to 4AT-30, Automatic Transmission Fluid.>

43) Perform the advance operation of learning control.

<Ref. to 4AT(D)(diag)-15, FACILITATION OF LEARNING CONTROL, OPERATION, Subaru Select Monitor.>

44) Check the road test. <Ref. to 4AT-33, Road Test.>

Transmission Mounting System

AUTOMATIC TRANSMISSION

10. Transmission Mounting System

A: REMOVAL

1. PITCHING STOPPER

- 1) Disconnect the ground cable from battery.
- 2) Remove the air intake chamber. (Non-turbo model) <Ref. to IN(H4SO)-6, REMOVAL, Air Intake Chamber.>
- 3) Remove intercooler. (Turbo model) <Ref. to IN(H4DOTC)-11, REMOVAL, Intercooler.>
- 4) Remove the throttle body. <Ref. to FU(H4SO)-12, REMOVAL, Throttle Body.> <Ref. to FU(H4DOTC)-13, REMOVAL, Throttle Body.>
- 5) Remove the pitching stopper.

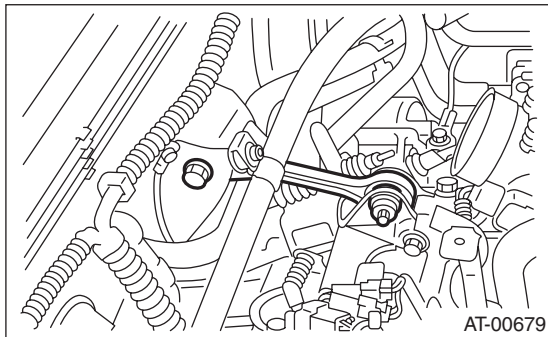

2. TRANSMISSION REAR CROSSMEMBER AND REAR CUSHION RUBBER

- 1) Disconnect the ground cable from battery.
- 2) Jack-up the vehicle and support it with sturdy racks.
- 3) Remove the front, center, rear exhaust pipes and muffler. (Non-turbo model) <Ref. to EX(H4SO)-4, REMOVAL, Front Exhaust Pipe.> <Ref. to EX(H4SO)-7, REMOVAL, Rear Exhaust Pipe.> <Ref. to EX(H4SO)-8, REMOVAL, Muffler.>
- 4) Remove center and rear exhaust pipes, and muffler. (Turbo model) <Ref. to EX(H4DOTC)-10, REMOVAL, Center Exhaust Pipe.> <Ref. to EX(H4DOTC)-15, REMOVAL, Rear Exhaust Pipe.> <Ref. to EX(H4DOTC)-16, REMOVAL, Muffler.>
- 5) Set the transmission jack under the transmission. Make sure that the support plates of transmission jack don't touch the oil pan.

- 6) Remove the transmission rear crossmember.

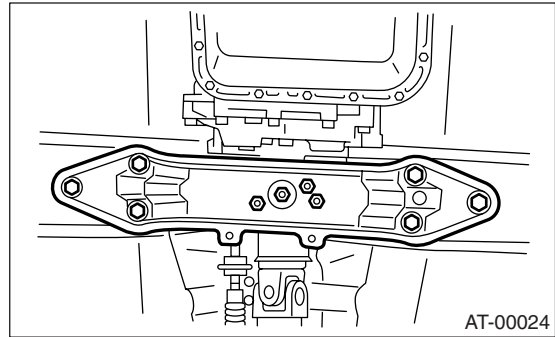

- 7) Remove the rear cushion rubber.

B: INSTALLATION

1. PITCHING STOPPER

- 1) Install the pitching stopper.

Tightening torque:

T1: 50 N·m (5.1 kgf·m, 36.9 ft·lb)

T2: 58 N·m (5.9 kgf·m, 43 ft·lb)

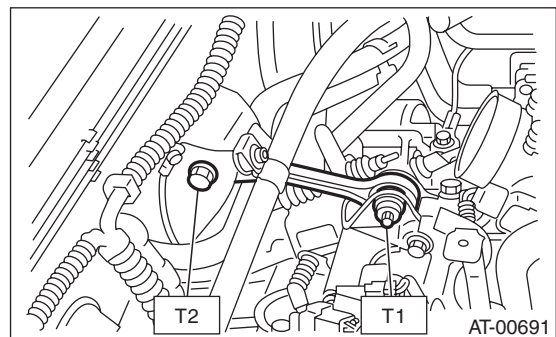

- 2) Install the throttle body. <Ref. to FU(H4SO)-12, INSTALLATION, Throttle Body.> <Ref. to FU(H4DOTC)-13, INSTALLATION, Throttle Body.>
- 3) Install the air intake chamber. (Non-turbo model) <Ref. to IN(H4SO)-6, INSTALLATION, Air Intake Chamber.>
- 4) Remove intercooler. (Turbo model) <Ref. to IN(H4DOTC)-11, INSTALLATION, Intercooler.>

2. TRANSMISSION REAR CROSSMEMBER AND REAR CUSHION RUBBER

- 1) Install the rear cushion rubber.

Tightening torque:

39 N·m (4.0 kgf·m, 29 ft·lb)

- 2) Install the crossmember.

Tightening torque:

T1: 35 N·m (3.6 kgf-m, 26 ft-lb)

T2: 70 N·m (7.1 kgf-m, 51.6 ft-lb)

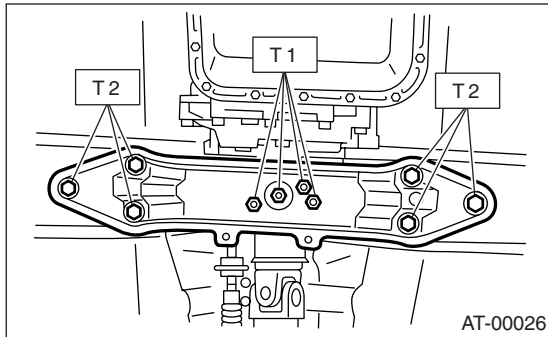

3) Remove the transmission jack.

4) Install the front, center, rear exhaust pipes and the muffler. (Non-turbo model)

<Ref. to EX(H4SO)-4, INSTALLATION, Front Exhaust Pipe.> <Ref. to EX(H4SO)-7, INSTALLATION, Rear Exhaust Pipe.> <Ref. to EX(H4SO)-8, INSTALLATION, Muffler.>

5) Install center and rear exhaust pipes, and muffler. (Turbo model)

<Ref. to EX(H4DOTC)-11, INSTALLATION, Center Exhaust Pipe.> <Ref. to EX(H4DOTC)-15, INSTALLATION, Rear Exhaust Pipe.> <Ref. to EX(H4DOTC)-16, INSTALLATION, Muffler.>

C: INSPECTION

Repair or replace parts if the results of the inspection below are not satisfactory.

1. PITCHING STOPPER

Make sure that the pitching stopper is not bent or damaged. Make sure that the rubber is not stiff, cracked, or otherwise damaged.

2. TRANSMISSION REAR CROSSMEMBER AND REAR CUSHION RUBBER

Make sure that the crossmember is not bent or damaged. Make sure that the cushion rubber is not stiff, cracked, or otherwise damaged.

Extension Case Oil Seal

AUTOMATIC TRANSMISSION

11.Extension Case Oil Seal

A: INSPECTION

Make sure the ATF does not leak from the joint of transmission and propeller shaft. If so, replace the oil seal. <Ref. to 4AT-46, REPLACEMENT, Extension Case Oil Seal.>

B: REPLACEMENT

- 1) Clean the transmission exterior.
- 2) Drain the ATF completely.

NOTE:

- Tighten the ATF drain plug after draining the ATF.
- Use a new gasket.

Tightening torque:

25 N·m (2.5 kgf-m, 18.4 ft-lb)

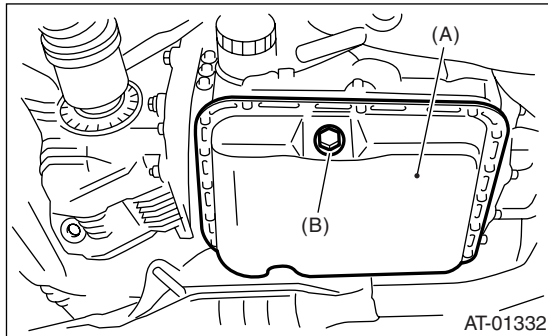

- (A) Oil pan
(B) Drain plug (ATF)

- 3) Remove the rear exhaust pipe and muffler.

Non-turbo model

<Ref. to EX(H4SO)-7, REMOVAL, Rear Exhaust Pipe.> <Ref. to EX(H4SO)-8, REMOVAL, Muffler.>

Turbo model

<Ref. to EX(H4DOTC)-15, REMOVAL, Rear Exhaust Pipe.> <Ref. to EX(H4DOTC)-16, REMOVAL, Muffler.>

- 4) Remove the propeller shaft. <Ref. to DS-16, REMOVAL, Propeller Shaft.>

- 5) Using the ST, remove the oil seal.

ST 398527700 PULLER ASSY

- 6) Using the ST, install the oil seal.

ST 498057300 INSTALLER

- 7) Install the propeller shaft. <Ref. to DS-17, INSTALLATION, Propeller Shaft.>

- 8) Install the rear exhaust pipe and muffler.

Non-turbo model

<Ref. to EX(H4SO)-7, INSTALLATION, Rear Exhaust Pipe.> <Ref. to EX(H4SO)-8, INSTALLATION, Muffler.>

Turbo model

<Ref. to EX(H4DOTC)-15, INSTALLATION, Rear Exhaust Pipe.> <Ref. to EX(H4DOTC)-16, INSTALLATION, Muffler.>

- 9) Pour ATF and check the ATF level. <Ref. to 4AT-30, Automatic Transmission Fluid.>

12. Differential Side Retainer Oil Seal

A: INSPECTION

Check the leakage of gear oil from differential side retainer oil seal part. If there is oil leakage, replace the oil seal.

B: REPLACEMENT

- 1) Lift-up the vehicle.
- 2) Remove the front exhaust pipe and center exhaust pipe.

Non-turbo model

<Ref. to EX(H4SO)-4, REMOVAL, Front Exhaust Pipe.>

Turbo model

<Ref. to EX(H4DOTC)-10, REMOVAL, Center Exhaust Pipe.>

- 3) Drain the differential gear by removing differential gear oil drain plug.

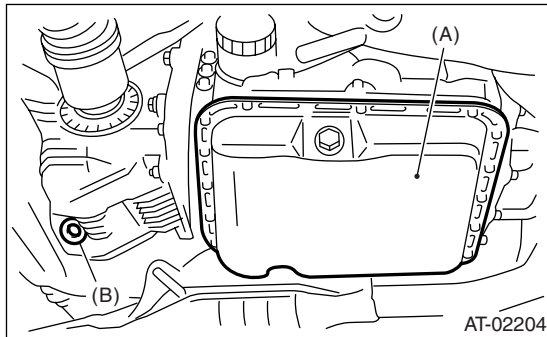

- (A) Oil pan
(B) Differential gear oil drain plug

- 4) Replace new gasket and tighten the differential oil drain plug.

Tightening torque:

44 N·m (4.5 kgf·m, 32.5 ft·lb) (Aluminum gasket)

70 N·m (7.1 kgf·m, 51.6 ft·lb) (Copper gasket)

- 5) Separate the front drive shaft from transmission. <Ref. to DS-33, REMOVAL, Front Drive Shaft.>
- 6) Remove the differential side retainer oil seal using driver which wrapped with vinyl tape or etc.
- 7) Using ST, install the differential side retainer oil seal by slightly tapping with hammer.

ST 18675AA000 DIFFERENTIAL SIDE OIL SEAL INSTALLER

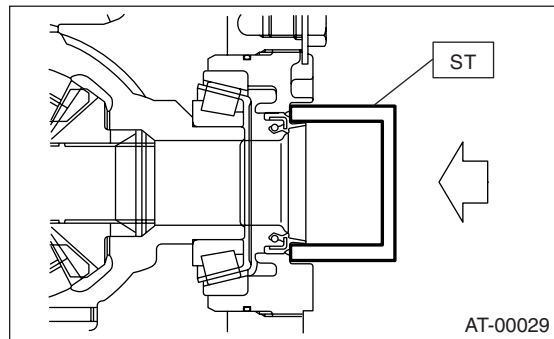

- 8) Apply oil to the oil seal lips.

9) Using the ST, install the front drive shaft. <Ref. to DS-33, INSTALLATION, Front Drive Shaft.>

ST 28399SA010 OIL SEAL PROTECTOR

- 10) Install the front exhaust pipe and center exhaust pipe.

Non-turbo model

<Ref. to EX(H4SO)-4, INSTALLATION, Front Exhaust Pipe.>

Turbo model

<Ref. to EX(H4DOTC)-11, INSTALLATION, Center Exhaust Pipe.>

- 11) Lower the vehicle.

- 12) Pour differential gear oil into the gauge hole.

Recommended gear oil:

<Ref. to RM-2, LUBRICANTS, RECOMMENDED MATERIALS, Recommended Materials.>

Differential gear oil capacity:

1.1 — 1.3 ℓ (1.3 — 1.4 US qt, 1.0 — 1.1 Imp qt)

- 13) Check the gear oil amount. <Ref. to 4AT-32, INSPECTION, Differential Gear Oil.>

13. Inhibitor Switch

A: INSPECTION

When the driving condition or starter motor operation is erroneous, first check the shift linkage for improper operation. If the shift linkage is functioning properly, check the inhibitor switch.

- 1) Disconnect the inhibitor switch connector.
- 2) Check continuity in inhibitor switch circuits with the select lever moved to each position.

NOTE:

- Also check that continuity in ignition circuit does not exist when the select lever is in “R”, “D”, “3”, “2” and “1” ranges.
- If the inhibitor switch is inoperative, check for poor contact of connector on transmission side.

	Position	Pin No.
Signal sent to TCM	P	4 — 3
	R	4 — 2
	N	4 — 1
	D	4 — 8
	3	4 — 7
	2	4 — 6
	1	4 — 5
Ignition circuit	P/N	12 — 11
Back-up light circuit	R	10 — 9

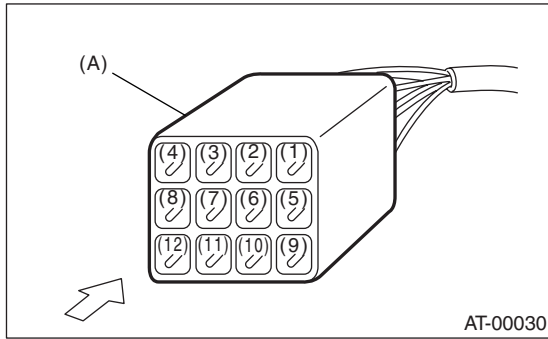

(A) Inhibitor switch connector

- 3) Check if there is continuity at equal points when the select lever is tilted 1.5° in both directions from “N” range.

If there is continuity in one direction and the continuity in the other or if there is continuity at unequal points, adjust the inhibitor switch. <Ref. to 4AT-48, ADJUSTMENT, Inhibitor Switch.>

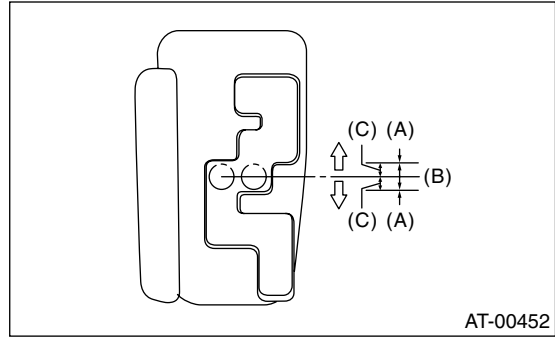

- (A) Continuity does not exist.
- (B) Continuity exists.
- (C) 1.5°

- 4) Repeat the above checks. If there are abnormalities, adjust the select cable. <Ref. to CS-28, ADJUSTMENT, Select Cable.>

B: ADJUSTMENT

- 1) Move the select lever to “N” range.
- 2) Loosen the three inhibitor switch securing bolts.
- 3) Insert the ST as vertical as possible into the holes in inhibitor switch lever and switch body.
ST 499267300 STOPPER PIN

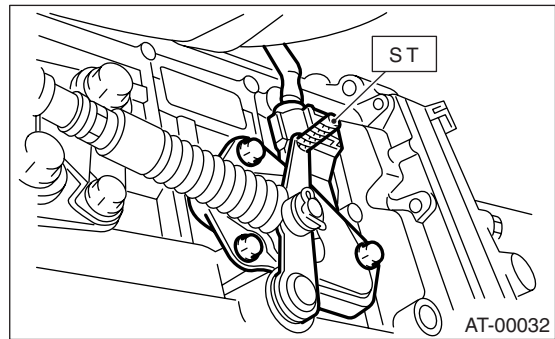

- 4) Tighten the three inhibitor switch bolts.

Tightening torque:
3.5 N·m (0.36 kgf·m, 2.6 ft·lb)

- 5) Repeat the above checks. If the inhibitor switch is determined to be “faulty”, replace it.

C: REMOVAL

- 1) Set up the vehicle on a lift.
- 2) Move the select lever to “N” range.
- 3) Remove the air intake chamber (Non-turbo model). <Ref. to IN(H4SO)-6, REMOVAL, Air Intake Chamber.>
- 4) Remove the intercooler. (Turbo model) <Ref. to IN(H4DOTC)-11, REMOVAL, Intercooler.>

5) Disconnect the inhibitor switch connector.

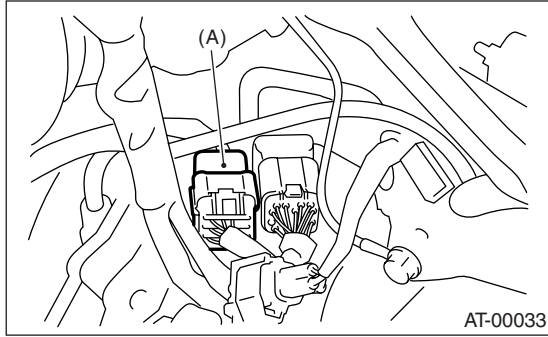

(A) Inhibitor switch

11) Remove the bolts.

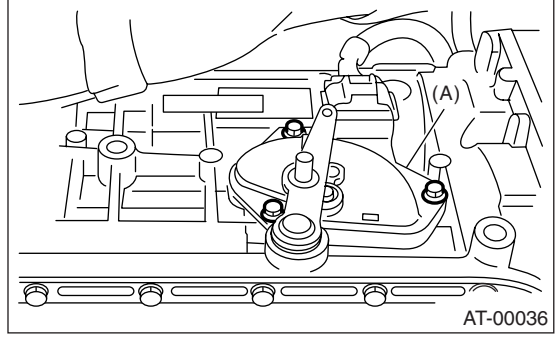

(A) Inhibitor switch

6) Remove the inhibitor switch connector from stay.
7) Lift-up the vehicle.

8) Remove the front and center exhaust pipes.
<Ref. to EX(H4SO)-4, REMOVAL, Front Exhaust Pipe.> <Ref. to EX(H4DOTC)-10, REMOVAL, Center Exhaust Pipe.>

9) Remove the snap pin and washer from range select lever.

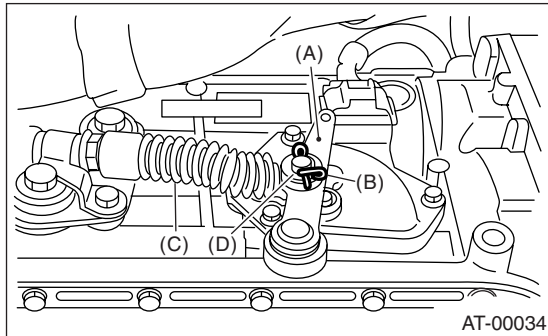

(A) Range select lever
(B) Snap pin
(C) Select cable
(D) Washer

12) Move the range select lever to parking position (left side).

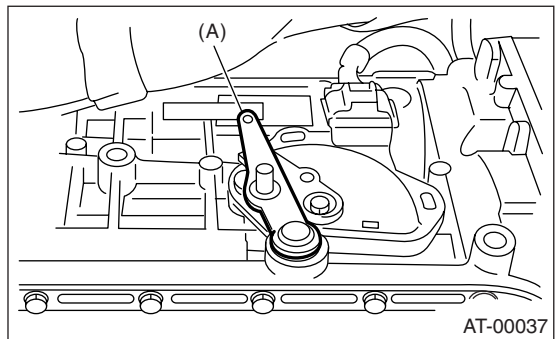

(A) Range select lever

10) Remove the plate assembly from transmission case.

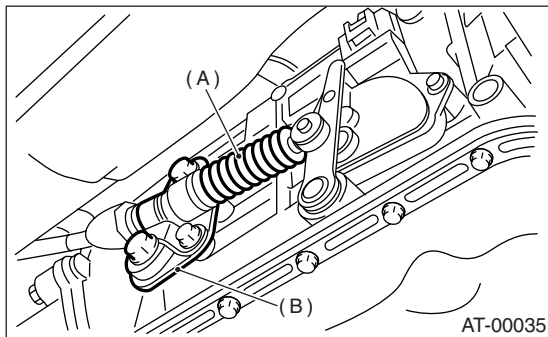

(A) Select cable
(B) Plate ASSY

13) Remove the inhibitor switch from transmission.

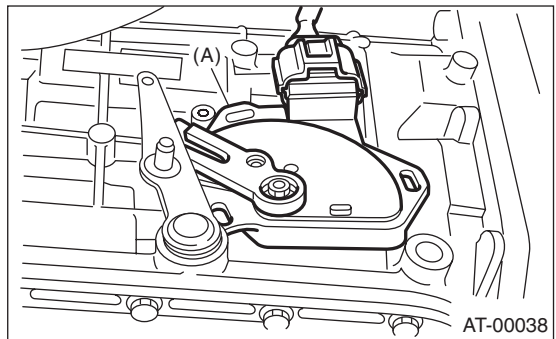

(A) Inhibitor switch

14) Disconnect the inhibitor switch harness connector from inhibitor switch.

D: INSTALLATION

1) Connect the inhibitor switch harness connector to inhibitor switch.

Inhibitor Switch

AUTOMATIC TRANSMISSION

2) Install the inhibitor switch to transmission case.

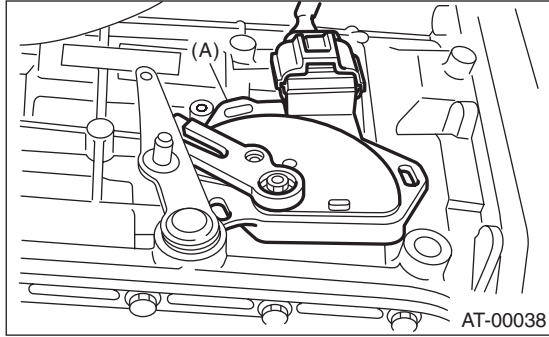

(A) Inhibitor switch

3) Move the range select lever to neutral position.
4) Using the ST, tighten the bolts of inhibitor switch.
ST 499267300 STOPPER PIN

Tightening torque:

3.5 N·m (0.36 kgf-m, 2.6 ft-lb)

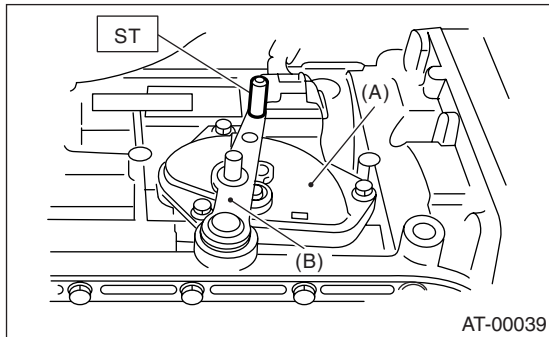

(A) Inhibitor switch
(B) Range select lever

5) Install the select cable to range select lever.
6) Install the plate assembly to transmission.

Tightening torque:

T: 25 N·m (2.5 kgf-m, 18.4 ft-lb)

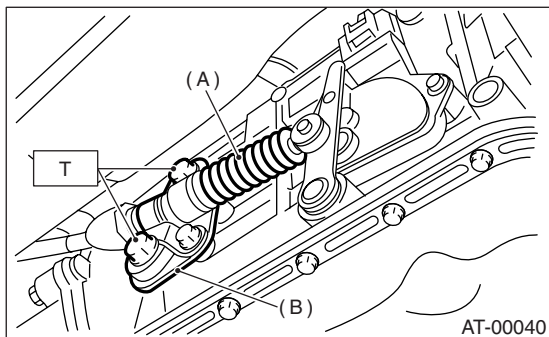

(A) Select cable
(B) Plate ASSY

7) Install the washer and snap pin to range select lever.

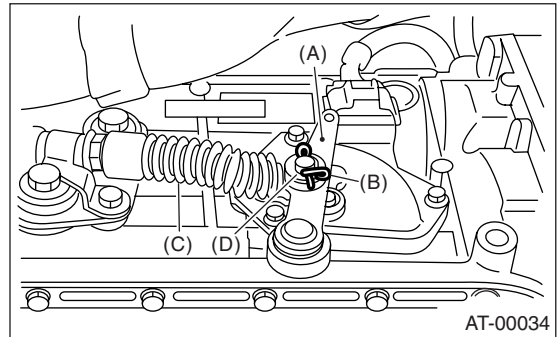

(A) Range select lever
(B) Snap ring
(C) Select cable
(D) Washer

8) Install the front and center exhaust pipes. (Non-turbo model)

<Ref. to EX(H4SO)-4, INSTALLATION, Front Exhaust Pipe.>

9) Install the center exhaust pipe. (Turbo model)

<Ref. to EX(H4DOTC)-11, INSTALLATION, Center Exhaust Pipe.>

10) Lower the vehicle.

11) Install the inhibitor switch connector from stay.

12) Connect the inhibitor switch connector.

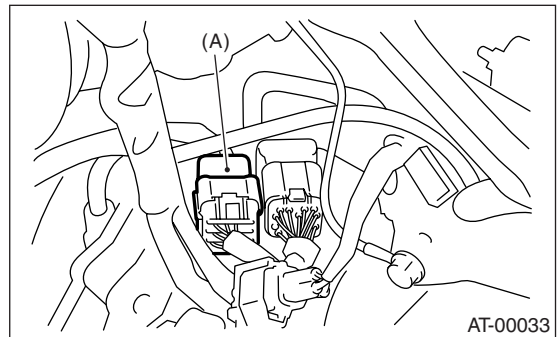

(A) Inhibitor switch

13) Install the air intake chamber. (Non-turbo model) <Ref. to IN(H4SO)-6, INSTALLATION, Air Intake Chamber.>

14) Install the intercooler. (Turbo model) <Ref. to IN(H4DOTC)-11, INSTALLATION, Intercooler.>

15) Inspect the inhibitor switch. <Ref. to 4AT-48, INSPECTION, Inhibitor Switch.>

14. Front Vehicle Speed Sensor

A: REMOVAL

- 1) Set up the vehicle on a lift.
- 2) Disconnect the ground cable from battery.
- 3) Remove the air intake chamber. (Non-turbo model) <Ref. to IN(H4SO)-6, REMOVAL, Air Intake Chamber.>
- 4) Remove the intercooler. (Turbo model) <Ref. to IN(H4DOTC)-11, REMOVAL, Intercooler.>
- 5) Disconnect the transmission connector.

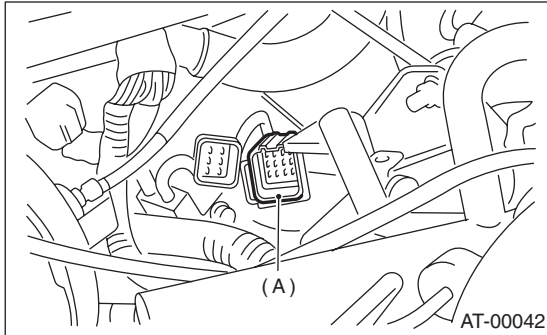

(A) Transmission connector

- 6) Remove the pitching stopper. <Ref. to 4AT-44, REMOVAL, Transmission Mounting System.>
- 7) Remove the transmission connector from stay.
- 8) Lift-up the vehicle.
- 9) Clean the transmission exterior.
- 10) Drain the ATF completely.

NOTE:

- Tighten the ATF drain plug after draining the ATF.
- Use a new gasket.

Tightening torque:

25 N·m (2.5 kgf·m, 18.4 ft·lb)

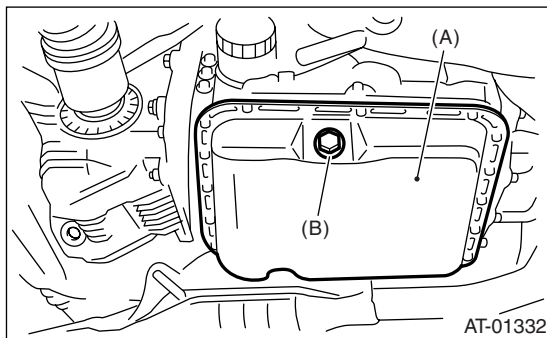

(A) Oil pan
(B) Drain plug (ATF)

- 11) Remove the front, center, exhaust pipes and muffler. (Non-turbo model) <Ref. to EX(H4SO)-4, REMOVAL, Front Exhaust Pipe.> <Ref. to EX(H4SO)-7, REMOVAL, Rear Exhaust Pipe.> <Ref. to EX(H4SO)-8, REMOVAL, Muffler.>
- 12) Remove the center, rear exhaust pipe and muffler. (Turbo model) <Ref. to EX(H4DOTC)-10, REMOVAL, Center Exhaust Pipe.> <Ref. to EX(H4DOTC)-15, REMOVAL, Rear Exhaust Pipe.> <Ref. to EX(H4DOTC)-16, REMOVAL, Muffler.>
- 13) Remove the propeller shaft. <Ref. to DS-16, REMOVAL, Propeller Shaft.>
- 14) Place the transmission jack under transmission.

NOTE:

Make sure that the support plates of transmission jack don't touch the crossmember.

- 15) Remove the transmission rear crossmember bolts.

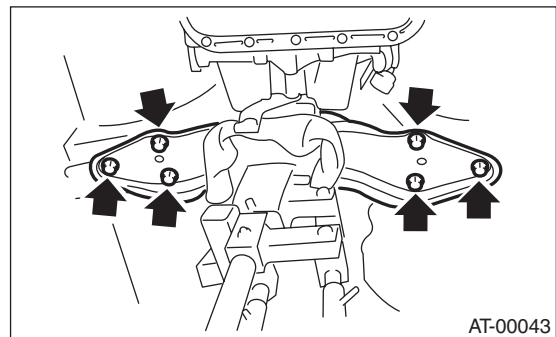

- 16) Lower the AT jack.

NOTE:

Do not separate the AT jack and transmission.

- 17) Remove the oil cooler inlet and outlet pipe.

NOTE:

When removing the outlet pipe, be careful not to lose balls and springs used with retaining screws.

- 18) Remove the front and torque converter turbine speed sensor.

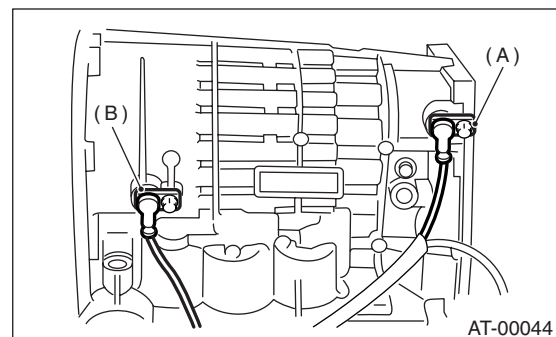

(A) Front vehicle speed sensor
(B) Torque converter turbine speed sensor

Front Vehicle Speed Sensor

AUTOMATIC TRANSMISSION

19) Disconnect the connector of rear vehicle speed sensor. (VTD model)

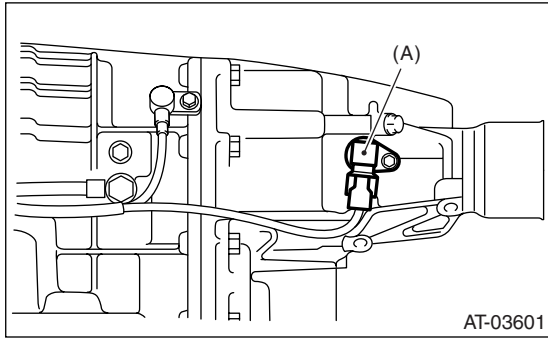

(A) Rear vehicle speed sensor

20) Disconnect the connector from rear vehicle speed sensor. (MP-T model)

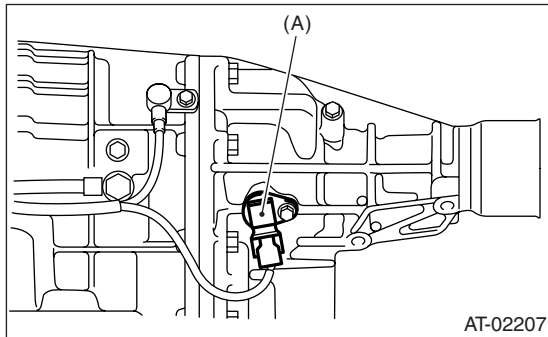

(A) Rear vehicle speed sensor

21) Remove the oil pan.

22) Disconnect the harness connector and transmission ground terminal.

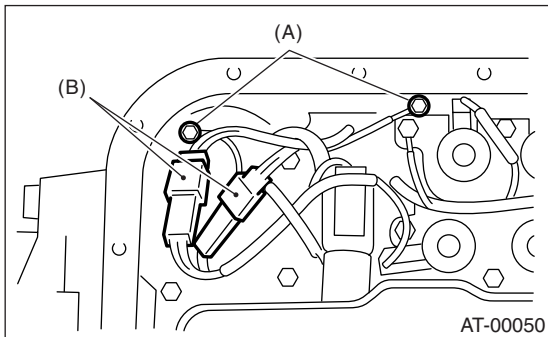

(A) Transmission ground

(B) Harness connector

23) Remove the harness assembly.

B: INSTALLATION

1) Pass the harness assembly through the hole in the transmission case.

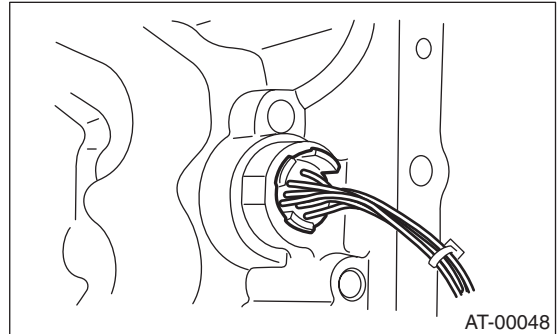

2) Connect the harness connector and transmission ground.

Tightening torque:

8 N·m (0.8 kgf·m, 5.8 ft·lb)

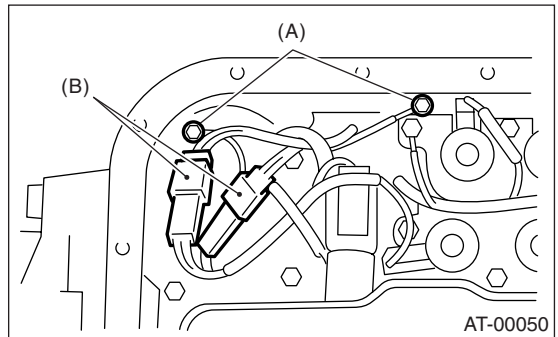

(A) Transmission ground

(B) Harness connector

3) Apply proper amount of liquid gasket to the entire oil pan mating surface.

Liquid gasket:

THREE BOND 1217B (Part No. K0877YA020)

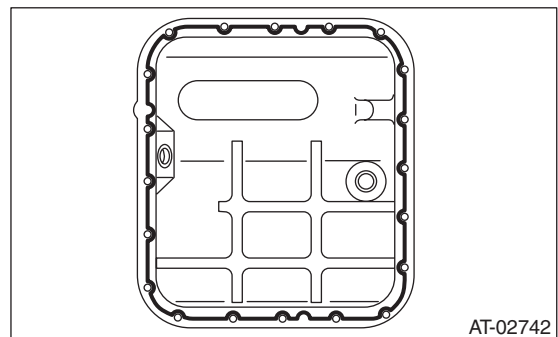

4) Apply liquid gasket fully to three holes other than screw holes on transmission case.

Front Vehicle Speed Sensor

AUTOMATIC TRANSMISSION

Liquid gasket:
THREE BOND 1217B (Part No. K0877YA020)

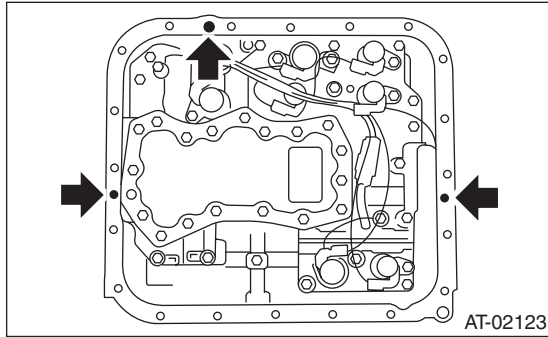

5) Install the oil pan.

Tightening torque:
5 N·m (0.5 kgf-m, 3.6 ft-lb)

6) Connect the connector of rear vehicle speed sensor. (MP-T model)

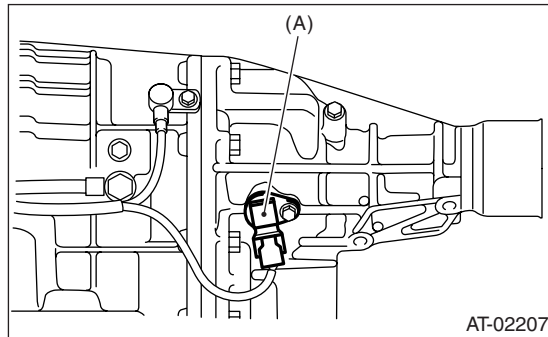

(A) Rear vehicle speed sensor

7) Connect the connector of rear vehicle speed sensor. (VTD model)

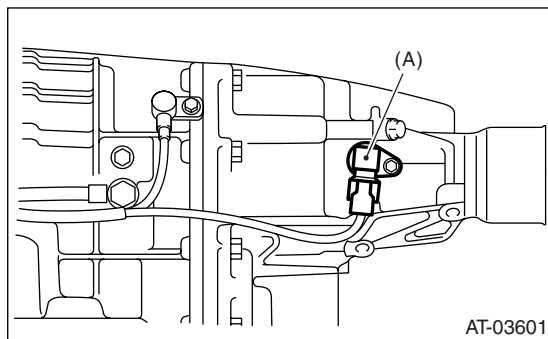

(A) Rear vehicle speed sensor

8) Install the front vehicle speed sensor and torque converter turbine speed sensor, and then fasten the harness.

Tightening torque:
7 N·m (0.7 kgf-m, 5.1 ft-lb)

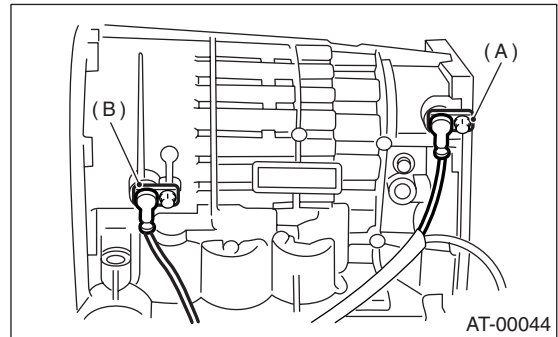

(A) Front vehicle speed sensor
(B) Torque converter turbine speed sensor

9) Install the inlet pipe.

NOTE:

Be sure to use a new copper washer.

Tightening torque:
T1: 25 N·m (2.5 kgf-m, 18.4 ft-lb)
T2: 45 N·m (4.6 kgf-m, 33 ft-lb)
T3: 40 N·m (4.1 kgf-m, 29.5 ft-lb)

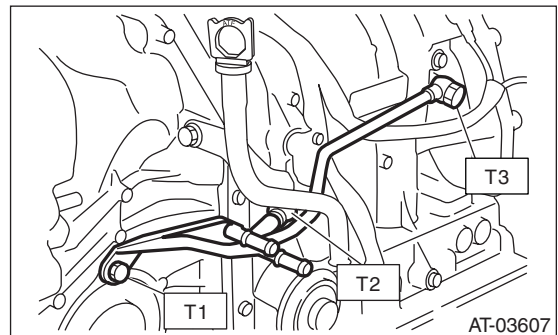

10) Install the transmission rear crossmember bolts.

Tightening torque:
70 N·m (7.1 kgf-m, 51 ft-lb)

11) Install the propeller shaft. <Ref. to DS-17, INSTALLATION, Propeller Shaft.>

12) Install the front, center, rear exhaust pipes and muffler. (Non-turbo model)

<Ref. to EX(H4SO)-4, INSTALLATION, Front Exhaust Pipe.> <Ref. to EX(H4SO)-7, INSTALLATION, Rear Exhaust Pipe.> <Ref. to EX(H4SO)-8, INSTALLATION, Muffler.>

13) Install the center, rear exhaust pipes and muffler. (Turbo model)

<Ref. to EX(H4DOTC)-11, INSTALLATION, Center Exhaust Pipe.> <Ref. to EX(H4DOTC)-15, INSTALLATION, Rear Exhaust Pipe.> <Ref. to EX(H4DOTC)-16, INSTALLATION, Muffler.>

14) Lower the vehicle.

15) Install the transmission connector to the stay.

Front Vehicle Speed Sensor

AUTOMATIC TRANSMISSION

16) Install the pitching stopper. <Ref. to 4AT-44, INSTALLATION, Transmission Mounting System.>

17) Install the air intake chamber. (Non-turbo model) <Ref. to IN(H4SO)-6, INSTALLATION, Air Intake Chamber.>

18) Install the intercooler. (Turbo model)
<Ref. to IN(H4DOTC)-11, INSTALLATION, Intercooler.>

15.Rear Vehicle Speed Sensor

A: REMOVAL

- 1) Set the vehicle on a lift, and then lift-up the vehicle.
- 2) Disconnect the connector from rear vehicle speed sensor.

- MP-T model

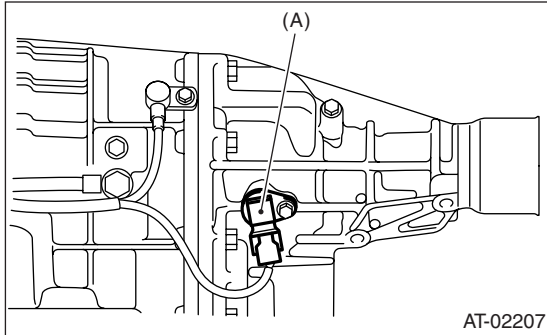

(A) Rear vehicle speed sensor

- VTD model

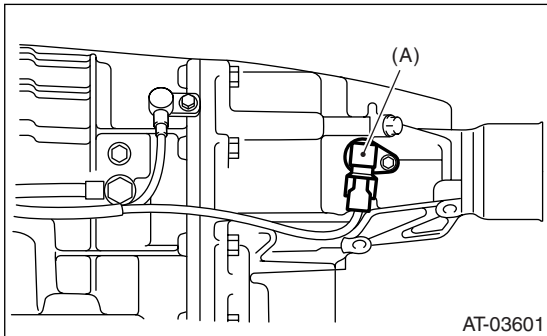

(A) Rear vehicle speed sensor

- 3) Remove the rear vehicle speed sensor.

- MP-T model

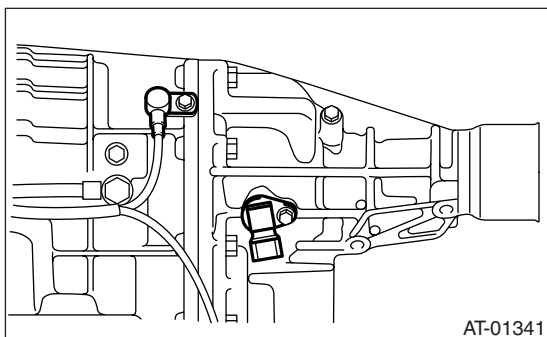

- VTD model

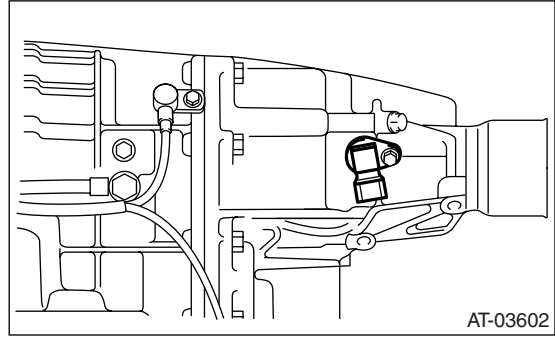

B: INSTALLATION

Install in the reverse order of removal.

NOTE:

Replace with a new O-ring.

Tightening torque:

7 N·m (0.7 kgf-m, 5.1 ft-lb)

16. Torque Converter Turbine Speed Sensor

A: REMOVAL

When removing the torque converter turbine speed sensor, refer to "Front Vehicle Speed Sensor".
<Ref. to 4AT-51, REMOVAL, Front Vehicle Speed Sensor.>

B: INSTALLATION

When installing the torque converter turbine speed sensor, refer to "Front Vehicle Speed Sensor"
<Ref. to 4AT-52, INSTALLATION, Front Vehicle Speed Sensor.>

17. Control Valve Body

A: REMOVAL

- 1) Set the vehicle on a lift.
- 2) Disconnect the ground cable from battery.
- 3) Lift-up the vehicle.
- 4) Clean the transmission exterior.
- 5) Remove the drain plug and gasket, and then drain ATF.

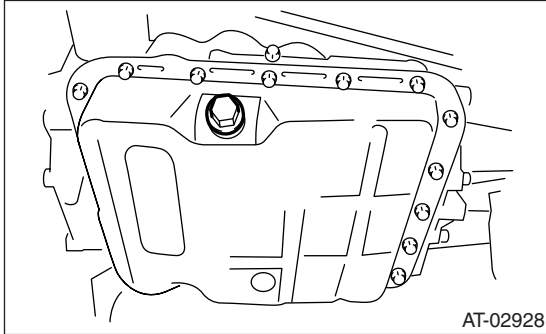

- 6) Replace the gasket with a new one, and then tighten the drain plug.

Tightening torque:

25 N·m (2.5 kgf-m, 18.4 ft-lb)

- 7) Remove the oil pan.

CAUTION:

Be careful not to allow dirt or dust to get into the oil pan.

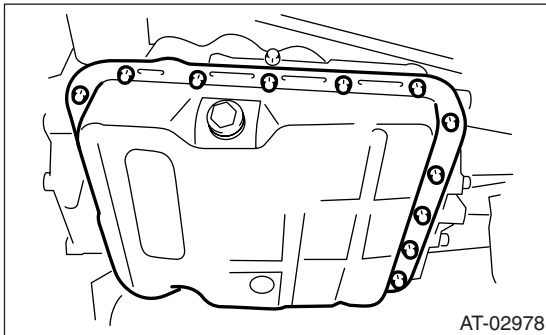

- 8) Remove the magnet.

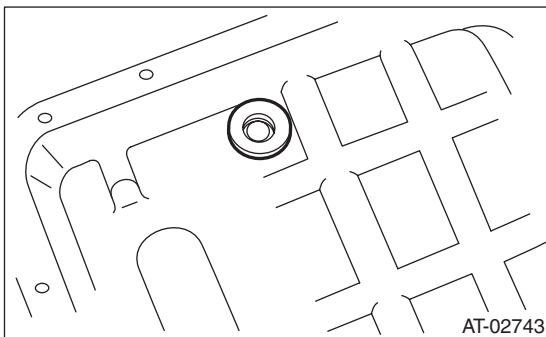

- 9) Clean the magnet.
- 10) Remove the liquid gasket completely from oil pan and transmission case.

- 11) Remove the control valve connector.

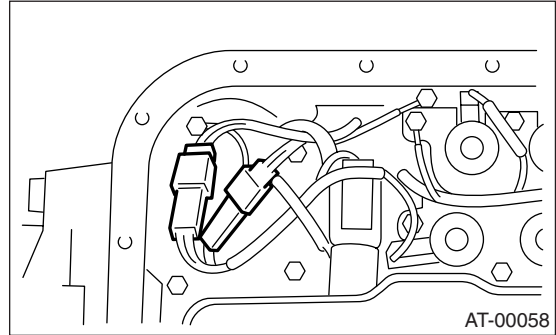

- 12) Remove the oil cooler pipe.

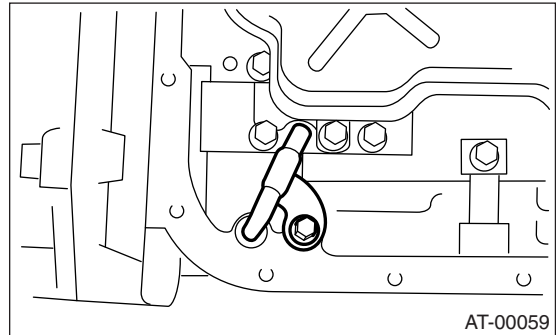

- 13) Remove the control valve body.

NOTE:

Replace the control valve body as assembly, because the control valve body can not be disassembled.

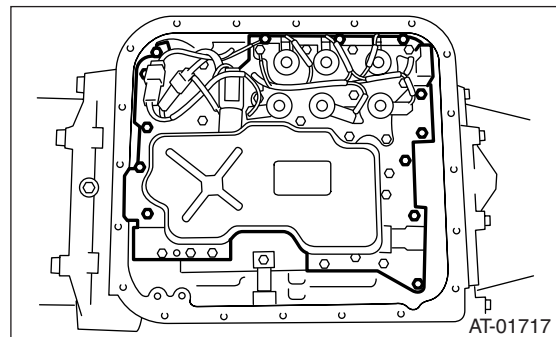

B: INSTALLATION

- 1) Check the control valve body for dirt and dust.
- 2) Temporarily install the control valve body to transmission.
- 3) Install the oil cooler pipe.

Control Valve Body

AUTOMATIC TRANSMISSION

Tightening torque:

8 N·m (0.8 kgf·m, 5.8 ft-lb)

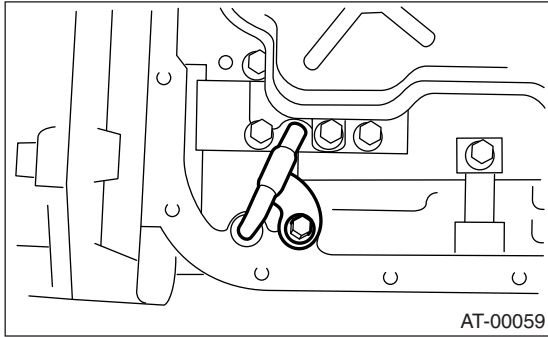

4) Tighten the bolts evenly.

Tightening torque:

8 N·m (0.8 kgf·m, 5.8 ft-lb)

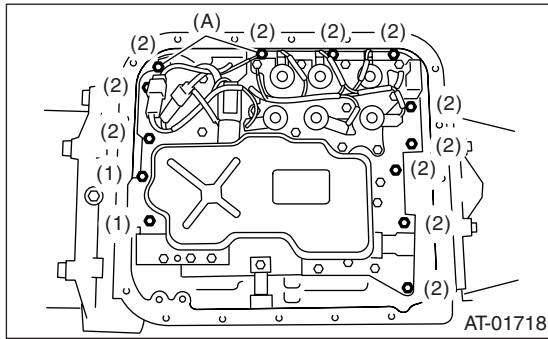

(A) Transmission ground

Bolt length mm (in)

(1) 35 (1.38)

(2) 30 (1.18)

5) Connect the control valve connector.

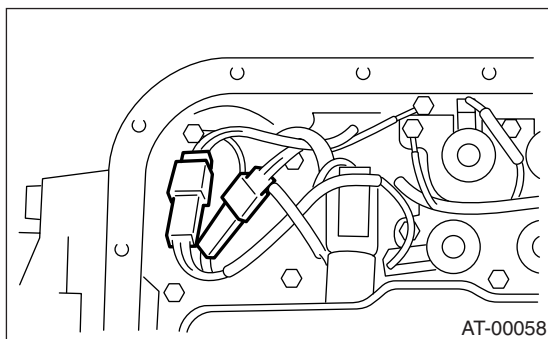

6) Attach the magnet at specified position of oil pan.

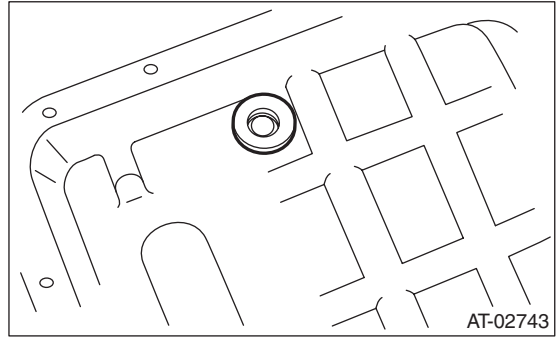

7) Apply proper amount of liquid gasket to the entire oil pan mating surface.

Liquid gasket:

THREE BOND 1217B (Part No. K0877YA020)

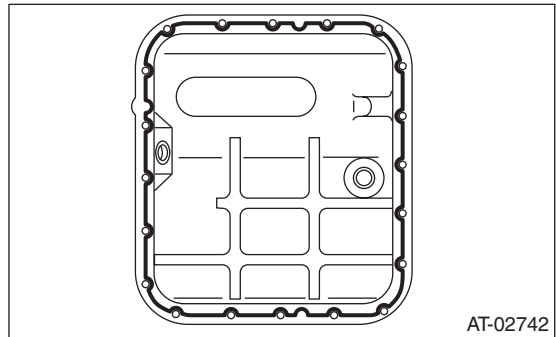

8) Apply liquid gasket fully to three holes other than screw holes on transmission case.

Liquid gasket:

THREE BOND 1217B (Part No. K0877YA020)

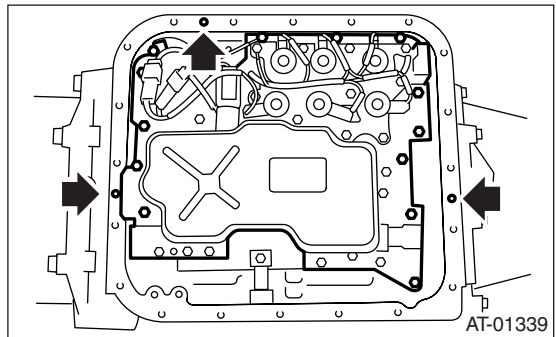

9) Install the oil pan with tightening bolts evenly.

Tightening torque:

5 N·m (0.5 kgf·m, 3.6 ft-lb)

10) Pour ATF into the oil charge pipe.

Recommended fluid:

<Ref. to 4AT-3, HYDRAULIC CONTROL AND LUBRICATION, SPECIFICATION, General Description.>

Fluid capacity:

Fill the same amount of fluid drained from drain plug hole.

11) Bleed the air from control valve. <Ref. to 4AT-60, Air Bleeding of Control Valve.>

12) Check the level of ATF. <Ref. to 4AT-30, Automatic Transmission Fluid.>

13) Perform the advance operation of learning control.

<Ref. to 4AT(D)(diag)-15, FACILITATION OF LEARNING CONTROL, OPERATION, Subaru Select Monitor.>

C: INSPECTION

Make sure that each component is free of harmful gouges, cuts, or dust.

18. Air Bleeding of Control Valve

A: PROCEDURE

- 1) Set the select lever to "P" range and apply parking brake, then lift-up the vehicle.
- 2) Connect the SUBARU Select Monitor to vehicle.
- 3) Using SUBARU Select Monitor, check that the DTC is not output.
- 4) Using SUBARU Select Monitor, check that ATF temperature is less than 60°C (140°F). <Ref. to 4AT(D)(diag)-2, PROCEDURE, Basic Diagnostic Procedure.>
- 5) Set the SUBARU Select Monitor to OFF.
- 6) Turn the ignition switch to OFF.
- 7) With pressing shift lock release button, set the select lever to "R" range.
- 8) Depress the brake pedal fully with left foot until air bleeding is complete.
- 9) Turn the ignition switch to ON.
- 10) Set the select lever to "P" range, and then wait for more than three seconds.
- 11) Set the select lever to "R" range, and then wait for more than three seconds.
- 12) Set the select lever to "N" range, and then wait for more than three seconds.
- 13) Set the select lever to "D" range, and then wait for more than three seconds.
- 14) Set the select lever to "N" range, and then wait for more than three seconds.
- 15) Slightly depress the accelerator pedal to full open.
- 16) Slightly release the accelerator pedal to close.
- 17) Start the engine.
- 18) Set the select lever to "D" range.
- 19) Turn the SUBARU Select Monitor power to ON.
- 20) On the SUBARU Select Monitor, select the "individual system inspection" of main menu.
- 21) On the "individual system inspection" selection menu, select the "individual system inspection" and air bleeding of control valve will start in transmission. At this time, AT OIL TEMP light in the combination meter blinks at 2 Hz. If the AT OIL TEMP light does not blink, repeat the procedures from step 4).
- 22) Air bleeding of control valve is finished, when AT OIL TEMP light blink in the combination meter changes from 2 Hz to 0.5 Hz, on control valve will finish.

NOTE:

Repeat the procedure from step 4) if AT OIL TEMP light blink change from 2 Hz to 4 Hz during air bleeding.

- 23) Set the select lever to "N" range, and turn the ignition switch to OFF.
- 24) Set the select lever to "P" range to finish air bleeding.

19.ATF Filter

A: REMOVAL

NOTE:

The ATF filter is maintenance free.

- 1) Lift-up the vehicle.
- 2) Using ST, remove ATF filter.

ST 498545400 OIL FILTER WRENCH

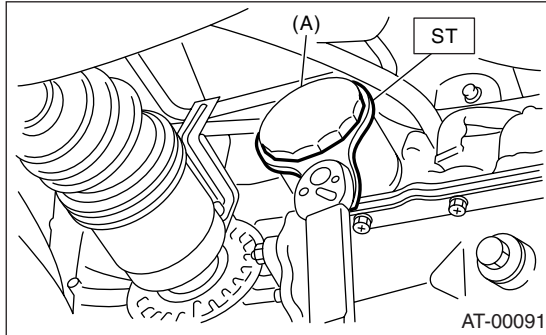

(A) ATF filter

B: INSTALLATION

- 1) Get new ATF filter and apply a thin coat of ATF to the oil seal.
- 2) Install ATF filter. Turn it by hand, being careful not to damage oil seal.
- 3) Using ST, tighten ATF filter.

Calculate ATF filter torque specifications using the following formula.

$$T2 = L2 / (L1 + L2) \times T1$$

T1: 14 N·m (1.4 kgf·m, 10.1 ft·lb)

[Required torque setting]

T2: Tightening torque

L1: ST length 78 mm (3.07 in)

L2: Torque wrench length

Example:

Torque wrench length mm (in)	Tightening torque N·m (kgf·m, ft·lb)
100 (3.94)	7.7 (0.79, 5.7)
150 (5.91)	9.0 (0.92, 6.7)
200 (7.87)	10 (1.0, 7.4)

NOTE:

Align ST with torque wrench while tightening ATF filter.

ST 498545400 OIL FILTER WRENCH

- 4) Add ATF.
- 5) Inspect level of ATF. <Ref. to 4AT-30, Automatic Transmission Fluid.>

C: INSPECTION

Check for rust, hole, ATF leaks, and other damage.

Transmission Control Module (TCM)

AUTOMATIC TRANSMISSION

20. Transmission Control Module (TCM)

A: REMOVAL

- 1) Disconnect the ground cable from battery.
- 2) Remove the lower cover and then disconnect the connector.
- 3) Remove the knee bolster.

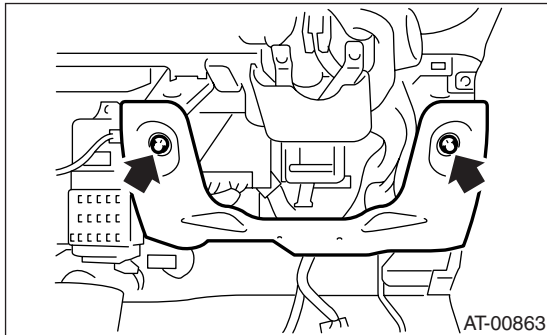

- 4) Disconnect the connectors from TCM.

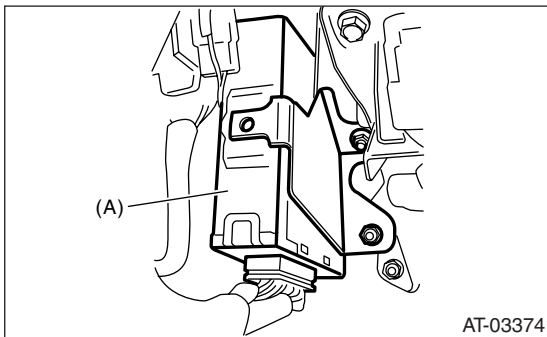

(A) Transmission control module (TCM)

- 5) Remove the TCM.

B: INSTALLATION

- 1) Install the TCM.

Tightening torque:

7.5 N·m (0.76 kgf-m, 5.5 ft-lb)

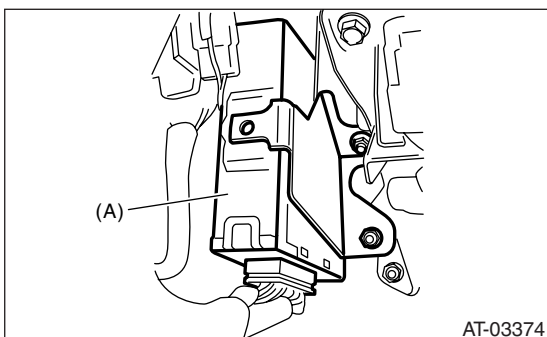

(A) Transmission control module (TCM)

- 2) Connect the connectors to TCM.
- 3) Install in the reverse order of removal.

4) If replacing the TCM, execute the advance operation of learning control promotion. <Ref. to 4AT(D)(diag)-15, FACILITATION OF LEARNING CONTROL, OPERATION, Subaru Select Monitor.>

21. ATF Cooler Pipe and Hose

A: REMOVAL

- 1) Set the vehicle on a lift.
- 2) Remove battery and washer tank.
- 3) Lift-up the vehicle.
- 4) Remove the under cover.
- 5) Disconnect ATF cooler hose from radiator.

NOTE:

- Do not remove with a screwdriver or other pointed tools.
- When the hose is difficult to remove, wrap a shop cloth around the hose to protect it. Turn it with pliers, and then pull directly out with your hand.

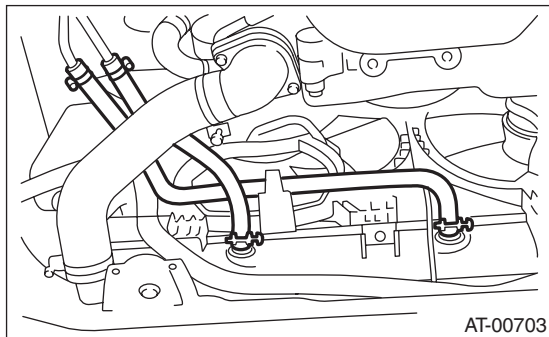

- 6) Disconnect ATF cooler hoses from pipes.

NOTE:

- Do not remove with a screwdriver or other pointed tools.
- When the hose is difficult to remove, wrap a shop cloth around the hose to protect it. Turn it with pliers, and then pull directly out with your hand.

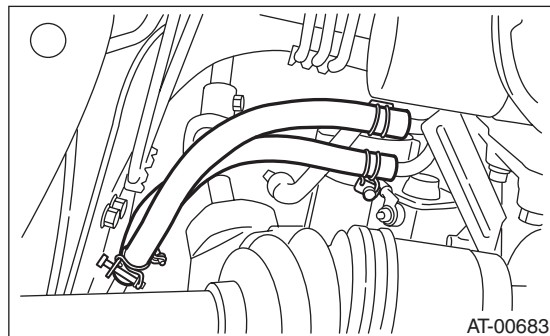

- 7) Remove ATF cooler pipe from frame.

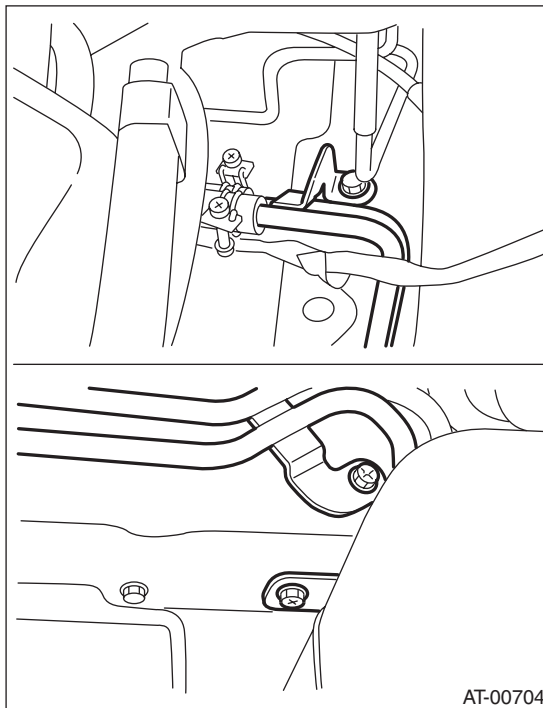

- 8) Remove the oil cooler inlet and outlet pipes.

NOTE:

When removing outlet pipe, be careful not to lose ball and spring used with retaining screw.

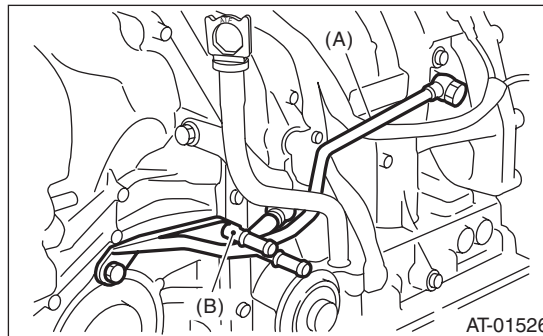

- (A) Inlet pipe
- (B) Outlet pipe

B: INSTALLATION

- 1) Install the oil cooler outlet and inlet pipes using a new aluminum washer.

ATF Cooler Pipe and Hose

AUTOMATIC TRANSMISSION

Tightening torque:

T1: 25 N·m (2.5 kgf-m, 18.4 ft-lb)

T2: 45 N·m (4.6 kgf-m, 33 ft-lb)

T3: 40 N·m (4.1 kgf-m, 30 ft-lb)

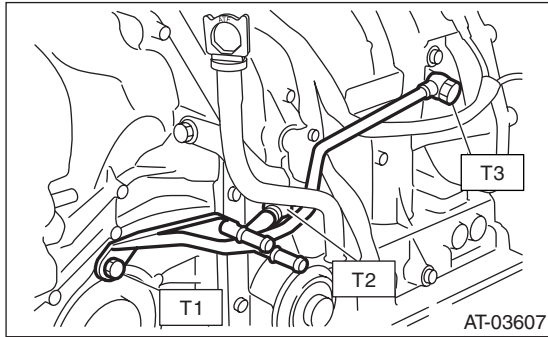

2) Install ATF cooler pipe to frame.

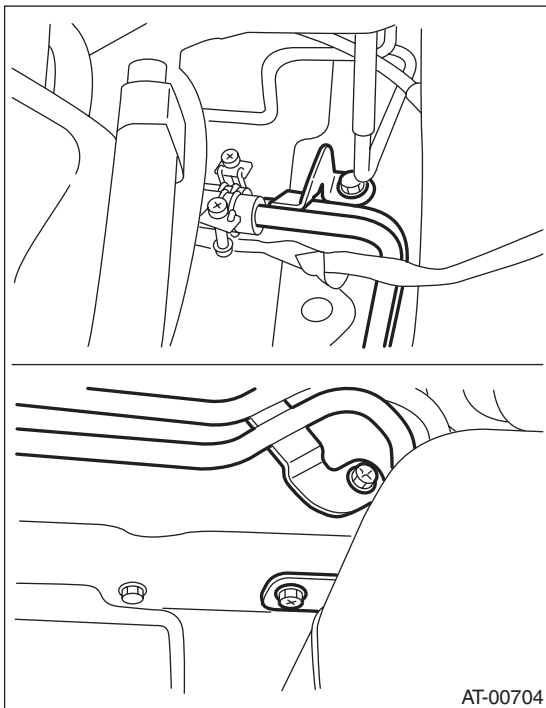

3) Connect ATF cooler hose to pipe transmission side.

NOTE:

- Install so that the hose is not folded over, excessively bent, or twisted.

- Be careful to insert the hose to the specified position.

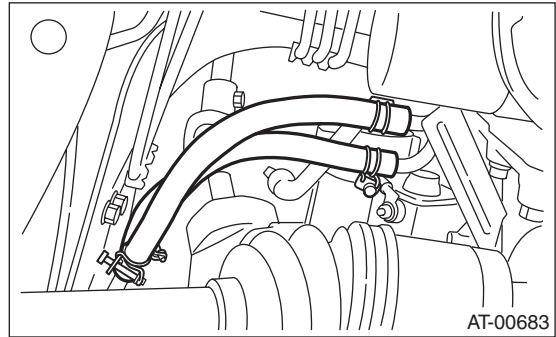

4) Connect ATF cooler hose to pipe of radiator side.

NOTE:

- Install so that the hose is not folded over, excessively bent, or twisted.
- Be careful to insert the hose to the specified position.

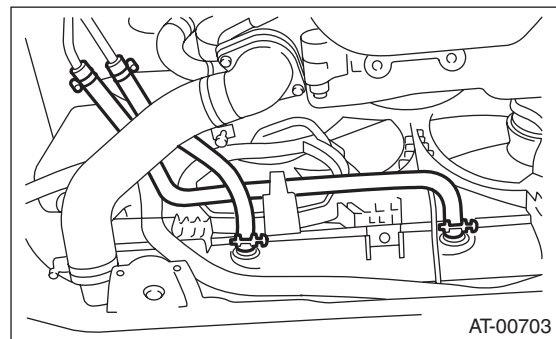

5) Install the under cover.

6) Install battery and washer tank.

7) Fill ATF. <Ref. to 4AT-30, Automatic Transmission Fluid.>

NOTE:

Make sure there are no ATF leaks in joints between the transmission, radiator, pipes, and hoses.

C: INSPECTION

Repair or replace any defective hoses, pipes, clamps, and washers found from the inspection below.

- 1) Check for ATF leaks in joints between the transmission, radiator, pipes, and hoses.
- 2) Check for deformed clamps.
- 3) Lightly bend the hose and check for cracks in the surface and other damage.
- 4) Pinch the hose with your fingers and check for poor elasticity. Also check for poor elasticity in the parts where the clamp was by pressing with your fingernail.
- 5) Check for peeling, cracks, and deformation at the tip of the hose.

22. Air Breather Hose

A: REMOVAL

1) Remove the air intake chamber. (Non-turbo model) <Ref. to IN(H4SO)-6, REMOVAL, Air Intake Chamber.>

2) Remove intercooler. (Turbo model) <Ref. to IN(H4DOTC)-11, REMOVAL, Intercooler.>

3) Disconnect the air breather hoses.

- Non-turbo model

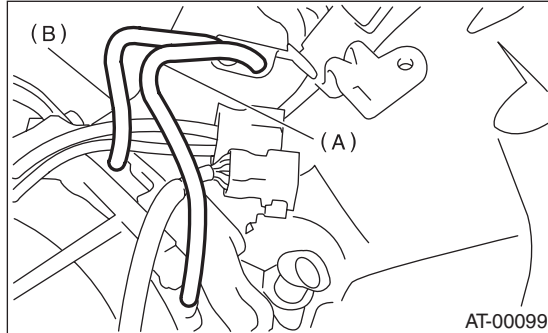

(A) Air breather hose (Transmission case)
(B) Air breather hose (Oil pump housing)

- Turbo model

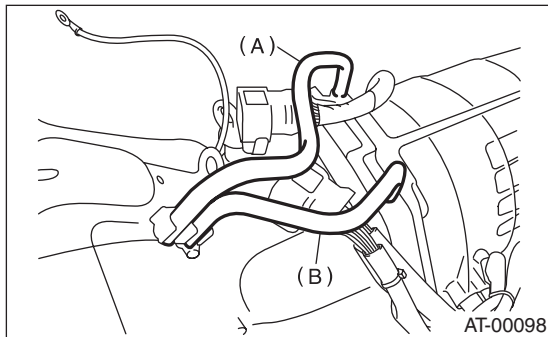

(A) Air breather hose (Transmission case)
(B) Air breather hose (Oil pump housing)

B: INSTALLATION

1) Install air breather hoses.

NOTE:

Install so that the hose is not folded over, excessively bent, or twisted.

- Non-turbo model

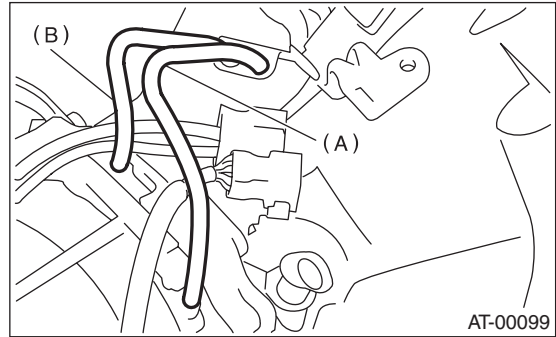

(A) Air breather hose (Transmission case)
(B) Air breather hose (Oil pump housing)

- Turbo model

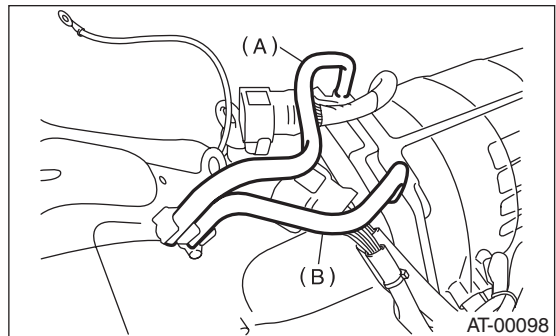

(A) Air breather hose (Transmission case)
(B) Air breather hose (Oil pump housing)

2) Install the air intake chamber. (Non-turbo model) <Ref. to IN(H4SO)-6, INSTALLATION, Air Intake Chamber.>

3) Install intercooler. (Turbo model) <Ref. to IN(H4DOTC)-11, INSTALLATION, Intercooler.>

C: INSPECTION

Make sure the hose is not cracked or clogged.

23. Oil Charge Pipe

A: REMOVAL

- 1) Remove the air intake chamber. (Non-turbo model) <Ref. to IN(H4SO)-6, REMOVAL, Air Intake Chamber.>
- 2) Remove intercooler. (Turbo model) <Ref. to IN(H4DOTC)-11, REMOVAL, Intercooler.>
- 3) Remove the oil charge pipe, and remove the O-ring from the flange face.

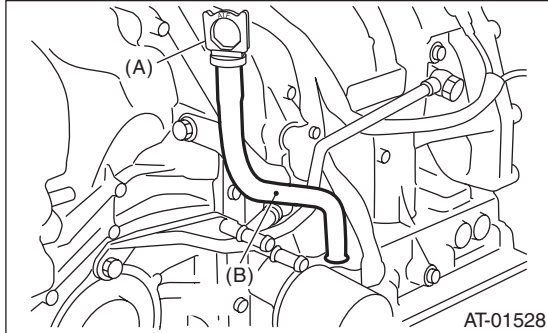

- (A) Oil level gauge
- (B) Oil charge pipe

B: INSTALLATION

- 1) Install the oil charge pipe with new O-ring.

Tightening torque:

41 N·m (4.2 kgf·m, 30.2 ft·lb)

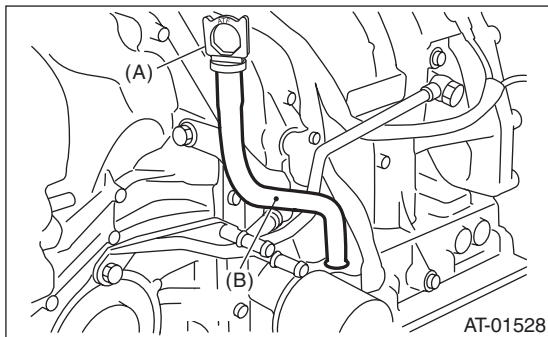

- (A) Oil level gauge
- (B) Oil charge pipe

- 2) Install the air intake chamber. (Non-turbo model) <Ref. to IN(H4SO)-6, INSTALLATION, Air Intake Chamber.>
- 3) Install intercooler. (Turbo model) <Ref. to IN(H4DOTC)-11, INSTALLATION, Intercooler.>

C: INSPECTION

Make sure the oil charge pipe is not deformed or otherwise damaged.

24. Torque Converter Clutch Assembly

A: REMOVAL

- 1) Remove the transmission assembly from the vehicle. <Ref. to 4AT-38, REMOVAL, Automatic Transmission Assembly.>
- 2) Extract the torque converter clutch and oil pump shaft horizontally.

NOTE:

Be careful not to scratch the bushing inside the oil pump shaft.

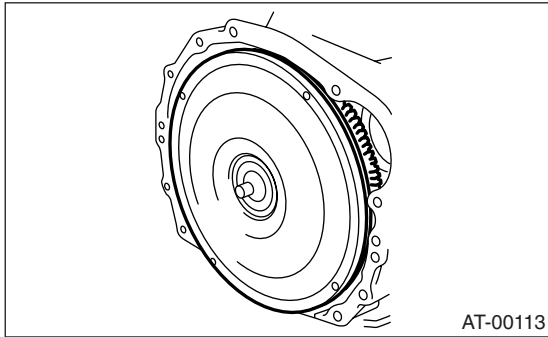

- 3) Remove the input shaft.

NOTE:

When the torque converter clutch assembly is removed, the input shaft will come out.

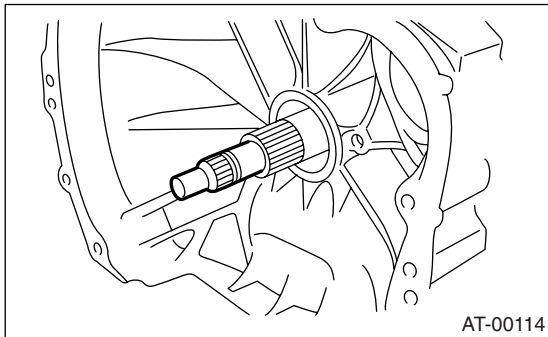

- 4) Remove the clip from torque converter clutch.

B: INSTALLATION

- 1) Install the clip to torque converter clutch.
- 2) Install the oil pump shaft to the torque converter clutch, and then check the clip fits securely in its groove.
- 3) Insert the input shaft while rotating it lightly by hand, and then check the protrusion amount.

Normal protrusion amount A:
50 — 55 mm (1.97 — 2.17 in)

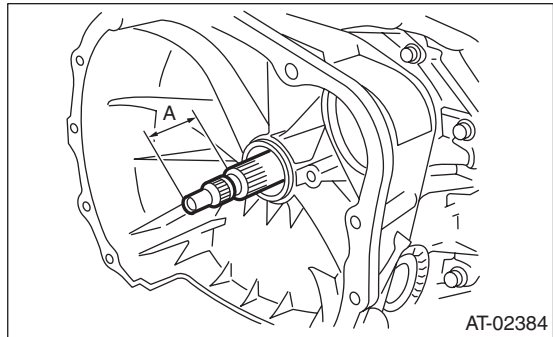

- 4) Holding the torque converter clutch assembly by hand, carefully install it to the converter case. Be careful not to damage the bushing. Also avoid undue contact between the oil pump shaft bushing and stator shaft portion of the oil pump cover.
- 5) Rotate the shaft lightly by hand to engage the splines securely.

Dimension A:

2.7 — 2.9 mm (0.106 — 0.114 in)

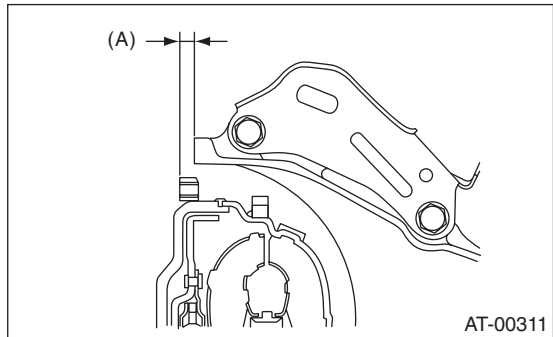

(A) Dimension A

- 6) Install the transmission assembly to vehicle. <Ref. to 4AT-40, INSTALLATION, Automatic Transmission Assembly.>

C: INSPECTION

Make sure the ring gear is not damaged and that the protrusion on the edge of the torque converter clutch is not deformed or otherwise damaged.

Extension Case

AUTOMATIC TRANSMISSION

25.Extension Case

A: REMOVAL

- 1) Remove the transmission assembly.
<Ref. to 4AT-38, REMOVAL, Automatic Transmission Assembly.>
- 2) Remove the rear vehicle speed sensor.
 - MP-T model

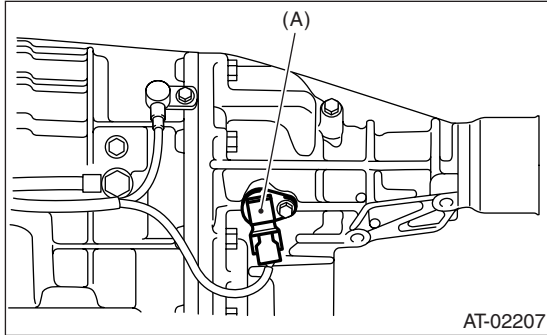

(A) Rear vehicle speed sensor

- VTD model

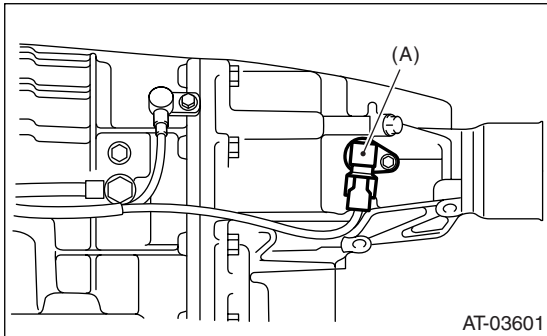

(A) Rear vehicle speed sensor

- 3) Separate transmission case and extension case sections.

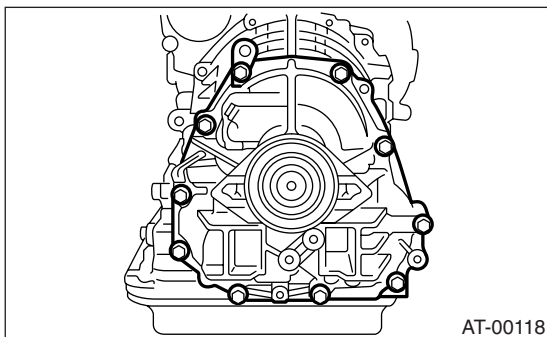

B: INSTALLATION

- 1) Attach the selected thrust needle bearing to the end surface of reduction drive gear with vaseline.

NOTE:

Install thrust needle bearing in the correct direction.

- 2) Install new gasket.

- 3) Install the extension case to the transmission case.

- 4) Tighten bolts to secure the case.

Tightening torque:

25 N·m (2.5 kgf·m, 18.4 ft·lb)

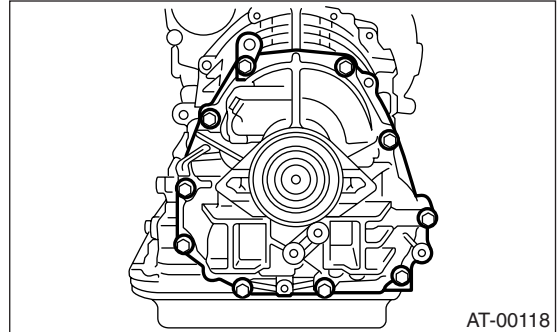

- 5) Install the rear vehicle speed sensor.

Tightening torque:

7 N·m (0.7 kgf·m, 5.1 ft·lb)

- MP-T model

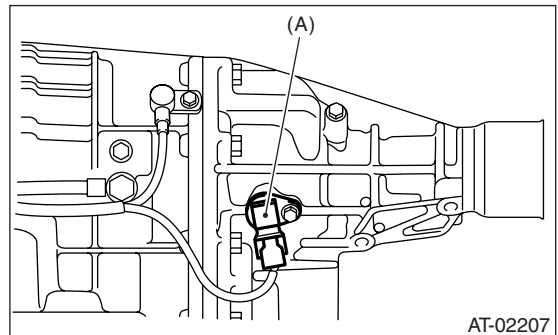

(A) Rear vehicle speed sensor

- VTD model

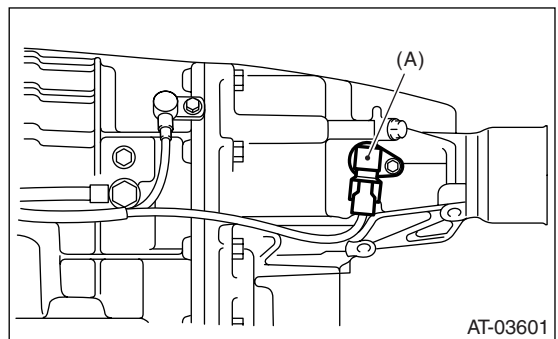

(A) Rear vehicle speed sensor

- 6) Install the transmission assembly.
<Ref. to 4AT-40, INSTALLATION, Automatic Transmission Assembly.>

C: DISASSEMBLY

1. MP-T MODEL

1) Take out the transfer clutch by lightly tapping the end of the rear drive shaft.

NOTE:

Be careful not to damage the oil seal in the extension.

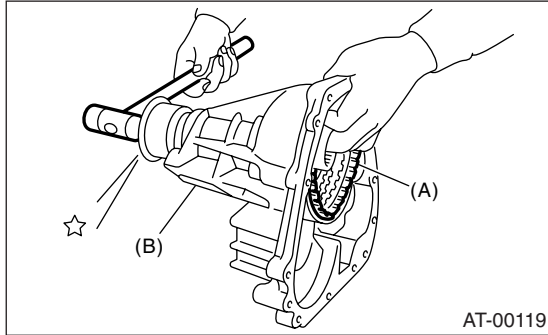

(A) Transfer clutch
(B) Extension case

2) Remove the transmission clutch pipe without deforming pipe.

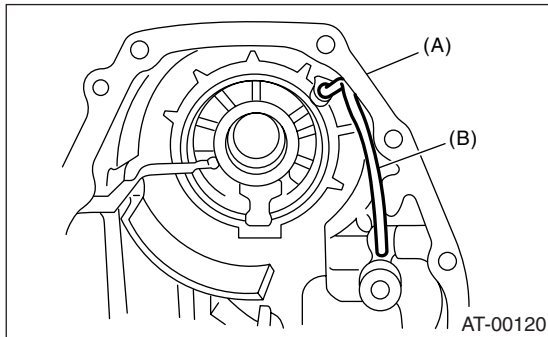

(A) Extension case
(B) Transfer clutch pipe

3) Remove the dust cover from extension case.

4) Remove the oil seal from extension case.

2. VTD MODEL

1) Remove snap ring using ST1, ST2, ST3 and a press.

ST1 398673600 COMPRESSOR

ST2 498627100 SEAT

ST3 398663600 PLIERS

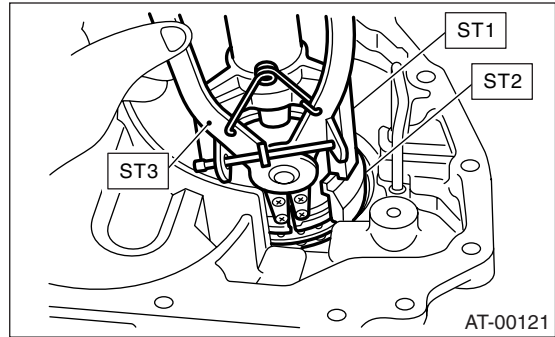

2) Remove test plug.

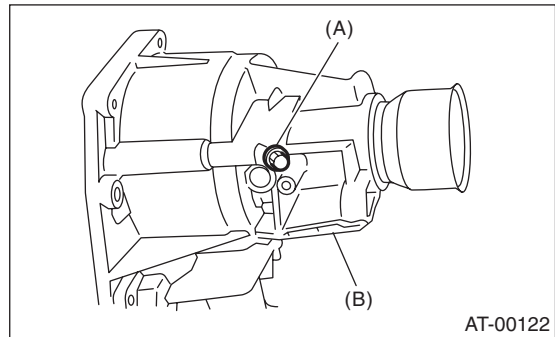

(A) Test plug
(B) Extension case

3) Remove clutch piston using compressed air.

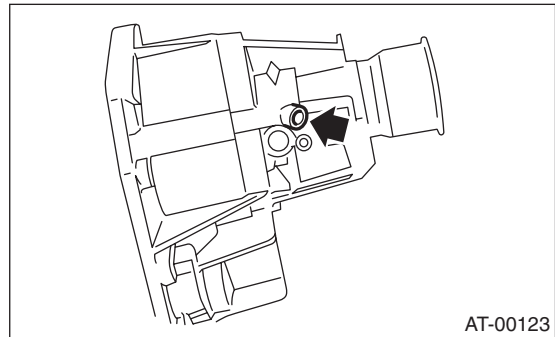

4) Pay attention, not to deform pipe, and remove transfer clutch pipe.

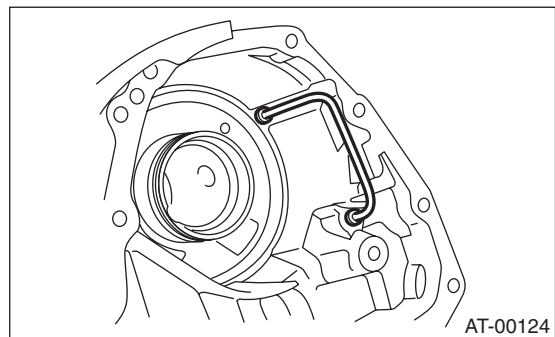

5) Remove the dust cover from the extension case.
6) Remove the oil seal from the extension case.

Extension Case

AUTOMATIC TRANSMISSION

D: ASSEMBLY

1. MP-T MODEL

1) Using the ST and a press, press in a new oil seal.

ST 498057300 INSTALLER

2) Press in the dust cover.

3) Install the transfer clutch pipe to extension case without deforming pipe.

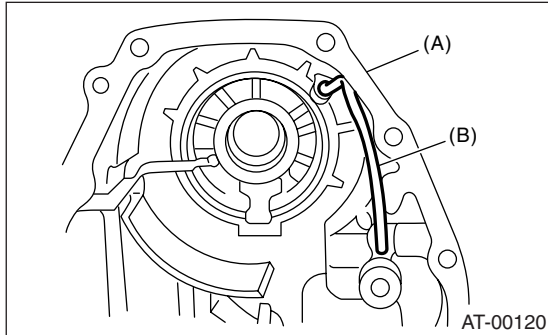

(A) Extension case
(B) Transfer clutch pipe

4) Install the transfer clutch assembly to the case.

NOTE:

- Be careful not to damage the seal rings.
- Insert the clutch assembly fully into position until the bearing shoulder bottoms.

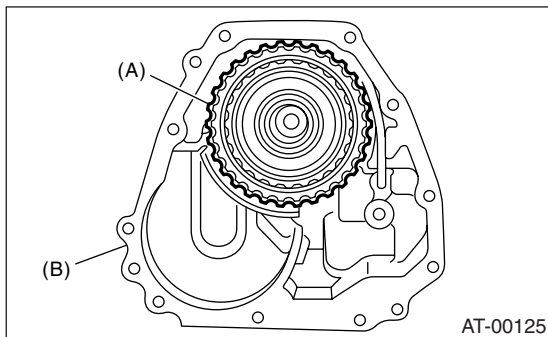

(A) Transfer clutch
(B) Extension case

2. VTD MODEL

1) Press new oil seal using ST and a press.

ST 498057300 INSTALLER

2) Press dust cover.

3) Install the transfer clutch pipe onto the extension case, taking care not to deform the pipe.

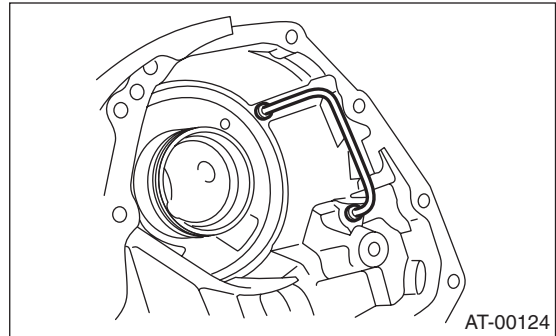

4) Apply ATF to new O-ring and install the test plug.

Tightening torque:

13 N·m (1.3 kgf-m, 9.6 ft-lb)

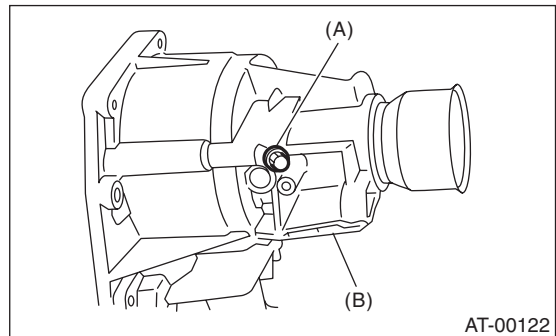

(A) Test plug
(B) Extension case

5) Insert the multi-plate clutch, drive plates, driven plates, and spring retainer.

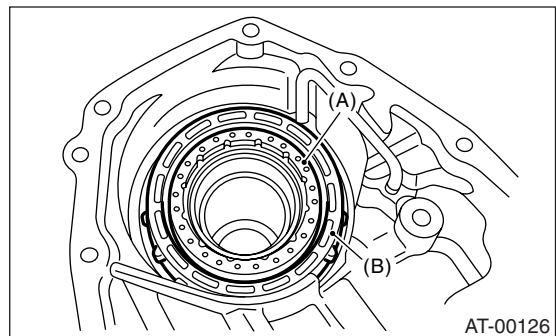

(A) Spring retainer
(B) Multi-plate clutch (LSD) piston ASSY

6) Install the snap ring using special tools 1, 2, and 3.

ST1 398673600 COMPRESSOR

ST2 498627100 SEAT

ST3 398663600 PLIERS

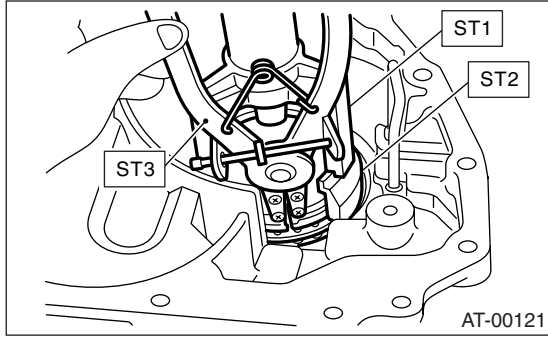

E: INSPECTION

- Use forced air to make sure the transfer pipe and extension case routes are not clogged and do not leak.

- Measure the extension end play and adjust it to within specifications.

MP-T model <Ref. to 4AT-75, MP-T MODEL, ADJUSTMENT, Transfer Clutch.>

VTD model <Ref. to 4AT-76, VTD MODEL, ADJUSTMENT, Transfer Clutch.>

Transfer Clutch

AUTOMATIC TRANSMISSION

26. Transfer Clutch

A: REMOVAL

1) Remove the transmission assembly from vehicle. <Ref. to 4AT-38, REMOVAL, Automatic Transmission Assembly.>

2) Remove the extension case and remove the transfer clutch. <Ref. to 4AT-68, REMOVAL, Extension Case.> <Ref. to 4AT-69, DISASSEMBLY, Extension Case.>

B: INSTALLATION

1) Select the thrust needle bearing. <Ref. to 4AT-75, ADJUSTMENT, Transfer Clutch.>

2) Install the transfer clutch assembly to the case.

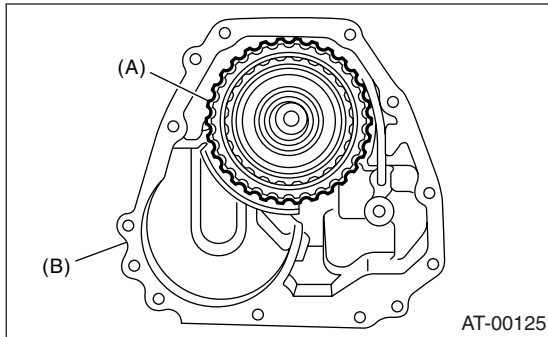

(A) Transfer clutch
(B) Extension case

3) Replace with new gasket, and tighten bolts to secure the case.

Tightening torque:

25 N·m (2.5 kgf·m, 18.4 ft·lb)

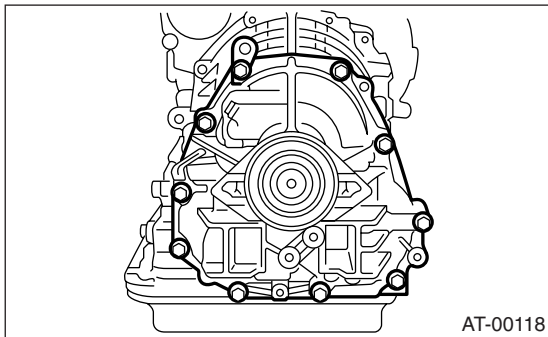

4) Install the transmission assembly to vehicle. <Ref. to 4AT-40, INSTALLATION, Automatic Transmission Assembly.>

C: DISASSEMBLY

1) Remove the seal ring.

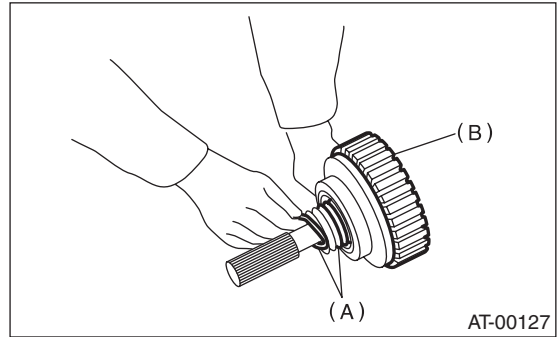

(A) Seal ring
(B) Transfer clutch

2) Using a press and ST, remove the ball bearing.
ST 498077600 REMOVER

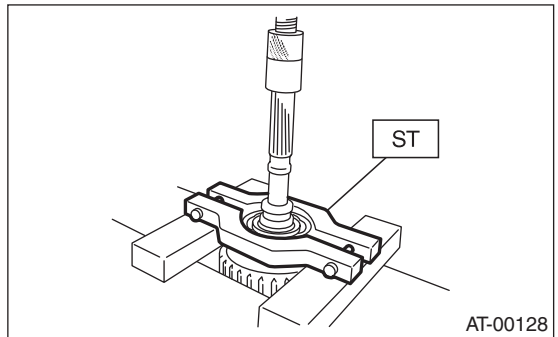

3) Remove the snap ring, and take out the pressure plate, drive plates, and driven plates.

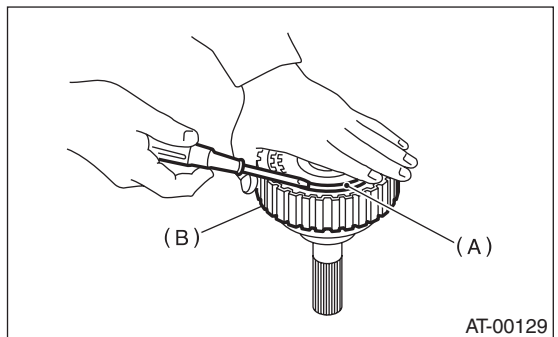

(A) Snap ring
(B) Transfer clutch

4) Remove the snap ring with ST1, ST2 and ST3, and take out the return spring and transfer clutch piston seal.

ST1 399893600 PLIERS
ST2 398673600 COMPRESSOR

Transfer Clutch

AUTOMATIC TRANSMISSION

ST3 398623600 SEAT

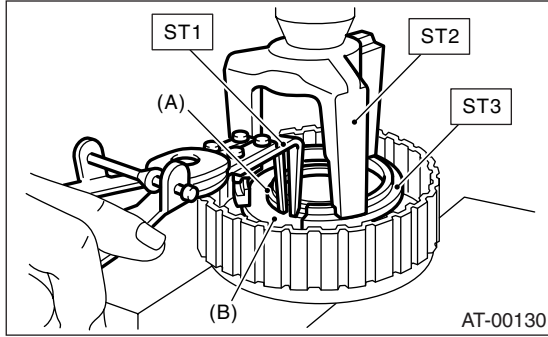

- (A) Snap ring
- (B) Transfer piston seal

2) Install return spring to transfer piston.

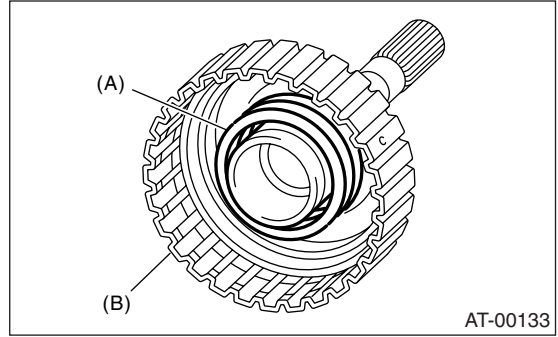

- (A) Return spring
- (B) Rear drive shaft

5) Apply compressed air to the rear drive shaft to remove the piston.

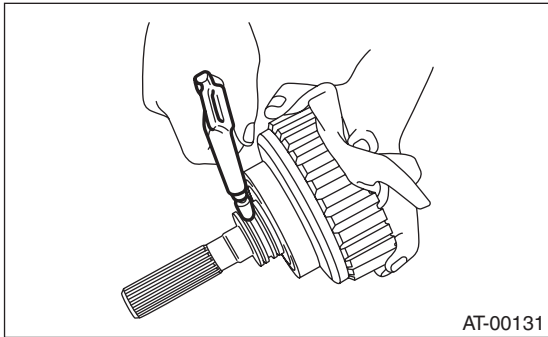

AT-00131

3) Apply ATF to the transfer clutch piston seal lip and install it.

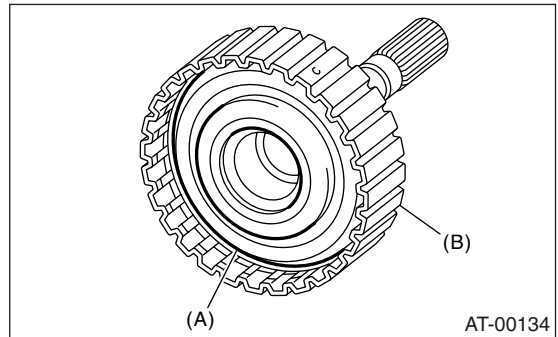

- (A) Transfer clutch piston seal
- (B) Rear drive shaft

D: ASSEMBLY

1) Install the transfer clutch piston.

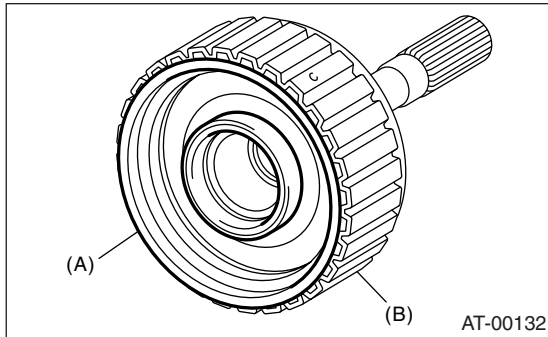

- (A) Transfer clutch piston
- (B) Rear drive shaft

4) Install ST to rear drive shaft.

ST 499257300 SNAP RING OUTER GUIDE

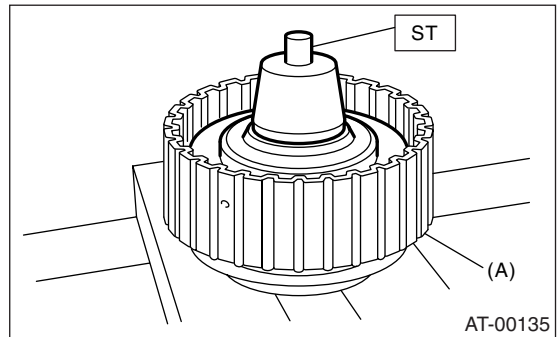

- (A) Rear drive shaft

5) Install snap ring to ST.

Transfer Clutch

AUTOMATIC TRANSMISSION

ST 499257300 SNAP RING OUTER GUIDE

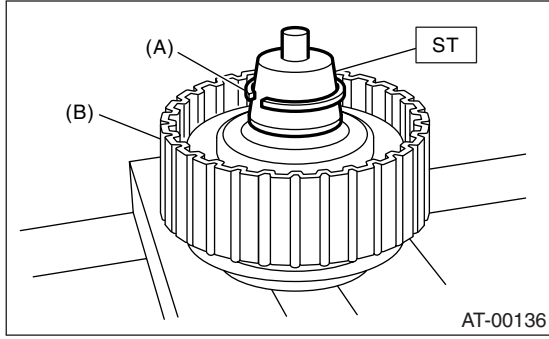

- (A) Snap ring
- (B) Transfer clutch

6) Using ST1 and ST2, install snap ring to rear drive shaft.

ST1 499257300 SNAP RING OUTER GUIDE
ST2 499247400 INSTALLER

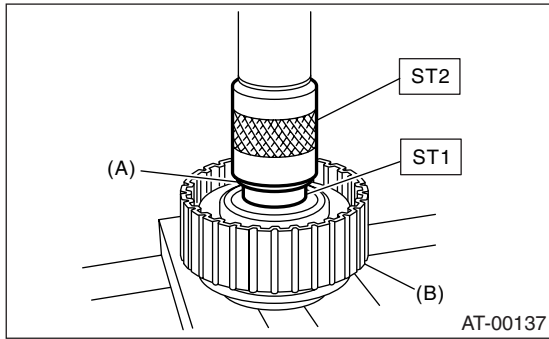

- (A) Snap ring
- (B) Transfer clutch

7) Install the driven plates, drive plates, pressure plate and snap ring.

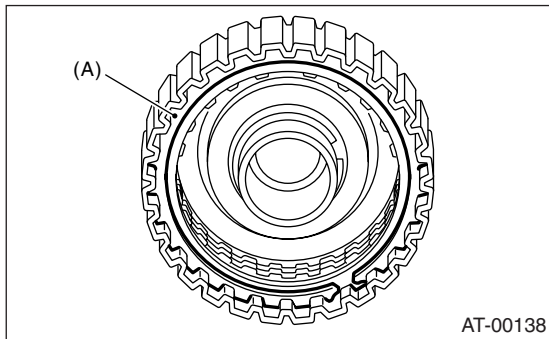

- (A) Snap ring

8) Apply compressed air to see if the assembled parts move smoothly.

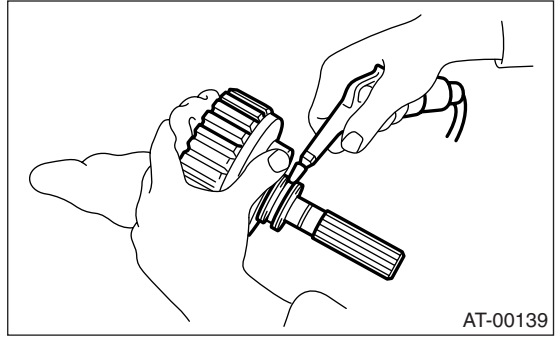

9) Check clearance between snap ring and pressure plate. <Ref. to 4AT-75, INSPECTION, Transfer Clutch.>

10) Press-fit a new ball bearing with ST.
ST 899580100 INSTALLER

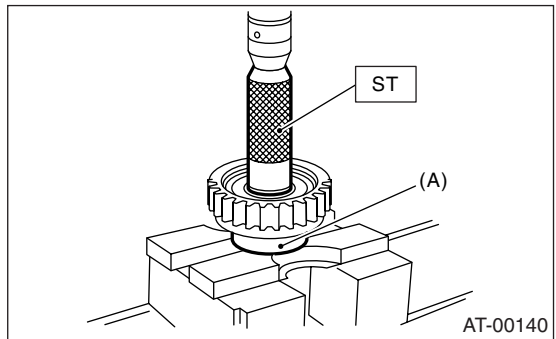

- (A) Ball bearing

11) Coat a new seal ring with vaseline, and install it in the seal ring groove of the shaft.

NOTE:

Do not expand the seal ring excessively when installing.

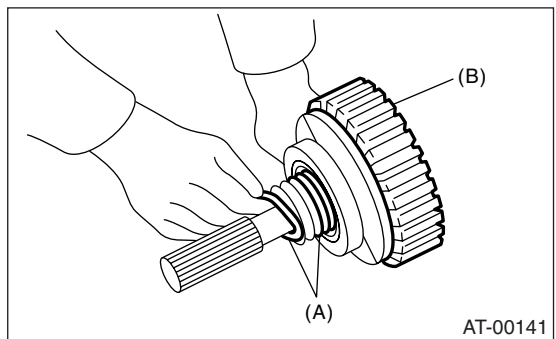

- (A) Snap ring
- (B) Transfer clutch

12) Install the transfer clutch assembly without damaging seal ring.

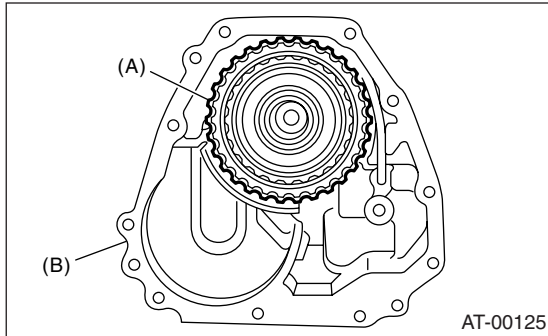

- (A) Transfer clutch
- (B) Extension case

E: INSPECTION

- Check the drive plate facing for wear and damage.
- Check the snap ring for wear, return spring for permanent set and breakage, and return spring for deformation.
- Check the D-ring for damage.
- Measure the extension end play and adjust it to within specifications. <Ref. to 4AT-75, ADJUSTMENT, Transfer Clutch.>

- 1) Inspect clearance between snap ring and pressure plate.
- 2) Before measuring clearance, place the same thickness of shim on both sides to prevent pressure plate from tilting.
- 3) If the clearance is not within specification, adjust it by selecting a suitable pressure plate on the transfer clutch piston side. If it exceeds the service limit, replace the drive plate with new one and adjust it within the specification by selecting the pressure plate.

Initial standard:

0.7 — 1.1 mm (0.028 — 0.043 in)

Limit thickness:

1.6 mm (0.063 in)

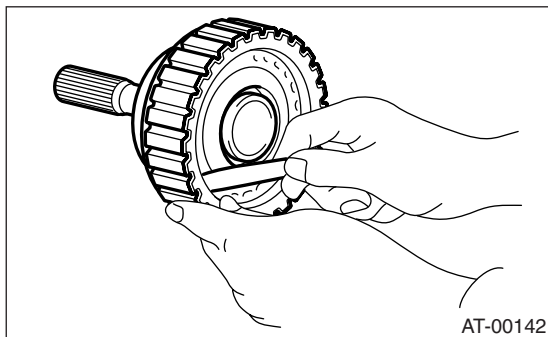

Pressure plates	
Part No.	Thickness mm (in)
31593AA151	3.3 (0.130)
31593AA161	3.7 (0.146)
31593AA171	4.1 (0.161)
31593AA181	4.5 (0.177)

4) Check if the tight corner braking does not occur when the vehicle is started with steering wheel held at fully turned position. If tight corner braking occurs, perform the following procedures.

- (1) With the steering wheel held at fully turned position, drive the vehicle in "D" range and with vehicle speed at approx. 5 km/h (3 MPH) in both clockwise and counterclockwise directions for approx. ten times each, while repeating acceleration and braking intermittently.
- (2) If the tight corner braking still persists, drive the vehicle again in a circle for several laps.

F: ADJUSTMENT

1. MP-T MODEL

1) Using the ST, measure the distance "A" from the end surface of ST to the end surface of rear drive shaft.

ST 398643600 GAUGE

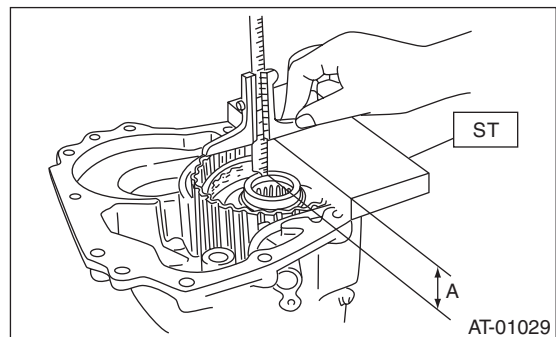

A: Measured value

2) Using the ST1 and ST2, measure the distance "B" from the transmission case mating surface to the end surface of ST.

ST1 398643600 GAUGE

Transfer Clutch

AUTOMATIC TRANSMISSION

ST2 499577000 GAUGE

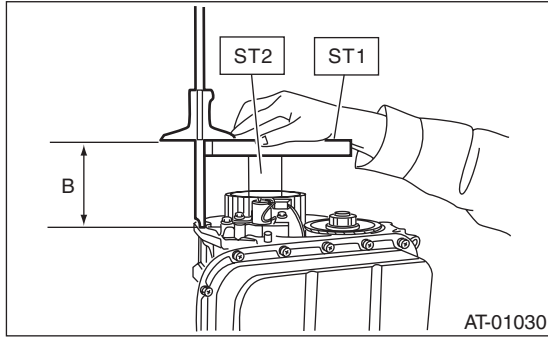

B: Measured value

3) Calculation formula:

NOTE:

Calculate "T":

$$T = A - B + 35.4 \text{ mm}$$

$$[T = A - B + 1.3937 \text{ in}]$$

T: Thrust needle bearing thickness

A: Distance from the end surface of ST to the end surface of rear drive shaft

B: Distance from the mating surface of transmission case to the end surface of ST

Example:

When, A = 33.6 mm (1.3228 in), B = 65.05 mm (2.5610 in)

$$T = 33.6 - 65.05 + 35.4 = 3.95$$

$$[T = 1.3228 - 2.5610 + 1.3937 = 0.1555]$$

After calculation, the value of "T" becomes 3.95 mm (0.1555 in), therefore select bearing thickness of 3.8 mm (0.150 in).

NOTE:

Calculation formula for "T" is applied when measuring using ST (398643600 GAUGE, 499577000 GAUGE). When not using ST, apply

$$T = (A - \alpha + 0.45 \text{ mm}) - (B - \beta) - H$$

$$[T = (A - \alpha + 0.0177 \text{ in}) - (B - \beta) - H]$$

T: Thrust needle bearing thickness

A: Distance from the end surface of collar as substitute for ST to the end surface of reduction drive shaft

B: Distance from the mating surface of transmission case to the end surface of collar as substitute for ST

α : Collar thickness used when measuring "A"

β : Collar thickness used when measuring "B"

0.45 (0.0177): Gasket thickness (mm (in))

H: Shim clearance

Thrust needle bearing	
Part No.	Thickness mm (in)
806536020	3.8 (0.150)
806535030	4.0 (0.157)
806535040	4.2 (0.165)
806535050	4.4 (0.173)
806535060	4.6 (0.181)
806535070	4.8 (0.189)
806535090	5.0 (0.197)

2. VTD MODEL

1) Insert the rear driveshaft into the reduction drive gear and center differential assembly.

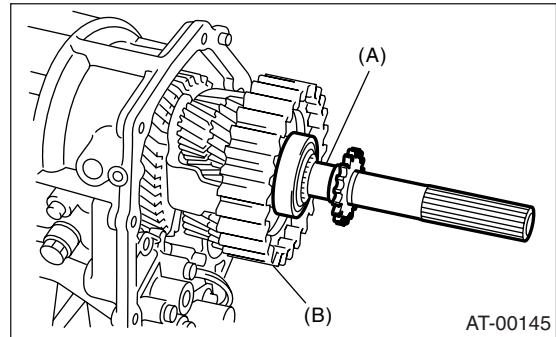

(A) Rear drive shaft

(B) Center differential carrier

2) Using the ST, measure the distance "A" from the end surface of ST to the ball bearing outer ring contact surface of rear drive shaft.

ST 398643600 GAUGE

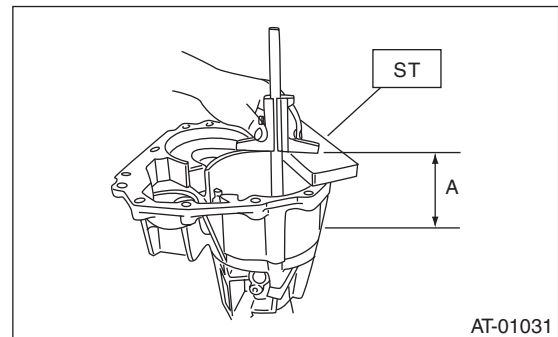

A Measured value

3) Using the ST, measure the distance "B" from the mating surface of transmission case to the end surface of ST.

ST 398643600 GAUGE

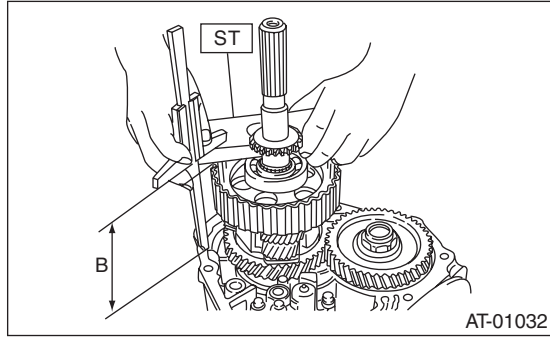

B Measured value

4) Formula:

NOTE:

Calculation of “T”:

When clearances are 0.05 mm (0.0020 in), select up to four adjusting shims from the table, suitable for clearance value.

When clearances are 0.05 mm (0.0020 in)

$$T = A - B + 0.40 \text{ mm}$$

$$[T = A - B + 0.0157 \text{ in}]$$

When clearances are 0.25 mm (0.0098 in)

$$T = A - B + 0.20 \text{ mm}$$

$$[T = A - B + 0.0079 \text{ in}]$$

T: Shim clearance

A: Distance from the end surface of ST to the ball bearing outer ring contact surface of rear drive shaft

B: Distance from the mating surface of transmission case to the end surface of ST

T: Shim thickness

0.05 — 0.25 mm (0.0020 — 0.0098 in)

Example:

When, A = 90.50 mm (3.5630 in), B = 90.35 mm (3.5571 in)

Calculation for 0.05 mm (0.0020 in) of clearance

$$T = 90.50 - 90.35 + 0.4 = 0.55$$

$$[T = 3.5630 - 3.5571 + 0.0157 = 0.0216]$$

Calculation when clearance is 0.25 mm (0.0098 in)

$$T = 90.50 - 90.35 + 0.2 = 0.35$$

$$[T = 3.5630 - 3.5571 + 0.0079 = 0.0138]$$

NOTE:

Calculation formula for “T” is applied when measuring using ST (398643600 GAUGE). When not using ST, apply

$$T = (A - \alpha + 0.45 \text{ mm}) - (B - \beta) - H$$

$$[T = (A - \alpha + 0.0177 \text{ in}) - (B - \beta) - H]$$

T: Thrust needle bearing thickness

A: Distance from the end surface of collar as substitute for ST to the rear drive shaft ball bearing outer ring contact surface

B: Distance from the mating surface of transmission case to the end surface of collar as substitute for ST

α : Collar thickness used when measuring “A”

β : Collar thickness used when measuring “B”

0.45 (0.0177): Gasket thickness (mm (in))

H: Shim clearance

After calculation, the value of “T” becomes between 0.35 mm (0.0138 in) and 0.55 mm (0.0216 in), therefore select two shims with thickness of 0.2 mm (0.010 in) or one shim with thickness of 0.5 mm (0.020 in).

Adjusting shim	
Part No.	Thickness mm (in)
33281AA001	0.2 (0.008)
33281AA011	0.5 (0.020)

Multi-plate Clutch

AUTOMATIC TRANSMISSION

27. Multi-plate Clutch

A: REMOVAL

Remove multi-plate clutch following the same instructions as for the extension case. <Ref. to 4AT-68, REMOVAL, Extension Case.>

B: INSTALLATION

Install multi-plate clutch following the same instructions as for the extension case. <Ref. to 4AT-68, INSTALLATION, Extension Case.>

C: INSPECTION

- Inspect drive plate facing for wear and damage.
- Make sure snap ring is not worn and return spring has no permanent distortion, damage, or deformation.
- Inspect D-ring for damage.
- Measure multi-plate clutch clearance and adjust it to within the specification range. <Ref. to 4AT-78, ADJUSTMENT, Multi-plate Clutch.>

D: ADJUSTMENT

1) Install the drive plate and driven plate to center differential carrier.

2) Using the ST, measure the distance “A” from the end surface of ST to multi-plate clutch piston.

ST 398643600 GAUGE

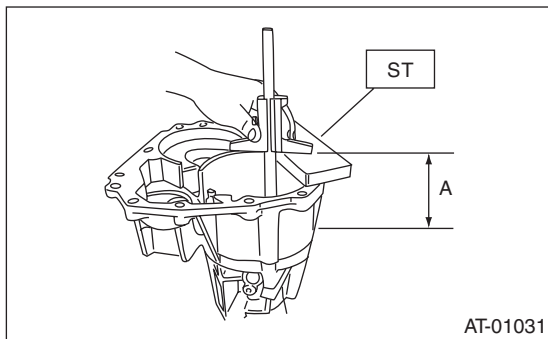

A Measured value

3) Using the ST, measure the height “B” from the mating surface of transmission case to the end surface of ST.

ST 398744300 GAUGE

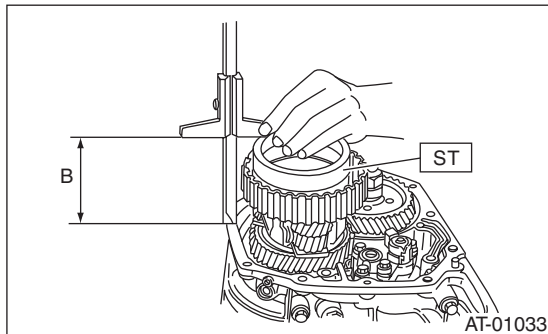

B Measured value

4) Calculation formula:

$$T = A - B + 0.45 \text{ mm}$$

$$[T = A - B + 0.0177 \text{ in}]$$

NOTE:

• Calculation formula for “T” is applied when measuring using ST (398643600 GAUGE, 398744300 GAUGE). When not using ST, apply

$$T = (A - \alpha + 0.45 \text{ mm}) - (B - \beta)$$

$$[T = (A - \alpha + 0.0177 \text{ in}) - (B - \beta)]$$

T: Thrust needle bearing thickness

A: Distance from the end surface of collar as substitute for ST to multi-plate clutch piston

B: Distance from the mating surface of transmission case to the end surface of collar as substitute for ST

α : Collar thickness used when measuring “A”

β : Collar thickness used when measuring “B”

0.45 (0.0177): Gasket thickness (mm (in))

• Measure multi-plate clutch driven and drive plate thickness to find the clearance between measurement value and “T”.

Standard value:

0.2 — 0.6 mm (0.008 — 0.024 in)

Limit value:

1.6 mm (0.063 in)

If outside the standard value, replace the plate set (drive and driven plate). Select a multi-plate clutch piston side adjustment plate that will bring clearance within the standard value.

Obtainable driven plate	
Part No.	Thickness mm (in)
31589AA041	1.6 (0.063)
31589AA050	2.0 (0.079)
31589AA060	2.4 (0.094)
31589AA070	2.8 (0.110)

28.Rear Drive Shaft

A: REMOVAL

- 1) Remove transmission assembly. <Ref. to 4AT-38, REMOVAL, Automatic Transmission Assembly.>
- 2) Remove rear wheel speed sensor and separate extension case from transmission case. <Ref. to 4AT-68, REMOVAL, Extension Case.>
- 3) Pull out the rear driveshaft from the center differential assembly.

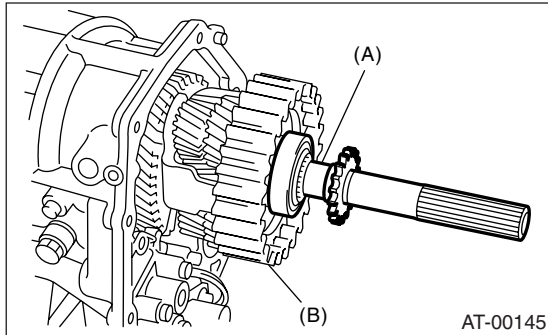

- (A) Rear driveshaft
- (B) Center differential carrier

- 4) Remove drive plate and driven plate.

B: INSTALLATION

- 1) Select the appropriate shim. <Ref. to 4AT-76, VTD MODEL, ADJUSTMENT, Transfer Clutch.>
- 2) Install drive plate and driven plate.
- 3) Insert rear driveshaft into the center differential assembly.
- 4) Join transmission case and extension case. Install rear wheel speed sensor. <Ref. to 4AT-68, INSTALLATION, Extension Case.>
- 5) Install transmission assembly. <Ref. to 4AT-40, INSTALLATION, Automatic Transmission Assembly.>

C: DISASSEMBLY

- 1) Using a press, remove revolution gear.

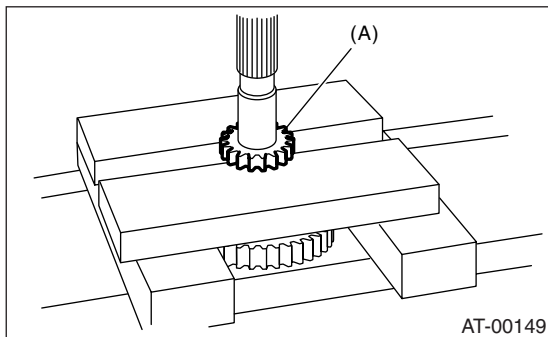

- (A) Revolution gear

- 2) Using a press, remove the front and rear side ball bearings and clutch hub.

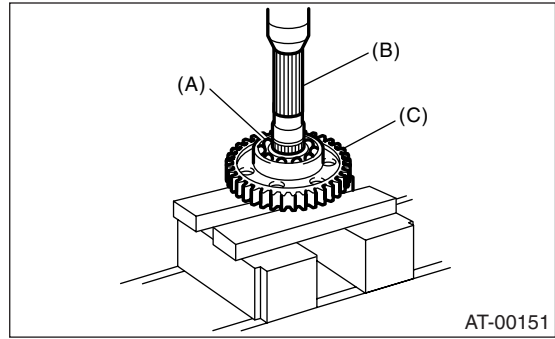

- (A) Rear ball bearing
- (B) Rear driveshaft
- (C) Clutch hub

D: ASSEMBLY

Assemble in the reverse order of disassembly.

NOTE:

- Use a new revolution gear and ball bearings.
- Make sure the clutch hub is oriented in the correct direction.

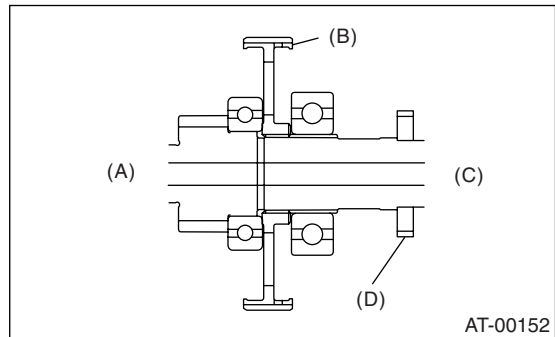

- (A) Front side
- (B) Clutch hub
- (C) Rear side
- (D) Revolution gear

E: INSPECTION

- Inspect parts to make sure there are no holes, cuts, and that they are not dusty.
- Inspect extension end play and adjust it to within the standard value. <Ref. to 4AT-76, VTD MODEL, ADJUSTMENT, Transfer Clutch.>

Reduction Driven Gear

AUTOMATIC TRANSMISSION

29.Reduction Driven Gear

A: REMOVAL

1. MP-T MODEL

- 1) Remove the transmission assembly from the vehicle. <Ref. to 4AT-38, REMOVAL, Automatic Transmission Assembly.>
- 2) Remove rear vehicle speed sensor, and separate the transmission case and extension case. <Ref. to 4AT-68, REMOVAL, Extension Case.>
- 3) Set the range select lever to "P".
- 4) Straighten the staked portion, and remove the lock nut.

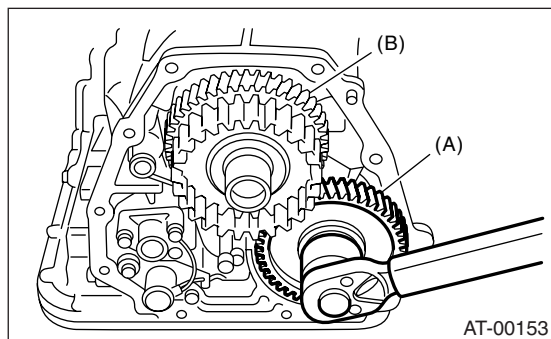

- (A) Reduction driven gear
- (B) Reduction drive gear

- 5) Using the ST1 and ST2, extract the reduction driven gear.

ST1 499737000 PULLER
ST2 899524100 PULLER SET

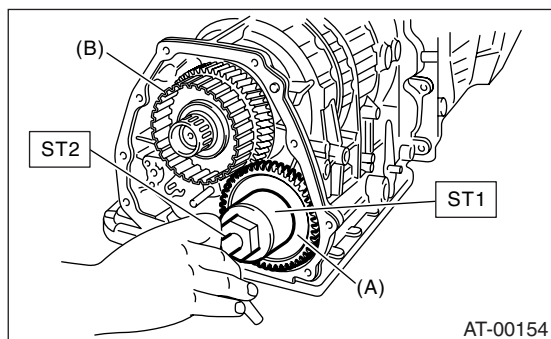

- (A) Reduction driven gear
- (B) Reduction drive gear

2. VTD MODEL

- 1) Remove the transmission assembly from the vehicle. <Ref. to 4AT-38, REMOVAL, Automatic Transmission Assembly.>
- 2) Remove rear vehicle speed sensor, and separate the transmission case and extension case. <Ref. to 4AT-68, REMOVAL, Extension Case.>
- 3) Remove the rear drive shaft. <Ref. to 4AT-79, REMOVAL, Rear Drive Shaft.>

- 4) Set the range select lever to "P".
- 5) Straighten the staked portion, and remove the lock nut.

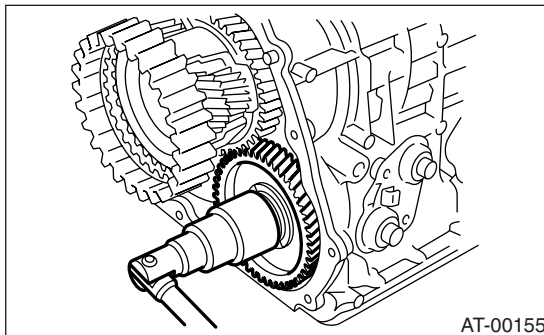

- 6) Using the ST1 and ST2, extract the reduction driven gear.

ST1 499737000 PULLER
ST2 899524100 PULLER SET

- 7) Pull out the center differential assembly. <Ref. to 4AT-84, REMOVAL, Center Differential Carrier.>

B: INSTALLATION

1. MP-T MODEL

- 1) Set the select lever to "P" range.
- 2) Using a plastic hammer, install reduction driven gear assembly and new washer, and tighten new drive pinion lock nut.

Tightening torque:

100 N·m (10.2 kgf-m, 73.8 ft-lb)

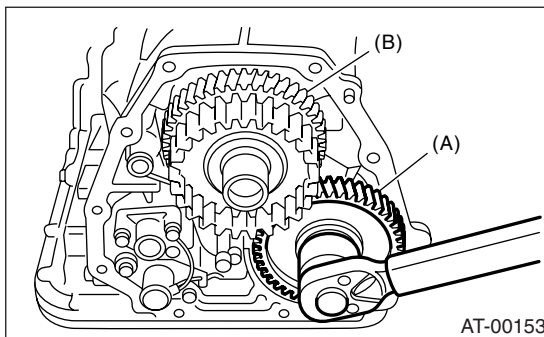

- (A) Reduction driven gear
- (B) Reduction drive gear

- 3) After tightening, stake the lock nut securely.
- 4) Combine the transmission case with the extension case, and install rear vehicle speed sensor. <Ref. to 4AT-68, INSTALLATION, Extension Case.>
- 5) Install the transmission assembly to vehicle. <Ref. to 4AT-40, INSTALLATION, Automatic Transmission Assembly.>

2. VTD MODEL

- 1) Set the select lever to "P" range.

- 2) Using a plastic hammer, install reduction driven gear assembly.
- 3) Using a plastic hammer, install the center differential assembly.
- 4) Install a new self-lock nut and a washer.

Tightening torque:

100 N·m (10.2 kgf·m, 73.8 ft·lb)

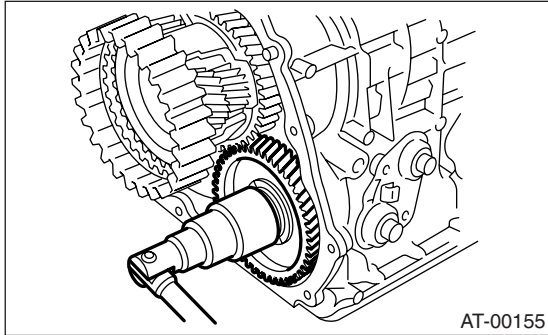

- 5) After tightening, stake the lock nut securely.
- 6) Insert the rear drive shaft assembly. <Ref. to 4AT-79, INSTALLATION, Rear Drive Shaft.>
- 7) Combine the transmission case with the extension case, and install rear vehicle speed sensor. <Ref. to 4AT-68, INSTALLATION, Extension Case.>
- 8) Install the transmission assembly to vehicle. <Ref. to 4AT-40, INSTALLATION, Automatic Transmission Assembly.>

C: DISASSEMBLY

- 1) Remove snap ring from reduction driven gear.

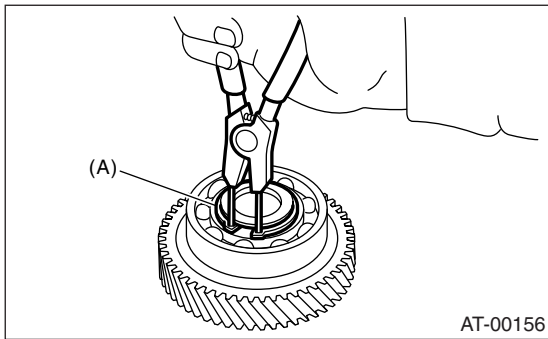

(A) Snap ring

- 2) Using ST, remove ball bearing from reduction driven gear.

ST 498077600 REMOVER

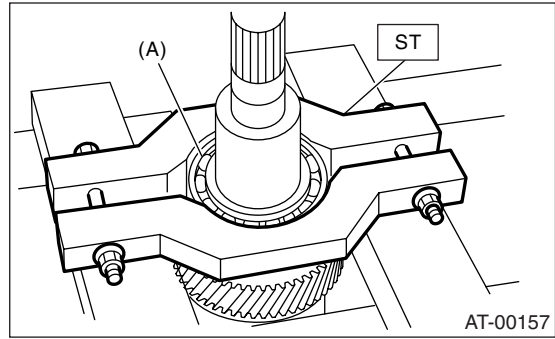

(A) Ball bearing

- 3) Remove snap ring reduction driven gear.

D: ASSEMBLY

- 1) Install snap ring to reduction driven gear.
- 2) Using a press, install a new ball bearing to reduction driven gear.

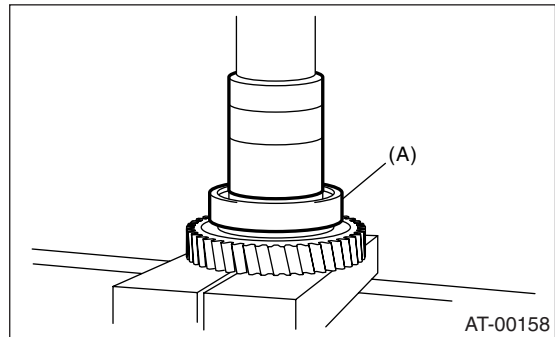

(A) Ball bearing

- 3) Install snap ring to reduction driven gear.

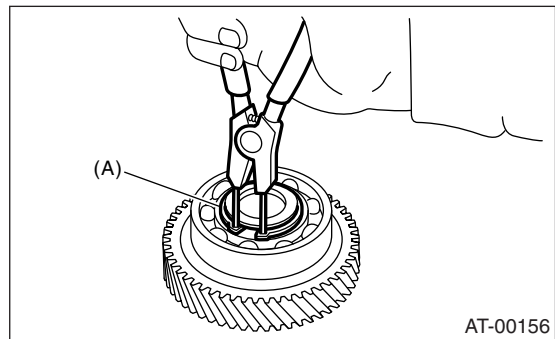

(A) Snap ring

E: INSPECTION

Check ball bearing and gear for dents or damage.

Reduction Drive Gear

AUTOMATIC TRANSMISSION

30.Reduction Drive Gear

A: REMOVAL

1) Remove the transmission assembly from the vehicle. <Ref. to 4AT-38, REMOVAL, Automatic Transmission Assembly.>

2) Remove rear vehicle speed sensor, and separate the transmission case and extension case. <Ref. to 4AT-68, REMOVAL, Extension Case.>

3) Remove the reduction driven gear. <Ref. to 4AT-80, REMOVAL, Reduction Driven Gear.>

4) Using ST, extract the reduction drive gear.

ST1 499737100 PULLER SET

ST2 899524100 PULLER SET

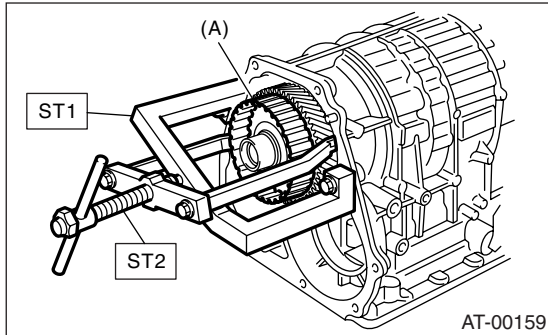

(A) Reduction drive gear

B: INSTALLATION

1) Install the reduction drive gear assembly.

NOTE:

Insert it fully into position until the bearing shoulder bottoms.

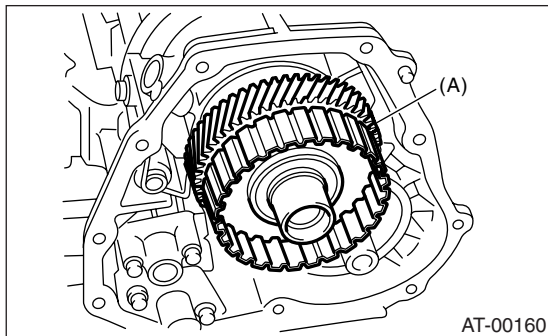

(A) Reduction drive gear

2) Install the reduction driven gear. <Ref. to 4AT-80, INSTALLATION, Reduction Driven Gear.>

3) Combine the transmission case with the extension case, and install rear vehicle speed sensor. <Ref. to 4AT-68, INSTALLATION, Extension Case.>

4) Install the transmission assembly to the vehicle. <Ref. to 4AT-40, INSTALLATION, Automatic Transmission Assembly.>

C: DISASSEMBLY

1) Take out the seal rings.

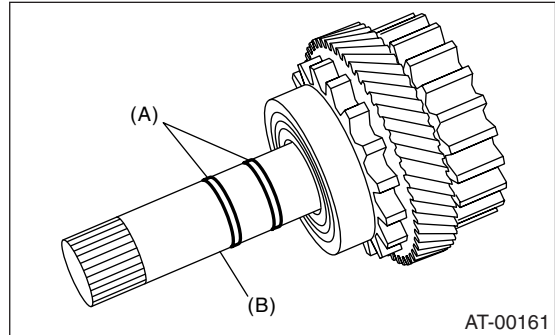

(A) Seal rings

(B) Reduction drive shaft

2) Using ST, remove the ball bearing.

ST 498077600 REMOVER

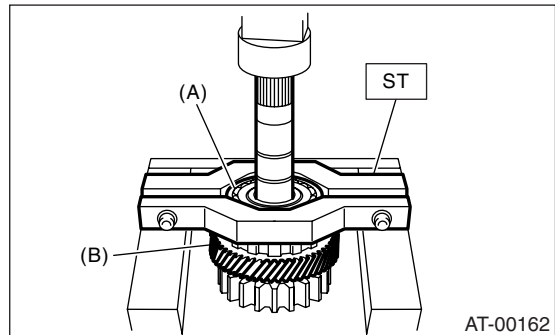

(A) Ball bearing

(B) Reduction drive gear

3) Using a press, remove the reduction drive gear.

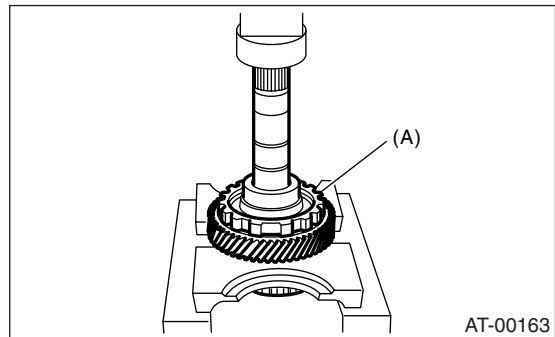

(A) Reduction drive gear

D: ASSEMBLY

1) Press-fit the reduction drive gear to the shaft.

2) Press-fit the a new ball bearing to the reduction drive gear.

3) Apply vaseline to outer surface of seal ring and shaft groove.

4) Apply ATF to new seal rings and attach them.

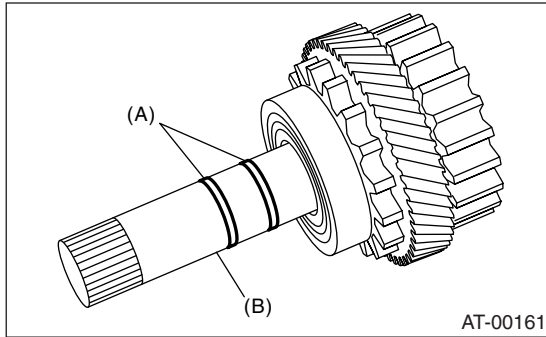

- (A) Seal rings
- (B) Reduction drive shaft

E: INSPECTION

- Rotate bearing by hand, make sure it rotates smoothly.
- Make sure that each component is free of harmful gouges, cuts, or dust.
- Measure the extension end play and adjust it to within specifications. <Ref. to 4AT-75, ADJUSTMENT, Transfer Clutch.>

Center Differential Carrier

AUTOMATIC TRANSMISSION

31.Center Differential Carrier

A: REMOVAL

- 1) Remove the transmission assembly from vehicle. <Ref. to 4AT-38, REMOVAL, Automatic Transmission Assembly.>
- 2) Remove the rear wheel speed sensor, and separate the extension case from the transmission case. <Ref. to 4AT-68, REMOVAL, Extension Case.>
- 3) Pull out the rear drive shaft. <Ref. to 4AT-79, REMOVAL, Rear Drive Shaft.>
- 4) Using the special tools, pull out the center differential carrier assembly.

ST1 499737100 PULLER SET

ST2 899524100 PULLER SET

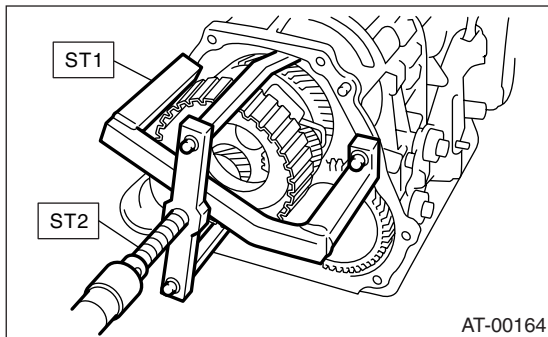

- 5) Pull out the shim(s) from transmission case.

B: INSTALLATION

- 1) Install the center differential assembly with the shim(s).

NOTE:

Insert the center differential assembly and shim(s) completely into the bearing shoulder bottom.

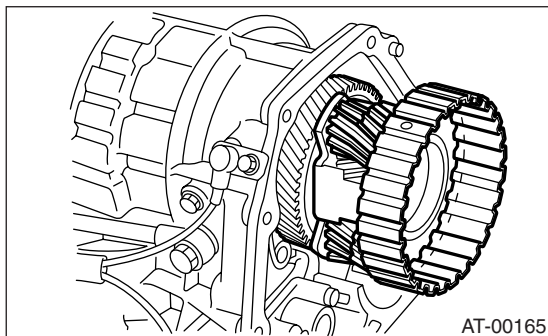

- 2) Insert the rear drive shaft. <Ref. to 4AT-79, INSTALLATION, Rear Drive Shaft.>
- 3) Connect the transmission case and extension case, and install the rear wheel speed sensor. <Ref. to 4AT-68, INSTALLATION, Extension Case.>
- 4) Install the transmission assembly onto vehicle. <Ref. to 4AT-40, INSTALLATION, Automatic Transmission Assembly.>

C: DISASSEMBLY

- 1) Remove the seal rings.

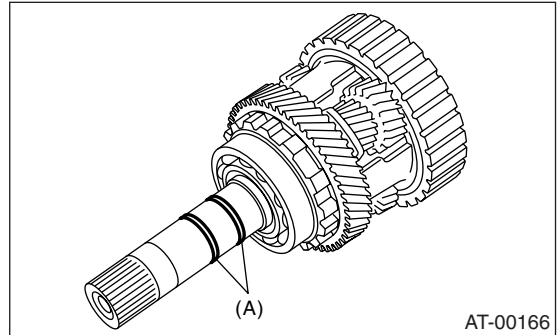

(A) Seal ring

- 2) Using a press and the special tool, remove the ball bearing.

ST 498077600 REMOVER

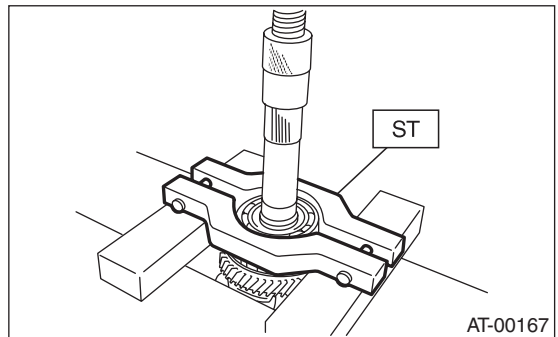

- 3) Remove the snap ring, and pull out the shaft from the center differential assembly.

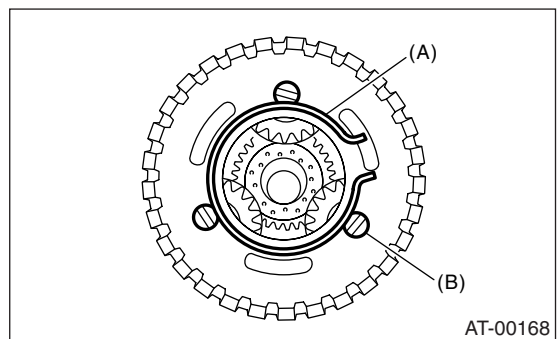

(A) Snap ring

(B) Shaft

- 4) Remove the thrust washers, pinion gears, and washers from the center differential assembly.

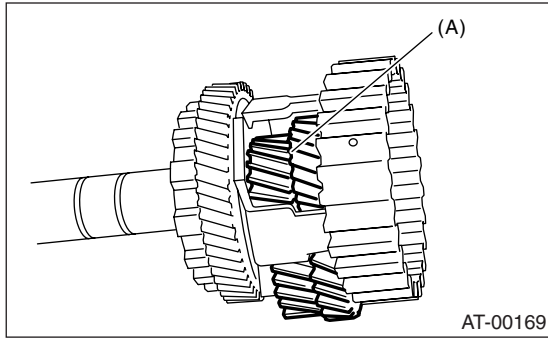

(A) Pinion gear

- 5) Pull out the intermediate shaft and thrust bearing.

D: ASSEMBLY

- 1) Install the thrust washer onto the intermediate shaft.
- 2) Install thrust bearing onto the intermediate shaft.
- 3) Install the pinion gears and washers.
- 4) Insert the shaft into the center differential assembly.
- 5) Install the snap ring.
- 6) Using a press, install a new ball bearing into the center differential assembly.

ST 498077000 REMOVER

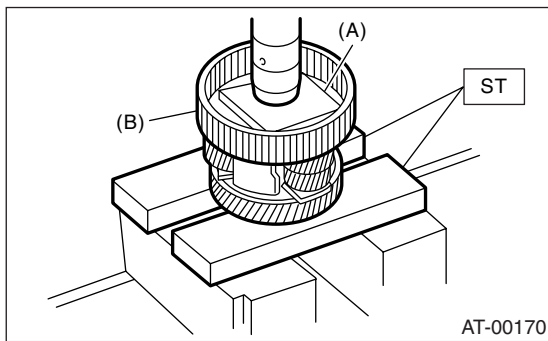

(A) Plate

(B) Center differential carrier

- 7) Apply Vaseline onto the seal ring outer surface and shaft grooves.
- 8) Apply ATF to new seal rings and install them.

E: INSPECTION

- Check all parts for hole, score, or dirt.
- Check the play of the extension end, and if necessary, adjust it. <Ref. to 4AT-76, VTD MODEL, ADJUSTMENT, Transfer Clutch.>

32. Parking Pawl

A: REMOVAL

- 1) Remove the transmission assembly from the vehicle. <Ref. to 4AT-38, REMOVAL, Automatic Transmission Assembly.>
- 2) Remove rear vehicle speed sensor and separate transmission case and extension case sections. <Ref. to 4AT-68, REMOVAL, Extension Case.>
- 3) Remove the reduction drive gear. (MP-T model) <Ref. to 4AT-82, REMOVAL, Reduction Drive Gear.>
- 4) Remove the center differential carrier. (VTD model) <Ref. to 4AT-84, REMOVAL, Center Differential Carrier.>
- 5) Remove the parking pawl, return spring and shaft.

4) Install the rear vehicle speed sensor and extension case. <Ref. to 4AT-68, INSTALLATION, Extension Case.>

5) Install the transmission assembly to the vehicle. <Ref. to 4AT-40, INSTALLATION, Automatic Transmission Assembly.>

C: INSPECTION

Make sure that the tab of the parking pole on the reduction gear is not worn or otherwise damaged.

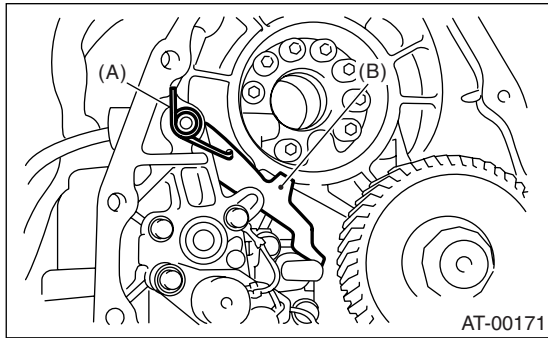

- (A) Return spring
- (B) Parking pawl

B: INSTALLATION

- 1) Install the parking pawl, shaft and return spring.

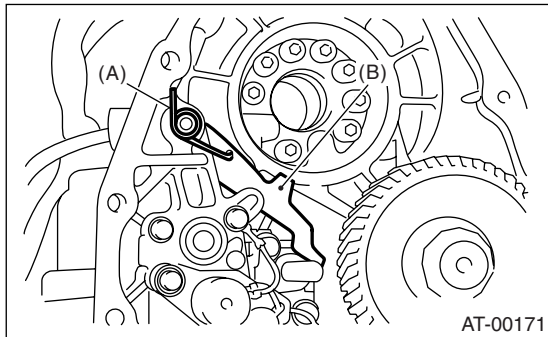

- (A) Return spring
- (B) Parking pawl

2) Install the reduction drive gear. (MP-T model) <Ref. to 4AT-82, INSTALLATION, Reduction Drive Gear.>

3) Install the center differential carrier. (VTD model) <Ref. to 4AT-84, INSTALLATION, Center Differential Carrier.>

33. Converter Case

A: REMOVAL

- 1) Remove the transmission assembly from the vehicle. <Ref. to 4AT-38, REMOVAL, Automatic Transmission Assembly.>
- 2) Extract the torque converter clutch assembly. <Ref. to 4AT-67, REMOVAL, Torque Converter Clutch Assembly.>
- 3) Remove the input shaft.

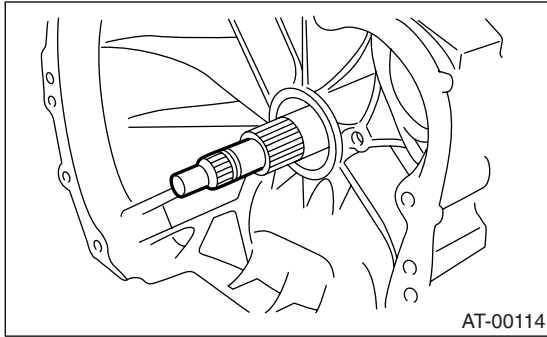

- 4) Lift-up lever behind the connector and disconnect it from stay.
- 5) Disconnect inhibitor switch connector from stay.

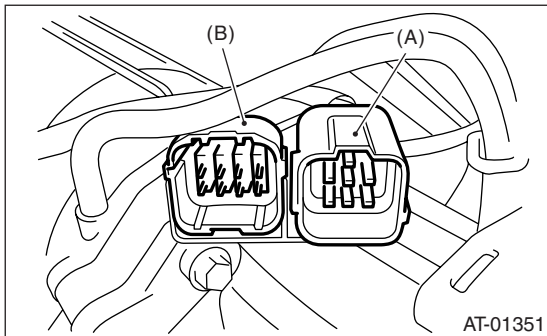

- (A) Transmission harness
(B) Inhibitor switch harness

- 6) Remove the oil charge pipe. <Ref. to 4AT-66, REMOVAL, Oil Charge Pipe.>
- 7) Remove the oil cooler inlet and outlet pipes. <Ref. to 4AT-63, REMOVAL, ATF Cooler Pipe and Hose.>
- 8) Lightly tapping the converter case with plastic hammer, separate the transmission case and converter case.

NOTE:

- Be careful not to damage the oil seal and bushing inside the converter case by the oil pump cover.

- Be careful not to lose the rubber seal.

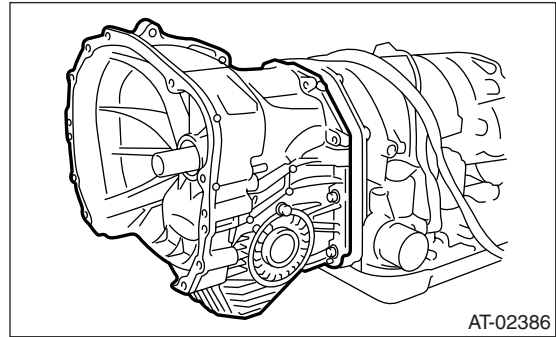

- 9) Remove the seal pipe if it is attached. (Reusing is not allowed.)

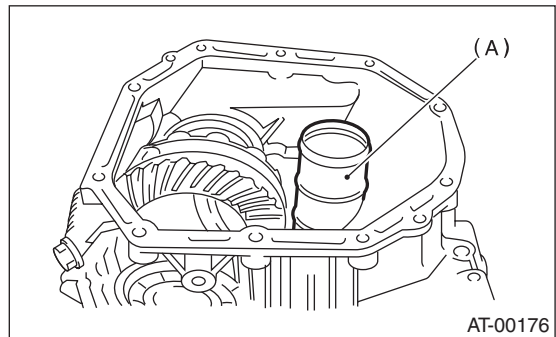

- (A) Seal pipe

- 10) Remove the differential assembly. <Ref. to 4AT-99, REMOVAL, Front Differential Assembly.>
- 11) Remove the oil seal from converter case.

B: INSTALLATION

- 1) Check the appearance of each component and clean.
- 2) Force-fit the oil seal to the converter case with ST.
ST 398437700 DRIFT

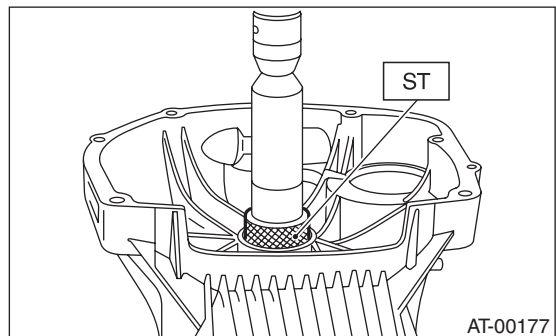

- 3) Install the differential assembly to the case. <Ref. to 4AT-99, INSTALLATION, Front Differential Assembly.>
- 4) Install the left and right side retainers. <Ref. to 4AT-103, ADJUSTMENT, Front Differential Assembly.>

Converter Case

AUTOMATIC TRANSMISSION

5) Install the new seal pipe to the converter case.

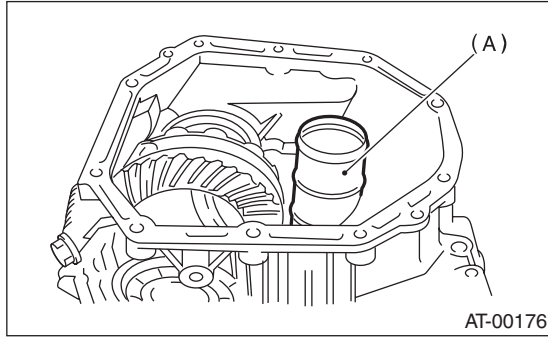

(A) Seal pipe

6) Install the rubber seal to the converter case.

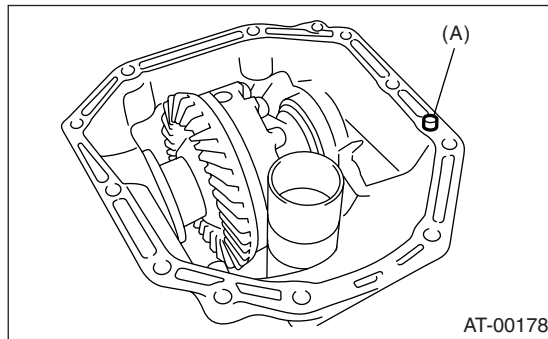

(A) Rubber seal

7) Apply proper amount of liquid gasket to the entire converter case mating surface.

Liquid gasket:

THREE BOND 1215 (Part No. 004403007)

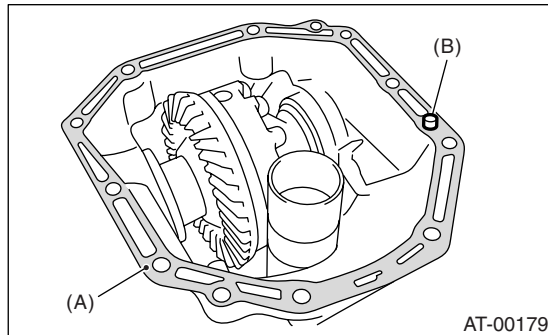

(A) THREE BOND 1215

(B) Rubber seal

8) Install the converter case assembly without damaging bushing and oil seal and secure with six bolts and four nuts.

Tightening torque:

41 N·m (4.2 kgf-m, 30.2 ft-lb)

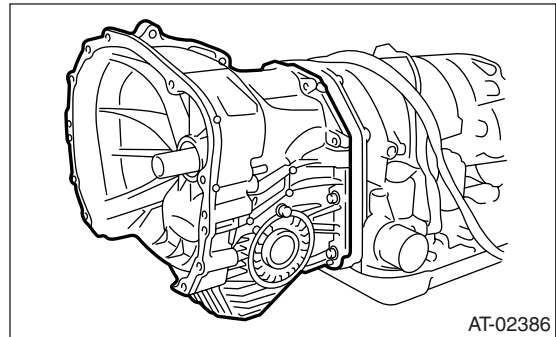

9) Insert inhibitor switch and transmission connector into stay.

10) Install air breather hose. <Ref. to 4AT-65, INSTALLATION, Air Breather Hose.>

11) Install the oil cooler pipes. <Ref. to 4AT-63, INSTALLATION, ATF Cooler Pipe and Hose.>

12) Install the oil charge pipe with O-ring. <Ref. to 4AT-66, INSTALLATION, Oil Charge Pipe.>

13) Insert the input shaft while turning lightly by hand and verify the protrusion amount.

Normal protrusion A:

50 — 55 mm (1.97 — 2.17 in)

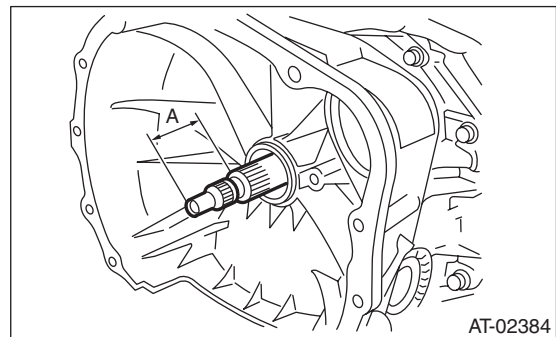

14) Install the torque converter clutch assembly. <Ref. to 4AT-67, INSTALLATION, Torque Converter Clutch Assembly.>

15) Install the transmission assembly to the vehicle. <Ref. to 4AT-40, INSTALLATION, Automatic Transmission Assembly.>

C: INSPECTION

Measure the backlash and adjust to within specifications. <Ref. to 4AT-97, ADJUSTMENT, Drive Pinion Shaft Assembly.>

34. Oil Pump Housing

A: REMOVAL

- 1) Remove the transmission assembly from the vehicle. <Ref. to 4AT-38, REMOVAL, Automatic Transmission Assembly.>
- 2) Extract the torque converter clutch assembly. <Ref. to 4AT-67, REMOVAL, Torque Converter Clutch Assembly.>
- 3) Remove the input shaft.

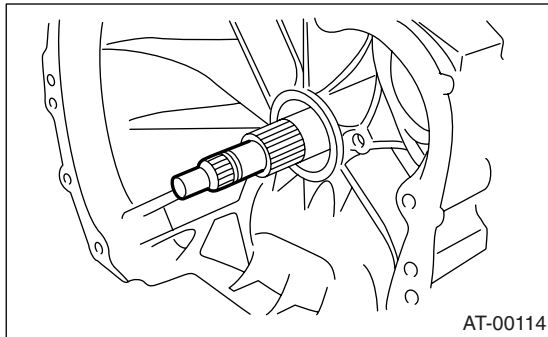

- 4) Lift-up lever behind the transmission harness connector and disconnect it from stay.
- 5) Disconnect inhibitor switch connector from stay.
- 6) Remove the oil charge pipe. <Ref. to 4AT-66, REMOVAL, Oil Charge Pipe.>
- 7) Remove the ATF oil cooler inlet and outlet pipes. <Ref. to 4AT-63, REMOVAL, ATF Cooler Pipe and Hose.>
- 8) Separation of converter case and transmission case sections <Ref. to 4AT-87, REMOVAL, Converter Case.>
- 9) Separate transmission case and extension case sections. <Ref. to 4AT-68, REMOVAL, Extension Case.>
- 10) Remove the reduction drive gear. (MP-T model) <Ref. to 4AT-82, REMOVAL, Reduction Drive Gear.>
- 11) Remove the center differential carrier. (VTD model) <Ref. to 4AT-84, REMOVAL, Center Differential Carrier.>
- 12) Remove the reduction driven gear. <Ref. to 4AT-80, REMOVAL, Reduction Driven Gear.>
- 13) Loosen the oil pump housing mounting bolts.

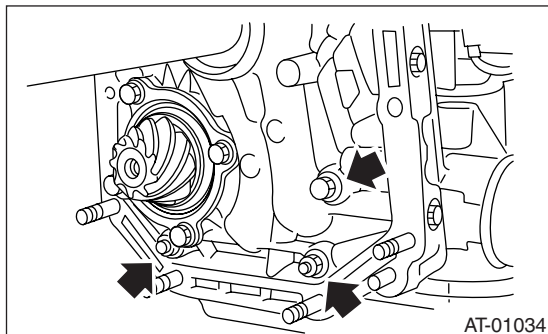

- 14) Place two wooden blocks on the workbench, and stand the transmission case with its rear end facing down.

NOTE:

- Be careful not to scratch the rear mating surface of the transmission case.
- Note that the parking rod and drive pinion protrude from the mating surface.

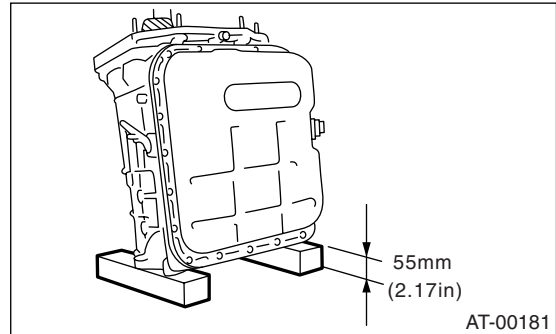

- 15) Remove the oil pump housing and adjusting thrust washer.

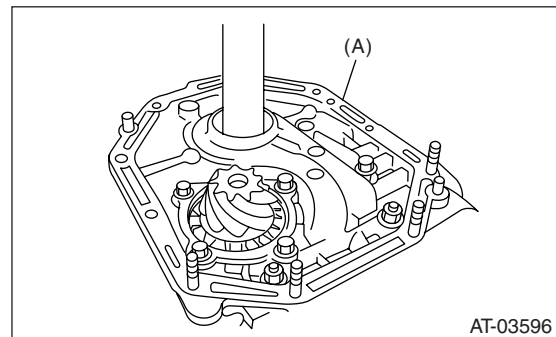

(A) Oil pump housing

B: INSTALLATION

- 1) Secure the oil pump housing with two nuts and a bolt.

Tightening torque:

42 N·m (4.3 kgf-m, 31 ft-lb)

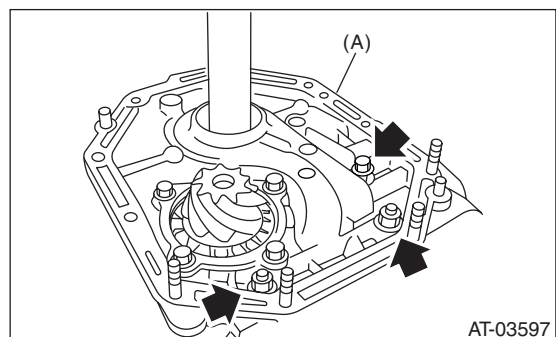

(A) Oil pump housing

Oil Pump Housing

AUTOMATIC TRANSMISSION

- 2) Install the converter case assembly to the transmission case assembly. <Ref. to 4AT-67, INSTALLATION, Torque Converter Clutch Assembly.>
- 3) Install reduction driven gear. <Ref. to 4AT-80, INSTALLATION, Reduction Driven Gear.>
- 4) Install the reduction drive gear. (MP-T model) <Ref. to 4AT-82, INSTALLATION, Reduction Drive Gear.>
- 5) Install the center differential carrier. (VTD model) <Ref. to 4AT-84, INSTALLATION, Center Differential Carrier.>
- 6) Combine the extension case with the transmission case, and install rear vehicle speed sensor. <Ref. to 4AT-68, INSTALLATION, Extension Case.>
- 7) Insert inhibitor switch and transmission connector into stay.

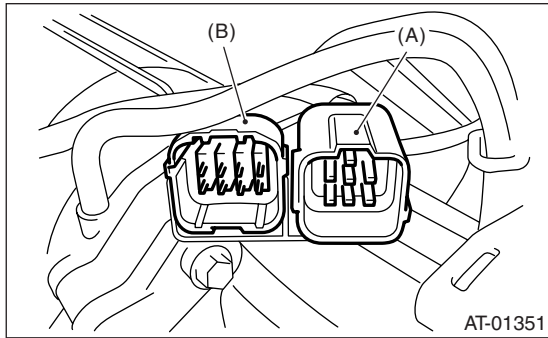

- (A) Transmission harness
- (B) Inhibitor switch harness

- 8) Install the ATF cooler pipe. <Ref. to 4AT-63, INSTALLATION, ATF Cooler Pipe and Hose.>
- 9) Install the oil charge pipe with O-ring. <Ref. to 4AT-66, INSTALLATION, Oil Charge Pipe.>
- 10) Insert the input shaft while rotating it lightly by hand, and then check the protrusion amount.

Normal protrusion amount A:
50 — 55 mm (1.97 — 2.17 in)

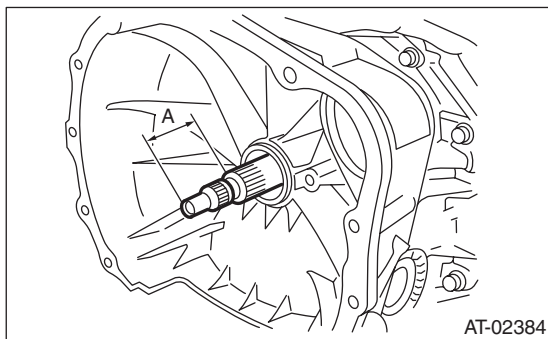

- 11) Install the torque converter clutch assembly. <Ref. to 4AT-67, INSTALLATION, Torque Converter Clutch Assembly.>

- 12) Install the transmission assembly to the vehicle. <Ref. to 4AT-40, INSTALLATION, Automatic Transmission Assembly.>

C: DISASSEMBLY

1. OIL PUMP COVER

- 1) Remove four seal rings.

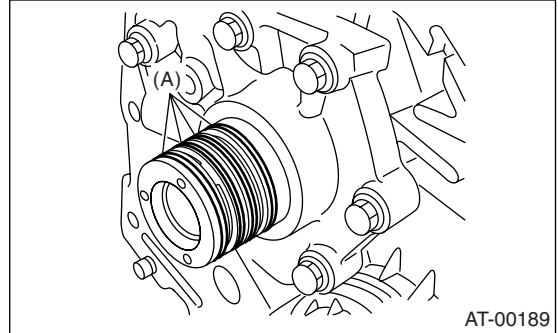

- (A) Seal rings

- 2) Lightly tap the end of the stator shaft to remove the cover.

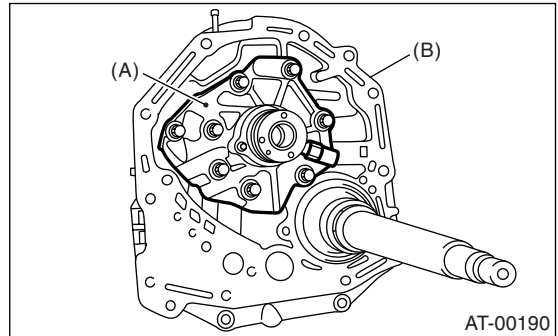

- (A) Oil pump cover
- (B) Oil pump housing

- 3) Remove the inner and outer rotor.

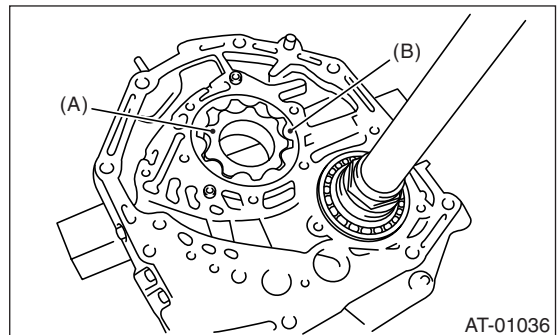

- (A) Inner rotor
- (B) Outer rotor

2. OIL SEAL RETAINER

1) Remove the oil seal retainer.

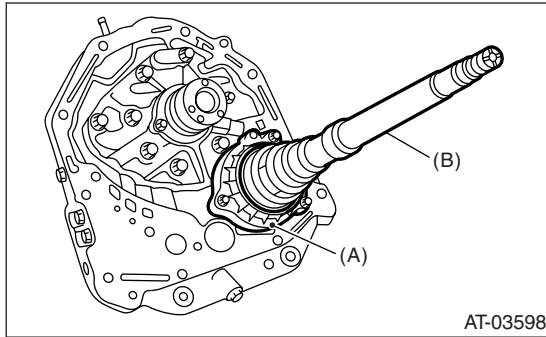

- (A) Oil seal retainer
- (B) Drive pinion shaft

2) Remove the O-ring.

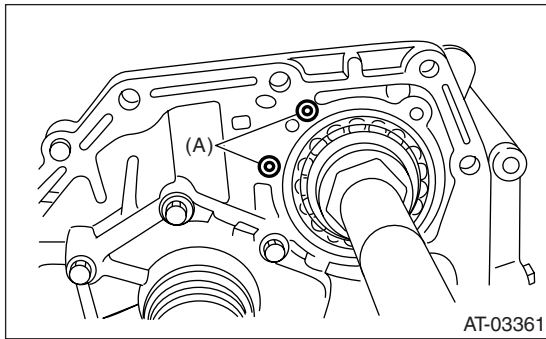

- (A) O-ring

3) Remove the oil seal from oil seal retainer.

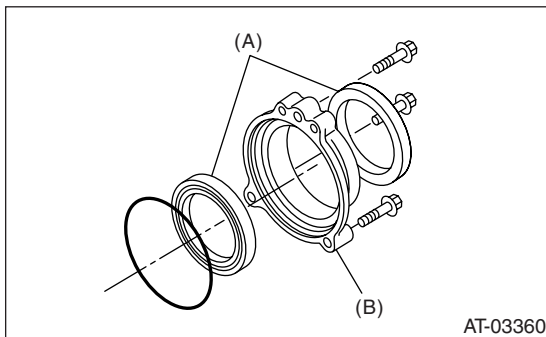

- (A) Oil seal
- (B) Oil seal retainer

D: ASSEMBLY

1. OIL PUMP COVER

1) Install oil pump rotor assembly to oil pump housing.

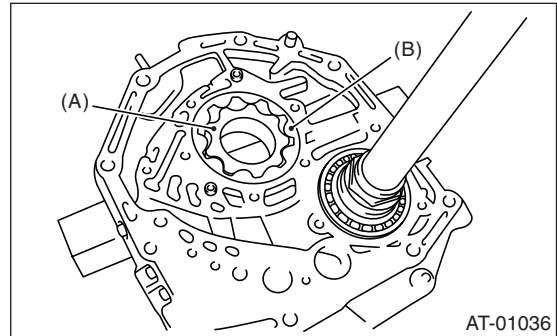

- (A) Inner rotor
- (B) Outer rotor

2) Align both pivots with the pivot holes of the cover, and install the oil pump cover being careful not to apply undue force to the pivots.

Tightening torque:
25 N·m (2.5 kgf·m, 18.4 ft·lb)

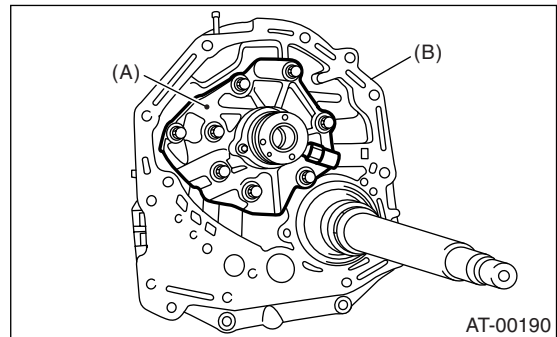

- (A) Oil pump cover
- (B) Oil pump housing

3) After assembling, turn the oil pump shaft to check for smooth rotation of the rotor.

4) Install the oil seal retainer and new seal rings. After adjusting the drive pinion backlash and tooth

Oil Pump Housing

AUTOMATIC TRANSMISSION

contact. <Ref. to 4AT-93, ADJUSTMENT, Oil Pump Housing.>

Tightening torque:
7 N·m (0.7 kgf-m, 5.1 ft-lb)

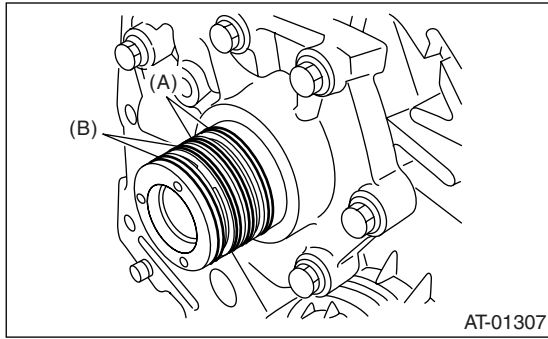

- (A) Seal rings (Black)
- (B) Seal rings (Brown)

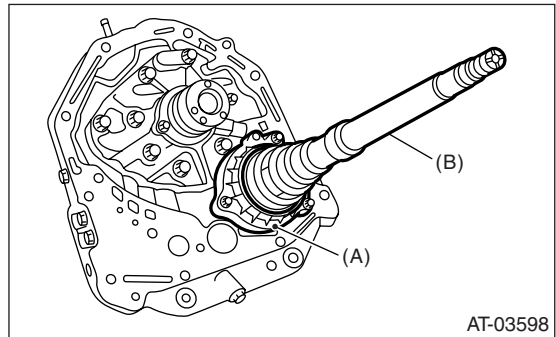

- (A) Oil seal retainer
- (B) Drive pinion shaft

2. OIL SEAL RETAINER

1) Install two new oil seals to the oil seal retainer in proper position using ST.
ST 499247300 INSTALLER

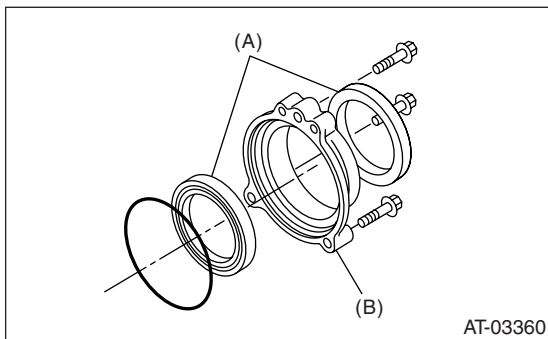

- (A) Oil seal
- (B) Oil seal retainer

2) Install a new O-ring to the oil seal retainer using vaseline. Install the seal to oil pump housing bore.

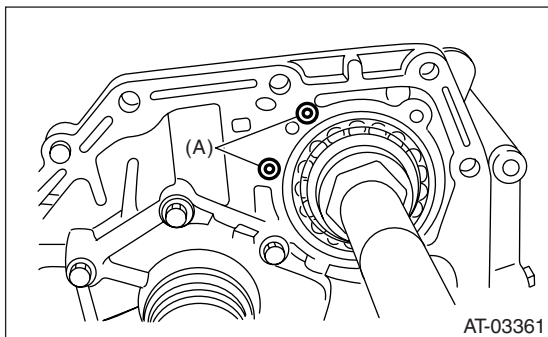

- (A) O-ring

3) Install the oil seal and secure it using three bolts being careful not to damage oil seal lip.

E: INSPECTION

- 1) Check seal ring and O-ring oil seal for breaks or damage.
- 2) Check other parts for dents or abnormalities.
- 3) Selection of oil pump rotor assembly

(1) Tip clearance

Install inner rotor and outer rotor to oil pump. With rotor gears facing each other, measure crest-to-crest clearance.

Tip clearance:

0.02 — 0.15 mm (0.0008 — 0.0059 in)

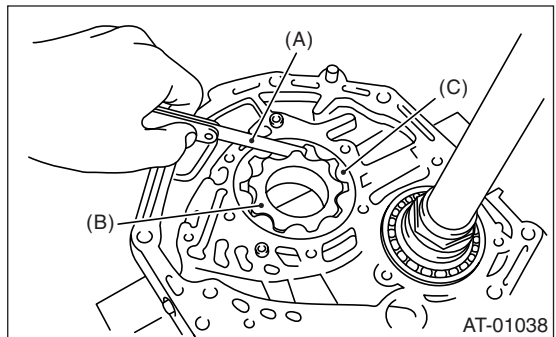

- (A) Thickness gauge
- (B) Inner rotor
- (C) Outer rotor

(2) Side clearance

Set a depth gauge to oil pump housing, then measure oil pump housing-to-rotor clearances.

Side clearance:

0.02 — 0.04 mm (0.0008 — 0.0016 in)

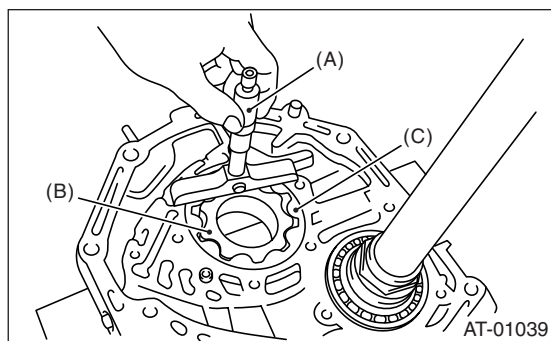

- (A) Depth gauge
- (B) Inner rotor
- (C) Outer rotor

(3) If depth and/or side clearances are outside specifications, replace oil pump rotor assembly.

Oil pump rotor assembly	
Part No.	Thickness mm (in)
15008AA060	11.37 — 11.38 (0.4476 — 0.4480)
15008AA070	11.38 — 11.39 (0.4480 — 0.4484)
15008AA080	11.39 — 11.40 (0.4484 — 0.4488)

Measure the total end play and adjust to within specifications. <Ref. to 4AT-93, ADJUSTMENT, Oil Pump Housing.>

F: ADJUSTMENT

1) Using the ST, measure the distance from the end surface of ST to the recessed portion “L” of the high clutch drum.

ST 398643600 GAUGE

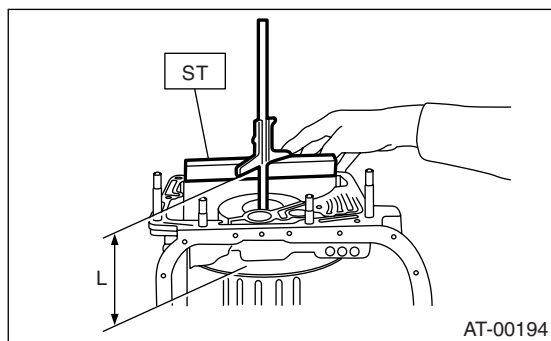

2) Using the ST, measure the distance from the oil pump housing mating surface to the end surface of ST.

ST 398643600 GAUGE

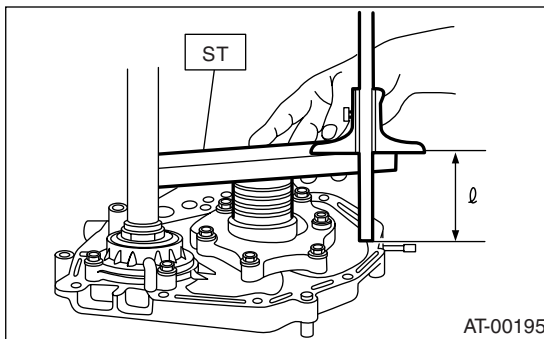

3) Calculation of total end play

Select suitable bearing race from among those listed in this table so that clearance C is in the 0.25 to 0.55 mm (0.0098 to 0.0217 in) range.

$$C = (L + G) - l$$

C	Clearance between concave portion of high clutch and end of clutch drum support
L	Length from case mating surface to the end surface of ST
G	Gasket thickness [0.28 mm (0.0110 in)]
l	Height from housing mating surface to the end surface of ST

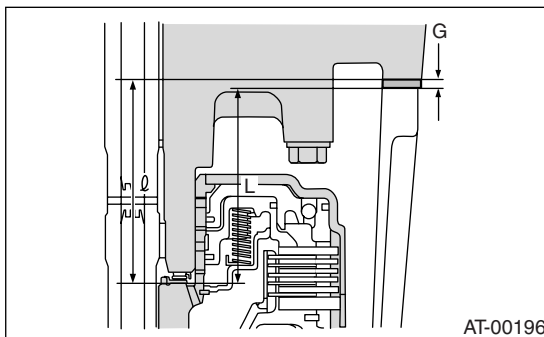

Thrust needle bearing	
Part No.	Thickness mm (in)
806528050	4.1 (0.161)
806528060	4.3 (0.169)
806528070	4.5 (0.177)
806528080	4.7 (0.185)
806528090	4.9 (0.193)
806528100	5.1 (0.201)

4) After completing end play adjustment, insert the bearing race in the recess of the high clutch. Attach the thrust needle bearing to the oil pump cover with vaseline.

5) After correctly installing the new gasket to the case mating surface, carefully install the oil pump housing assembly. Be careful to avoid hitting the drive pinion against the inside of the case.

6) Install both parts with dowel pins aligned. Make sure no clearance exists at the mating surface.

Drive Pinion Shaft Assembly

AUTOMATIC TRANSMISSION

35. Drive Pinion Shaft Assembly

A: REMOVAL

- 1) Remove the transmission assembly from vehicle. <Ref. to 4AT-38, REMOVAL, Automatic Transmission Assembly.>
- 2) Extract the torque converter clutch assembly. <Ref. to 4AT-67, REMOVAL, Torque Converter Clutch Assembly.>
- 3) Remove the input shaft.

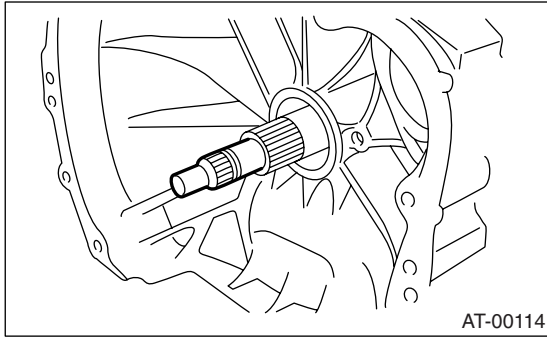

- 4) Lift-up lever behind the transmission harness connector and disconnect it from stay.
- 5) Disconnect inhibitor switch connector from stay.
- 6) Disconnect the air breather hose. <Ref. to 4AT-65, REMOVAL, Air Breather Hose.>
- 7) Remove the oil charge pipe. <Ref. to 4AT-66, REMOVAL, Oil Charge Pipe.>
- 8) Remove the oil cooler inlet and outlet pipes. <Ref. to 4AT-63, REMOVAL, ATF Cooler Pipe and Hose.>
- 9) Separation of converter case and transmission case sections <Ref. to 4AT-87, REMOVAL, Converter Case.>
- 10) Separate transmission case and extension case sections. <Ref. to 4AT-68, REMOVAL, Extension Case.>
- 11) Remove the reduction drive gear. (MP-T model) <Ref. to 4AT-82, REMOVAL, Reduction Drive Gear.>
- 12) Remove the center differential carrier. (VTD model) <Ref. to 4AT-84, REMOVAL, Center Differential Carrier.>
- 13) Remove the reduction driven gear. <Ref. to 4AT-80, REMOVAL, Reduction Driven Gear.>

- 14) Remove the drive pinion shaft mounting bolt and remove the drive shaft assembly from oil pump housing.

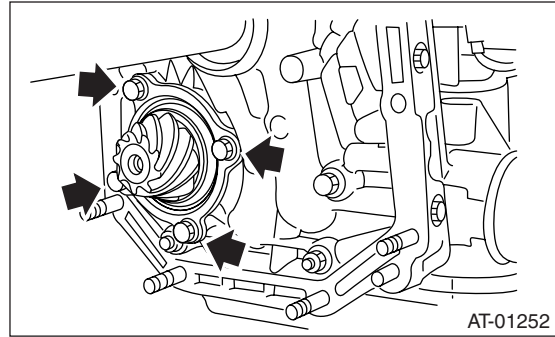

B: INSTALLATION

- 1) Assemble the drive pinion assembly to the oil pump housing.

NOTE:

- Pay attention not to bend the shim.
- Pay attention not to press the pinion into housing bore.

Tightening torque:

40 N·m (4.1 kgf-m, 29.5 ft-lb)

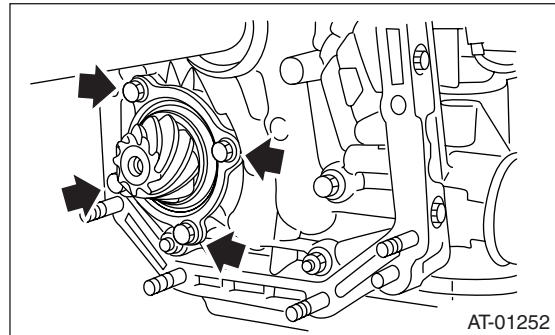

- 2) Combine the torque converter case with the transmission case. <Ref. to 4AT-87, INSTALLATION, Converter Case.>
- 3) Install the reduction driven gear. <Ref. to 4AT-80, INSTALLATION, Reduction Driven Gear.>
- 4) Install the reduction drive gear. (MP-T model) <Ref. to 4AT-82, INSTALLATION, Reduction Drive Gear.>
- 5) Install the center differential carrier. (VTD model) <Ref. to 4AT-84, INSTALLATION, Center Differential Carrier.>
- 6) Join transmission case and extension case. Install rear vehicle speed sensor. <Ref. to 4AT-68, INSTALLATION, Extension Case.>
- 7) Insert inhibitor switch and transmission connector into stay.
- 8) Install the oil cooler inlet and outlet pipes. <Ref. to 4AT-63, INSTALLATION, ATF Cooler Pipe and Hose.>
- 9) Install the oil charge pipe with O-ring.

Drive Pinion Shaft Assembly

AUTOMATIC TRANSMISSION

10) Insert the input shaft while rotating it lightly by hand, and then check the protrusion amount.

Normal protrusion amount A:
50 — 55 mm (1.97 — 2.17 in)

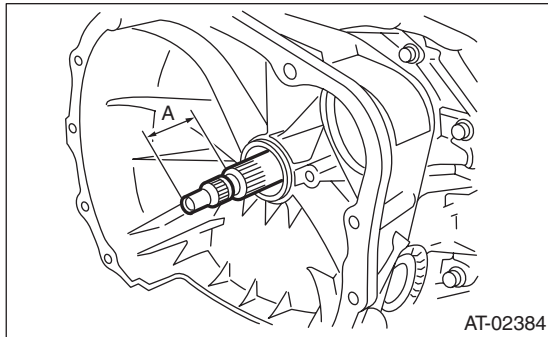

11) Install the torque converter clutch assembly.
<Ref. to 4AT-67, INSTALLATION, Torque Converter Clutch Assembly.>

12) Install the transmission assembly to vehicle.
<Ref. to 4AT-40, INSTALLATION, Automatic Transmission Assembly.>

C: DISASSEMBLY

1) Straighten the staked portion of the lock nut, and remove the lock nut while locking the rear spline portion of the shaft with ST1 and ST2. Then pull off the drive pinion collar.

ST1 498937110 HOLDER
ST2 499787700 WRENCH
ST3 499787500 ADAPTER

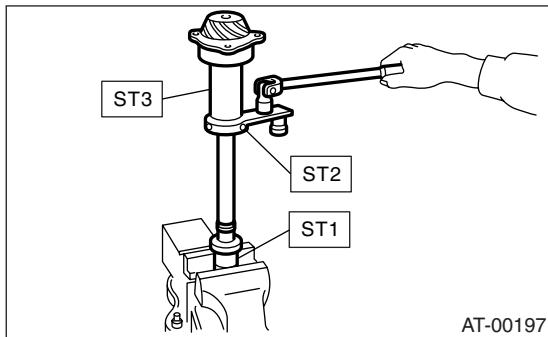

2) Remove the O-ring.

3) Using a press, separate the rear roller bearing and outer race from the shaft.

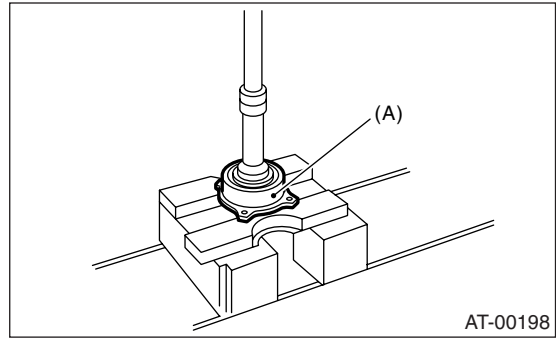

(A) Outer race

4) Using a press and ST, separate the front roller bearing from the shaft.

ST 498517000 REPLACER

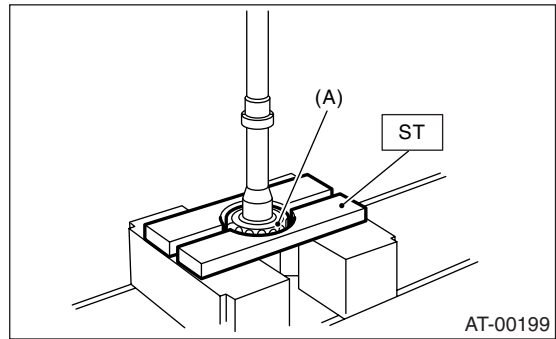

(A) Front roller bearing

D: ASSEMBLY

1) Measure dimension "A" of the drive pinion shaft.

ST 398643600 GAUGE

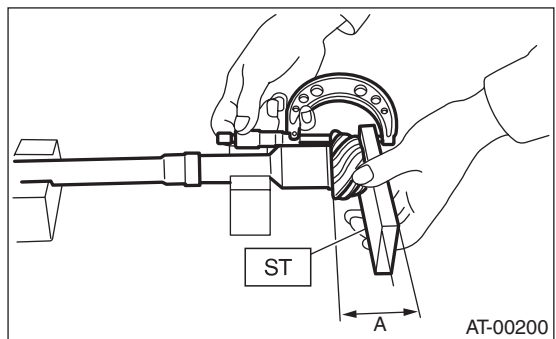

2) Using a press, force-fit a new roller bearing in position.

Drive Pinion Shaft Assembly

AUTOMATIC TRANSMISSION

NOTE:

If too much pressure is applied, the roller bearing will not turn easily.

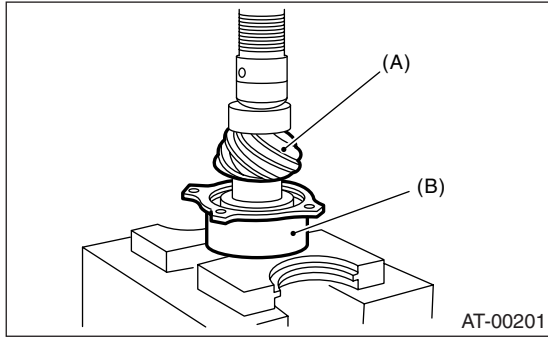

- (A) Drive pinion shaft
- (B) Roller bearing

3) After fitting a new O-ring to the shaft, attach the drive pinion collar to the shaft.

4) Install the lock washer to drive pinion shaft in proper direction.

5) Tighten a new lock nut with ST1, ST2 and ST3. Calculate lock washer and lock nut specifications using the following formula.

$$T2 = L2 / (L1 + L2) \times T1$$

T1: 116 N·m (11.8 kgf·m, 85.3 ft·lb)

[Required torque setting]

T2: Tightening torque

L1: ST2 length 0.072 m (2.83 in)

L2: Torque wrench length

Example:

Torque wrench length m (in)	Tightening torque N·m (kgf·m, ft·lb)
0.4 (15.75)	98 (10.0, 72)
0.45 (17.72)	100 (10.2, 73.8)
0.5 (19.69)	101 (10.3, 74.5)
0.55 (21.65)	102 (10.4, 75)

- ST1 498937110 HOLDER
- ST2 499787700 WRENCH
- ST3 499787500 ADAPTER

NOTE:

Install ST2 to torque wrench as straight as possible.

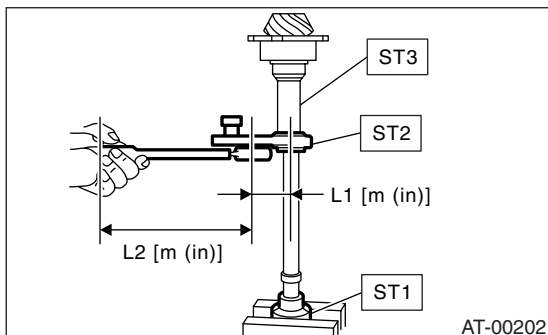

6) Measure the starting torque of the bearing. Make sure the starting torque is within the specified range. If out of the allowable range, replace the roller bearing.

Starting torque:

MP-T model

7.6 — 38.1 N (0.776 — 3.88 kgf, 1.7 — 8.6 lbf)

VTD model

6.8 — 47.5 N (0.69 — 4.84 kgf, 1.52 — 10.67 lbf)

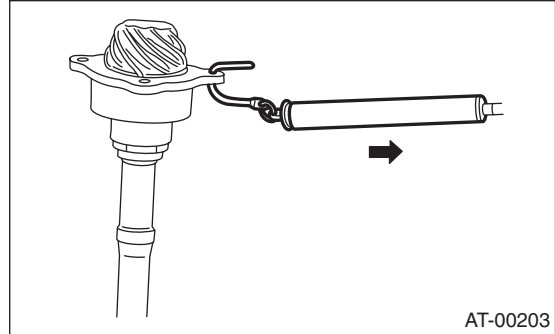

7) Stake the lock nut securely at two places.

8) Measure dimension "B" of the drive pinion shaft.

ST 398643600 GAUGE

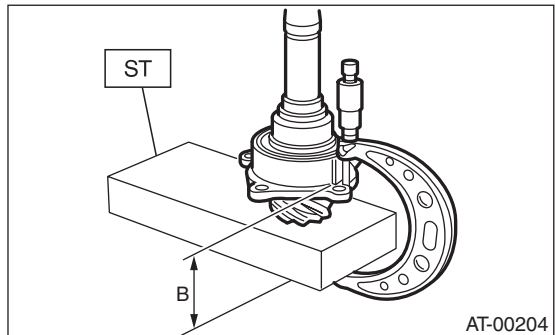

9) The thickness "t" (mm) of the drive pinion shim.

$$t = 6.5 \pm 0.0625 - (B - A)$$

10) Select three or less shims from following table.

Available drive pinion shims	
Part No.	Thickness mm (in)
31451AA050	0.150 (0.0059)
31451AA060	0.175 (0.0069)
31451AA070	0.200 (0.0079)
31451AA080	0.225 (0.0089)
31451AA090	0.250 (0.0098)
31451AA100	0.275 (0.0108)

E: INSPECTION

- Make sure that all component parts are free of harmful cuts, gouges, and other faults.
- Adjust the teeth alignment. <Ref. to 4AT-97, ADJUSTMENT, Drive Pinion Shaft Assembly.>

F: ADJUSTMENT

- 1) Thoroughly remove the liquid gasket from the case mating surface beforehand.
- 2) Install the oil pump housing assembly to the converter case, and secure evenly by tightening four bolts.

NOTE:

Use an old gasket or an aluminum washer so as not to damage the mating surface of the housing.

Tightening torque:

41 N·m (4.2 kgf-m, 30.2 ft-lb)

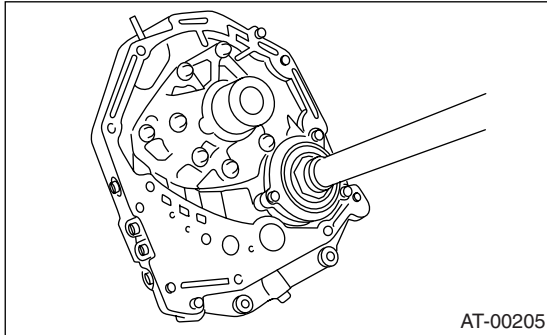

- 3) Rotate the drive pinion several times with ST1 and ST2.

ST1 498937110 HOLDER
ST2 499787700 WRENCH

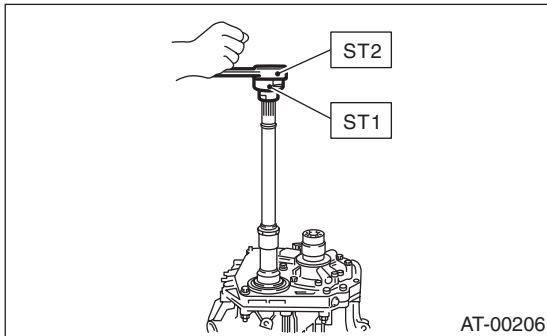

- 4) Adjust the backlash between drive pinion and hypoid driven gear. <Ref. to 4AT-103, ADJUSTMENT, Front Differential Assembly.>

5) Apply red lead evenly to the surfaces of three or four teeth of the hypoid driven gear. Rotate the drive pinion in the forward and reverse directions several times. Then remove the oil pump housing, and check the tooth contact pattern.

If tooth contact is improper, readjust the backlash or shim thickness. <Ref. to 4AT-103, ADJUSTMENT, Front Differential Assembly.>

- Tooth contact

Checking item: Tooth contact pattern is slightly shifted toward to toe side under no-load rotation. [When loaded, contact pattern moves toward heel.]

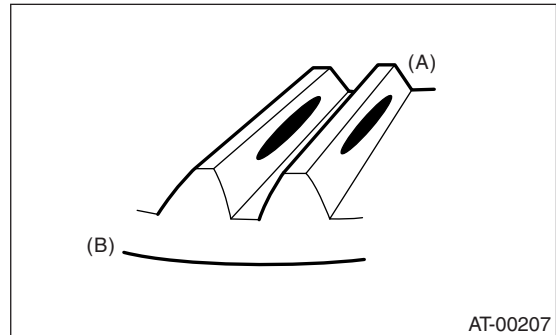

(A) Toe side

(B) Heel side

- Face contact

Checking item: Backlash is too large.

Contact pattern

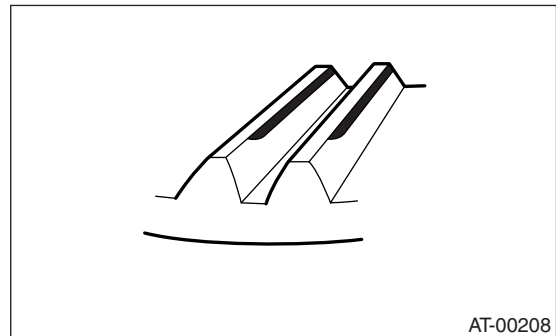

Corrective action: Increase thickness of drive pinion height adjusting washer in order to bring drive pinion close to hypoid driven gear.

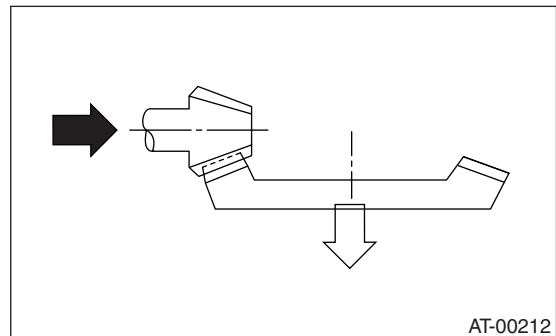

Drive Pinion Shaft Assembly

AUTOMATIC TRANSMISSION

- Flank contact

Checking item: Backlash is too small.

Contact pattern

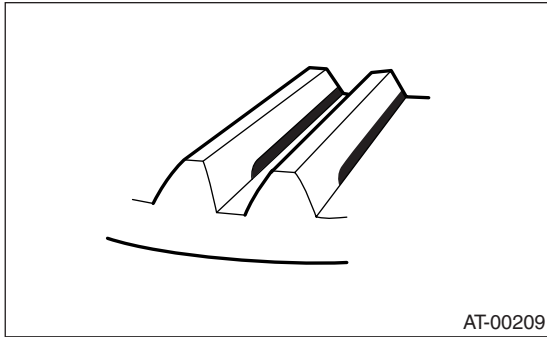

Corrective action: Reduce thickness of drive pinion height adjusting washer in order to move drive pinion away from hypoid driven gear.

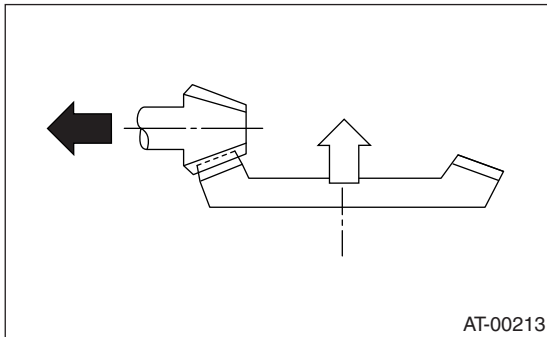

- Toe contact (Inside end contact)

Checking item: Contact area is small.

Contact pattern

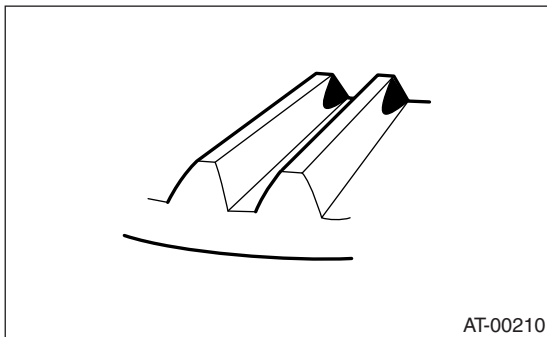

Corrective action: Decrease thickness of drive pinion height adjusting washer in order to move drive pinion away from hypoid driven gear.

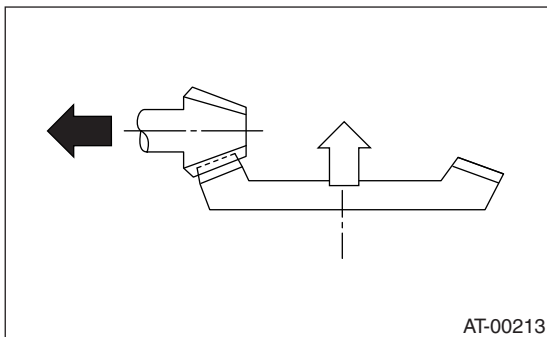

- Heel contact (Outside end contact)

Checking item: Contact area is small.

Contact pattern

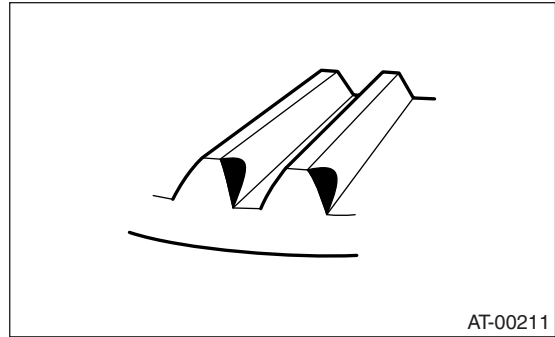

Corrective action: Increase thickness of drive pinion height adjusting washer in order to move drive pinion close to hypoid driven gear.

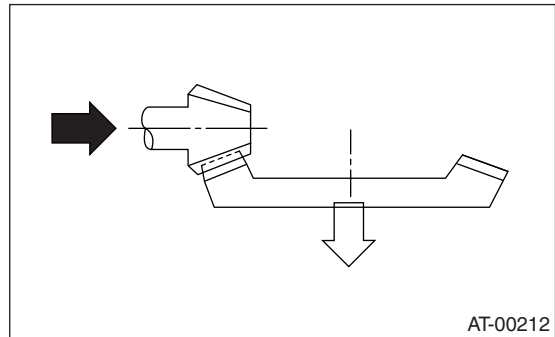

6) If tooth contact is correct, mark the retainer position and loosen it. After fitting a new O-ring and oil seal, screw in the retainer to the marked position. Then tighten the lock plate to the specified torque.

Tightening torque:

25 N·m (2.5 kgf-m, 18.4 ft-lb)

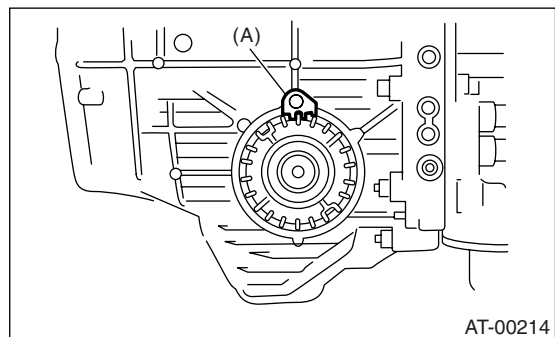

(A) Lock plate

36. Front Differential Assembly

A: REMOVAL

- 1) Remove the transmission assembly from the vehicle. <Ref. to 4AT-38, REMOVAL, Automatic Transmission Assembly.>
- 2) Extract the torque converter clutch assembly. <Ref. to 4AT-67, REMOVAL, Torque Converter Clutch Assembly.>
- 3) Remove the input shaft.

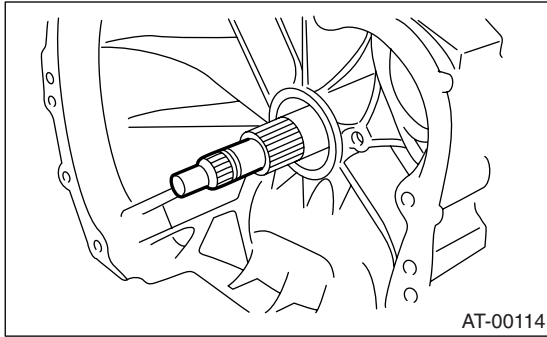

- 4) Lift-up lever behind the transmission harness connector and disconnect it from stay.
- 5) Disconnect inhibitor switch from stay.
- 6) Remove the oil charge pipe. <Ref. to 4AT-66, REMOVAL, Oil Charge Pipe.>
- 7) Remove the oil cooler inlet and outlet pipes. <Ref. to 4AT-63, REMOVAL, ATF Cooler Pipe and Hose.>
- 8) Separation of converter case and transmission case. <Ref. to 4AT-87, REMOVAL, Converter Case.>
- 9) Remove the seal pipe.
- 10) Remove the differential side retainer with ST.

NOTE:

Hold the differential case assembly by hand to avoid damaging retainer mounting hole of the converter case.

ST 499787000 WRENCH ASSY

- 11) Remove the differential assembly without damaging installation part of retainer.

B: INSTALLATION

- 1) Install the differential assembly to the torque converter clutch case.

CAUTION:

Do not damage the inside of the torque converter clutch case (particularly, the differential side retainer contact surface).

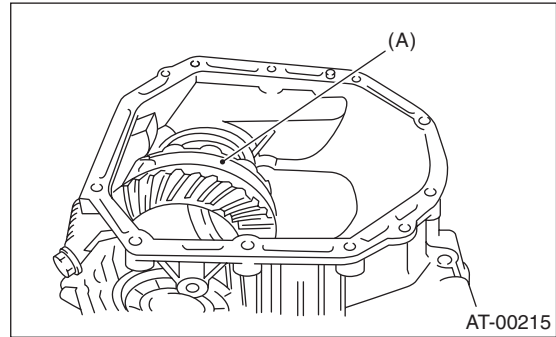

(A) Differential ASSY

- 2) Install the O-rings from left and right side retainer.
- 3) Using ST, install the side retainers. <Ref. to 4AT-99, REMOVAL, Front Differential Assembly.>
ST 499787000 WRENCH ASSY
- 4) Adjust the front differential backlash. <Ref. to 4AT-103, ADJUSTMENT, Front Differential Assembly.>
- 5) Install the lock plate.

Tightening torque:

25 N·m (2.5 kgf·m, 18.4 ft·lb)

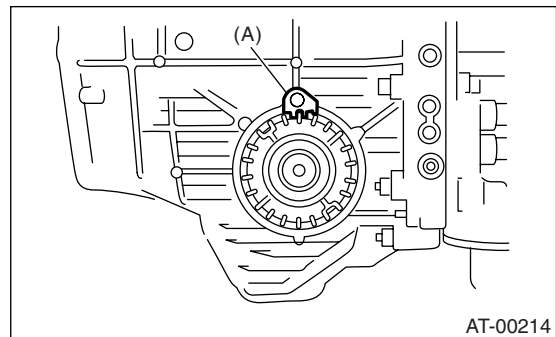

(A) Lock plate

Front Differential Assembly

AUTOMATIC TRANSMISSION

6) Install the new seal pipe to the converter case.

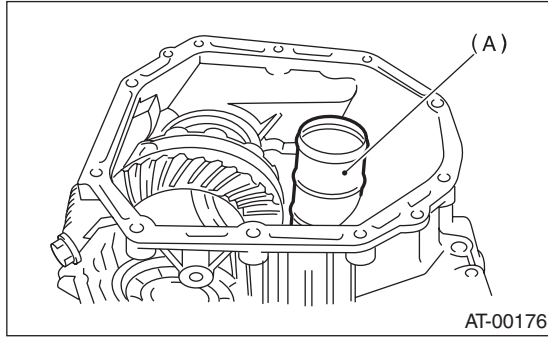

(A) Seal pipe

7) Install the converter case to transmission case. <Ref. to 4AT-87, INSTALLATION, Converter Case.>

8) Insert inhibitor switch and transmission connector into stay.

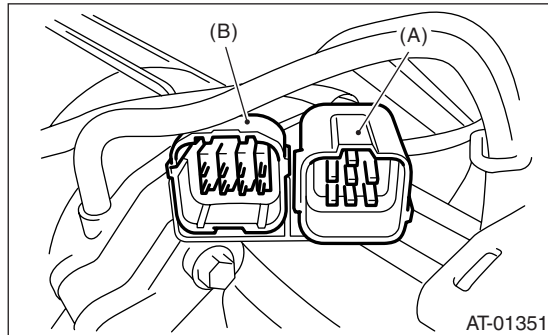

(A) Transmission harness
(B) Inhibitor switch harness

9) Install oil cooler pipes. <Ref. to 4AT-63, INSTALLATION, ATF Cooler Pipe and Hose.>

10) Install the oil charge pipe with O-ring. <Ref. to 4AT-66, INSTALLATION, Oil Charge Pipe.>

11) Insert the input shaft while rotating it lightly by hand, and then check the protrusion amount.

Normal protrusion amount A:
50 — 55 mm (1.97 — 2.17 in)

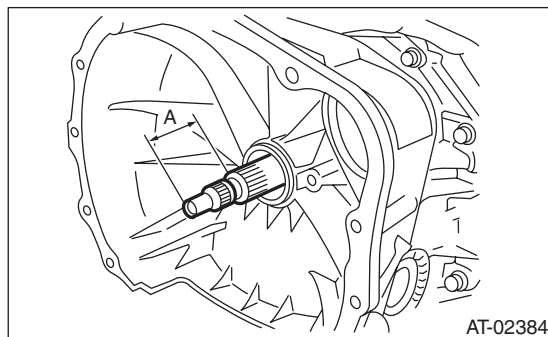

12) Install the torque converter clutch assembly. <Ref. to 4AT-67, INSTALLATION, Torque Converter Clutch Assembly.>

13) Install the transmission assembly to the vehicle. <Ref. to 4AT-40, INSTALLATION, Automatic Transmission Assembly.>

C: DISASSEMBLY

1. DIFFERENTIAL CASE ASSEMBLY

1) Using a press and ST, remove the taper roller bearing.

ST 498077000 REMOVER

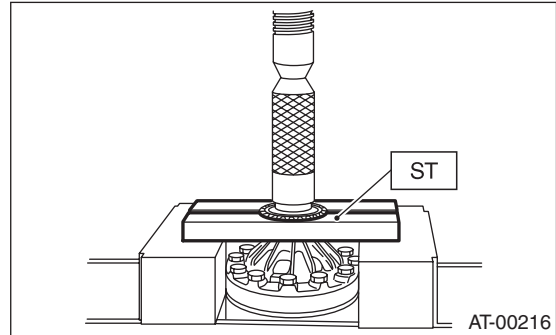

2) Secure the case in a vise and remove the hypoid driven gear tightening bolts, then separate the hypoid driven gear, case (RH) and case (LH).

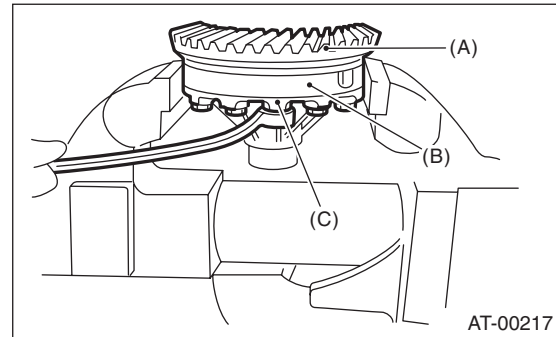

(A) Hypoid driven gear
(B) Differential case (RH)
(C) Differential case (LH)

3) Pull out the straight pin and shaft, and remove the differential bevel gear, washer, and differential bevel pinion.

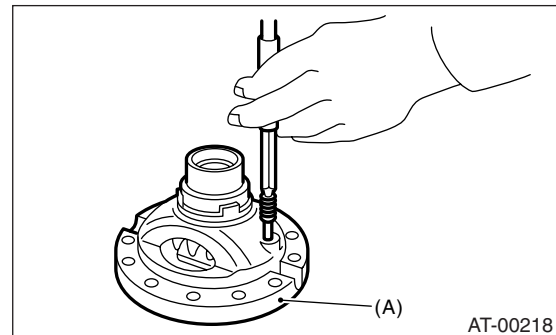

(A) Differential case (RH)

2. SIDE RETAINER

NOTE:

After adjusting the drive pinion backlash and tooth contact, remove and install the oil seal and O-ring.

1) Remove O-ring.

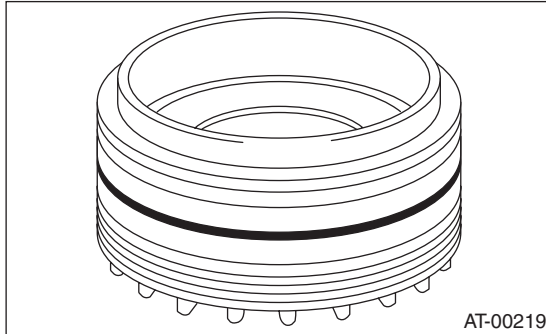

2) Remove oil seal.

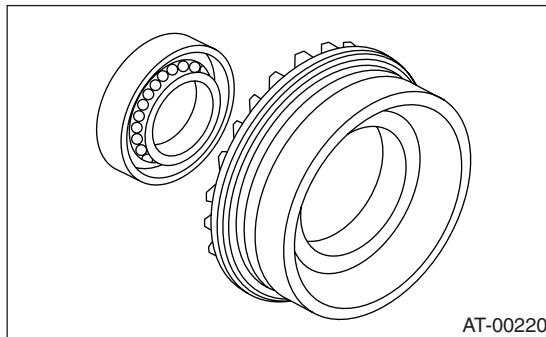

3) Take out either split pin, remove claw.

ST 398527700 PULLER ASSY

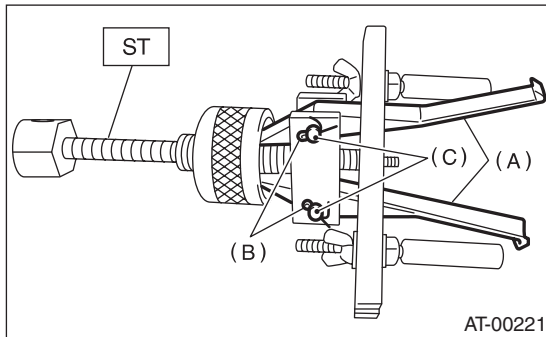

- (A) Claw
- (B) Split pin
- (C) Pin

4) Securely attach two claws to outer race, set ST to side retainer.

ST 398527700 PULLER ASSY

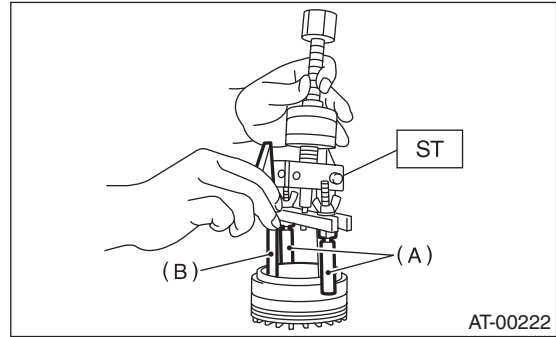

- (A) Shaft
- (B) Claw

5) Return removed claw to the original position, and install pin and split pin.

6) Hold the shaft of ST to avoid removing from side retainer, and then remove the bearing outer race.

ST 398527700 PULLER ASSY

NOTE:

Replace bearing inner and outer races as a single unit.

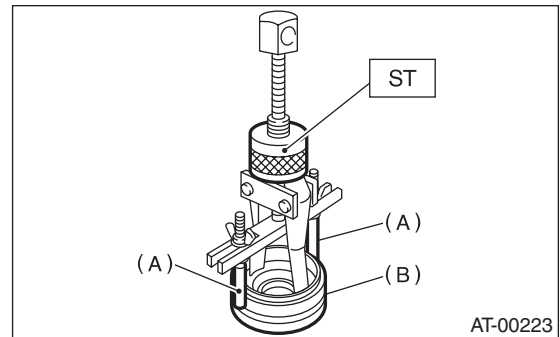

- (A) Shaft
- (B) Side retainer

D: ASSEMBLY

1. DIFFERENTIAL CASE ASSEMBLY

1) Install the washer, differential bevel gear and differential bevel pinion in the differential case (RH). Insert the pinion shaft.

Front Differential Assembly

AUTOMATIC TRANSMISSION

2) Install straight pin from reverse direction.

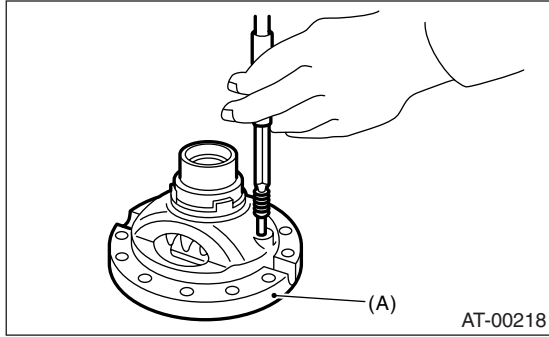

(A) Differential case (RH)

3) Install the washer and differential bevel gear to the differential case (LH). Then put the case over the differential case (RH), and connect both cases.
4) Install the hypoid driven gear and secure by tightening the bolt.

Standard tightening torque:
62 N·m (6.3 kgf·m, 45.7 ft·lb)

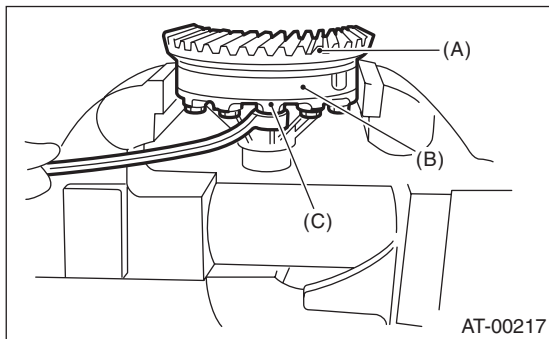

(A) Hypoid driven gear
(B) Differential case (RH)
(C) Differential case (LH)

5) Measurement of backlash (Selection of washer)

(1) Install the genuine axle shaft to differential case.

Part No. 38415AA070 AXLE SHAFT

(2) Measure the gear backlash with ST1 and ST2, and insert ST2 through the access window of the case.

ST1 498247001 MAGNET BASE

ST2 498247100 DIAL GAUGE

NOTE:

- Measure the backlash by applying a pinion tooth between two bevel gear teeth.
- Fix bevel pinion gear in place with a screwdriver or similar tool when measuring.

Standard value:

0.13 — 0.18 mm (0.0051 — 0.0071 in)

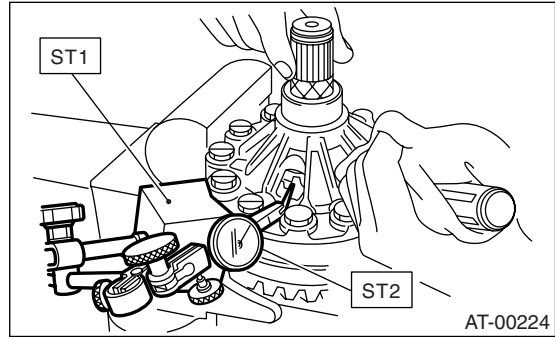

(3) If backlash is not as specified, select a washer from the table below.

Washer	
Part No.	Thickness mm (in)
803038021	0.95 (0.037)
803038022	1.00 (0.039)
803038023	1.05 (0.041)

6) Using ST, install taper roller bearing.

ST 398437700 DRIFT

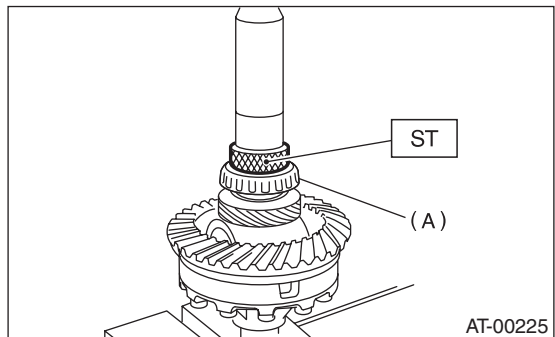

(A) Taper roller bearing

2. SIDE RETAINER

1) Install bearing outer race to side retainer.

2) Install a new oil seal using the ST and hammer.

ST 18675AA000 DIFFERENTIAL SIDE OIL SEAL INSTALLER

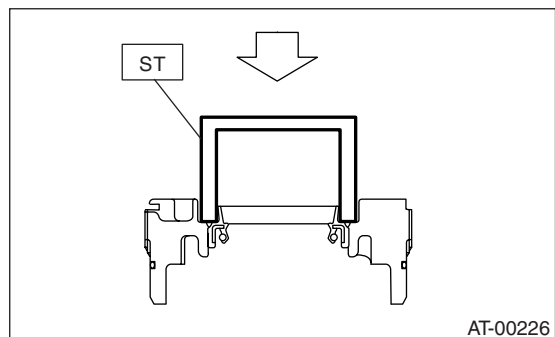

3) Apply gear oil to new O-ring and install it.

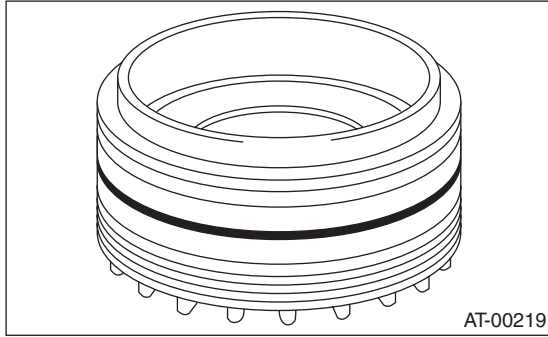

E: INSPECTION

- Check each component for harmful cuts, damage and other faults.
- Measure the backlash and adjust to within specifications.

<Ref. to 4AT-103, ADJUSTMENT, Front Differential Assembly.>

F: ADJUSTMENT

1) Using ST, screw in the retainer until light contact is felt.

NOTE:

Screw in the RH side slightly deeper than the LH side.

ST 499787000 WRENCH ASSY

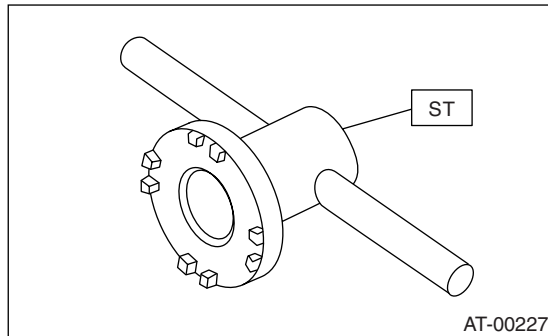

- 2) Remove the oil pump housing.
- 3) Thoroughly remove the liquid gasket from the case mating surface beforehand.
- 4) Install the oil pump housing assembly to the converter case, and secure evenly by tightening four bolts.

NOTE:

Use an old gasket or an aluminum washer so as not to damage the mating surface of the housing.

Tightening torque:

41 N·m (4.2 kgf-m, 30.2 ft-lb)

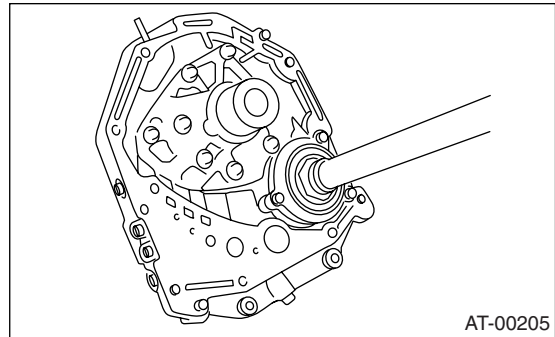

5) Rotate the drive pinion several times with ST1 and ST2.

ST1 498937110 HOLDER
ST2 499787700 WRENCH

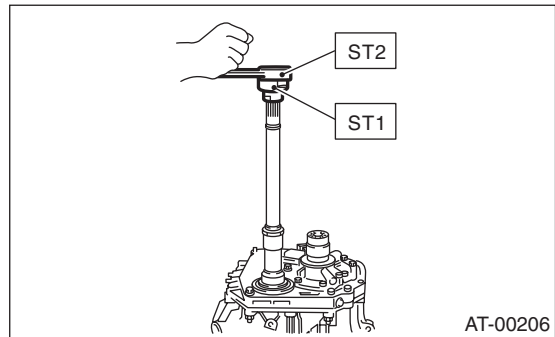

6) Tighten the LH retainer until contact is felt while rotating the shaft. Then loosen the RH retainer. Keep tightening the LH retainer and loosening the RH retainer until the pinion shaft can no longer be turned. This is the "zero" state.

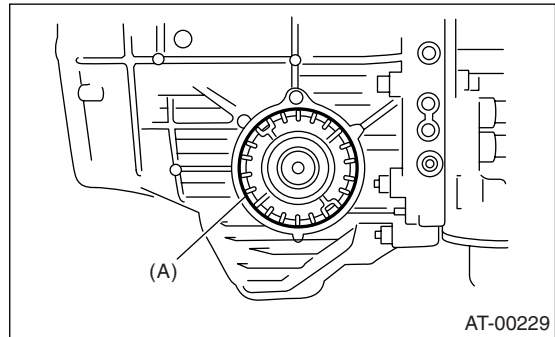

(A) Retainer

Front Differential Assembly

AUTOMATIC TRANSMISSION

7) After the “zero” state is established, back off the LH retainer 3 notches and secure it with the lock plate. Then back off the RH retainer and retighten until it stops. Rotate drive pinion a few times. Tighten the RH retainer 1-3/4 notches further. This sets the preload. Finally, secure the retainer with its lock plate.

9) Adjust the tooth contact between front differential and drive shaft. <Ref. to 4AT-97, ADJUSTMENT, Drive Pinion Shaft Assembly.>

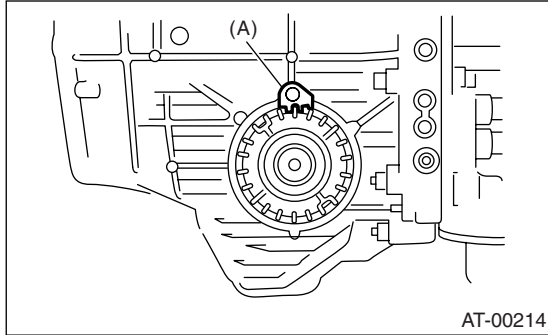

(A) Lock plate

NOTE:

Turning the retainer by one tooth changes the backlash about 0.05 mm (0.0020 in).

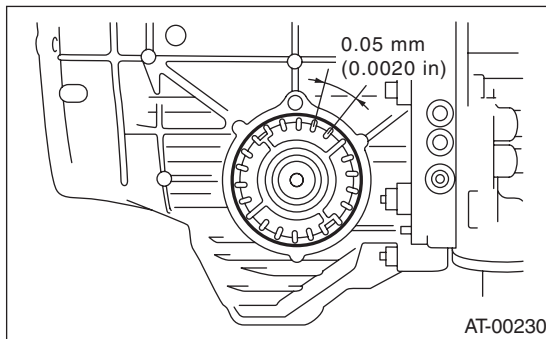

8) Turn the drive pinion several rotations with ST1 and check to see if the backlash is within the standard value with ST2, ST3, ST4 and ST5.

ST1	499787700	WRENCH
ST2	498247001	MAGNET BASE
ST3	498247100	DIAL GAUGE
ST4	499787500	ADAPTER
ST5	498255400	PLATE

Backlash:

0.13 — 0.18 mm (0.0051 — 0.0071 in)

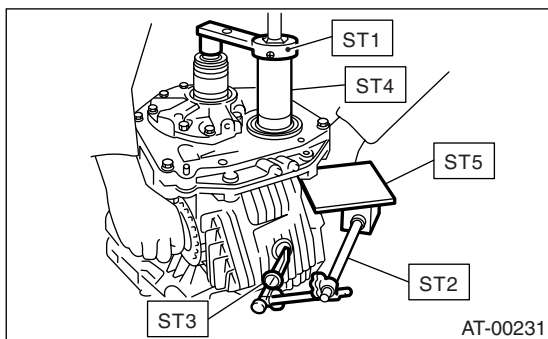

37.AT Main Case

A: REMOVAL

- 1) Remove the transmission assembly from the vehicle. <Ref. to 4AT-38, REMOVAL, Automatic Transmission Assembly.>
- 2) Extract the torque converter clutch assembly. <Ref. to 4AT-67, REMOVAL, Torque Converter Clutch Assembly.>
- 3) Remove the input shaft.

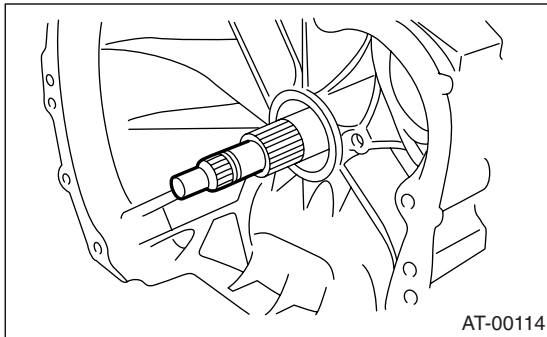

- 4) Lift-up lever behind the transmission harness connector and disconnect it from stay.
- 5) Disconnect inhibitor switch connector from stay.
- 6) Disconnect the air breather hose.
- 7) Remove the oil charge pipe. <Ref. to 4AT-66, REMOVAL, Oil Charge Pipe.>
- 8) Remove the oil cooler inlet and outlet pipes. <Ref. to 4AT-63, REMOVAL, ATF Cooler Pipe and Hose.>
- 9) Separation of converter case and transmission case. <Ref. to 4AT-87, REMOVAL, Converter Case.>
- 10) Remove the oil pump housing. <Ref. to 4AT-89, REMOVAL, Oil Pump Housing.>
- 11) Take out the high clutch, thrust needle bearing and reverse clutch assembly.

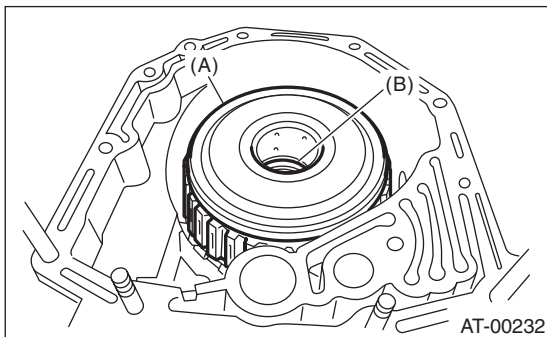

- (A) High clutch and reverse clutch ASSY
- (B) Thrust needle bearing

- 12) Take out the high clutch hub and the thrust bearing.

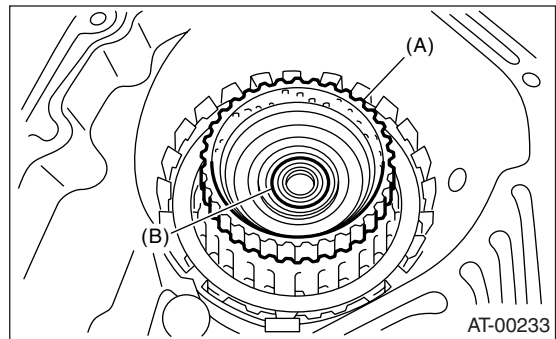

- (A) High clutch hub
- (B) Thrust needle bearing

- 13) Take out the front sun gear and the thrust bearing.

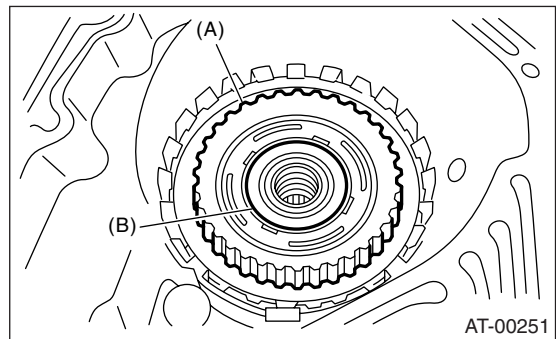

- (A) Front sun gear
- (B) Thrust needle bearing

- 14) Pull out leaf spring without folding.

NOTE:

Remove it while pressing down on lower leaf spring.

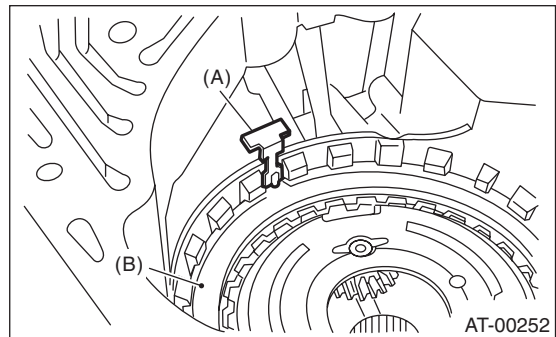

- (A) Leaf spring
- (B) Retaining plate

AT Main Case

AUTOMATIC TRANSMISSION

15) Remove snap ring and thrust needle bearing.

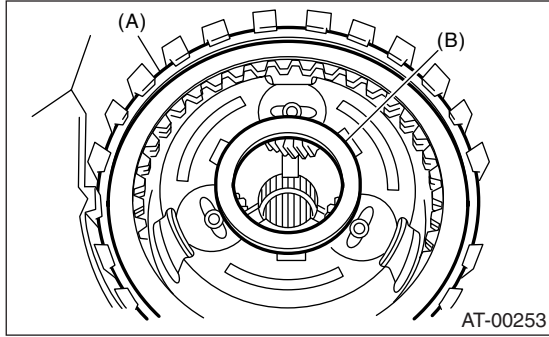

- (A) Snap ring
- (B) Thrust needle bearing

16) Take out retaining plate, drive plate and driven plate of 2-4 brake.

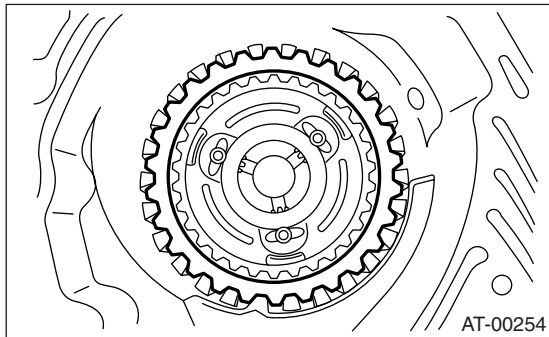

17) Take out the thrust needle bearing, planetary gear assembly and the low clutch assembly.

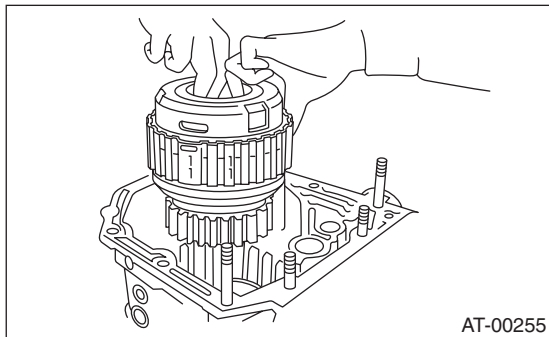

18) Remove 2-4 brake seal.

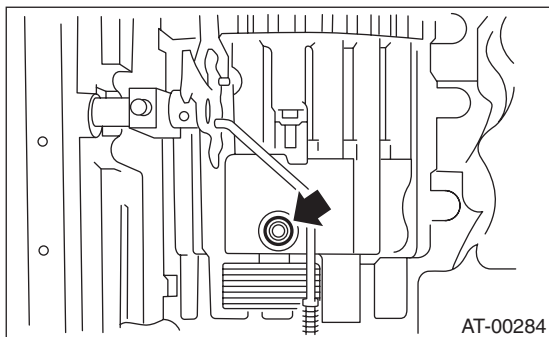

19) Remove snap ring.

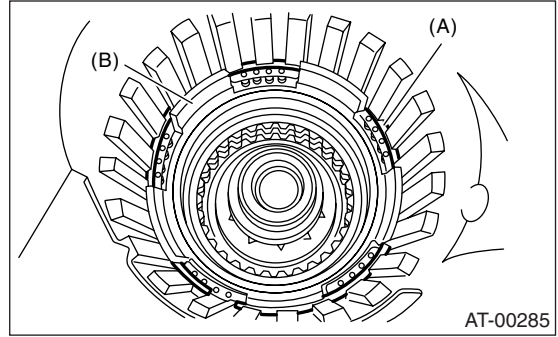

- (A) Snap ring
- (B) 2-4 brake piston

20) Take out 2-4 brake return spring.

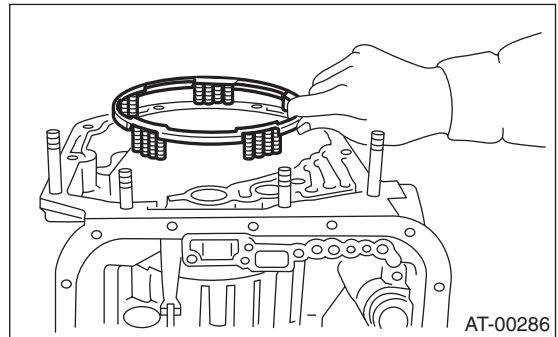

21) Remove the 2-4 brake piston and piston retainer without damaging.

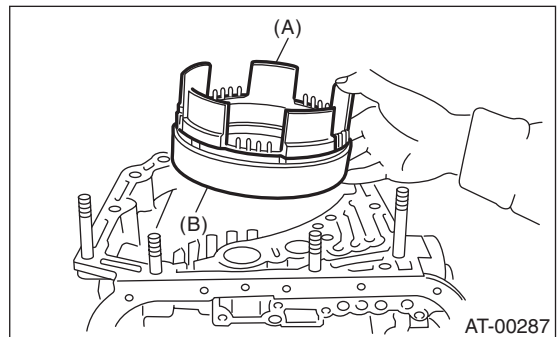

- (A) 2-4 brake piston
- (B) 2-4 brake piston retainer

22) Pull out the leaf spring without folding.

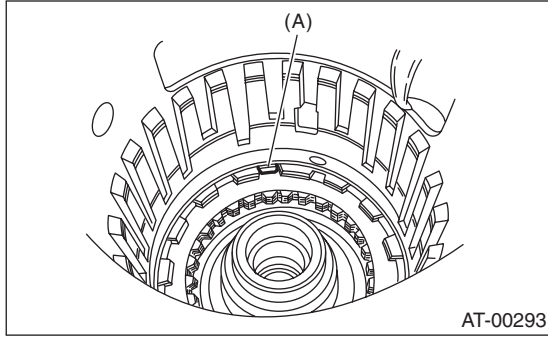

(A) Leaf spring

23) Remove snap ring.

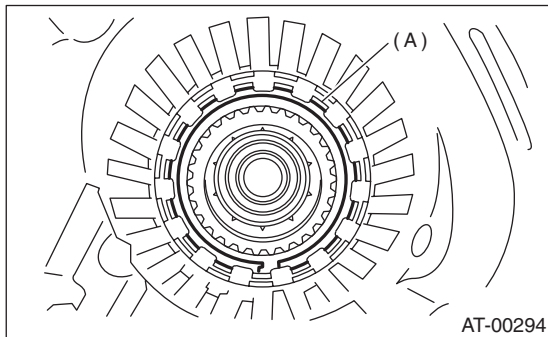

(A) Snap ring

24) Take out retaining plate, drive plate, driven plate and dish plate.

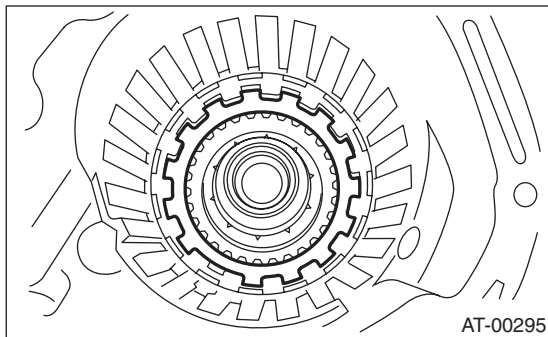

25) Turn the transmission case upside down, and then take out the socket bolts while holding the one-way clutch inner race with hand.

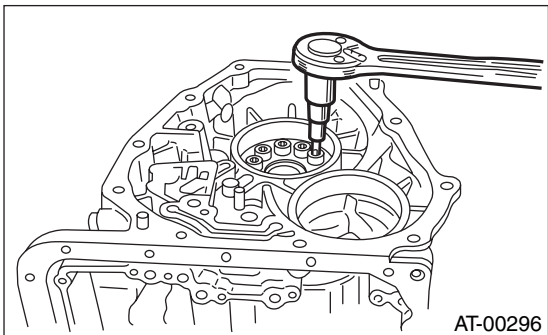

26) Take out the spring retainer.

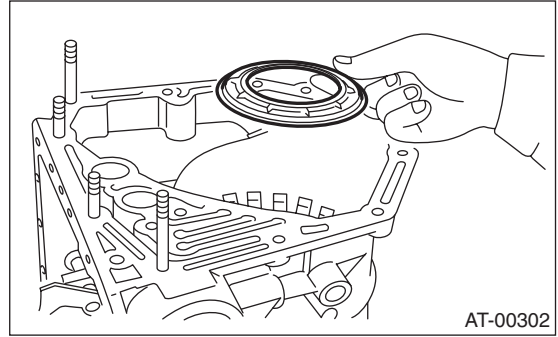

27) Take out the return spring.

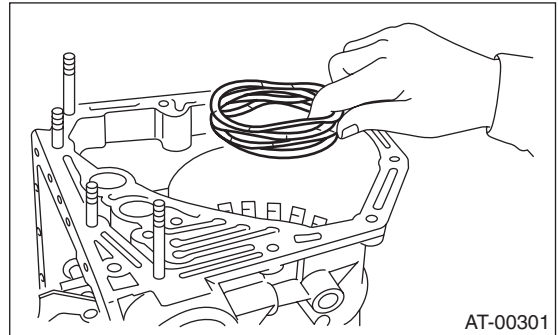

28) Apply compressed air.

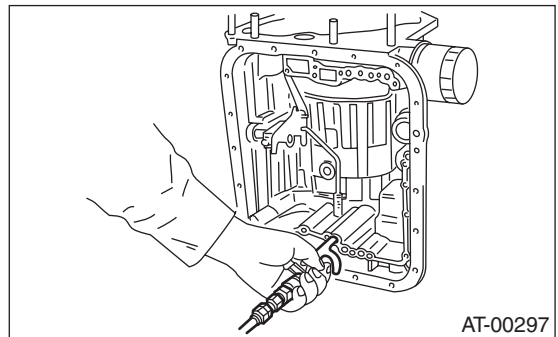

29) Take out the low & reverse piston.

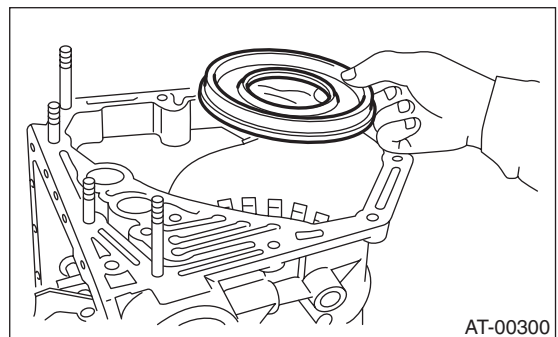

AT Main Case

AUTOMATIC TRANSMISSION

B: INSTALLATION

1) Install the low & reverse piston without tilting.

NOTE:

Be careful not to damage the lip seal.

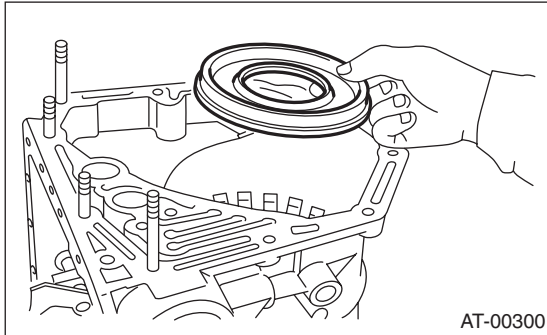

2) Install return spring.

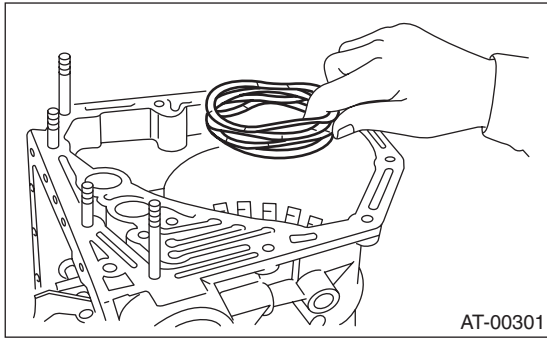

3) Install spring retainer.

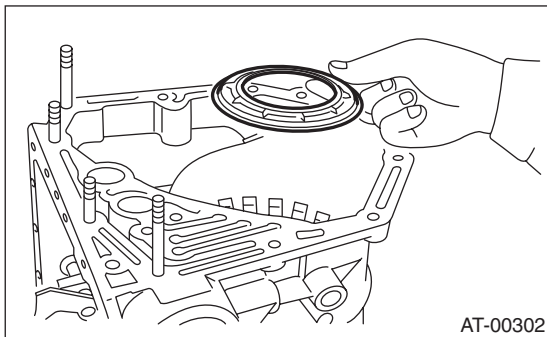

4) Install the one-way clutch inner race, spring retainer and return spring.

5) Tighten socket head bolts evenly from the rear side of the transmission case.

Tightening torque:

25 N·m (2.5 kgf·m, 18.4 ft·lb)

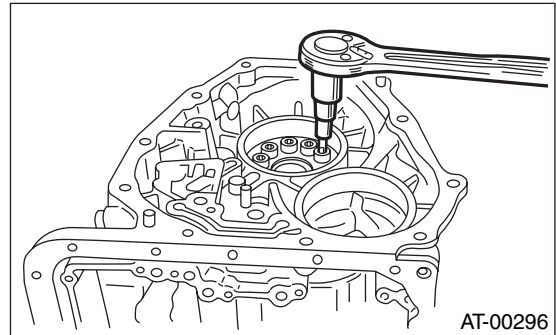

6) Place the front side of transmission body up.

7) Install thrust needle bearing.

8) Place the dish plate, driven plate, drive plate and retaining plate neatly in this order on surface table.

9) Set the micro gauge to retaining plate, and read its scale. Make more than three measurements at even distance and take the average value.

NOTE:

The value, which is read in the gauge at this time, is zero point.

10) Scale and record the weight Z of a flat board which will be put on plates.

NOTE:

- Use a stiff flat board which does not bend against load.

- Use a flat board of its weight less than 8.5 kg (18.7 lb).

11) Put the flat board on retaining plate.

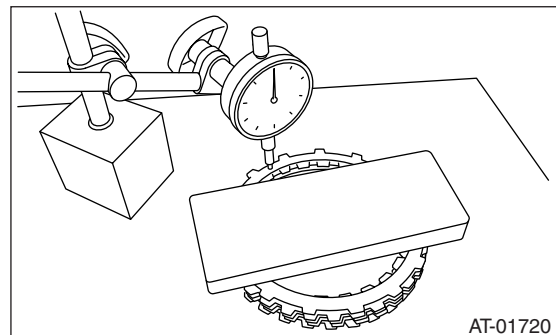

12) Using the following formula, calculate N indicated on the push/pull gauge.

$$N = 83 \text{ N (8.5 kgf, 18.7 lbf)} - Z$$

N: Value indicated on push/pull gauge

83 N (8.5 kgf, 18.7 lbf): Load applied to clutch plate

Z: Flat board weight

13) Press the center of retaining plate applying force of N with push/pull gauge, and then measure and record the height "A". Make more than three measurements at even distance and take the average value.

NOTE:

If three points, measure the height every 120°. If four points, measure the height every 90°.

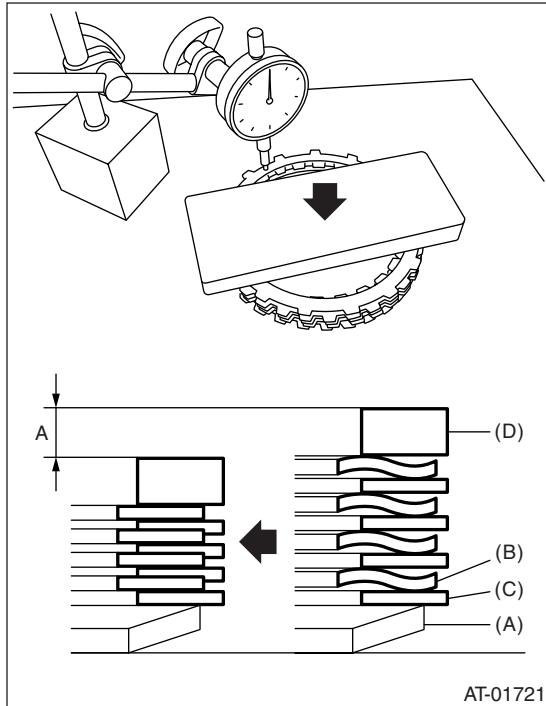

- (A) Dish plate
- (B) Driven plate
- (C) Drive plate
- (D) Retaining plate

14) Installation of the low & reverse brake:
Install the dish plate, driven plate and retaining plate, and then secure them with snap ring.

NOTE:

Pay attention to the orientation of dish plate.

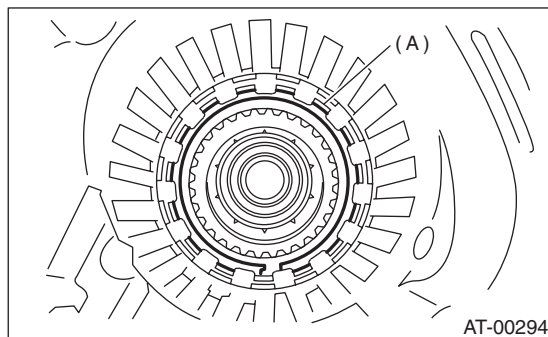

- (A) Snap ring

15) Apply compressed air intermittently to check for operation.

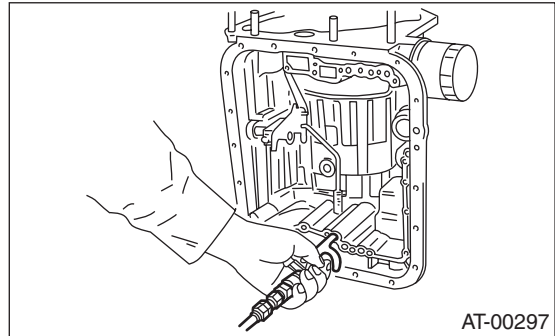

16) Place the same thickness of shim on both sides to prevent the plate from tilting, and then measure and record the clearance "B".

NOTE:

Do not press the shim downward with excessive force, or else the waveform of drive plates will be broken down.

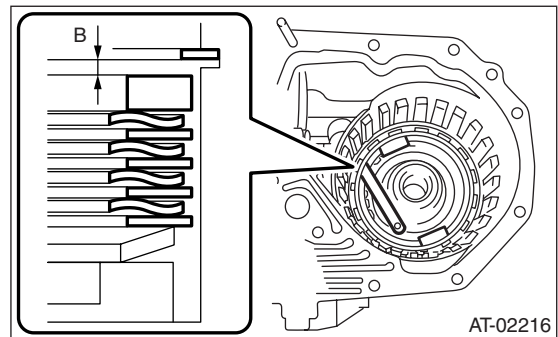

17) Piston stroke calculation

Calculate with "A" and "B" dimensions which have been recorded before, and if the value exceeds the service limit, replace the drive plate with a new one and adjust it within the specification.

$$T = A + B$$

T: Piston stroke

A: Collapse amount of drive plate

B: Clearance between retaining plate and snap ring

Non-turbo model

Initial standard:

2.15 — 2.65 mm (0.073 — 0.093 in)

Limit thickness:

2.95 mm (0.104 in)

Turbo model

Initial standard:

2.70 — 3.20 mm (0.106 — 0.126 in)

Limit thickness:

3.90 mm (0.154 in)

AT Main Case

AUTOMATIC TRANSMISSION

Retaining plate	
Part number	Thickness mm (in)
31667AA420	3.8 (0.150)
31667AA320	4.1 (0.161)
31667AA330	4.4 (0.173)
31667AA340	4.7 (0.185)
31667AA350	5.0 (0.197)
31667AA360	5.3 (0.209)
31667AA370	5.6 (0.220)
31667AA380	5.9 (0.232)

NOTE:

Do not make adjustment unless the drive plate is replaced.

18) Install the low & reverse brake leaf spring.

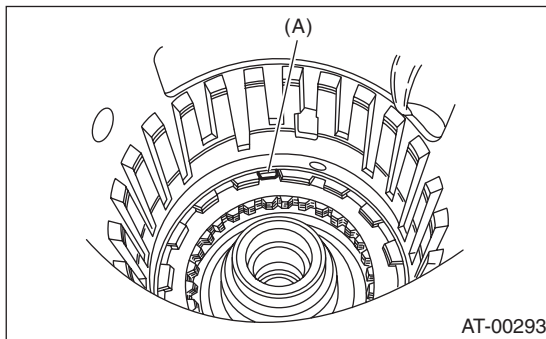

(A) Leaf spring

19) Install the 2-4 brake piston and 2-4 brake retainer by aligning hole of 2-4 brake retainer and hole of transmission case.

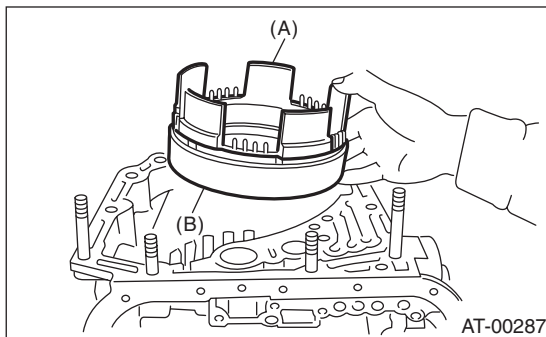

(A) 2-4 brake piston
(B) 2-4 brake piston retainer

20) Install 2-4 brake piston return spring to transmission case.

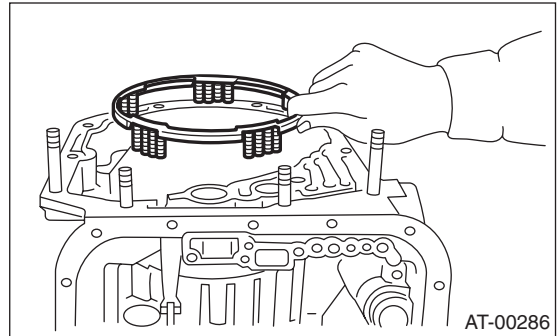

21) Position snap ring in transmission. Using ST, press the snap ring into place.

ST 498677100 COMPRESSOR

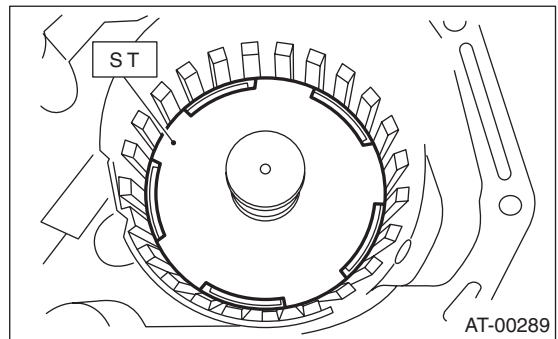

22) Install planetary gear and low clutch assembly to transmission case.

CAUTION:
If installing it while rotating the low clutch and planetary gear assembly, rotate them slowly and pay attention not to damage the seal ring.

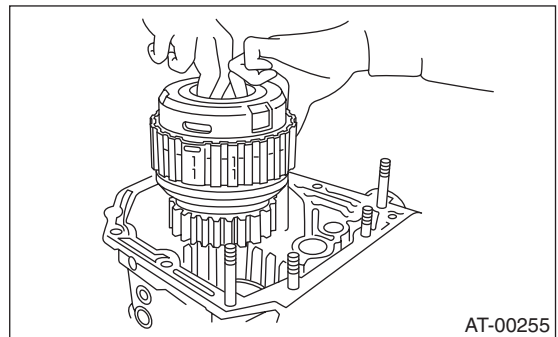

23) Selection of 2-4 brake retaining plate (Turbo model)

- (1) Install pressure plate, drive plate, driven plate, retaining plate and snap ring.

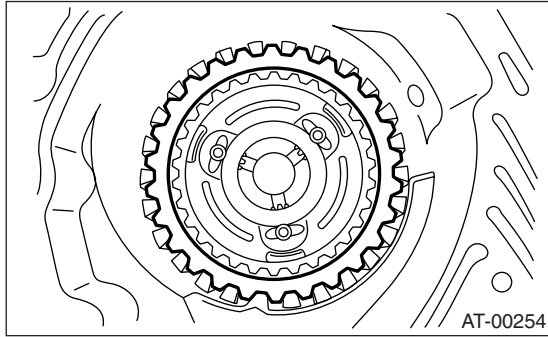

- (2) Install a new 2-4 brake oil seal to transmission case.

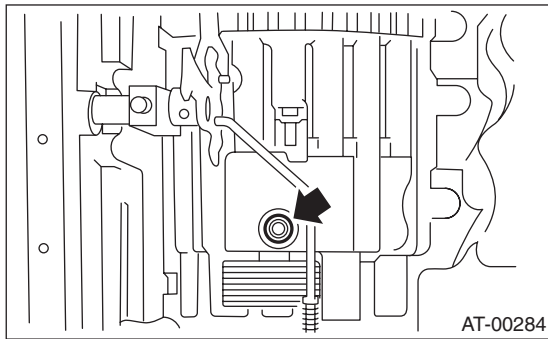

- (3) After all 2-4 brake component parts have been installed, blow in air intermittently and confirm the operation of the brake.

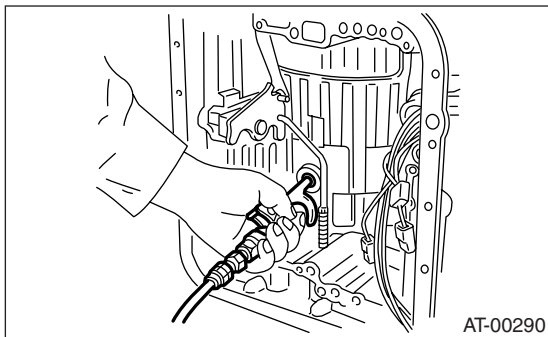

- (4) Check the clearance between the retaining plate and the snap ring.

NOTE:

Do not make adjustment unless the drive plate is replaced.

If it exceeds the service limit, replace the drive plate with a new one and adjust it within the specification.

Initial standard:

0.8 — 1.2 mm (0.031 — 0.047 in)

Limit thickness:

1.5 mm (0.059 in)

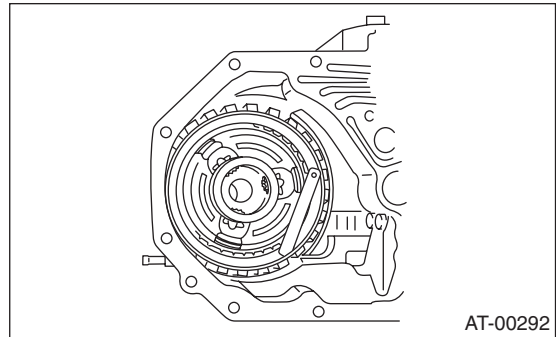

Retaining plate	
Part No.	Thickness mm (in)
31567AA991	5.6 (0.220)
31567AB001	5.8 (0.228)
31567AB011	6.0 (0.236)
31567AB021	6.2 (0.244)
31567AB031	6.4 (0.252)
31567AB041	6.6 (0.260)

- 24) Selection of 2-4 brake retaining plate (Non-turbo model)

(1) Place the dish plate, driven plate, drive plate and retaining plate neatly in this order on surface table.

(2) Set the micro gauge to clutch, and read its scale.

NOTE:

The value, which is read in the gauge at this time, is zero point.

(3) Scale and record the weight Z of a flat board which will be put on plates.

NOTE:

- Use a stiff flat board which does not bend against load.

- Use a flat board of its weight less than 10.2 kg (22.5 lb).

(4) Put the flat board on retaining plate.

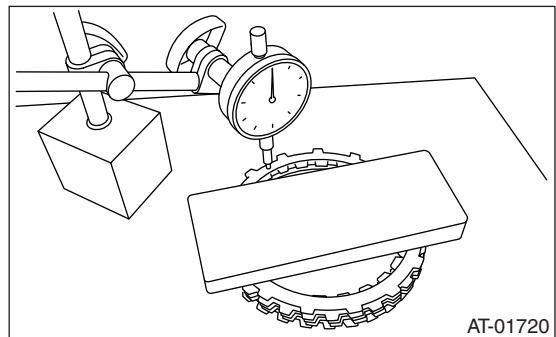

AT Main Case

AUTOMATIC TRANSMISSION

(5) Using the following formula, calculate N indicated on the push/pull gauge.

$$N = 100 N (10.2 \text{ kgf}, 22.5 \text{ lbf}) - Z$$

N: Value indicated on push/pull gauge

100 N (10.2 kgf, 22.5 lbf): Load applied to clutch plate

Z: Flat board weight

(6) Press the center of retaining plate applying force of N with push/pull gauge, and then measure and record the height "A". Make more than three measurements at even distance and take the average value.

NOTE:

If three points, measure the height every 120°. If four points, measure the height every 90°.

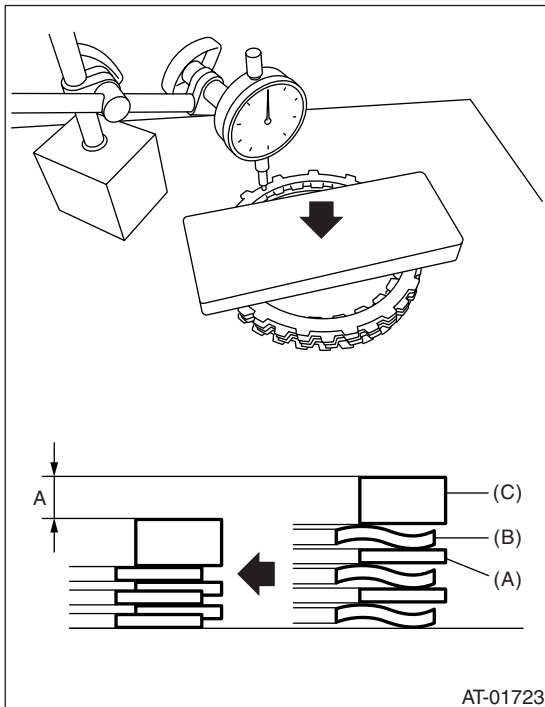

- (A) Driven plate
- (B) Drive plate
- (C) Retaining plate

(7) Install the pressure plate, drive plate, driven plate, retaining plate and snap ring.

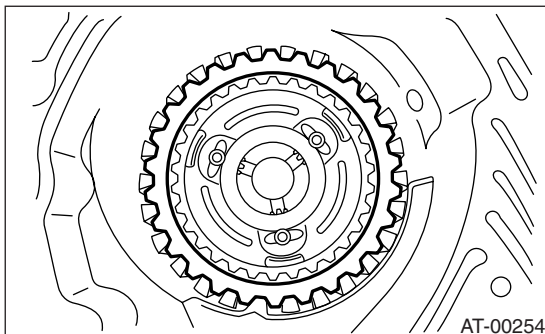

(8) Install a new 2-4 brake oil seal to transmission case.

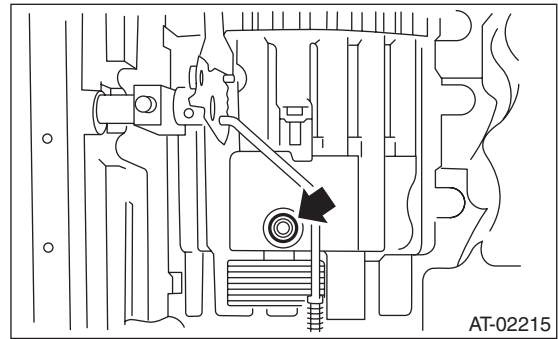

(9) After all 2-4 brake component parts have been installed, blow air intermittently and confirm the operation of brake.

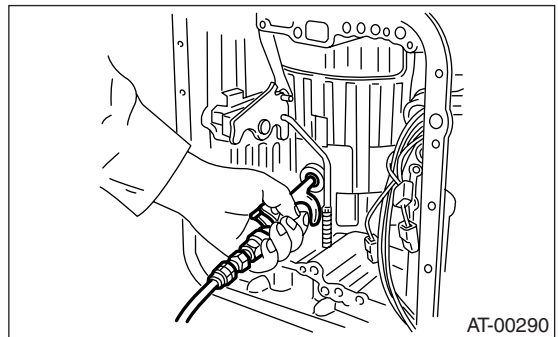

(10) Measure and record the clearance "B" between the retaining plate and snap ring.

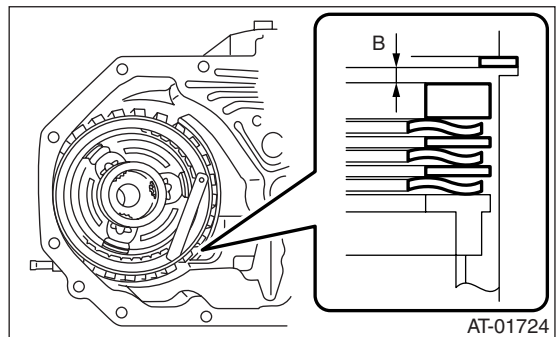

(11) Piston stroke calculation

Calculate with "A" and "B" dimensions which have been recorded before, and if the value exceeds the service limit, replace the drive plate with a new one and adjust it within the specification.

$$T = A + B$$

T: Piston stroke

A: Collapse amount of drive plate

B: Clearance between retaining plate and snap ring

Initial standard:

1.7 — 2.1 mm (0.067 — 0.083 in)

Limit thickness:

2.3 mm (0.091 in)

Retaining plate	
Part number	Thickness mm (in)
31567AA991	5.6 (0.220)
31567AB001	5.8 (0.228)
31567AB011	6.0 (0.236)
31567AB021	6.2 (0.244)
31567AB031	6.4 (0.252)
31567AB041	6.6 (0.260)

NOTE:

Do not make adjustment unless the drive plate is replaced.

25) Be careful not to mistake the location of the leaf spring to be inserted.

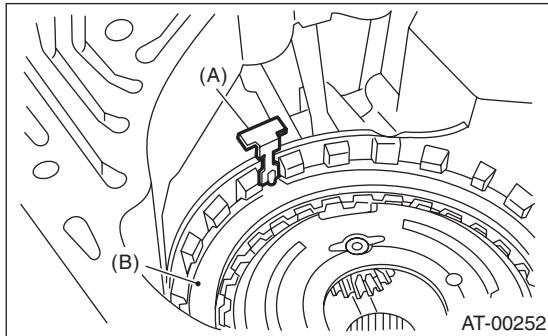

- (A) Leaf spring
- (B) Retaining plate

26) Install thrust needle bearing in the correct direction.

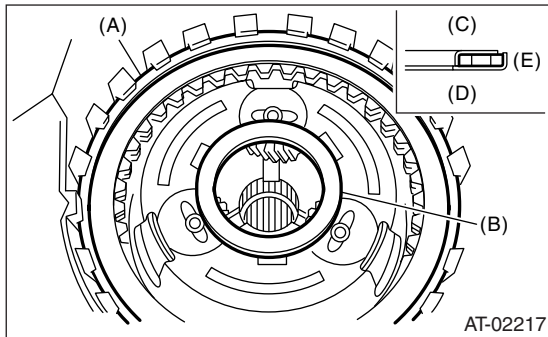

- (A) Snap ring
- (B) Thrust needle bearing
- (C) Upside
- (D) Downside
- (E) Outside

27) Install front sun gear and thrust needle bearing.

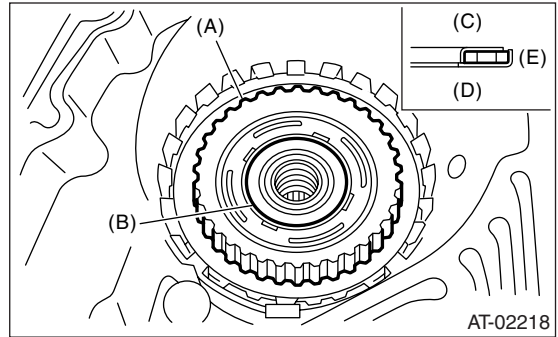

- (A) Front sun gear
- (B) Thrust needle bearing
- (C) Clutch hub side
- (D) Front sun gear side
- (E) Outside

28) Install the high clutch hub.

Attach the thrust needle bearing to the hub with vaseline and install the hub by correctly engaging the splines of the front planetary carrier.

29) Install the thrust needle bearing in proper direction.

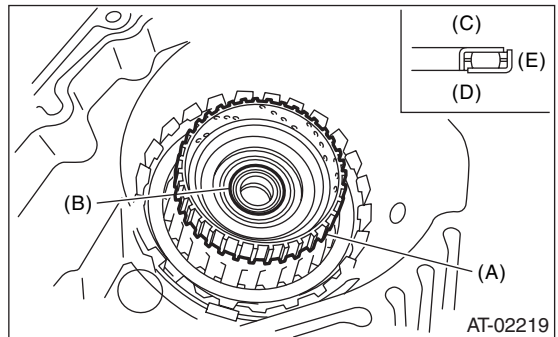

- (A) High clutch hub
- (B) Thrust needle bearing
- (C) Upside
- (D) Downside
- (E) Outside

30) Install the high clutch assembly.

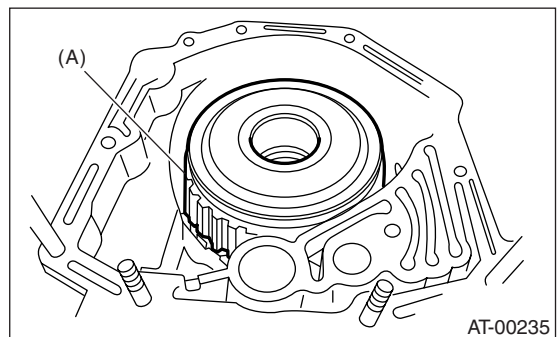

- (A) High clutch and reverse clutch ASSY

AT Main Case

AUTOMATIC TRANSMISSION

31) Adjust total end play. <Ref. to 4AT-93, ADJUSTMENT, Oil Pump Housing.>

32) Install the thrust needle bearing in proper direction.

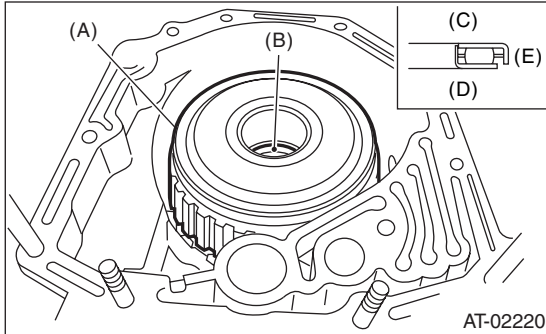

- (A) High clutch and reverse clutch ASSY
- (B) Thrust needle bearing
- (C) Upside
- (D) Downside
- (E) Outside

33) Install the oil pump housing assembly.

34) Install the converter case assembly to the transmission case assembly. <Ref. to 4AT-87, INSTALLATION, Converter Case.>

35) Insert inhibitor switch and transmission connector into stay.

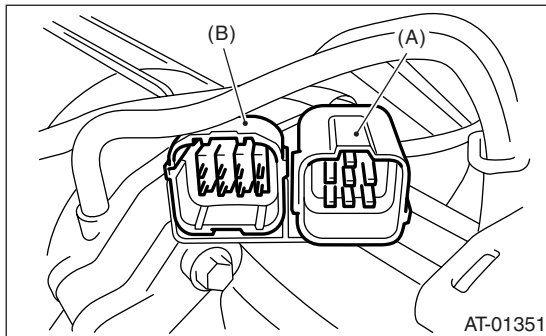

- (A) Transmission harness
- (B) Inhibitor switch harness

36) Install air breather hose. <Ref. to 4AT-65, INSTALLATION, Air Breather Hose.>

37) Install oil cooler pipes. <Ref. to 4AT-63, INSTALLATION, ATF Cooler Pipe and Hose.>

38) Install the oil charge pipe with O-ring. <Ref. to 4AT-66, INSTALLATION, Oil Charge Pipe.>

39) Insert the input shaft while rotating it lightly by hand, and then check the protrusion amount.

Normal protrusion amount A:
50 — 55 mm (1.97 — 2.17 in)

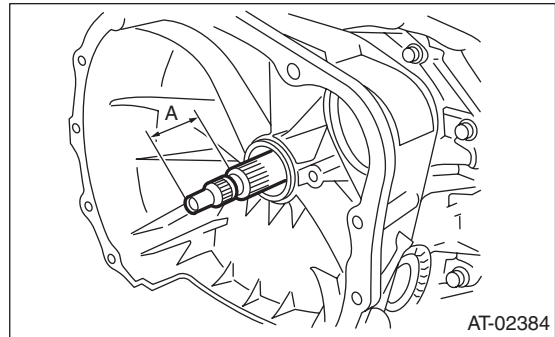

40) Install the torque converter clutch assembly. <Ref. to 4AT-67, INSTALLATION, Torque Converter Clutch Assembly.>

41) Install the transmission assembly to the vehicle. <Ref. to 4AT-40, INSTALLATION, Automatic Transmission Assembly.>

C: DISASSEMBLY

1. HIGH CLUTCH, REVERSE CLUTCH

1) Remove the snap ring, and take out the retaining plate, drive plates, driven plates.

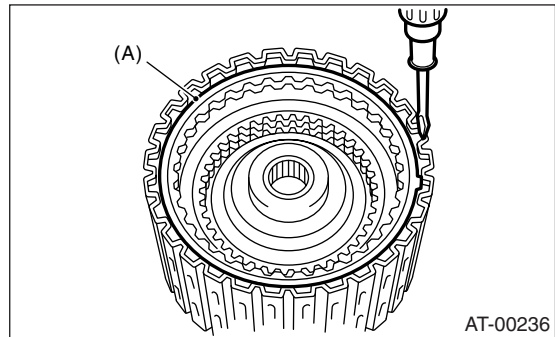

(A) Snap ring

2) Remove snap ring, and take out the retaining plate, drive plates and driven plates.

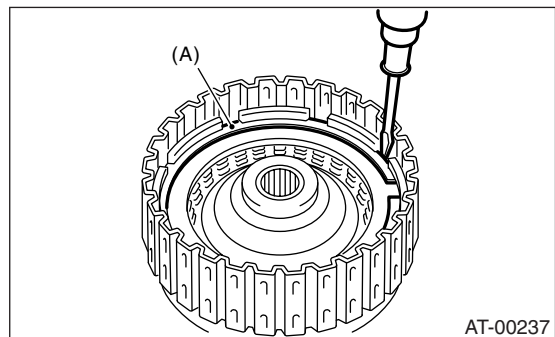

(A) Snap ring

3) Using ST1 and ST2, remove snap ring.
ST1 398673600 COMPRESSOR

ST2 498627100 SEAT

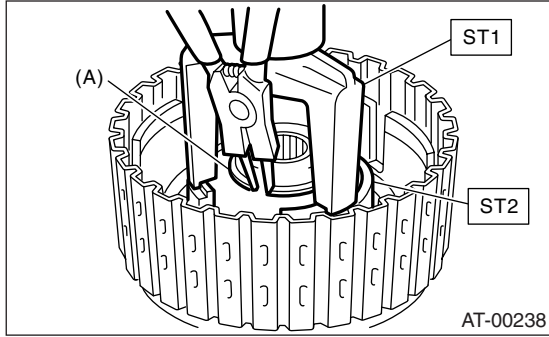

(A) Snap ring

4) Take out clutch cover, spring retainer, high clutch piston and reverse clutch piston.

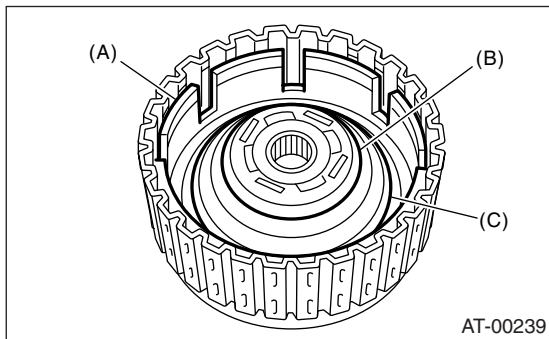

(A) Reverse clutch piston
(B) Cover
(C) Return spring

5) Remove seal rings and lip seal from high clutch piston and reverse clutch piston.

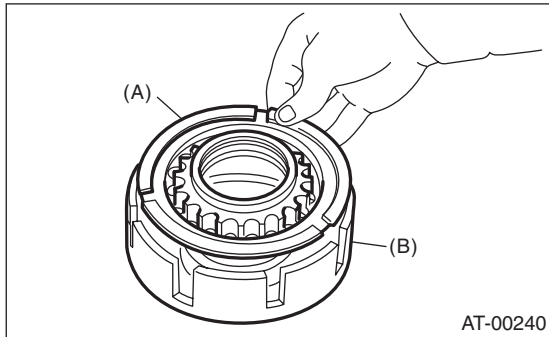

(A) High clutch piston
(B) Reverse clutch piston

2. PLANETARY GEAR, LOW CLUTCH

1) Remove snap ring from the low clutch drum.

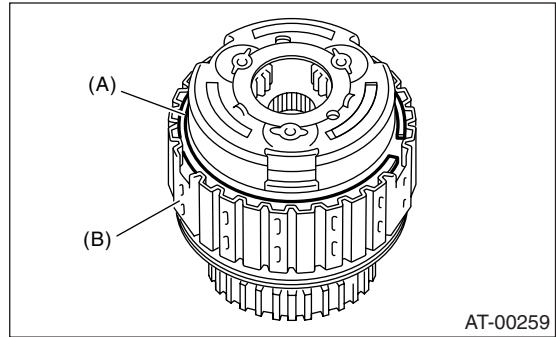

(A) Snap ring
(B) Low clutch drum

2) Take out front planetary carrier.

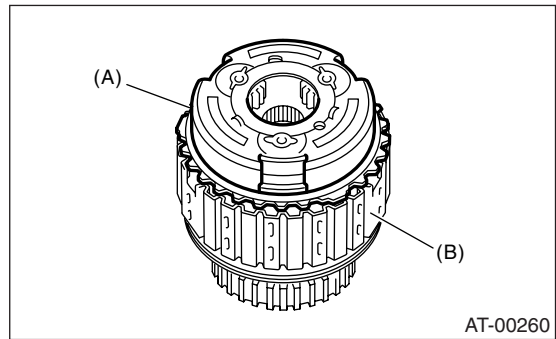

(A) Front planetary carrier
(B) Low clutch drum

3) Take out rear sun gear.

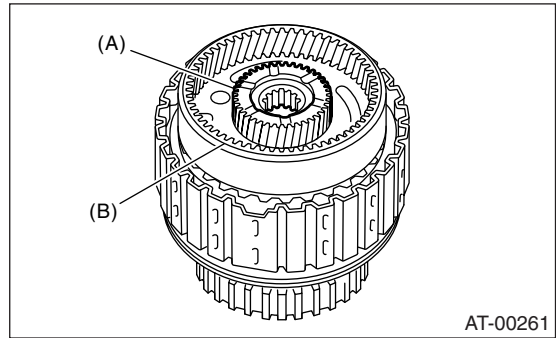

(A) Rear sun gear
(B) Rear planetary carrier

AT Main Case

AUTOMATIC TRANSMISSION

4) Take out rear planetary carrier, washer and thrust needle bearing.

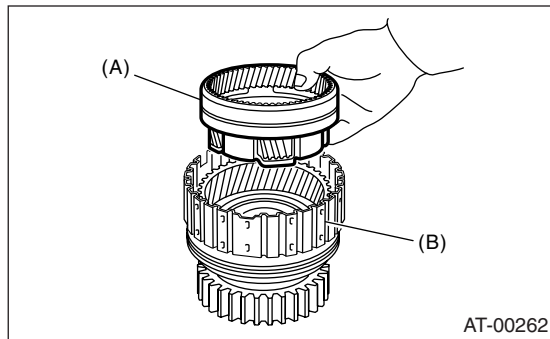

- (A) Rear planetary carrier
- (B) Low clutch drum

5) Take out rear internal gear.

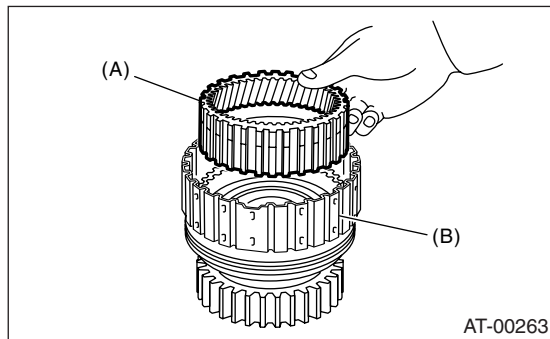

- (A) Rear internal gear
- (B) Low clutch drum

6) Remove the snap ring from the low clutch drum.

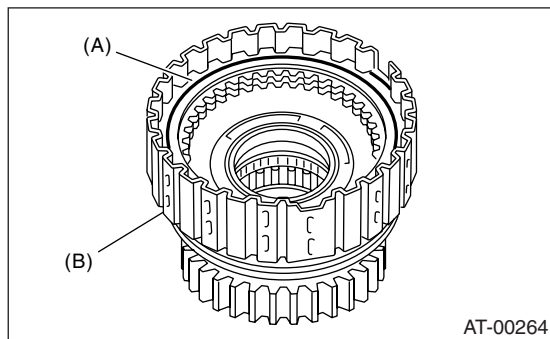

- (A) Snap ring
- (B) Low clutch drum

7) Compress the spring retainer, and remove the snap ring from the low clutch drum, by using ST1 and ST2.

ST1 498627100 SEAT
ST2 398673600 COMPRESSOR

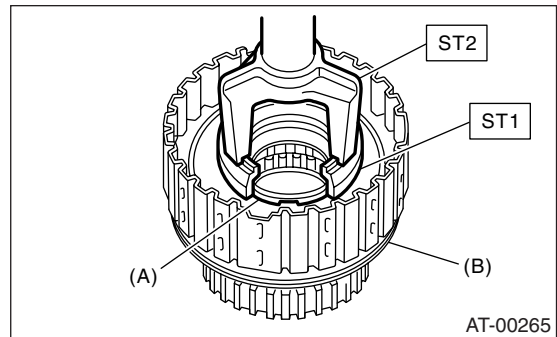

- (A) Snap ring
- (B) Low clutch drum

8) Remove one-way clutch. <Ref. to 4AT-105, REMOVAL, AT Main Case.>

9) Install the one-way clutch inner race to the low clutch drum, and apply compressed air to remove the low clutch piston.

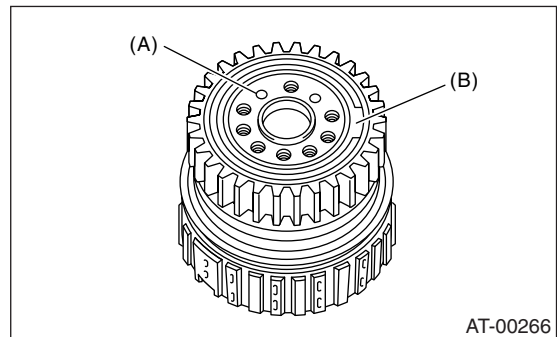

- (A) Apply compressed air.
- (B) One-way clutch inner race

10) Remove the one-way clutch inner race.

11) Remove the one-way clutch after taking out the snap ring.

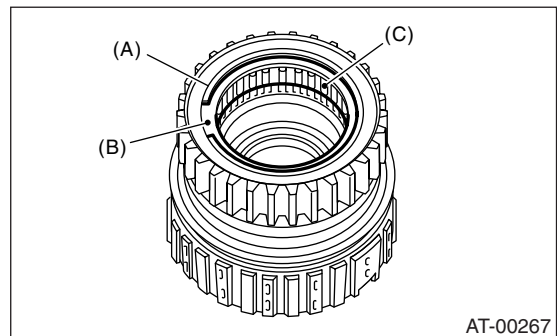

- (A) Snap ring
- (B) Plate
- (C) One-way clutch

12) Remove the needle bearing after taking out the snap ring.

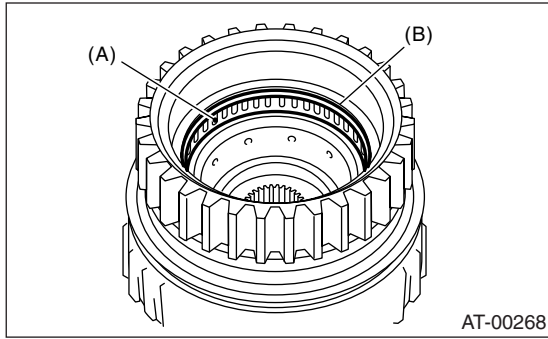

(A) Needle bearing
(B) Snap ring

3. 2-4 BRAKE

1) Separate 2-4 brake piston and piston retainer.

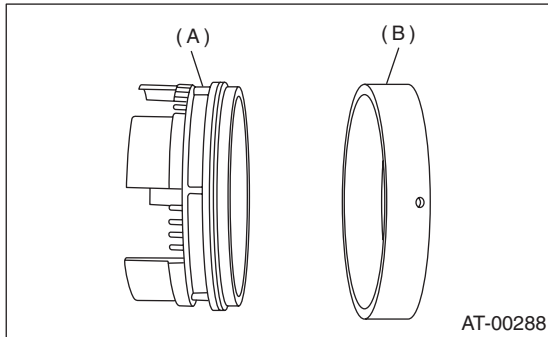

(A) 2-4 brake piston
(B) 2-4 brake piston retainer

2) Remove the D-ring from 2-4 brake piston.

4. ONE-WAY CLUTCH INNER RACE

1) Remove seal rings.

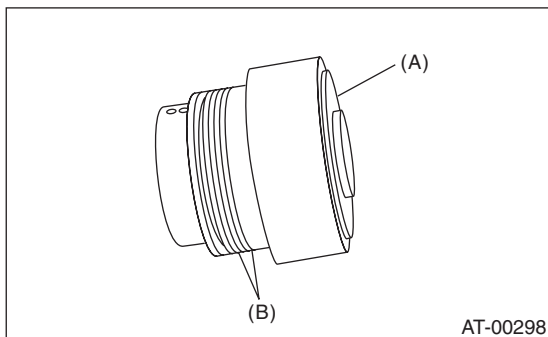

(A) One way clutch inner race
(B) Seal rings

2) Using ST, remove needle bearing.
ST 398527700 PULLER ASSY

5. ONE-WAY CLUTCH OUTER RACE

1) Remove the one-way clutch after taking out the snap ring.

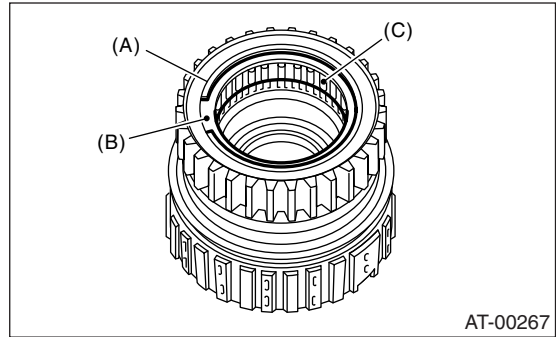

(A) Snap ring
(B) Plate
(C) One-way clutch

2) Remove the needle bearing after taking out the snap ring.

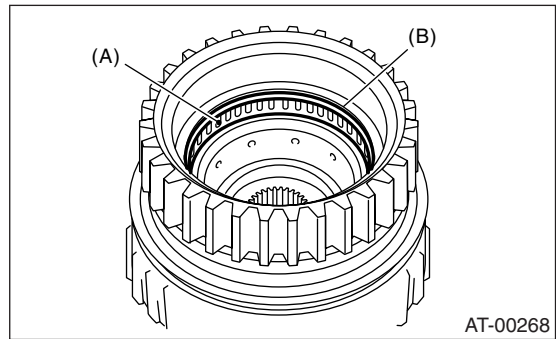

(A) Needle bearing
(B) Snap ring

D: ASSEMBLY

1. HIGH CLUTCH, REVERSE CLUTCH

1) Install seal rings and lip seal to high clutch piston and reverse clutch piston.

2) Install high clutch piston to reverse clutch piston.

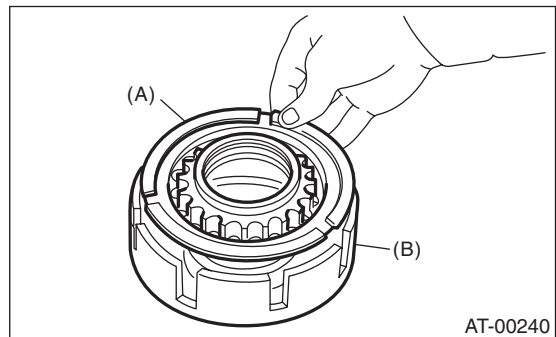

(A) High clutch piston
(B) Reverse clutch piston

AT Main Case

AUTOMATIC TRANSMISSION

3) Install reverse clutch to high clutch drum. Align the groove on the reverse clutch piston with the groove on the high clutch drum during installation.

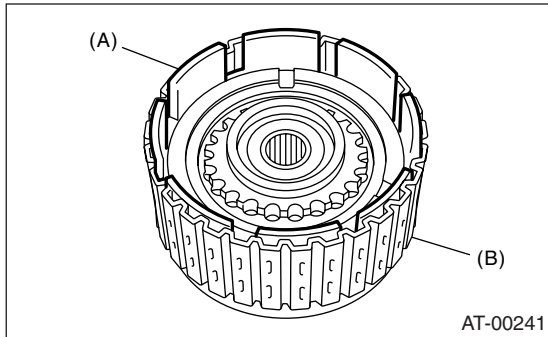

(A) Reverse clutch piston
(B) High clutch drum

4) Install spring retainer to high clutch piston.

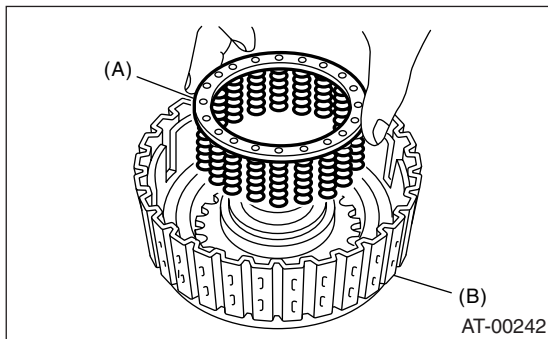

(A) Return spring
(B) High clutch drum

5) Install ST to high clutch piston.

ST 498437000 HIGH CLUTCH PISTON GUIDE

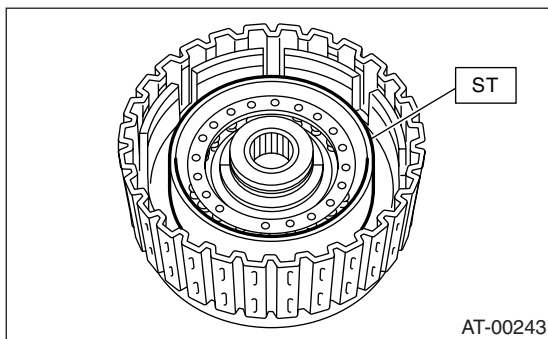

6) Avoid folding the high clutch piston seal, when installing the cover to high clutch piston.

7) Install the snap ring using ST 1, 2, and 3.

ST1 398673600 COMPRESSOR
ST2 498627100 SEAT
ST3 498437000 HIGH CLUTCH PISTON GUIDE

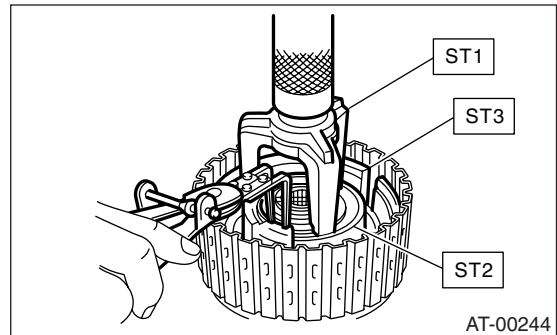

8) Install the thickest driven plate to piston side, and then install the driven plate, drive plate, retaining plate to high clutch drum.

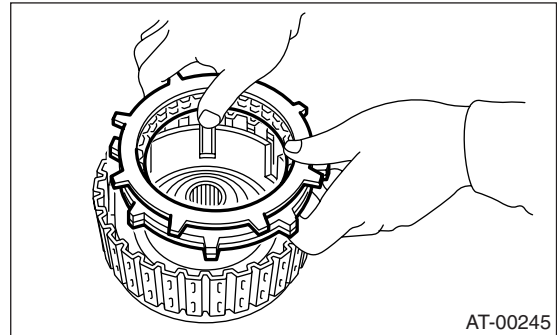

9) Install the snap ring to high clutch drum.

10) Apply compressed air intermittently to check for operation.

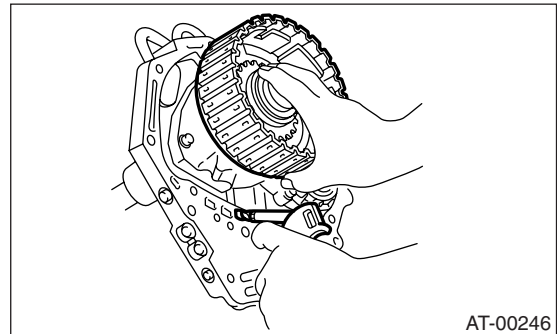

11) Selection of high clutch retaining plate (Non-turbo model)

(1) Place the dish plate, driven plate, drive plate and retaining plate neatly in this order on surface table.

(2) Set the dial gauge to clutch, and read its scale.

NOTE:

The value, which is read in the gauge at this time, is zero point.

(3) Scale and record the weight Z of a flat board which will be put on plates.

NOTE:

- Use a stiff flat board which does not bend against load.
- Use a flat board of its weight less than 25.5 kg (56.2 lb).

(4) Put the flat board on retaining plate.

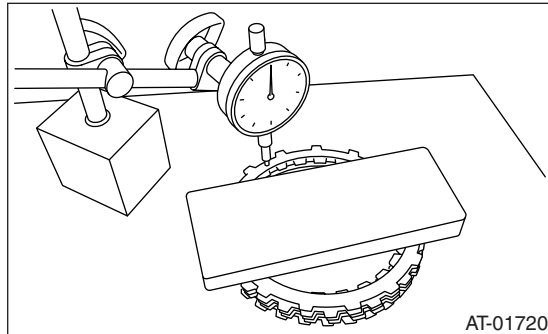

(5) Using the following formula, calculate N indicated on the push/pull gauge.

$$N = 250 \text{ N (25.5 kgf, 56.2 lbf)} - Z$$

N: Value indicated on push/pull gauge

250 N (25.5 kgf, 56.2 lbf): Load applied to clutch plate

Z: Flat board weight

(6) Press the center of retaining plate applying force of N with push/pull gauge, and then measure and record the height "A". Make more than three measurements at even distance and take the average value.

NOTE:

If three points, measure the height every 120°. If four points, measure the height every 90°.

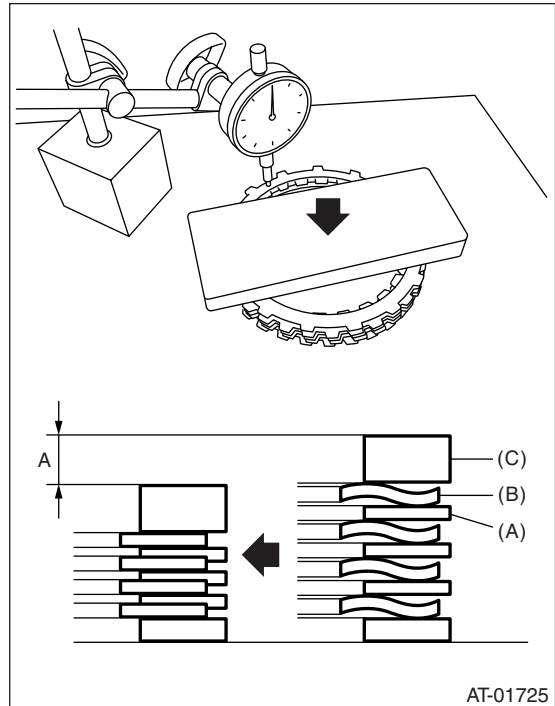

- (A) Driven plate
- (B) Drive plate
- (C) Retaining plate

12) Measure the clearance between the retaining plate of high clutch and snap ring. (Turbo model)
At this time, do not press down the retaining plate.

Initial standard:

0.8 — 1.1 mm (0.031 — 0.043 in)

Limit thickness:

1.5 mm (0.059 in)

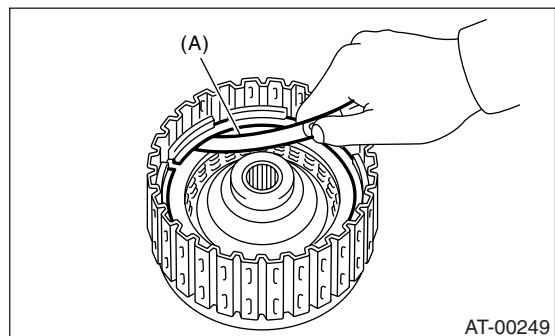

- (A) Thickness gauge

If it exceeds the service limit, replace the drive plate with a new one and adjust it within the specification.

AT Main Case

AUTOMATIC TRANSMISSION

High clutch retaining plate	
Part number	Thickness mm (in)
31567AA710	4.7 (0.185)
31567AA720	4.8 (0.189)
31567AA730	4.9 (0.193)
31567AA740	5.0 (0.197)
31567AA670	5.1 (0.201)
31567AA680	5.2 (0.205)
31567AA690	5.3 (0.209)
31567AA700	5.4 (0.213)

NOTE:

Do not make adjustment unless the drive plate is replaced.

13) Check the piston stroke. (Non-turbo model)

- Measure and record the clearance "B" between the retaining plate and snap ring. (High clutch)

At this time, do not press down the retaining plate.

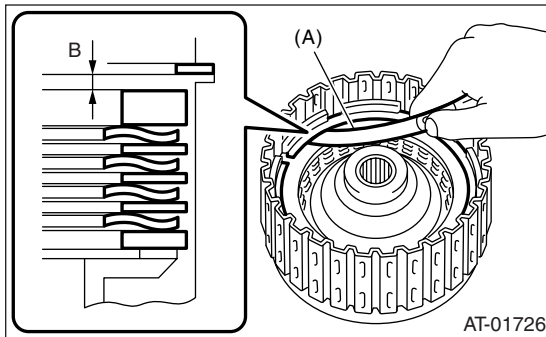

(A) Thickness gauge

(2) Piston stroke calculation

Calculate with "A" and "B" dimensions which have been recorded before, and if the value exceeds the service limit, replace the drive plate with a new one and adjust it within the specification.

$$T = A + B$$

T: Piston stroke

A: Collapse amount of drive plate

B: Clearance between retaining plate and snap ring

Initial standard:

2.0 — 2.3 mm (0.079 — 0.091 in)

Limit thickness:

2.6 mm (0.102 in)

High clutch retaining plate	
Part number	Thickness mm (in)
31567AA670	5.1 (0.201)
31567AA680	5.2 (0.205)
31567AA690	5.3 (0.209)
31567AA700	5.4 (0.213)
31567AA710	4.7 (0.185)
31567AA720	4.8 (0.189)
31567AA730	4.9 (0.193)
31567AA740	5.0 (0.197)

14) Selection of reverse clutch retaining plate

- Place the dish plate, driven plate, drive plate and retaining plate neatly in this order on surface table.

- Set the dial gauge to clutch, and read its scale.

NOTE:

The value, which is read in the gauge at this time, is zero point.

- Scale and record the weight Z of a flat board which will be put on plates.

NOTE:

- Use a stiff flat board which does not bend against load.
- Use a flat board of its weight less than 15.3 kg (33.7 lb).

- Put the flat board on retaining plate.

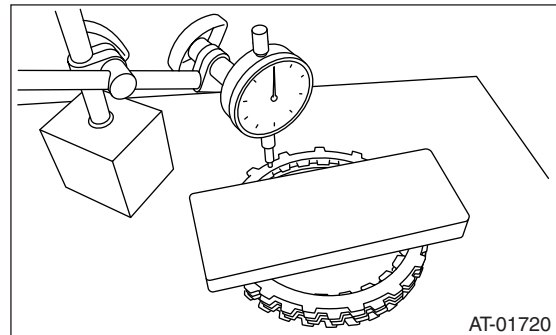

- Using the following formula, calculate N indicated on the push/pull gauge.

$$N = 150 \text{ N (15.3 kgf, 33.7 lbf)} - Z$$

N: Value indicated on push/pull gauge

150 N (15.3 kgf, 33.7 lbf): Load applied to clutch plate

Z: Flat board weight

- Press the center of retaining plate applying force of N with push/pull gauge, and then measure and record the height "A". Make more than three measurements at even distance and take the average value.

NOTE:

If three points, measure the height every 120°. If four points, measure the height every 90°.

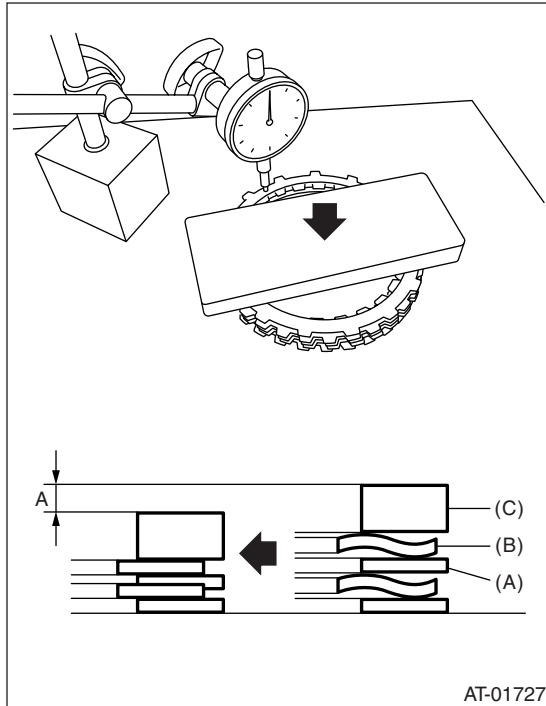

- (A) Driven plate
- (B) Drive plate
- (C) Retaining plate

(7) Install the driven plate, drive plate, retaining plate and snap ring.

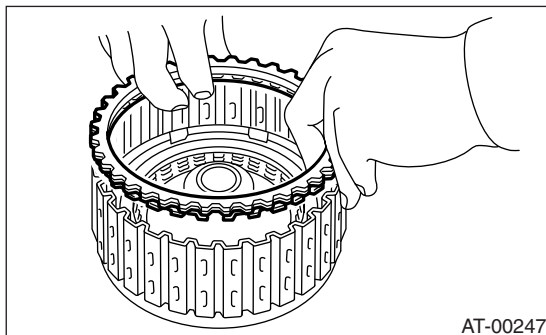

(8) Apply compressed air intermittently to check for operation.

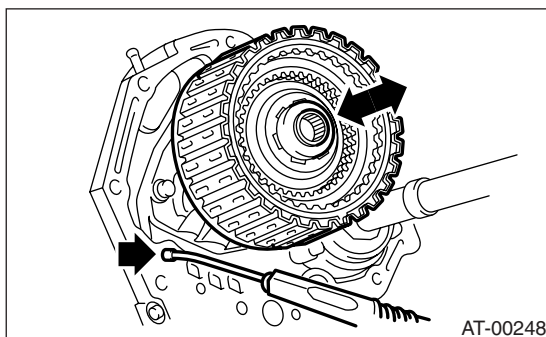

15) Check the piston stroke.

(1) Measure and record the clearance "B" between the retaining plate and snap ring. (Reverse clutch)

At this time, do not press down the retaining plate.

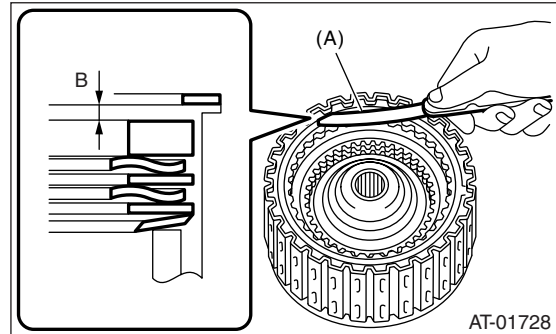

(A) Thickness gauge

(2) Piston stroke calculation

Calculate with "A" and "B" dimensions which have been recorded before, and if the value exceeds the service limit, replace the drive plate with a new one and adjust it within the specification.

$$T = A + B$$

T: Piston stroke

A: Collapse amount of drive plate

B: Clearance between retaining plate and snap ring

Initial standard:

1.1 — 1.4 mm (0.043 — 0.055 in)

Limit thickness:

1.6 mm (0.063 in)

Reverse clutch retaining plate	
Part number	Thickness mm (in)
31567AA910	4.0 (0.157)
31567AA920	4.2 (0.165)
31567AA930	4.4 (0.173)
31567AA940	4.6 (0.181)
31567AA950	4.8 (0.189)
31567AA960	5.0 (0.197)
31567AA970	5.2 (0.205)
31567AA980	5.4 (0.213)

NOTE:

Do not make adjustment unless the drive plate is replaced.

AT Main Case

AUTOMATIC TRANSMISSION

2. PLANETARY GEAR, LOW CLUTCH

- 1) Install D-ring to low clutch piston.
- 2) Fit the low clutch piston to the low clutch drum.

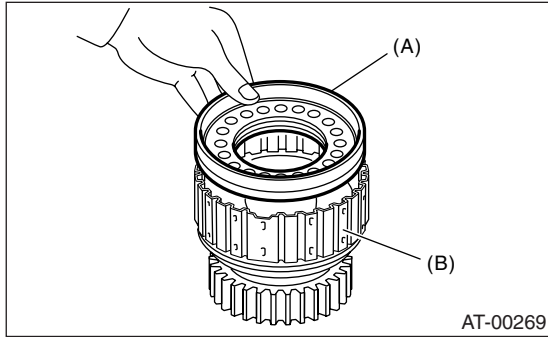

- (A) Low clutch piston
- (B) Low clutch drum

- 3) Install spring retainer to low clutch piston.

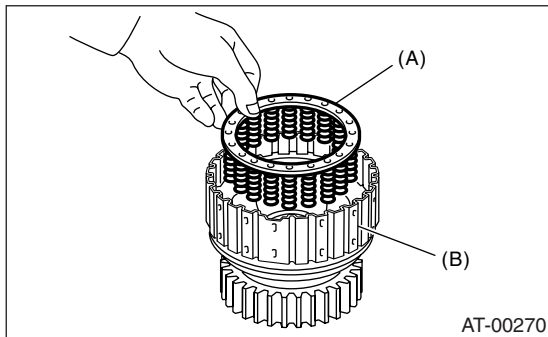

- (A) Spring retainer
- (B) Low clutch drum

- 4) Install ST to low clutch drum.

ST 498437100 LOW CLUTCH PISTON GUIDE

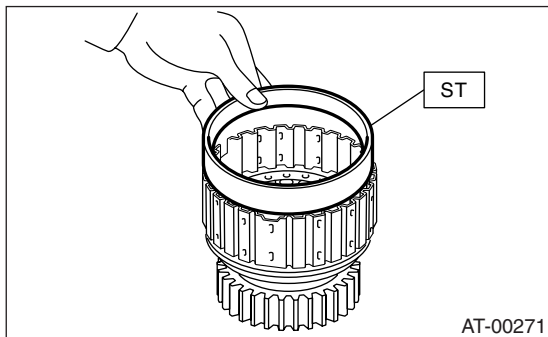

- 5) Set the cover on the piston with a press using ST1 and ST2, and attach the snap ring. At this time, be careful not to fold cover seal during installation.

ST1 498627100 SEAT
ST2 398673600 COMPRESSOR

ST3 498437100 LOW CLUTCH PISTON GUIDE

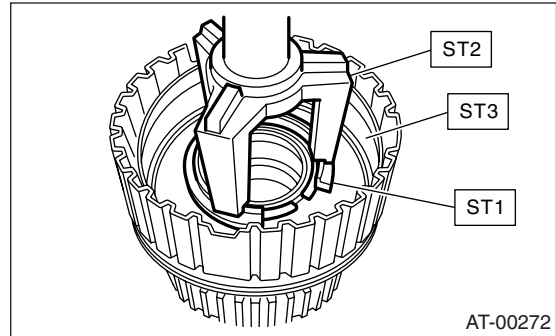

- 6) Install the dish plate, driven plates, drive plates, and retaining plate, and secure with the snap ring.

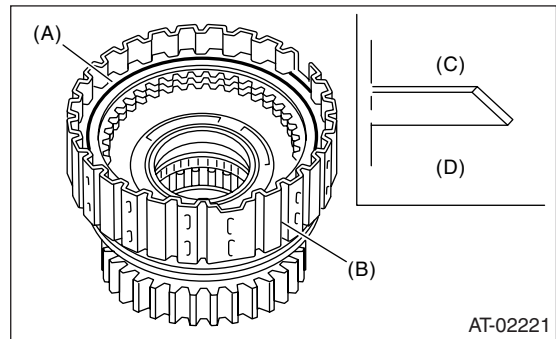

- (A) Snap ring
- (B) Low clutch drum
- (C) Dish plate
- (D) Low clutch piston side

- 7) Check the low clutch for operation.

(1) Remove one-way clutch. <Ref. to 4AT-105, REMOVAL, AT Main Case.>

(2) Set the one-way clutch inner race, and apply compressed air for checking.

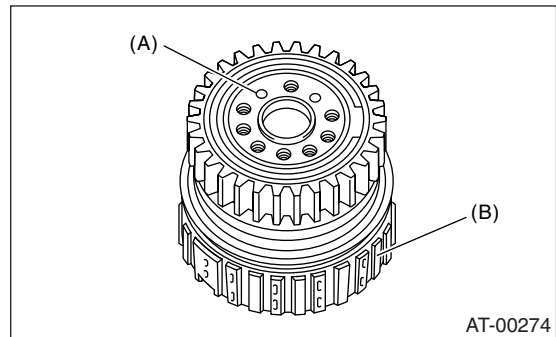

- (A) Apply compressed air.
- (B) Low clutch drum

- 8) Checking low clutch clearance.

(1) Place the same thickness of shim on both sides to prevent retaining plate from tilting.

(2) Inspect clearance between retaining plate and operation of the low clutch.

Initial standard:

0.7 — 1.1 mm (0.028 — 0.043 in)

Limit thickness:

1.6 mm (0.063 in)

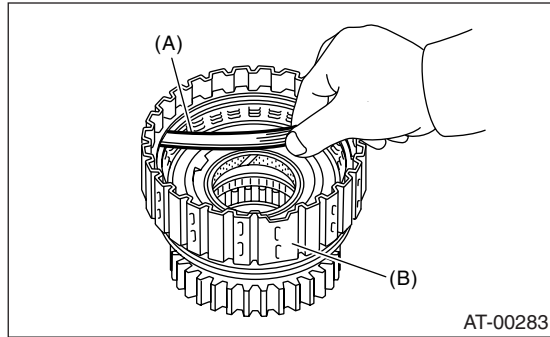

- (A) Thickness gauge
- (B) Low clutch drum

Do not make adjustment unless the drive plate is replaced.
If it exceeds the service limit, replace the drive plate with a new one and adjust it to the specification.

Available retaining plate	
Part No.	Thickness mm (in)
31567AA830	3.8 (0.150)
31567AA840	4.0 (0.157)
31567AA850	4.2 (0.165)
31567AA860	4.4 (0.173)
31567AA870	4.6 (0.181)

9) Install washer to rear internal gear.

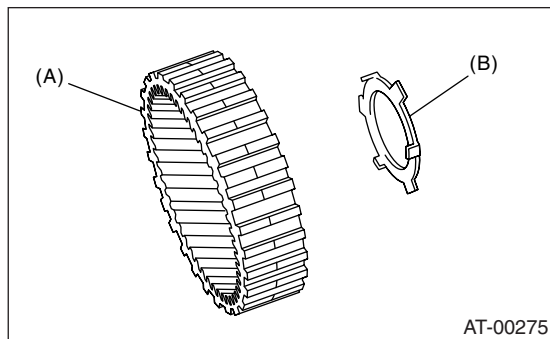

- (A) Rear internal gear
- (B) Washer

10) Install rear internal gear.

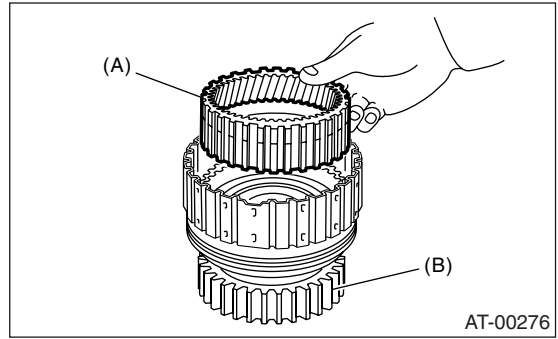

- (A) Rear internal gear
- (B) Low clutch drum

11) Install thrust needle bearing in the correct direction.

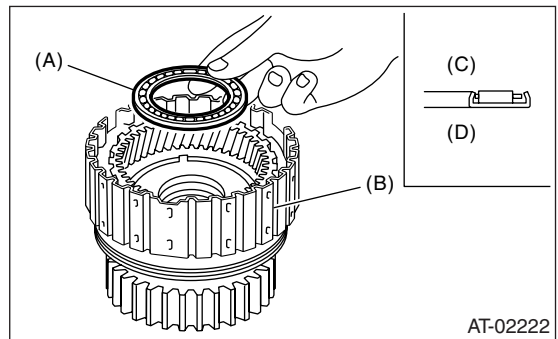

- (A) Thrust needle bearing
- (B) Low clutch drum
- (C) Rear planetary carrier side
- (D) Low clutch drum side

12) Install the washer by aligning protrusion of washer and hole of rear planetary carrier.

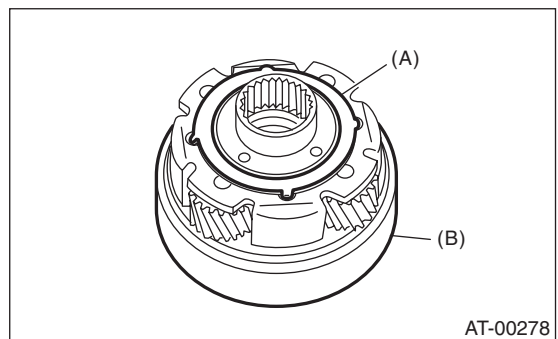

- (A) Washer
- (B) Rear planetary carrier

AT Main Case

AUTOMATIC TRANSMISSION

13) Install rear planetary carrier to low clutch drum.

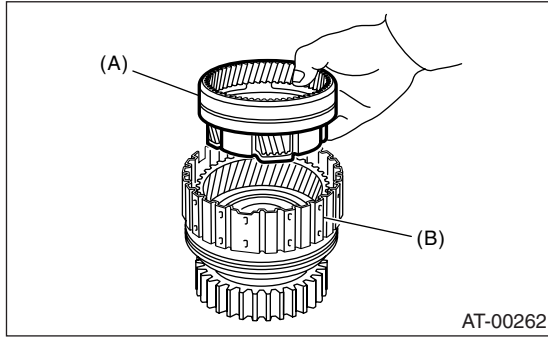

(A) Rear planetary carrier

(B) Low clutch drum

14) Install thrust needle bearing in the correct direction.

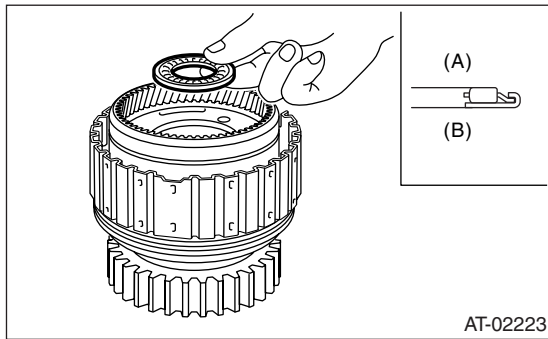

(A) Rear sun gear side

(B) Low clutch drum side

15) Install the rear sun gear in proper direction.

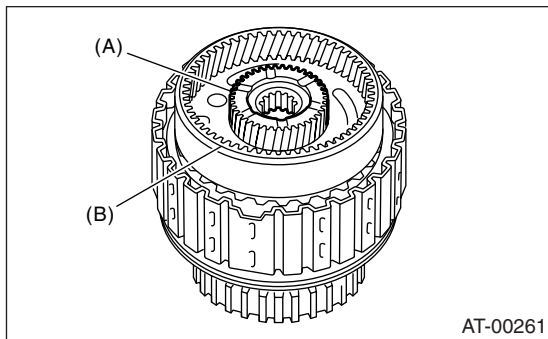

(A) Rear sun gear

(B) Rear planetary carrier

16) Install the thrust needle bearing in proper direction.

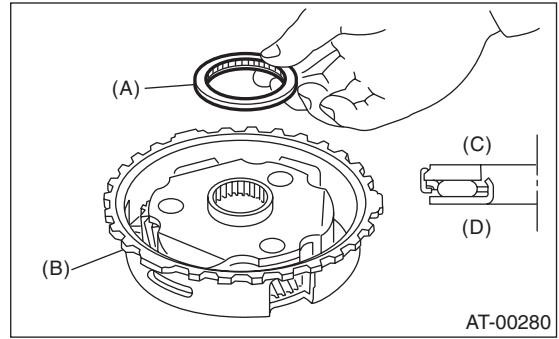

(A) Thrust needle bearing

(B) Front planetary carrier

(C) Rear sun gear side

(D) Front planetary carrier side

17) Install front planetary carrier to low clutch drum.

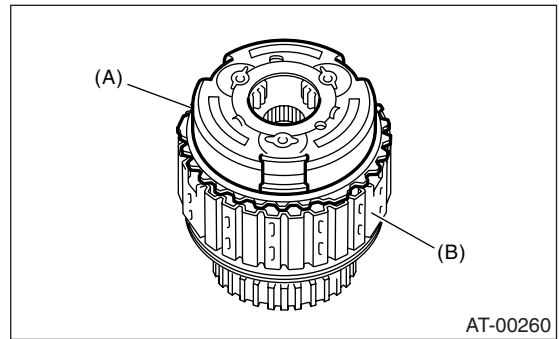

(A) Front planetary carrier

(B) Low clutch drum

18) Install snap ring to low clutch drum.

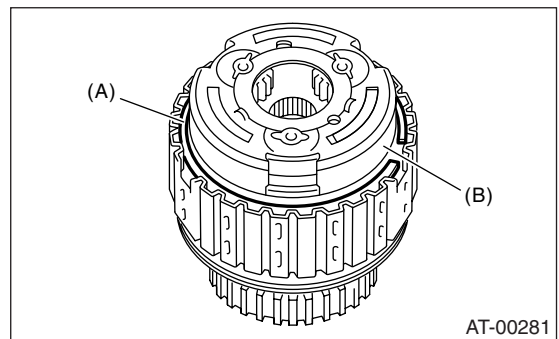

(A) Snap ring

(B) Front planetary carrier

19) Install the needle bearing, and secure with the snap ring.

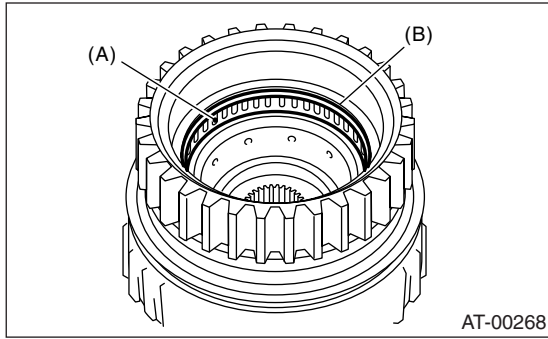

- (A) Needle bearing
- (B) Snap ring

20) Install the one-way clutch, and secure with the snap ring.

21) Set the inner race. Make sure that the clutch is locked in the clockwise direction and rotates in the counterclockwise direction.

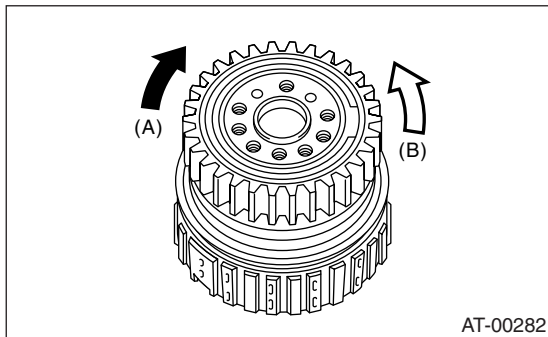

- (A) Locked
- (B) Rotates

3. 2-4 BRAKE

1) Apply ATF to new D-ring, and install it to 2-4 brake piston.

2) Install 2-4 brake piston to 2-4 brake piston retainer.

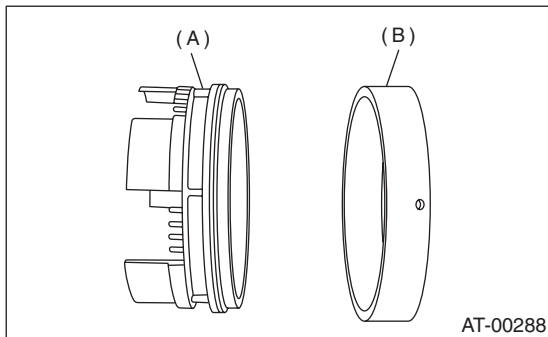

- (A) 2-4 brake piston
- (B) 2-4 brake piston retainer

4. ONE-WAY CLUTCH INNER RACE

1) Using a press and ST, install the needle bearing to the inner race.

ST 398497701 INSTALLER

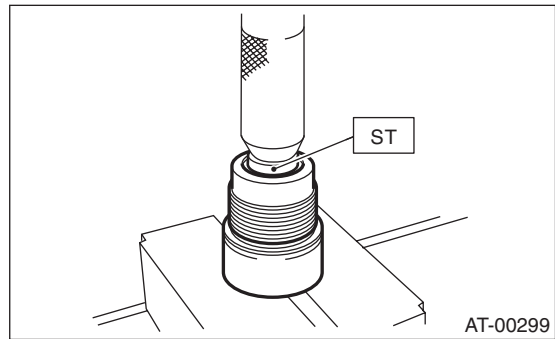

2) Apply vaseline to the groove of the inner race and to the seal ring.

3) Install two seal rings to one-way clutch inner race.

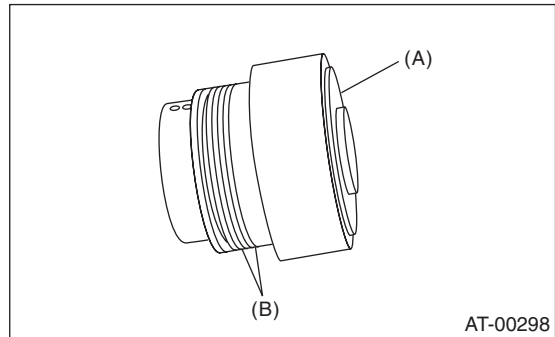

- (A) One way clutch inner race
- (B) Seal rings

5. ONE-WAY CLUTCH OUTER RACE

1) Install the needle bearing, and secure with the snap ring.

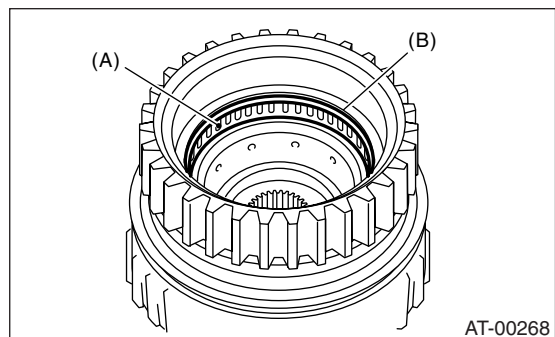

- (A) Needle bearing
- (B) Snap ring

2) Install the one-way clutch, one-way clutch inner race and plate, and secure with the snap ring.

3) Set the inner race. Make sure that the clutch is locked in the clockwise direction and rotates in the counterclockwise direction.

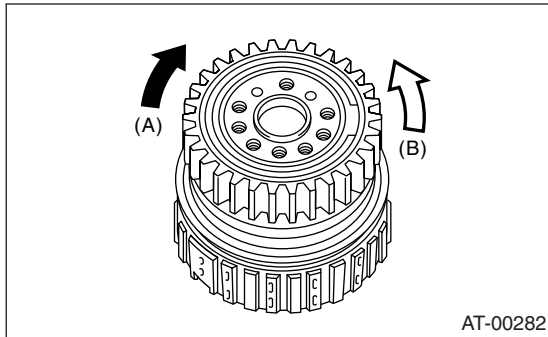

- (A) Locked
- (B) Rotates

E: INSPECTION

1. HIGH CLUTCH AND REVERSE CLUTCH

Inspect the following items:

- Drive plate facing for wear and damage
- Discoloration of driven plate (Burnt color)
- Snap ring for wear, return spring for setting and breakage, and snap ring retainer for deformation
- Lip seal and D-ring for damage
- Piston and drum check ball for operation
- Adjust total end play. <Ref. to 4AT-93, ADJUSTMENT, Oil Pump Housing.>

2. PLANETARY GEAR AND LOW CLUTCH

Inspect the following items:

- Drive plate facing for wear and damage
- Discoloration of driven plate (Burnt color)
- Snap ring for wear, return spring for breakage or setting, and spring retainer for deformation
- Lip seal and D-ring for damage
- Piston check ball for operation
- Measure the total end play and adjust to within specifications. <Ref. to 4AT-93, ADJUSTMENT, Oil Pump Housing.>

3. 2-4 BRAKE

Inspect the following items:

- Drive plate facing for wear and damage
- Discoloration of driven plate (Burnt color)
- Snap ring for wear and spring retainer for deformation
- Lip seal and D-ring for damage
- Measure the total end play and adjust to within specifications. <Ref. to 4AT-93, ADJUSTMENT, Oil Pump Housing.>

4. ONE-WAY CLUTCH

- Make sure the snap ring is not worn and the seal rings are not damaged.
- Measure the total end play and adjust to within specifications. <Ref. to 4AT-93, ADJUSTMENT, Oil Pump Housing.>

5. LOW & REVERSE BRAKE

Check for the following:

- Drive plate facing for wear or damage
- Discoloration of driven plate (Burnt color)
- Snap ring for wear and spring retainer for deformation

38. Transmission Control Device

A: REMOVAL

- 1) Remove the transmission assembly from the vehicle. <Ref. to 4AT-38, REMOVAL, Automatic Transmission Assembly.>
- 2) Extract the torque converter clutch assembly. <Ref. to 4AT-67, REMOVAL, Torque Converter Clutch Assembly.>
- 3) Remove the input shaft.
- 4) Lift-up lever behind the transmission harness connector and disconnect it from stay.
- 5) Disconnect the air breather hoses. <Ref. to 4AT-65, REMOVAL, Air Breather Hose.>
- 6) Disconnect inhibitor switch connector from stay.
- 7) Wrap vinyl tape around the nipple attached to the air breather hose.
- 8) Remove pitching stopper bracket.
- 9) Remove the inhibitor switch.

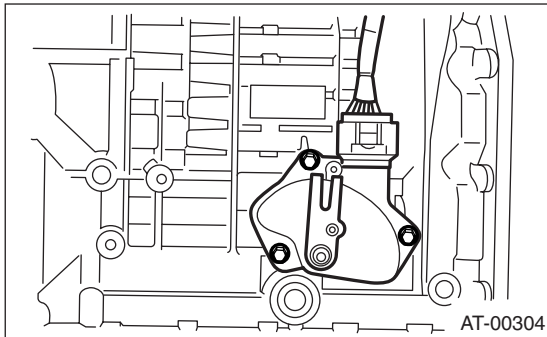

- 10) Remove control valve body assembly. <Ref. to 4AT-57, REMOVAL, Control Valve Body.>
- 11) Pull off the straight pin of manual plate.

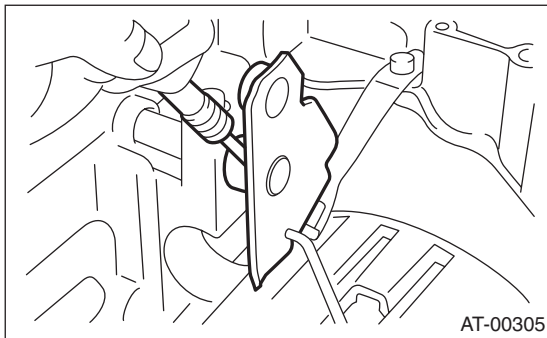

- 12) Remove bolt securing select lever, then remove select lever, manual plate and parking rod.

NOTE:

Be careful not to damage the lips of the press-fitted oil seal in the case.

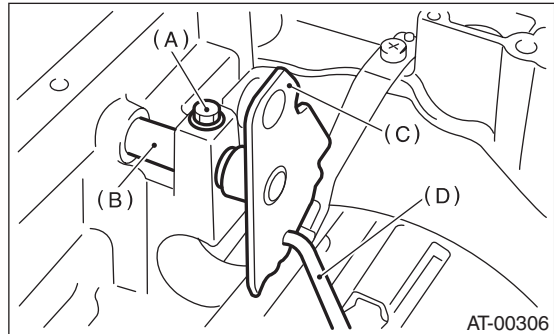

- (A) Bolt
- (B) Range select lever
- (C) Manual plate
- (D) Parking rod

- 13) Remove the detent spring.

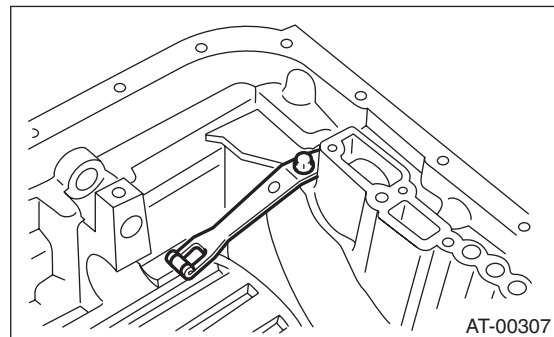

B: INSTALLATION

- 1) Install detent spring to transmission case.

Tightening torque:

6 N·m (0.6 kgf-m, 4.3 ft-lb)

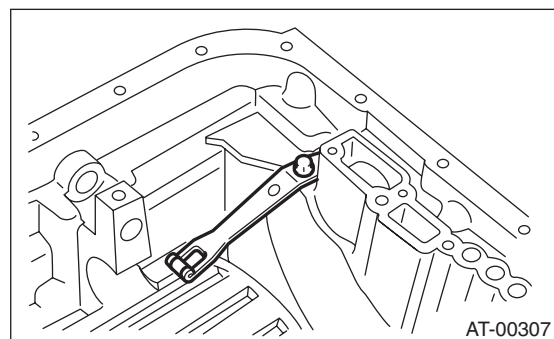

- 2) Insert range select lever, and tighten bolt.

Transmission Control Device

AUTOMATIC TRANSMISSION

Tightening torque:

6 N·m (0.6 kgf-m, 4.3 ft-lb)

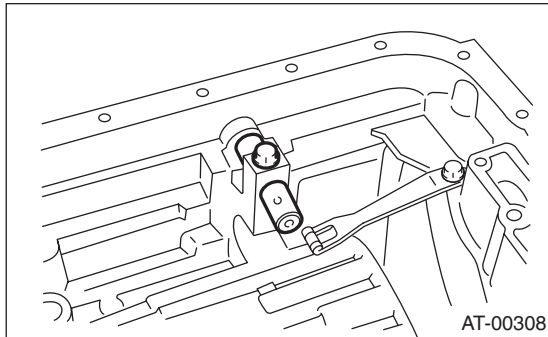

3) Install the manual plate and parking rod.

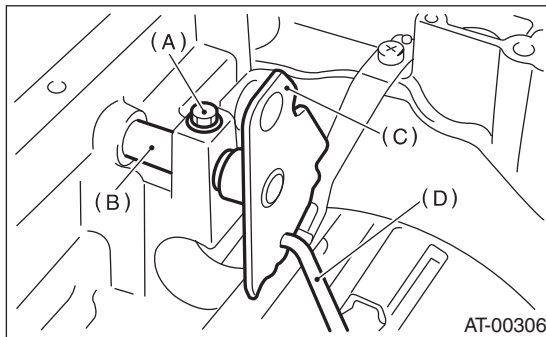

- (A) Bolt
- (B) Range select lever
- (C) Manual plate
- (D) Parking rod

4) Insert spring pin to manual plate.

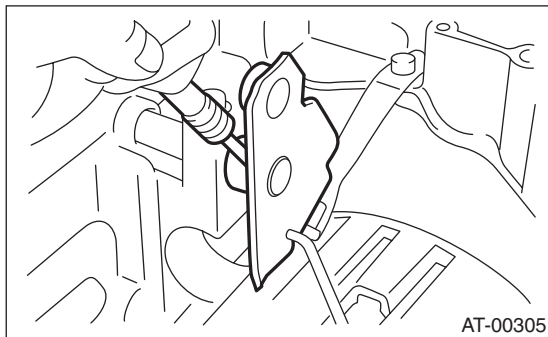

5) Install control valve assembly and oil pan. <Ref. to 4AT-57, INSTALLATION, Control Valve Body.>

6) Turn over the transmission case to its original position.

7) Install pitching stopper bracket.

Tightening torque:

41 N·m (4.2 kgf-m, 30.2 ft-lb)

8) Install inhibitor switch and adjust the inhibitor switch. <Ref. to 4AT-48, Inhibitor Switch.>

9) Insert inhibitor switch and transmission connector into stay.

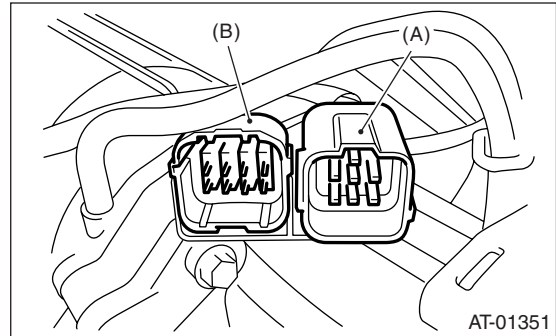

- (A) Transmission harness
- (B) Inhibitor switch harness

10) Install air breather hose. <Ref. to 4AT-65, INSTALLATION, Air Breather Hose.>

11) Insert the input shaft while rotating it lightly by hand, and then check the protrusion amount.

Normal protrusion amount A:

50 — 55 mm (1.97 — 2.17 in)

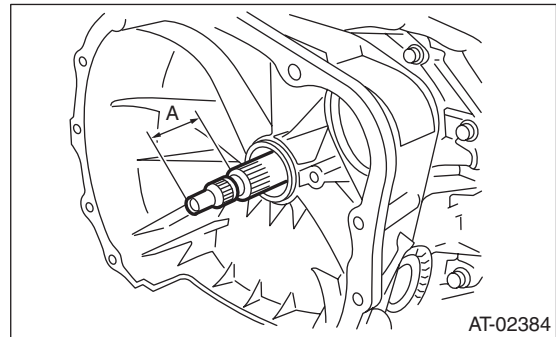

12) Install the torque converter clutch assembly. <Ref. to 4AT-67, INSTALLATION, Torque Converter Clutch Assembly.>

13) Install the transmission assembly to the vehicle. <Ref. to 4AT-40, INSTALLATION, Automatic Transmission Assembly.>

C: INSPECTION

Make sure the manual lever and detent spring are not worn or otherwise damaged.